



KRAUS-ANDERSON®
Construction Company

Change Order Request

Project: 1923025-02
La Crosse Center Expansion & Renovation
400 La Crosse Street
La Crosse, WI 54601

COR # 123.00

Date: 12/9/2020

To: Owner City of La Crosse
400 La Crosse Street
La Crosse, WI 54601

From: Kraus-Anderson Construction Company
151 East Wilson Street, Suite 100
Madison, WI 53703

PCO # 207 - RFI 351

Item #	Description	Vendor	Amount
1	RFI 351	North American Mechanical, Inc.	\$7,343.00
Total For Change Order			\$7,343.00

Approved By: City of La Crosse

Signed: _____

Date: _____

Submitted By: Kraus-Anderson Construction Company

Signed: *Peter Linsmeier*
6867371012384A6...
DocuSigned by:

Date: 1/4/2021 | 1:36 PM CST

Accepted By: I & S Group, Inc.

Signed: *Kevin Bills*
B2D92ADEC16949C...

Date: 1/7/2021 | 7:51 AM CST

Proposal Request / Construction Bulletin Quote



North American Mechanical, Inc.
4401 State Road 19
Windsor, WI 53598

Phone: (608) 842-3900

PR/ CB # **RFI #351**

Date: **12/1/20**

Project Name: Lacrosse Center

Project #: 6200002

To: Kraus Anderson Attn: Peter Linsmeier Phone: 608-630-4870 From: Dan Davis	Notes:
---	---------------

Below is a Breakdown of NAMI's Cost for the above referenced PR/CB

Materials	Total
SM Materials	\$673.00
Pipe Materials	
Equipment	
Delivery	
Rented Equipment	
Tools	
Tax	\$37.02
Mark up Material	10.0% \$71.00
Sub Total Materials	\$781.02

Labor	Hrs	Rate	Total
Project Manager		\$105.00	\$0.00
SM Shop Labor	23	\$85.00	\$1,955.00
Pipe Shop Labor		\$85.00	\$0.00
Site Superintendent	2	\$95.00	\$190.00
Field SM	32	\$85.00	\$2,720.00
Field Pipe		\$85.00	\$0.00
0		\$0.00	\$0.00
0		\$0.00	\$0.00
Mark up Labor		10.0%	\$486.50
Labor Subtotal	57		\$5,351.50

Subcontractors	Total
Insulation	\$1,100.00
0	
0	
0	
0	
0	
Mark up Subcontractors	10.0% \$110.00
Subcontractor Subtotal	\$1,210.00
Bond	0.00% \$0.00
Warranty	0.00% \$0.00

Total **\$7,343**

Please let me know if you have any questions.

Thanks,
Dan Davis
Project Manager
North American Mechanical Inc.
(608) 842-3900

North American Mechanical Inc. 

6135 North American Lane, Deforest, WI 53532

A Comfort System USA, Inc. Company**Time and Material Ticket**

Project Name: LAX Center
 Requested by: _____
 Address: _____

Project Number: 6200002
 Date: 12-21-2020
 Foreman: Keith Mickelson

Description of Work: Added sheet metal fittings needed to
install New Diffusers Arena level North Corridor
A 101 with manual Balance Dampers.

Time

Date	Employee Name	Hours
12-16-20	Wyatt Mickelson	10 hrs
12-16-20	Eric Godfrey	10 hrs
12-17-20	Wyatt Mickelson	8 hrs
12-17-20	Eric Godfrey	8 hrs
12-15-20	Sheet metal FAB	23 hrs
Total		59 HRS

Material

Quantity	Description
1673.00	Sketch 36270, 36271 & 36272

Approved and Correct

Customer Representative

NORTH AMERICAN MECHANICAL

Job Name: LAX Center

Job Number: 6200002

Date Drawn: 12-2

Needed By: 12-15-20

Equip. Descript: 3m2-10A

W.G. in Inches: +2

SKETCH NO. 36270

Takeoff # (Shop Use): _____

Drawn By: Keith M

Liner: NO

Shop Install External Wrap: NO

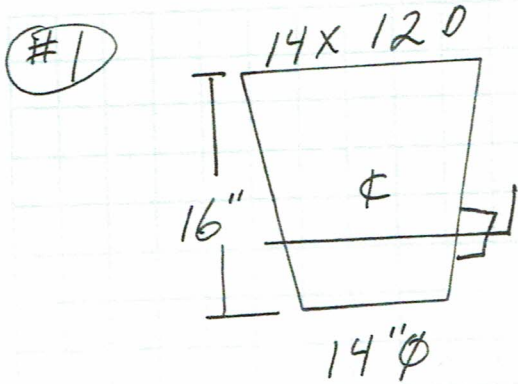

#2

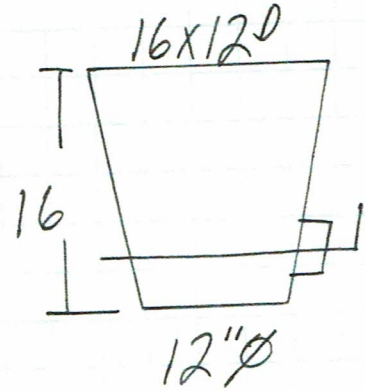

#4

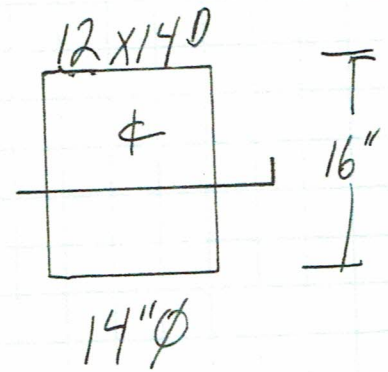
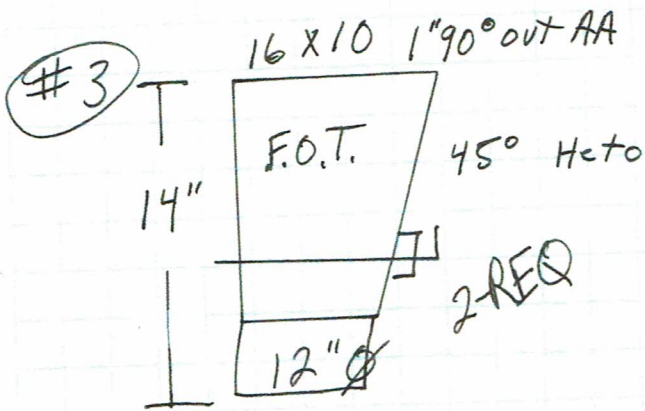

#5

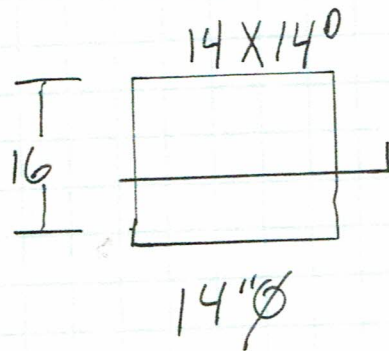

#10

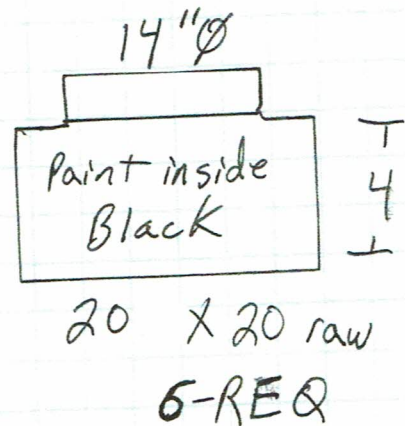

#18

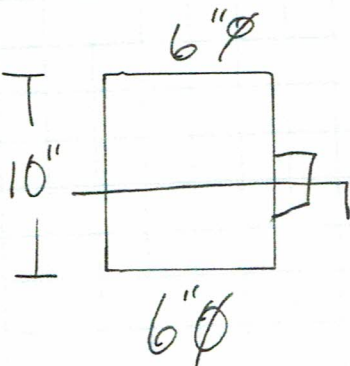

#19

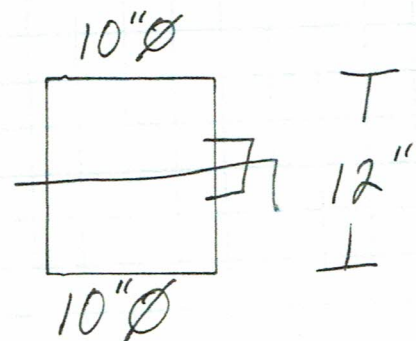

NORTH AMERICAN MECHANICAL

Job Name: LAX Center

Job Number: 6200002

Date Drawn: R2

Needed By: 12-15-20

Equip. Descript: 3M 2-10B

W.G. in Inches: T2

SKETCH NO. 36271

Takeoff # (Shop Use): _____

Drawn By: Keith M

Liner: NO

Shop Install External Wrap: NO

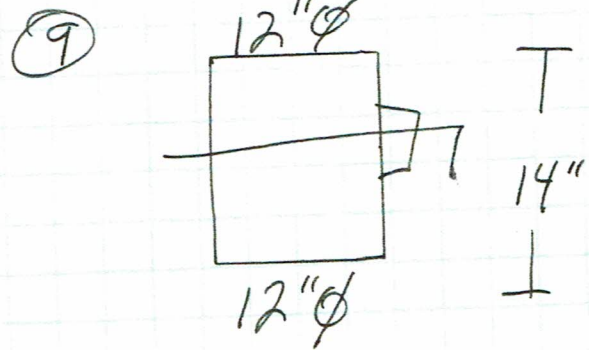
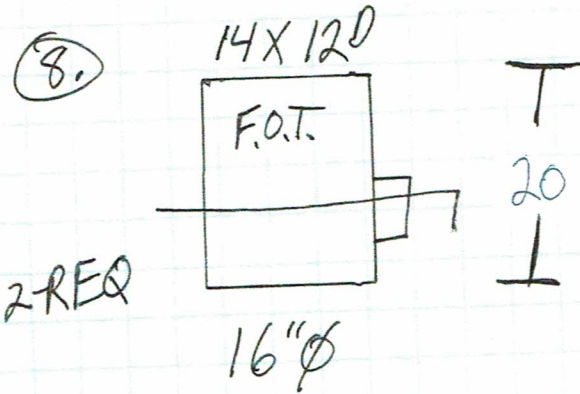
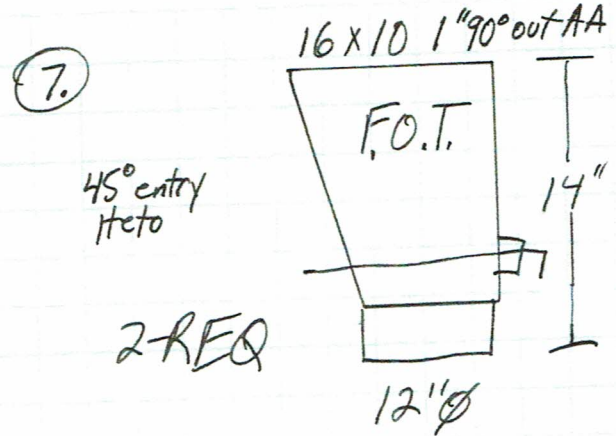
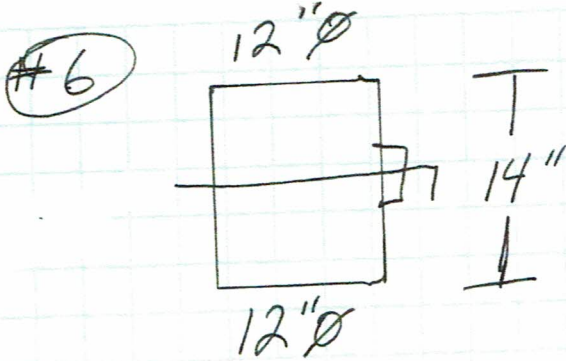

#11 14" A collar
2-REQ

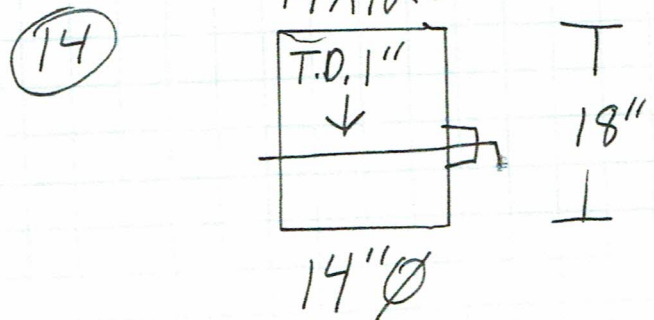
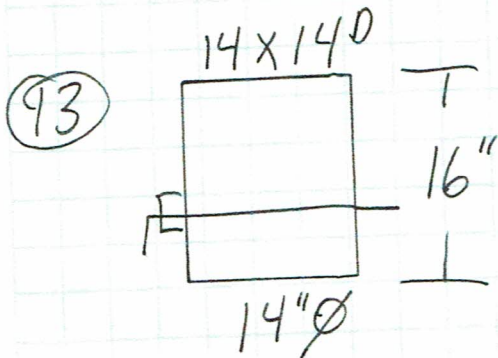
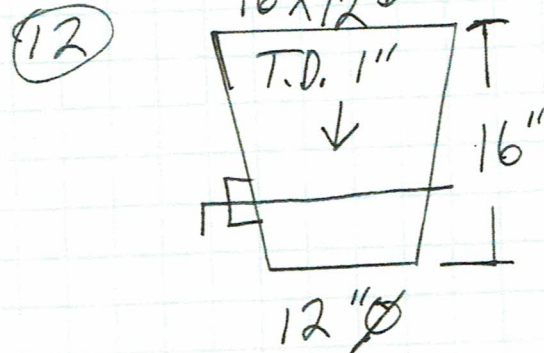

NORTH AMERICAN MECHANICAL

Job Name: LAX Center

Job Number: 6200002

Date Drawn: 12-2

Needed By: 12-15-20

Equip. Descript: 3 1/2-10B

W.G. in Inches: +2

SKETCH NO. 36272

Takeoff # (Shop Use): _____

Drawn By: Keith M

Liner: NO

Shop Install External Wrap: NO

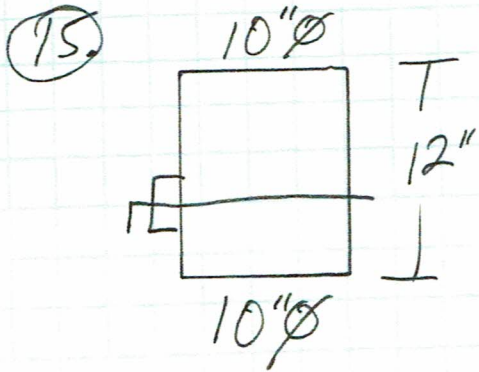

(16) 6" ϕ Damper With raised Platform handle

