



TASK NAME: 07758.MX

TASK DESCRIPTION: 1300 PINE ST

SITE LOCATION: LACROSSE, WI, USA



3701 COMMUNICATIONS WAY  
EVANSVILLE, IN, 47715



1100 E. WOODFIELD ROAD, SUITE 500  
SCHAUMBURG, ILLINOIS 60173  
TEL: 847-908-8400  
DESIGN FIRM NO. 184.008202-0006  
www.fullerton-us.com

**PROJECT INFORMATION**

TASK NAME: 07758.MX  
 TASK DESCRIPTION: 1300 PINE ST  
 SITE LOCATION: LaCrosse, WI, USA  
 SITE TYPE: UNDERGROUND FIBER-OPTIC CONSTRUCTION  
 JURISDICTION: LaCrosse, WI, USA  
 APN: -  
 ZONING CLASSIFICATION: -  
 OCCUPANCY TYPE: -  
 CONSTRUCTION TYPE: -  
 APPLICANT: METRO FIBERNET, LLC  
 ADDRESS: 3701 COMMUNICATIONS WAY  
EVANSVILLE, IN, 47715  
 CONTACT: AMY VAN RENS  
 PHONE: (608) 217-8566  
 EMAIL: AMY.VAN-RENS@METRONET.COM

NOTE: DRAWING SCALES ARE FOR 11"x17" SHEETS UNLESS OTHERWISE NOTED

**PROJECT CONSULTANTS**

PROJECT MANAGER: FULLERTON ENGINEERING CONSULTANTS, LLC  
 ADDRESS: 1100 E. WOODFIELD ROAD, SUITE 500  
 CONTACT: MICHELLE KAMINSKI  
 PHONE: (616) 262-5967  
 EMAIL: MKAMINSKI@FULLERTONENGINEERING.COM  
 ENGINEER: FULLERTON ENGINEERING CONSULTANTS, LLC  
 ADDRESS: 1100 E. WOODFIELD ROAD, SUITE 500  
 SCHAUMBURG, ILLINOIS 60173  
 EOR: DAN SMITH, P.E.  
 PHONE: 847-908-8521  
 EMAIL: DSMITH@FULLERTONENGINEERING.COM  
 POWER COMPANY:  
 PHONE:  
 TELEPHONE COMPANY:  
 PHONE:

**BILL OF MATERIALS**

THE SCOPE OF WORK CONSISTS OF:

• ALL MATERIAL SHALL BE INSTALLED BY THE CONTRACTOR, UNLESS STATED OTHERWISE.

**SITE LOCATION MAP**

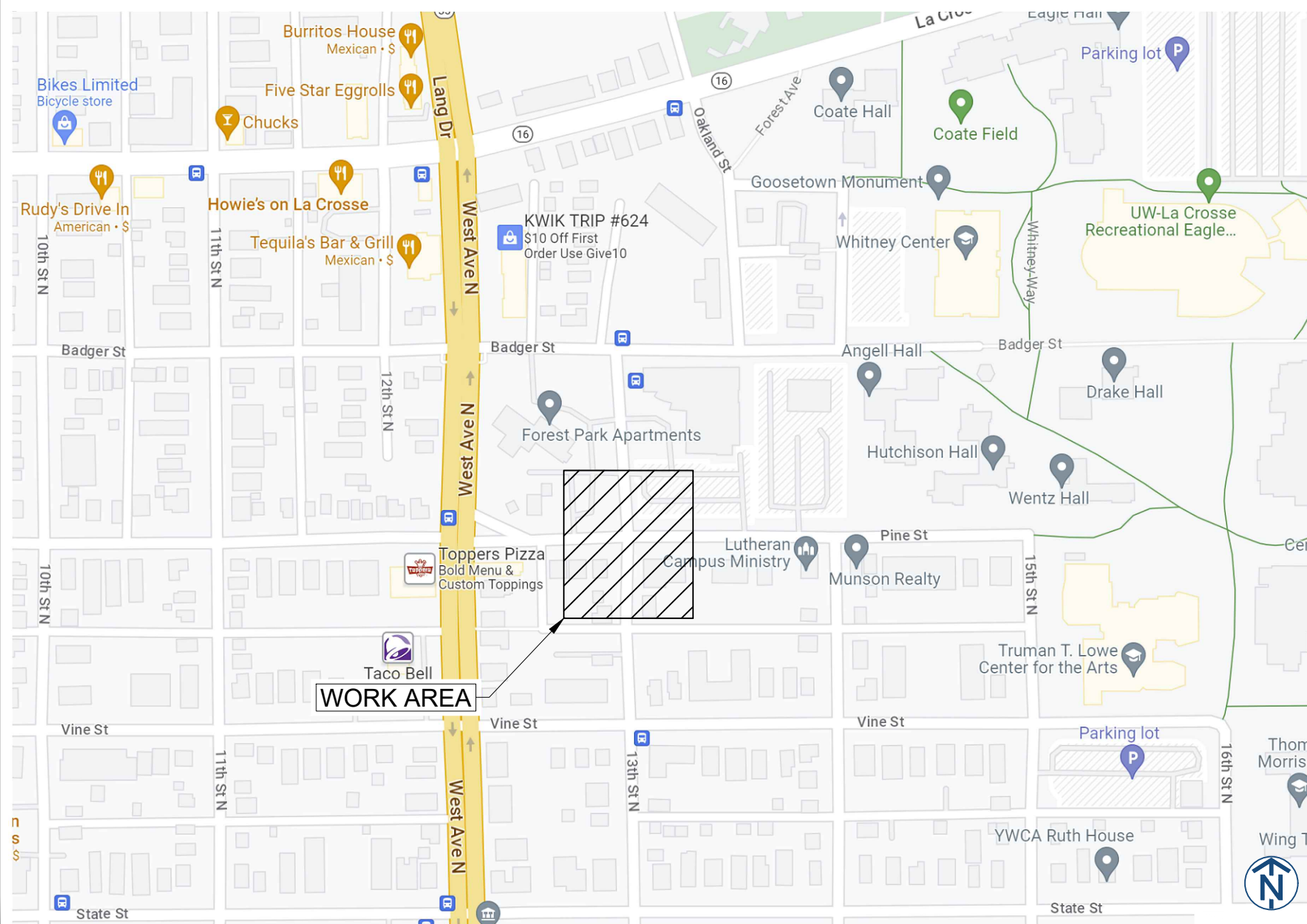

REV	DATE	DESCRIPTION	BY
A	??/??/??	90% REVIEW	??

I HEREBY CERTIFY THAT THESE DRAWINGS WERE PREPARED BY ME OR UNDER MY DIRECT SUPERVISION AND CONTROL, AND TO THE BEST OF MY KNOWLEDGE AND BELIEF COMPLY WITH THE REQUIREMENTS OF ALL APPLICABLE CODES.

TASK NAME  
**07758.MX**

TASK DESCRIPTION  
**1300 PINE ST**

PROJECT AREA  
**LaCrosse, WI, USA**

SHEET SCALE  
**N.T.S.**

SHEET TITLE  
**TITLE SHEET**

GRID NUMBER

SHEET NUMBER  
**T-1**

SHEET NUMBER	SHEET TITLE
T-1	TITLE SHEET
T-2	SHEET INDEX
T-3	LEGEND
GN-1	GENERAL NOTES
MAP-1	MAP
C-01	DESIGN LAYOUT
D-1	DETAILS
D-2	DETAILS
D-3	DETAILS
D-4	DETAILS
D-5	DETAILS
D-6	DETAILS

SHEET NUMBER	SHEET TITLE

SHEET NUMBER	SHEET TITLE

**metronet™**  
3701 COMMUNICATIONS WAY  
EVANSVILLE, IN, 47715

**Fullerton**  
DESIGN DEVELOP CONSTRUCT  
1100 E. WOODFIELD ROAD, SUITE 500  
SCHAUMBURG, ILLINOIS 60173  
TEL: 847-908-8400  
DESIGN FIRM NO. 184.008202-0006  
www.fullerton-us.com

REV	DATE	DESCRIPTION	BY
A	??/??/??	90% REVIEW	??

I HEREBY CERTIFY THAT THESE DRAWINGS WERE PREPARED BY ME OR UNDER MY DIRECT SUPERVISION AND CONTROL, AND TO THE BEST OF MY KNOWLEDGE AND BELIEF COMPLY WITH THE REQUIREMENTS OF ALL APPLICABLE CODES.

TASK NAME  
  
**07758.MX**

TASK DESCRIPTION  
  
**1300 PINE ST**

PROJECT AREA  
  
**LaCrosse, WI, USA**

SHEET SCALE  
  
**N.T.S.**

SHEET TITLE  
  
**SHEET INDEX**

GRID NUMBER

SHEET NUMBER  
  
**T-2**

# LEGEND

<u>PROPOSED</u>		<u>COMED</u>		<u>CTA</u>		<u>DEO/ELECTRIC</u>		<u>ENWAVE/UNICOM</u>		<u>GAS</u>		<u>MISCELLANEOUS</u>	
	PROPOSED OPEN CUT TRENCH		PROPOSED BORE PIT		EXISTING COMED MANHOLE		EXISTING CTA MANHOLE		EXISTING STREET LIGHT POLE		EXISTING ENWAVE/UNICOM MANHOLE		EXISTING GAS MANHOLE
	PROPOSED DIRECTIONAL BORE		PROPOSED 30" COMMUNICATIONS MH		EXISTING COMED		EXISTING CTA		EXISTING TRAFFIC LIGHT POLE		EXISTING GAS VALVE		EXISTING GAS METER
	PROPOSED 4X4 MANHOLE		PROPOSED HANDHOLE		EXISTING CTA MANHOLE		EXISTING ELECTRIC MANHOLE		EXISTING STREET LIGHT HANDHOLE		EXISTING GAS CAP		EXISTING GAS REDUCER
	EXISTING COMED		EXISTING CTA MANHOLE		EXISTING ELECTRIC HANDHOLE		EXISTING RED LIGHT CAMERA POLE		EXISTING ENWAVE/UNICOM		EXISTING GAS MAIN		EXISTING FENCE
	EXISTING CTA		EXISTING ELECTRIC MANHOLE		EXISTING GAS MAIN		EXISTING RED LIGHT FLASH POLE		EXISTING GAS MAIN (DEAD)		EXISTING GAS CAP		EXISTING CONSTRUCTION FENCE
	POTENTIAL BURIED CTA ABANDONED TRACKS		EXISTING ELECTRIC HANDHOLE		EXISTING GAS CAP		EXISTING RED LIGHT CAMERA POLE		EXISTING GAS REDUCER		EXISTING FENCE		EXISTING GUARDRAIL
	EXISTING DEO/ELECTRIC		EXISTING ENWAVE/UNICOM MANHOLE		EXISTING GAS REDUCER		EXISTING FENCE		EXISTING CONSTRUCTION FENCE		EXISTING GUARDRAIL		EXISTING PROPERTY LINE/ R.O.W.
	EXISTING STREET LIGHT CONTROL BOX		EXISTING GAS MANHOLE		EXISTING MISCELLANEOUS MANHOLE		EXISTING GARBAGE CAN		EXISTING SEWER MAIN		EXISTING SEWER CATCH BASIN		EXISTING SEWER INLET
	EXISTING TRAFFIC LIGHT CONTROL BOX		EXISTING GAS VALVE		EXISTING SEWER MAIN (ABANDON)		EXISTING STORM SEWER MAIN		EXISTING MWRD MANHOLE		EXISTING WATER MAIN		EXISTING WATER MANHOLE
	EXISTING STREET LIGHT HANDHOLE		EXISTING GAS METER		EXISTING SEWER CATCH BASIN		EXISTING WATER SHUT OFF		EXISTING WATER VALVE		EXISTING WATER METER		EXISTING FIRE HYDRANT
	EXISTING TRAFFIC LIGHT HANDHOLE		EXISTING GAS METER		EXISTING SEWER INLET		EXISTING FIRE CISTERN MANHOLE		EXISTING WATER METER		EXISTING FIRE HYDRANT		EXISTING WATER REDUCER
	EXISTING RED LIGHT CAMERA POLE		EXISTING SUPPORT COLUMN		EXISTING WATER CAP		EXISTING FIRE HYDRANT		EXISTING WATER REDUCER		EXISTING WATER REDUCER		EXISTING WATER REDUCER

<u>COMMUNICATIONS</u>		<u>SEWER</u>		<u>WATER</u>	
	EXISTING AT&T		EXISTING SEWER MANHOLE		EXISTING WATER MANHOLE
	EXISTING AT&T (ABANDON)		EXISTING SEWER CATCH BASIN		EXISTING WATER VALVE
	EXISTING CROWN CASTLE		EXISTING SEWER INLET		EXISTING WATER METER
	EXISTING CABLE TV		EXISTING SEWER INLET		EXISTING FIRE HYDRANT
	EXISTING COMCAST		EXISTING SEWER INLET		EXISTING WATER REDUCER
	EXISTING COMMUNICATIONS		EXISTING SEWER INLET		EXISTING WATER REDUCER
	EXISTING LEVEL 3		EXISTING SEWER INLET		EXISTING WATER REDUCER
	EXISTING LOOKING GLASS		EXISTING SEWER INLET		EXISTING WATER REDUCER
	EXISTING JOINT BUILD		EXISTING SEWER INLET		EXISTING WATER REDUCER
	EXISTING McLEODUSA		EXISTING SEWER INLET		EXISTING WATER REDUCER
	EXISTING MCI/VERIZON		EXISTING SEWER INLET		EXISTING WATER REDUCER
	EXISTING NEXTG		EXISTING SEWER INLET		EXISTING WATER REDUCER
	EXISTING QWEST		EXISTING SEWER INLET		EXISTING WATER REDUCER
	EXISTING RCN		EXISTING SEWER INLET		EXISTING WATER REDUCER
	EXISTING SIDERA		EXISTING SEWER INLET		EXISTING WATER REDUCER
	EXISTING SPRINT/NEXTEL MANHOLE		EXISTING SEWER INLET		EXISTING WATER REDUCER
	EXISTING SUNESYS MANHOLE		EXISTING SEWER INLET		EXISTING WATER REDUCER
	EXISTING VERIZON MANHOLE		EXISTING SEWER INLET		EXISTING WATER REDUCER
	EXISTING WOW MANHOLE		EXISTING SEWER INLET		EXISTING WATER REDUCER
	EXISTING XO MANHOLE		EXISTING SEWER INLET		EXISTING WATER REDUCER
	EXISTING YIPES MANHOLE		EXISTING SEWER INLET		EXISTING WATER REDUCER
	EXISTING ZAYO GROUP MANHOLE		EXISTING SEWER INLET		EXISTING WATER REDUCER

REV	DATE	DESCRIPTION	BY
A	??/??/??	90% REVIEW	??

I HEREBY CERTIFY THAT THESE DRAWINGS WERE PREPARED BY ME OR UNDER MY DIRECT SUPERVISION AND CONTROL, AND TO THE BEST OF MY KNOWLEDGE AND BELIEF COMPLY WITH THE REQUIREMENTS OF ALL APPLICABLE CODES.

TASK NAME  
**07758.MX**

TASK DESCRIPTION  
**1300 PINE ST**

PROJECT AREA  
**LaCrosse, WI, USA**

SHEET SCALE  
**N.T.S.**

SHEET TITLE  
**LEGEND**

GRID NUMBER

SHEET NUMBER  
**T-3**

1. THE ENCLOSED DESIGN MAY IMPLY EXISTING UTILITIES. THE UTILITIES HAVE NOT BEEN FIELD VERIFIED FOR LOCATION. THEREFORE, ALL UTILITIES IMPLIED WITHIN THIS DOCUMENT ARE TO BE REFERRED TO AS A "REFERENCE TOOL". IT IS THE RESPONSIBILITY OF THE GENERAL CONTRACTOR AND/OR IT'S SUBCONTRACTOR TO VERIFY THESE UTILITIES USING ANY AND ALL METHODS AND INSTRUMENTS AVAILABLE IF/WHEN NECESSARY. FULLERTON CANNOT IN GOOD FAITH GUARANTEE UTILITY LOCATIONS. ANY AND ALL DOCUMENTATION ON EXISTING UTILITIES HAS BEEN IMPLIED UTILIZING INFORMATION RETRIEVAL PROCESSES FROM EACH JURISDICTION INVOLVED (STATE, COUNTY AND/OR MUNICIPALITY, TO INCLUDE OTHERS).
2. IT IS THE RESPONSIBILITY OF THE GENERAL CONTRACTOR TO ENSURE ALL CONDUITS ARE PLACED WITHIN THE GIVEN & DEDICATED SPACE LICENSED FOR THIS PARTICULAR CLIENT. FULLERTON ENGINEERING CONSULTANTS, INC. (FULLERTON) WAS NOT RETAINED FOR THE PURPOSE OF SUPPORTING A SURVEY OF THE AREA AND PROPERTY BOUNDARIES, THEREFORE FULLERTON CAN NOT AND WILL NOT SUPPORT THE ACCURACY OF ANY IMPLIED BOUNDARY (I.E. PUBLIC WAY, PRIVATE PROPERTY, EASEMENT ETC.) NOR IS IT TO BE ASSUMED THAT THE SALE OF PROPERTIES HAS NOT OCCURRED DURING & AFTER FULLERTON'S RESPONSIBILITIES FOR THIS PROJECT HAVE PAST. ALL BOUNDARIES, EASEMENTS, PROPERTY LINES, ETC. ARE TO BE USED AS A GUIDELINE OR REFERENCE AND SHOULD NOT BE TAKEN LITERALLY. IT IS THE CONTRACTOR'S RESPONSIBILITY TO HAVE ASSOCIATED BOUNDARIES SURVEY STAKED IF SO QUESTIONED. ALL ASPECTS OF BOUNDARIES IMPLIED HEREIN, HAVE BEEN DERIVED THROUGH AVAILABLE MEDIA SUCH AS BUT NOT LIMITED TO (SIDWELL, GOOGLE EARTH PRO. MUNICIPAL, STATE, COUNTY, GIS, AND OTHER RECORD TYPES). FULLERTON DOES NOT AGREE NOR DISAGREE WITH THE ABOVE-MENTIONED RECORDS AS THEY ARE USED JUST A REFERENCE TOOL.
3. ALL BURIED OBSTRUCTIONS KNOWN BY FULLERTON ARE SHOWN ON THE CONSTRUCTION DRAWINGS. ANY AND ALL OTHERS ENCOUNTERED DURING CONSTRUCTION ARE THE RESPONSIBILITY OF THE CONTRACTOR TO LOCATE AND PROTECT.
4. CONTRACTOR IS RESPONSIBLE FOR LOCATING ALL UTILITIES 48 HOURS PRIOR TO CONSTRUCTION ACTIVITY.
5. SHORING MAY BE REQUIRED AND SHALL COMPLY TO O.S.H.A. STANDARDS.
6. ALL BURIED CONDUIT/CABLE WILL BE PLACED AT 30-48" MINIMUM COVER UNLESS SPECIFIED OR OTHERWISE NOTED ON THE CONSTRUCTION DRAWINGS.
7. ANY AND ALL IMPROVEMENTS, IF DAMAGED, SHALL BE RESTORED TO ORIGINAL OR BETTER CONDITION. THIS INCLUDES BUT IS NOT LIMITED TO: ASPHALT, CONCRETE PAVEMENT, CURBS, GUTTERS, SIDEWALKS, DRAINAGE DITCHES, EMBANKMENTS, SHRUBS, TREES, GRASS SOD, ETC..
8. ALL FIBER INSTALLATIONS SHALL OBSERVE A MINIMUM DYNAMIC BEND RADIUS OF 20X THE CABLE DIAMETER FOR ALL OSP FIBER SHEATHS AND 15X THE CABLE DIAMETER FOR ALL ISP FIBER SHEATHS. ADDITIONALLY, ALL INSTALLATIONS SHALL OBSERVE A MINIMUM STATIC BEND RADIUS OF 15X THE CABLE DIAMETER FOR ALL OSP FIBER SHEATHS AND 10X THE CABLE DIAMETER FOR ALL ISP FIBER SHEATHS. IF THE MANUFACTURER'S SPECIFICATIONS FOR BEND RADIUS ARE GREATER, THEN THEY SHALL BE FOLLOWED.
9. ALL NEW METALLIC AERIAL STRAND SHALL BE BONDED/GROUNDED (PREFERABLY TO THE POWER COMPANY NEUTRAL) PER LOCAL REQUIREMENTS. AT A MINIMUM, THE BONDING/GROUNDING PATTERN SHALL BE THE FIRST AND LAST POLE OF A RUN AND EVERY TENTH POLE IN THE RUN. SHOULD ONE OF THESE DESIGNATED POLES SUPPORT A POWER TRANSFORMER, THE POLES ON EITHER SIDE OF SAID POLE SHALL BE BONDED/GROUNDED AND THE PATTERN SHOULD CONTINUE EVERY TENTH POLE FROM THAT STARTING POINT.
10. ALL AERIAL FIBER OPTIC CABLES SHALL BE SECURELY LASHED TO AERIAL STRAND BY METHOD OF MECHANICAL LASHING CARRIAGE OR APPROVED EQUAL.
11. ALL FIBER OPTIC CABLES INSTALLED BELOW GRADE SHALL BE OF AN ARMORED VARIETY WITH METALLIC INNER SHEATH, OR BE PLACED WITH A METALLIC LOCATING WIRE TO FACILITATE FUTURE LOCATING SERVICES.
12. ALL CONDUIT OR DUCT CONSTRUCTION SHALL INCLUDE THE PLACEMENT OF PULLING TAPE OF SUFFICIENT SIZE AND GRADE TO FACILITATE THE INSTALLATION OF THE SPECIFIED FIBER TYPE THROUGH CONDUIT BEING UTILIZED (JETLINE USE TO BE APPROVED BY CLIENT).
13. ALL FUSION SPLICING SHALL BE COMPLETED BY A QUALIFIED FIBER SPLICER IN A CLEAN TEMPERATURE CONTROLLED TRUCK, TRAILER, OR SHELTER SPECIFICALLY TOOLED OR DESIGNED FOR THE PURPOSE OF FUSION SPLICING FIBER OPTIC CABLES IN A FIELD ENVIRONMENT.
14. ALL MECHANICAL SPLICES AND FACTORY ENDS SHALL BE KEPT CLEAN AND FREE FROM DUST, DIRT, OILS, AND SMEARS. CARE SHOULD BE TAKEN TO MATCH POLISH TYPES ON FACTORY ENDS.
15. CONTRACTOR SHALL BE RESPONSIBLE FOR ANY AND ALL CORRECTIONS TO WORK IDENTIFIED AS UNACCEPTABLE BY CLIENT, ENGINEER, OR INSPECTOR, DURING SITE INSPECTION ACTIVITIES AND/OR AS A RESULT OF TESTING. CONTRACTOR SHALL ALSO PROVIDE ALL AS-BUILT INFORMATION UPON COMPLETION OF INSPECTION.
16. CONTRACTOR SHALL KEEP THE SITE FREE FROM ACCUMULATING WASTE MATERIAL, DEBRIS, AND TRASH. AT THE COMPLETION OF THE WORK, CONTRACTOR SHALL REMOVE FROM THE SITE ALL REMAINING RUBBISH, IMPLEMENTS, TEMPORARY FACILITIES, AND SURPLUS MATERIALS. CONTRACTOR TO RETURN SITE TO PREVIOUS OR BETTER CONDITION.
17. DRAWINGS ARE INTENDED TO SHOW DESIGN INTENT. CONTRACTOR SHALL PROVIDE MATERIALS AND LABOR AS REQUIRED TO PRODUCE A COMPLETE AND FUNCTIONING SYSTEM WHILE MEETING ALL CODES AND SPECIFICATIONS. MODIFICATIONS MAY BE REQUIRED TO SUIT JOB DIMENSIONS OR CONDITIONS. SUCH MODIFICATIONS SHALL BE INCLUDED IN THE WORK. SAID DESIGN IS INTENDED TO AVOID DISRUPTION OF ANY HANDICAP RAMPS OR STRUCTURES AS DESCRIBED PER THE AMERICANS WITH DISABILITIES ACT OF 1990.
18. CONTRACTOR SHALL WORK WITH CLIENT TO IDENTIFY ALL CONTRACTOR SUPPLIED MATERIALS TO CONSTRUCT NETWORK PER

SPECIFICATIONS.

19. THE CONTRACTOR SHALL PROVIDE ALL MATERIAL, EQUIPMENT, LABOR, INSTALLATION, RESTORATION, UTILITY RELOCATION CHARGES, JOB SITE DELIVERY COSTS AND INCIDENTALS TO COMPLETE THE DESCRIBED OR ILLUSTRATED WORK UNDER THIS CONTRACT.
20. ANY CHANGE-ORDER REQUEST MUST BE PRESENTED IN WRITING TO THE OWNER'S REPRESENTATIVE AND APPROVED PRIOR TO PROCEEDING WITH THE REQUESTED CHANGE.
21. THE ENGINEER WILL NOT BE RESPONSIBLE NOR ASSUME ANY LIABILITY FOR NEGLIGENT ACTS OR ERRORS OF OMISSIONS OF ANY CONTRACTOR, ANY SUBCONTRACTOR, OR ANY OF THE PERSONS (EXCEPT ENGINEER'S OWN EMPLOYEES) AT THE PROJECT SITE OR OTHERWISE PERFORMING ANY OF THE WORK OF THE PROJECT. ANY CONTRACTOR OR SUBCONTRACTOR, AS WELL AS THE ENGINEER, WILL BE RESPONSIBLE FOR HIS OWN SAFETY PROGRAM. NEITHER THE PROFESSIONAL ACTIVITIES OF THE ENGINEER, NOR THE PRESENCE OF THE ENGINEER OR HIS OR HER EMPLOYEES AND SUB-CONSULTANTS AT THE CONSTRUCTION SITE, SHALL RELIEVE ANY CONTRACTOR OF HIS OR HER OBLIGATIONS, DUTIES AND RESPONSIBILITIES INCLUDING, BUT NOT LIMITED TO, CONSTRUCTION MEANS, METHODS, SEQUENCE, TECHNIQUES OR PROCEDURES NECESSARY FOR PERFORMING, SUPERINTENDING OR COORDINATING ALL PORTIONS OF THE WORK OF CONSTRUCTION IN ACCORDANCE WITH THE CONTRACT DOCUMENTS AND ANY HEALTH OR SAFETY PRECAUTIONS REQUIRED BY ANY REGULATORY AGENCIES. THE ENGINEER AND HIS OR HER PERSONNEL HAVE NO AUTHORITY TO EXERCISE ANY CONTROL OVER ANY CONSTRUCTION CONTRACTOR OR OTHER ENTITY OR THEIR EMPLOYEES IN CONNECTION WITH ANY HEALTH OR SAFETY PRECAUTIONS.
22. ALL MATERIALS INSTALLED WITHIN THE LIMITS OF THIS PROJECT SHALL BE IN CONFORMANCE WITH STANDARD RECOMMENDATIONS OF THE NATIONAL ELECTRIC MANUFACTURER'S ASSOCIATION (NEMA) AND THE AMERICAN NATIONAL STANDARDS INSTITUTE (ANSI).
23. THE CONTRACTOR SHALL OBTAIN ALL PERMITS AND COMPLY WITH THE REQUIREMENTS OF ALL AGENCIES HAVING JURISDICTION OVER THE WORK AND SHALL COORDINATE HIS WORK WITH THE WORK PERFORMED BY OTHERS FOR THE PURPOSE OF INSTALLATION. THIS INCLUDES, BUT IS NOT LIMITED TO, ALL WORK WITH ALL PUBLIC AND PRIVATE UTILITIES AS WELL AS CITY AND STATE AGENCIES.
24. CONTRACTOR SHALL RECORD THE LOCATION AND ELEVATION OF ALL UTILITIES ENCOUNTERED, AND INSTALLATION OF NEW WORK, AS THE WORK PROGRESSES AND SHALL PREPARE RECORD DRAWINGS (RED-LINES) BASED ON HIS RECORDS. AS A PART OF THE RECORD DRAWINGS, CONTRACTOR SHALL ALSO PROVIDE HORIZONTAL AND VERTICAL CONFIGURATION OF CONDUITS WHERE MULTIPLE CONDUITS ARE INSTALLED. THESE RECORDS ARE TO BE SUPPLIED TO FULLERTON ENGINEERING AT COMPLETION OF WORK.
25. MAINTAIN MINIMUM OF 10 FEET HORIZONTAL SEPARATION FOR ALL CITY WATERMAIN AND 3 FEET MINIMUM HORIZONTAL SEPARATION FOR ALL OTHER CITY UTILITIES AND STRUCTURES
26. NO STORAGE OF EQUIPMENT OR MATERIALS IN THE ROADWAY IS PERMITTED UNLESS THE CONTRACTOR OBTAINS WRITTEN PERMISSION FROM THE CITY, STATE, AND/OR GOVERNING BODY.
27. CONTRACTOR RESPONSIBLE FOR OBTAINING AND PROVIDING REVIEW AND DESIGN OF ANY AND ALL SHORING SYSTEMS PRIOR TO CONSTRUCTION.
28. THE ENGINEER SHALL BE NOTIFIED FOR DISPOSITION OF SITUATIONS WHERE THE CONDUIT CANNOT MAINTAIN SEPARATIONS PER PLAN.
29. THE CONTRACTOR IS RESPONSIBLE FOR THE RESTORATION OF THE AREAS DISTURBED BY CONSTRUCTION ACTIVITIES. CONTRACTOR IS TO PAY ALL FEES AND OBTAIN ALL PERMITS FOR RESTORATION. CONTRACTOR IS TO RESTORE ALL DAMAGED STRUCTURES AND UTILITIES TO THE SATISFACTION OF THE FACILITY OWNER OR THE GOVERNING BODY, IN THE EVENT THAT DAMAGE OCCURS.
30. USE EXTREME CAUTION NEAR ALL GAS FACILITIES DURING CONSTRUCTION AND RELATED EXCAVATION ACTIVITIES, HAND EXCAVATION IS REQUIRED TO VERIFY THE HORIZONTAL AND VERTICAL LOCATION OF GAS MAIN(S) PRIOR TO CROSSING AND WORKING WITHIN 3 FEET OF ALL GAS FACILITIES. A MINIMUM OF 3 FEET HORIZONTAL EDGE TO EDGE CLEARANCE IS REQUIRED FOR GAS MAINS WITH DIAMETERS OF 16 INCHES OR SMALLER, AND 5 FEET EDGE TO EDGE CLEARANCE FOR GAS MAINS WITH DIAMETERS 18 INCHES AND LARGER IN DIAMETER. THE USE OF CONCRETE, FLOW FILL, OR THE LIKE IS PROHIBITED WITHIN 24 INCHES OF ALL GAS FACILITIES, NOR SHALL IT ENCASE ANY GAS FACILITY. SAND IS TO BE USED AS A BUFFER BETWEEN FLOWABLE FILL AND ALL GAS FACILITIES, ANY DAMAGE TO GAS FACILITIES SHALL BE THE RESPONSIBILITY OF THE INSTALLING UTILITY AND THEIR CONTRACTORS.



1100 E. WOODFIELD ROAD, SUITE 500  
SCHAUMBURG, ILLINOIS 60173  
TEL: 847-908-8400  
DESIGN FIRM NO. 184.008202-0006  
www.fullerton-us.com

REV	DATE	DESCRIPTION	BY
A	??/??/??	90% REVIEW	??

I HEREBY CERTIFY THAT THESE DRAWINGS WERE PREPARED BY ME OR UNDER MY DIRECT SUPERVISION AND CONTROL, AND TO THE BEST OF MY KNOWLEDGE AND BELIEF COMPLY WITH THE REQUIREMENTS OF ALL APPLICABLE CODES.

TASK NAME	<b>07758.MX</b>
TASK DESCRIPTION	<b>1300 PINE ST</b>
PROJECT AREA	LaCrosse, WI, USA
SHEET SCALE	N.T.S.
SHEET TITLE	<b>GENERAL NOTES</b>
GRID NUMBER	
SHEET NUMBER	<b>GN-1</b>





**metronet**

3701 COMMUNICATIONS WAY  
EVANSVILLE, IN, 47715

**Fullerton**  
DESIGN DEVELOP CONSTRUCT

1100 E. WOODFIELD ROAD, SUITE 500  
SCHAUMBURG, ILLINOIS 60173  
TEL: 847-908-8400  
DESIGN FIRM NO. 184.008202-0006  
www.fullerton-us.com



REV	DATE	DESCRIPTION	BY
A	??/??/??	90% REVIEW	??

I HEREBY CERTIFY THAT THESE DRAWINGS WERE PREPARED BY ME OR UNDER MY DIRECT SUPERVISION AND CONTROL, AND TO THE BEST OF MY KNOWLEDGE AND BELIEF COMPLY WITH THE REQUIREMENTS OF ALL APPLICABLE CODES.

TASK NAME  
**07758.MX**

TASK DESCRIPTION  
**1300 PINE ST**

PROJECT AREA  
**LaCrosse, WI, USA**

SHEET SCALE  
**N.T.S.**

SHEET TITLE  
**MAP**

GRID NUMBER

SHEET NUMBER  
**MAP-1**

PLANSET

11'x17' SCALE: NTS  
24'x36' SCALE: NTS

I

PROJECT#      ????

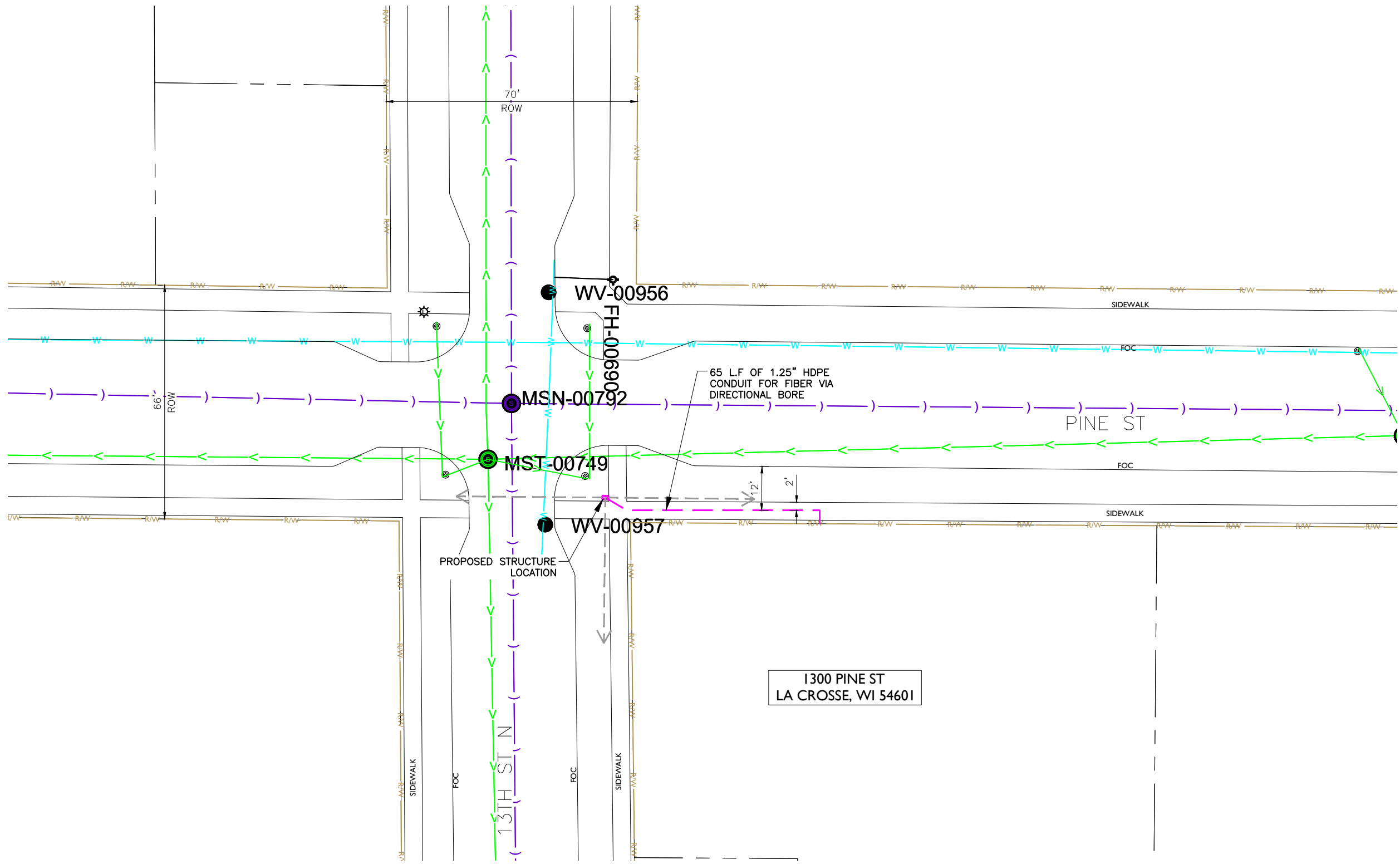

REV	DATE	DESCRIPTION	BY
A	??/??/??	90% REVIEW	??

I HEREBY CERTIFY THAT THESE DRAWINGS WERE PREPARED BY ME OR UNDER MY DIRECT SUPERVISION AND CONTROL, AND TO THE BEST OF MY KNOWLEDGE AND BELIEF COMPLY WITH THE REQUIREMENTS OF ALL APPLICABLE CODES.

TASK NAME  
**07758.MX**

TASK DESCRIPTION  
**1300 PINE ST**

PROJECT AREA  
LaCrosse, WI, USA

SHEET SCALE  
**1" = 30'-0"**

SHEET TITLE  
**DESIGN LAYOUT**

GRID NUMBER

SHEET NUMBER  
**C-01**

- NOTE:
- PROPOSED CONDUIT SHALL AVOID EXISTING SEEPAGE BEDS
  - MAINTAIN 3' CLEARANCE FROM EXISTING CITY UTILITY STRUCTURES
  - BURY AT 24" MIN. UNDER SOFT SURFACE-BURY AT 36" MIN. UNDER HARD SURFACE
  - MAINTAIN 1' FROM BACK OF SIDEWALK, WHEN APPLICABLE.
  - SEE SHEETS TCP-1 THROUGH TCP-6 FOR TRAFFIC CONTROL PLANS



**ADDITIONAL NOTES:**

1. EXCEPT AS OTHERWISE NOTED, CONTRACTOR SHALL MAINTAIN A MINIMUM OF 24 INCHES OF SEPARATION FROM EXISTING UTILITIES.
2. CONTRACTOR SHALL POTHOLE EACH UTILITY TO DETERMINE SIZE, LOCATION, AND DEPTH PRIOR TO CROSSING.
3. CONTRACTOR IS CAUTIONED TO PROTECT SEWER MANHOLES, CATCH BASINS, LATERALS AND INLETS.
4. CONTRACTOR WILL PROVIDE BARRICADING TO INSURE CORRECT TRAFFIC CONTROL WHILE MAINTAINING VEHICULAR TRAFFIC AT ALL TIMES.
5. RESTORATION TO BE IN COMPLIANCE WITH APPLICABLE PERMITTING AGENCIES.
6. BONDING AND GROUNDING PER NESC.

**PUBLIC UTILITY NOTE:**

CONTRACTOR SHALL NOTIFY ALL PUBLIC UTILITY COMPANIES (GAS, ELECTRIC, TELEPHONE, SEWER, WATER, ETC) PRIOR TO COMMENCING ANY CONSTRUCTION. THESE COMPANIES WILL LOCATE, ON THE GROUND, THE LOCATION OF ALL CONDUITS, DUCTS, UNDERGROUND PIPING, ETC., ADJOINING & CROSSING PROPOSED CONSTRUCTION.

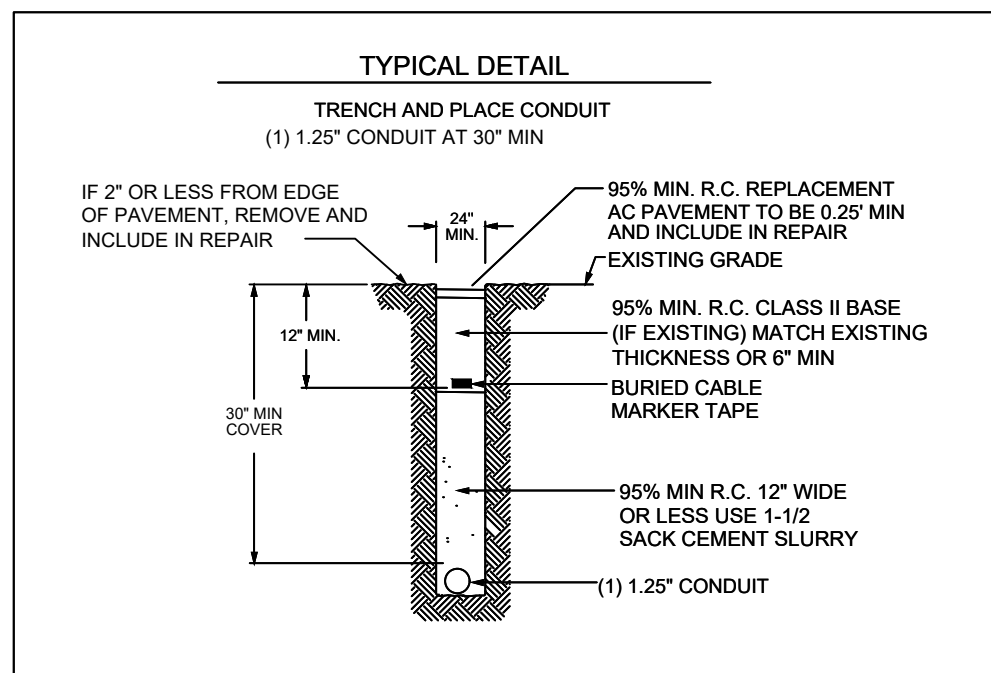
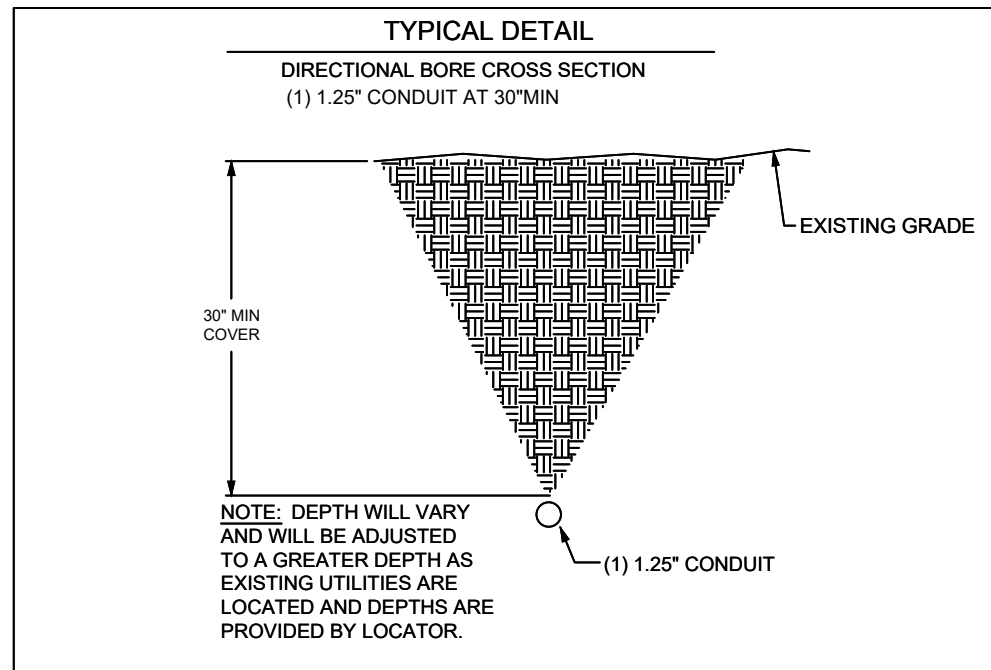

REV	DATE	DESCRIPTION	BY
A	??/??/??	90% REVIEW	??

I HEREBY CERTIFY THAT THESE DRAWINGS WERE PREPARED BY ME OR UNDER MY DIRECT SUPERVISION AND CONTROL, AND TO THE BEST OF MY KNOWLEDGE AND BELIEF COMPLY WITH THE REQUIREMENTS OF ALL APPLICABLE CODES.

TASK NAME  
**07758.MX**

TASK DESCRIPTION  
**1300 PINE ST**

PROJECT AREA  
 LaCrosse, WI, USA

SHEET SCALE  
 N.T.S.

SHEET TITLE  
**DETAILS**

GRID NUMBER

SHEET NUMBER  
**D-1**



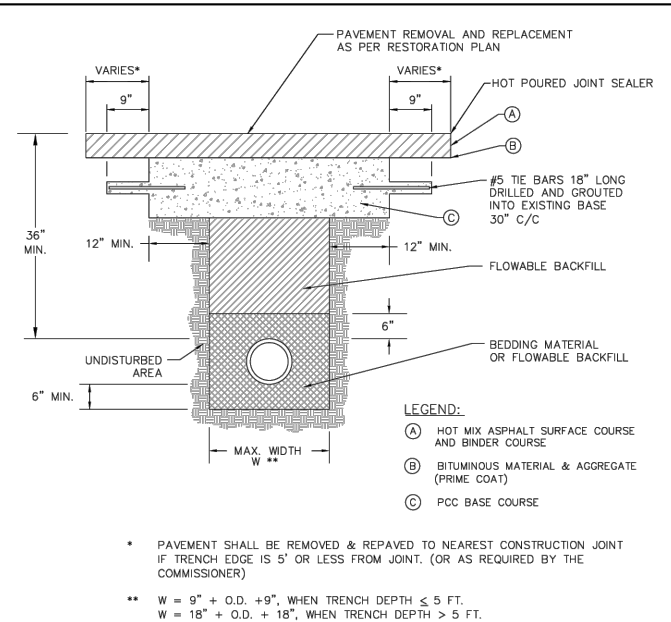

\* PAVEMENT SHALL BE REMOVED & REPAVED TO NEAREST CONSTRUCTION JOINT IF TRENCH EDGE IS 5' OR LESS FROM JOINT. (OR AS REQUIRED BY THE COMMISSIONER)

\*\* W = 9" + O.D. + 9", WHEN TRENCH DEPTH ≤ 5 FT.  
W = 18" + O.D. + 18", WHEN TRENCH DEPTH > 5 FT.

**NOTES:**

1. THE PORTLAND CEMENT CONCRETE BASE SHALL BE 8" OR MORE (SEE SECTION 4.2b FOR REQUIRED THICKNESS). FOR CONCRETE STREETS THE CONCRETE SHALL BE BROUGHT TO GRADE (INCLUDING 1"-0" OVERLAP) AND FINISHED AS REQUIRED IN THE IDOT SSRBC.
2. ALL EXISTING PAVEMENTS SHALL BE SAW CUT 1"-0" ON BOTH SIDES OF THE TRENCH OR PAVEMENT OPENING. UNDER NO CIRCUMSTANCES SHOULD EXISTING PAVEMENT, WHICH HAS BEEN UNDERMINED OR OTHERWISE DISTURBED, BE LEFT IN PLACE AND NOT RESTORED.
3. ALL STREET PAVEMENT WILL REQUIRE PLACEMENT OF #5 TIE BARS, 18 INCHES LONG DRILLED AND GROUTED (NON SHRINK) AT 30" CENTERS ON ALL SIDES. A MINIMUM OF TWO TIE BARS WILL BE REQUIRED ON EACH SIDE OF SAW CUT BOUNDARIES.
4. ALL TIE BARS AND DOWEL BARS ARE TO BE EPOXY COATED (INCIDENTAL).

CDOT CHICAGO DEPARTMENT OF TRANSPORTATION	DATE	REVISION	CITY OF CHICAGO		
	1/1/2014	REVISION 1	STREET PAVEMENT RESTORATION		
	1/27/2016	REVISION 2	DETAIL WITH FLOWABLE FILL		
	DATE	SHEET	DRAWN BY		
	01/11/07	A-2-2B	CDOT		

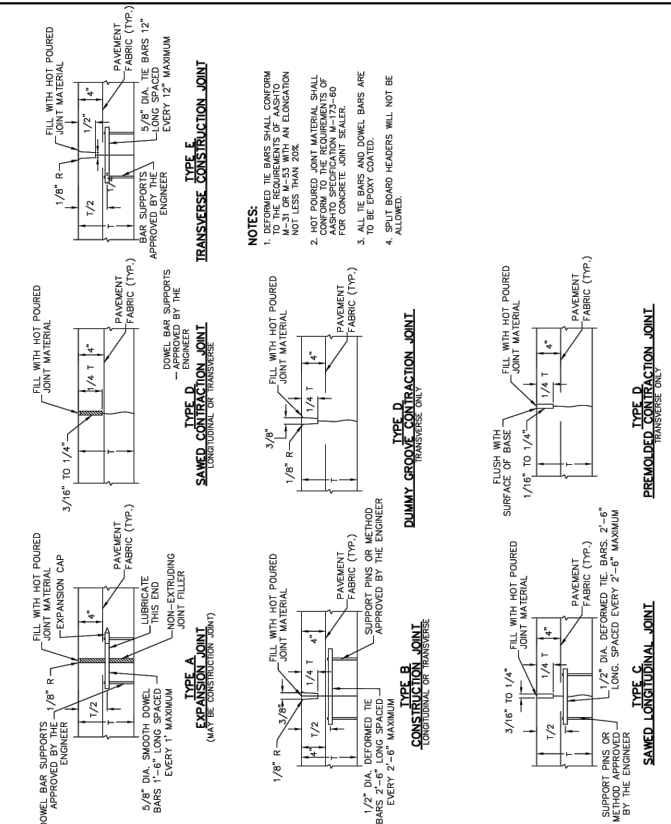

CDOT CHICAGO DEPARTMENT OF TRANSPORTATION	DATE	REVISION	CITY OF CHICAGO		
	1/1/2014	REVISION 1	P.C.C. PAVEMENT JOINT DETAILS		
			DATE	SHEET	DRAWN BY
	12/26/06	A-2-3B	CDOT		

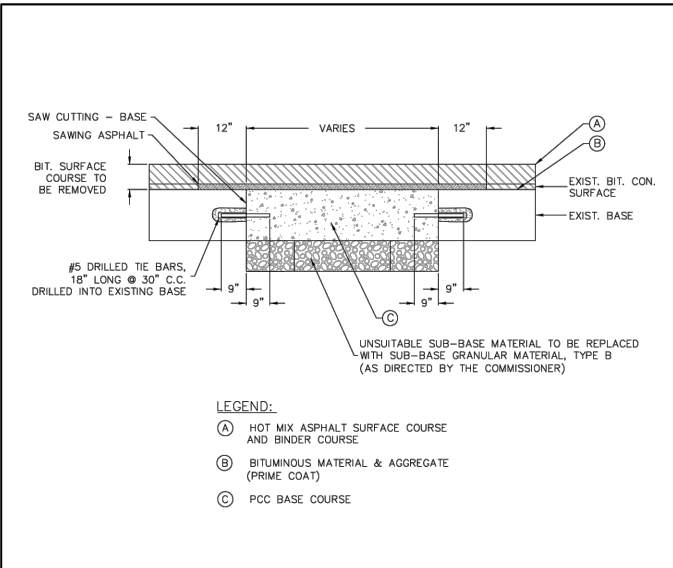

**NOTES:**

1. THE PORTLAND CEMENT CONCRETE BASE SHALL BE 8" OR MORE (SEE SECTION 4.2b FOR REQUIRED THICKNESS). FOR CONCRETE STREETS THE CONCRETE SHALL BE BROUGHT TO GRADE (INCLUDING 1"-0" OVERLAP) AND FINISHED AS REQUIRED IN THE IDOT SSRBC.
2. ALL EXISTING PAVEMENTS SHALL BE SAW CUT 1"-0" ON BOTH SIDES OF THE TRENCH OR PAVEMENT OPENING. UNDER NO CIRCUMSTANCES SHOULD EXISTING PAVEMENT, WHICH HAS BEEN UNDERMINED OR OTHERWISE DISTURBED, BE LEFT IN PLACE AND NOT RESTORED.
3. ALL STREET PAVEMENT WILL REQUIRE PLACEMENT OF #5 TIE BARS, 18 INCHES LONG DRILLED AND GROUTED (NON SHRINK) AT 30" CENTERS ON ALL SIDES. A MINIMUM OF TWO TIE BARS WILL BE REQUIRED ON EACH SIDE OF SAW CUT BOUNDARIES.
4. ALL TIE BARS AND DOWEL BARS ARE TO BE EPOXY COATED (INCIDENTAL).

CDOT CHICAGO DEPARTMENT OF TRANSPORTATION	DATE	REVISION	CITY OF CHICAGO		
	1/1/2014	REVISION 1	PAVEMENT PATCHING AND PORTLAND CEMENT CONCRETE REPLACEMENT		
	1/27/2016	REVISION 2			
	DATE	SHEET	DRAWN BY		
	01/11/07	A-2-2C	CDOT		

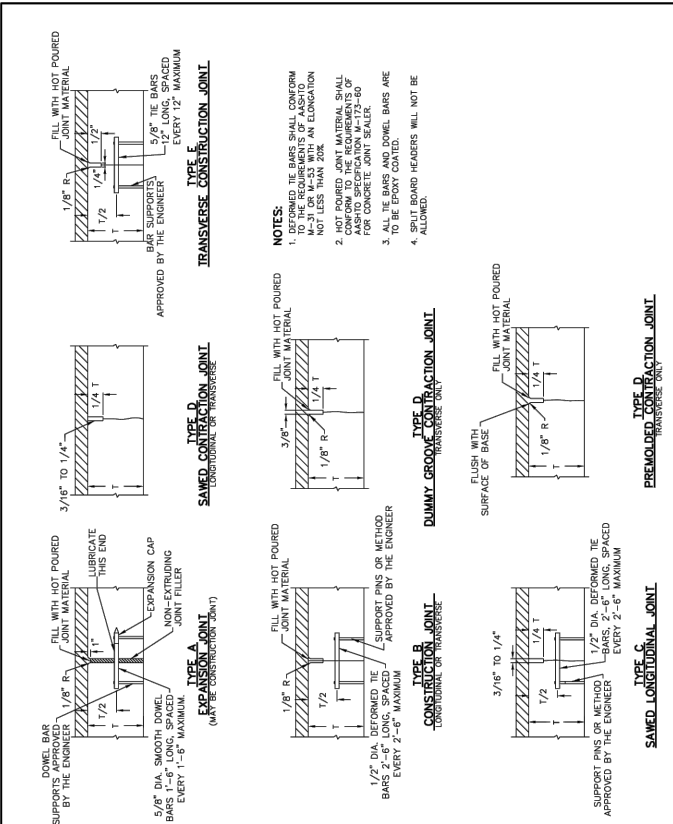

CDOT CHICAGO DEPARTMENT OF TRANSPORTATION	DATE	REVISION	CITY OF CHICAGO		
	1/1/2014	REVISION 1	P.C.C. BASE COURSE JOINT DETAILS		
			DATE	SHEET	DRAWN BY
	12/27/06	A-2-3C	CDOT		

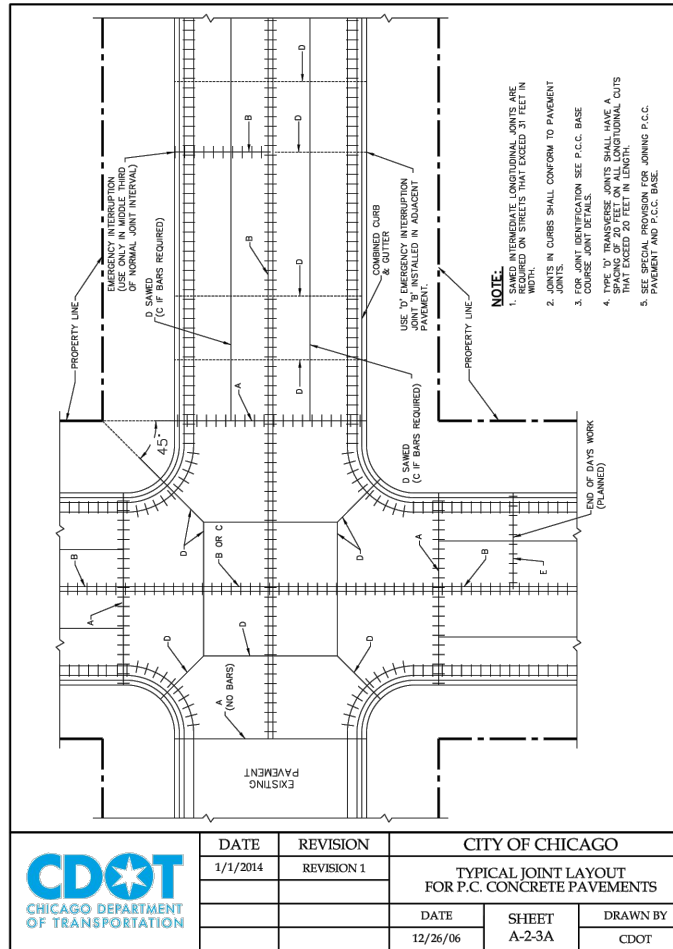

CDOT CHICAGO DEPARTMENT OF TRANSPORTATION	DATE	REVISION	CITY OF CHICAGO		
	1/1/2014	REVISION 1	TYPICAL JOINT LAYOUT FOR P.C. CONCRETE PAVEMENTS		
			DATE	SHEET	DRAWN BY
	12/26/06	A-2-3A	CDOT		

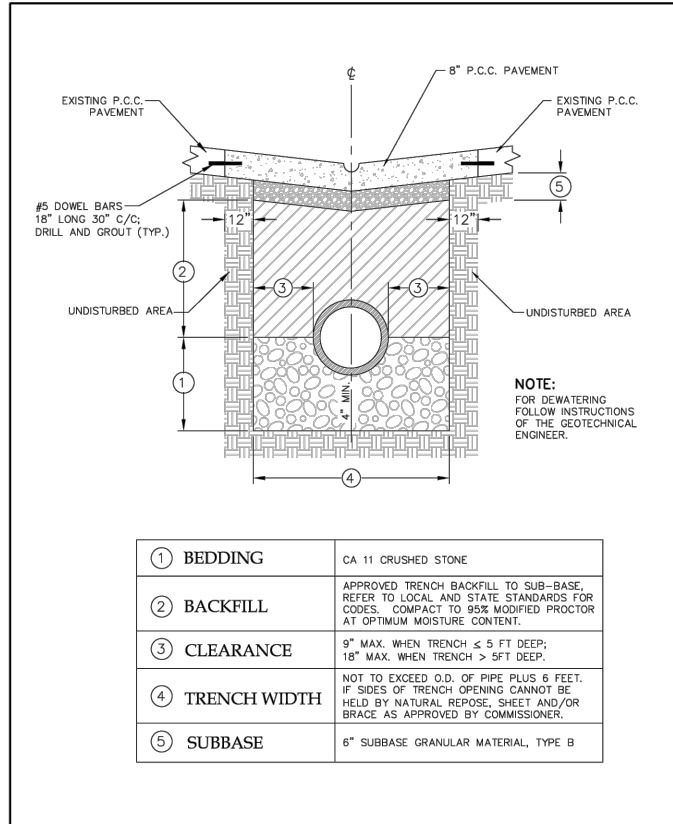

1	BEDDING	CA 11 CRUSHED STONE
2	BACKFILL	APPROVED TRENCH BACKFILL TO SUB-BASE. REFER TO LOCAL AND STATE STANDARDS FOR CODES. COMPACT TO 95% MODIFIED PROCTOR AT OPTIMUM MOISTURE CONTENT.
3	CLEARANCE	9" MAX. WHEN TRENCH ≤ 5 FT DEEP; 18" MAX. WHEN TRENCH > 5 FT DEEP.
4	TRENCH WIDTH	NOT TO EXCEED O.D. OF PIPE PLUS 6 FEET. IF SIDES OF TRENCH OPENING CANNOT BE HELD BY NATURAL REPOSE, SHEET AND/OR BRACE AS APPROVED BY COMMISSIONER.
5	SUBBASE	6" SUBBASE GRANULAR MATERIAL, TYPE B

CDOT CHICAGO DEPARTMENT OF TRANSPORTATION	DATE	REVISION	CITY OF CHICAGO		
	1/1/2014	REVISION 1	P.C.C. ALLEY PAVEMENT RESTORATION PIPE OR CONDUIT TRENCH DETAIL, CONCRETE ALLEY		
			DATE	SHEET	DRAWN BY
	12/20/06	A-2-7	CDOT		

metronet™

3701 COMMUNICATIONS WAY  
EVANSVILLE, IN, 47715

Fullerton  
DESIGN DEVELOP CONSTRUCT

1100 E. WOODFIELD ROAD, SUITE 500  
SCHAUMBURG, ILLINOIS 60173  
TEL: 847-908-8400  
DESIGN FIRM NO. 184.008202-0006  
www.fullerton-us.com

REV	DATE	DESCRIPTION	BY
A	??/??/??	90% REVIEW	??

I HEREBY CERTIFY THAT THESE DRAWINGS WERE PREPARED BY ME OR UNDER MY DIRECT SUPERVISION AND CONTROL, AND TO THE BEST OF MY KNOWLEDGE AND BELIEF COMPLY WITH THE REQUIREMENTS OF ALL APPLICABLE CODES.

TASK NAME

07758.MX

TASK DESCRIPTION

1300 PINE ST

PROJECT AREA

LaCrosse, WI, USA

SHEET SCALE

N.T.S.

SHEET TITLE

DETAILS

GRID NUMBER

SHEET NUMBER

D-2



REV	DATE	DESCRIPTION	BY
A	??/??/??	90% REVIEW	??

I HEREBY CERTIFY THAT THESE DRAWINGS WERE PREPARED BY ME OR UNDER MY DIRECT SUPERVISION AND CONTROL, AND TO THE BEST OF MY KNOWLEDGE AND BELIEF COMPLY WITH THE REQUIREMENTS OF ALL APPLICABLE CODES.

TASK NAME

07758.MX

TASK DESCRIPTION

1300 PINE ST

PROJECT AREA

LaCrosse, WI, USA

SHEET SCALE

N.T.S.

SHEET TITLE

DETAILS

GRID NUMBER

SHEET NUMBER

D-3

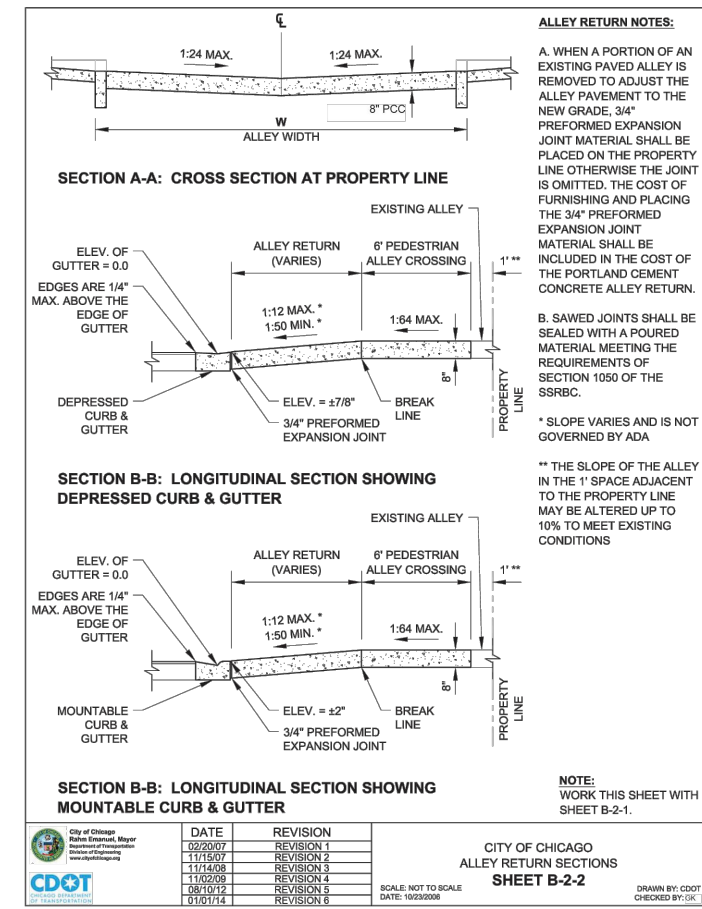

DATE	REVISION
02/20/07	REVISION 1
11/15/07	REVISION 2
11/14/08	REVISION 3
11/02/09	REVISION 4
08/10/12	REVISION 5
01/01/14	REVISION 6

CITY OF CHICAGO  
ALLEY RETURN SECTIONS  
**SHEET B-2-2**

SCALE: NOT TO SCALE  
DATE: 10/23/2008  
DRAWN BY: CDOT  
CHECKED BY: EK

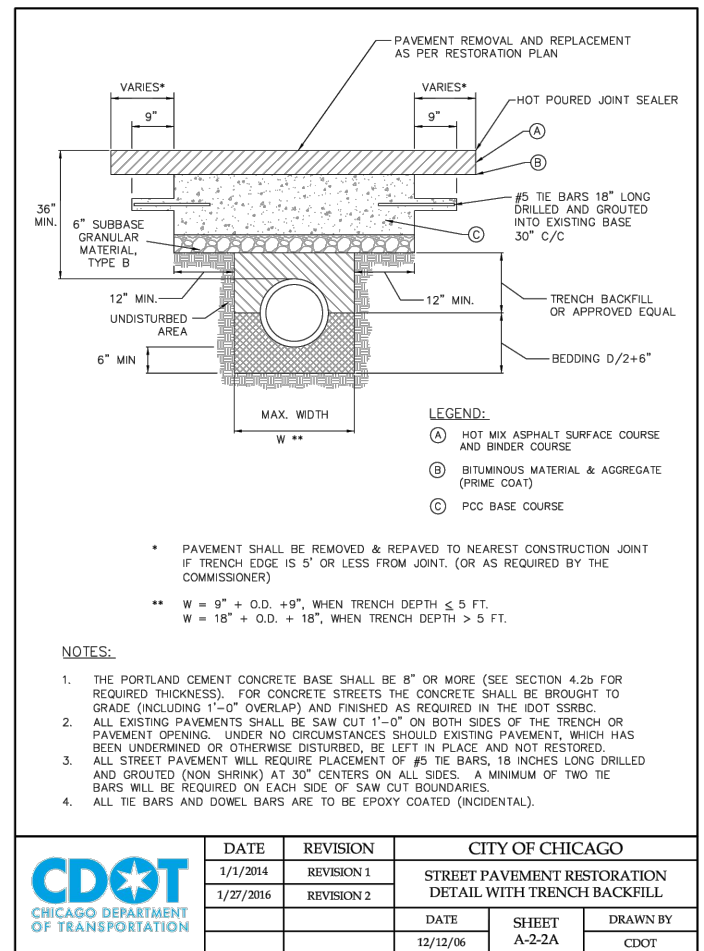

DATE	REVISION
1/1/2014	REVISION 1
1/27/2016	REVISION 2

CITY OF CHICAGO  
STREET PAVEMENT RESTORATION  
DETAIL WITH TRENCH BACKFILL

DATE: 12/12/06  
SHEET: A-2-2A  
DRAWN BY: CDOT

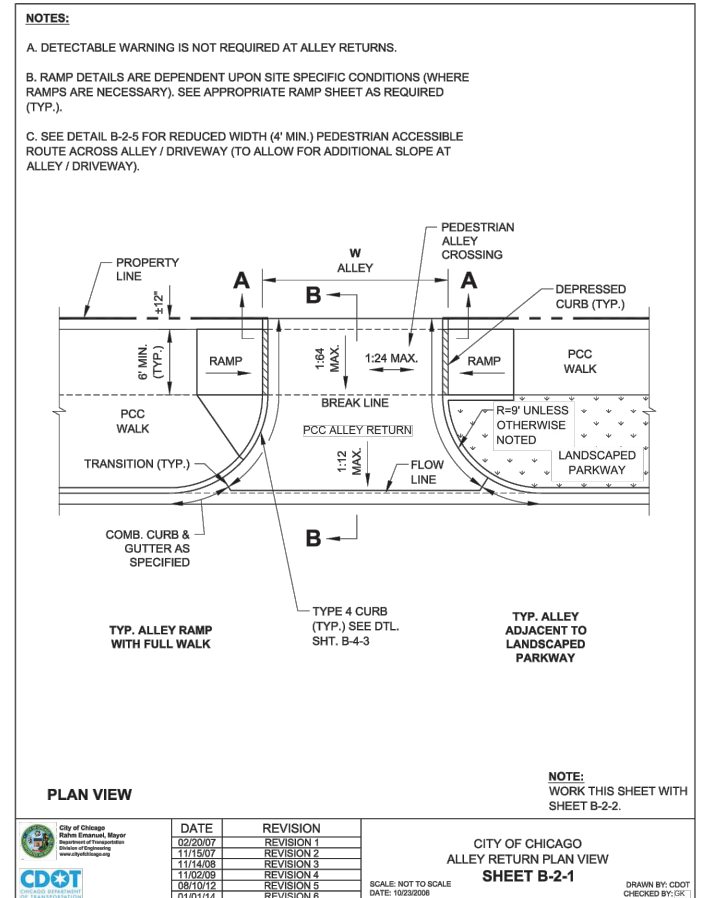

DATE	REVISION
02/20/07	REVISION 1
11/15/07	REVISION 2
11/14/08	REVISION 3
11/02/09	REVISION 4
08/10/12	REVISION 5
01/01/14	REVISION 6

CITY OF CHICAGO  
ALLEY RETURN PLAN VIEW  
**SHEET B-2-1**

SCALE: NOT TO SCALE  
DATE: 10/23/2008  
DRAWN BY: CDOT  
CHECKED BY: EK

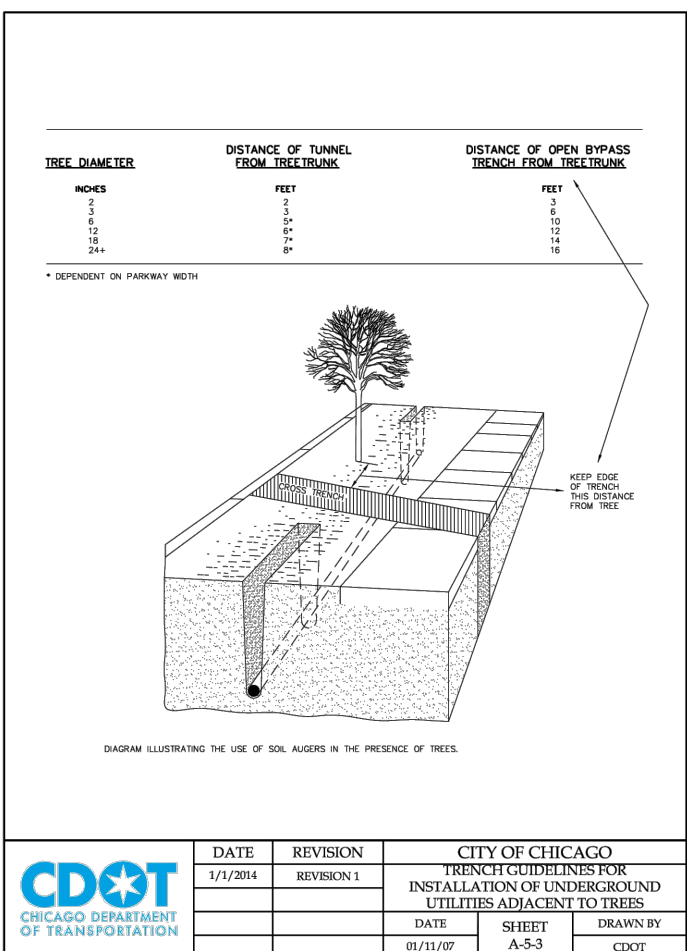

DATE	REVISION
1/1/2014	REVISION 1

CITY OF CHICAGO  
TRENCH GUIDELINES FOR  
INSTALLATION OF UNDERGROUND  
UTILITIES ADJACENT TO TREES

DATE: 01/11/07  
SHEET: A-5-3  
DRAWN BY: CDOT

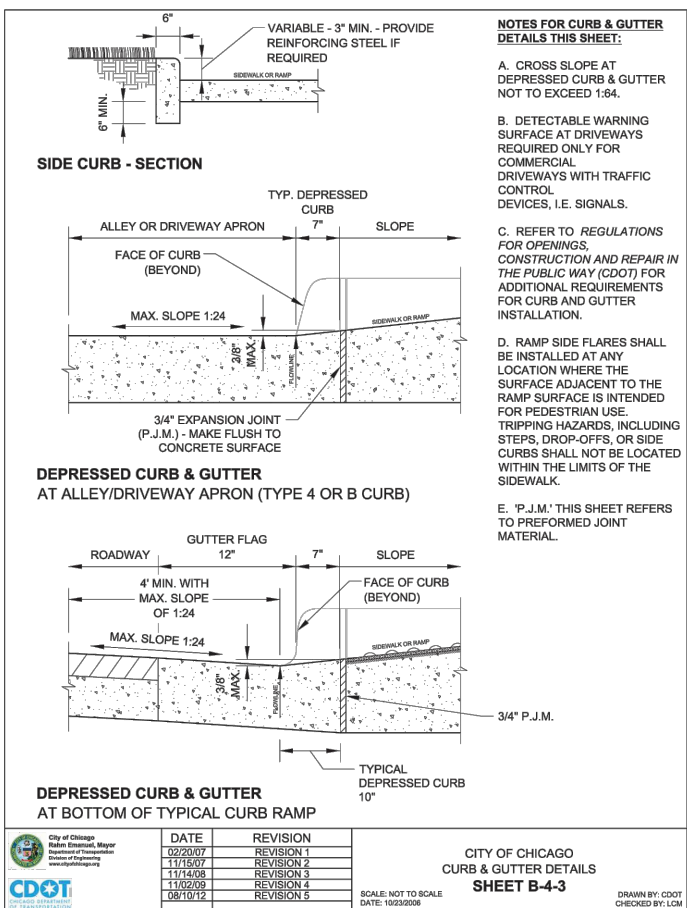

DATE	REVISION
02/20/07	REVISION 1
11/15/07	REVISION 2
11/14/08	REVISION 3
11/02/09	REVISION 4
08/10/12	REVISION 5

CITY OF CHICAGO  
CURB & GUTTER DETAILS  
**SHEET B-4-3**

SCALE: NOT TO SCALE  
DATE: 10/23/2008  
DRAWN BY: CDOT  
CHECKED BY: LCM

BULK 3 Series

TECHNICAL SPECIFICATIONS

BODY SPECIFICATIONS

Cover Weight 26 lbs [12 kg]  
 Pit Weight 63 lbs [29 kg]  
 Assembled Weight 89 lbs [41 kg]

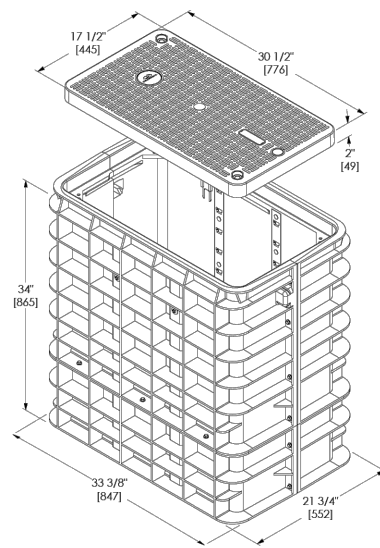
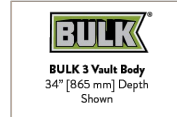
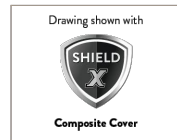

ADDITIONAL BODY DEPTHS

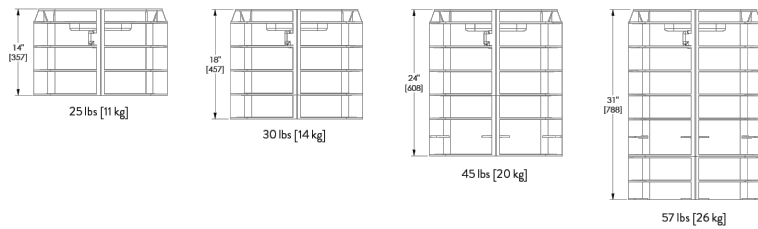

BULK 4 Series

TECHNICAL SPECIFICATIONS

BODY SPECIFICATIONS

Cover Weight 50 lbs [23 kg]  
 Pit Weight 82 lbs [37 kg]  
 Assembled Weight 132 lbs [60 kg]

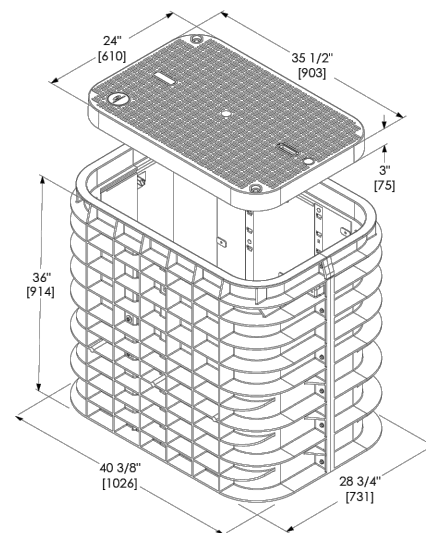
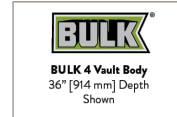

ADDITIONAL BODY DEPTHS

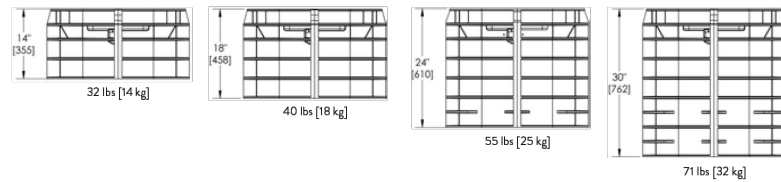

BULK 7 Series

TECHNICAL SPECIFICATIONS

BODY SPECIFICATIONS

Cover Weight (Split 1/2 Cover) 50 lbs [23 kg]  
 Pit Weight 129 lbs [59 kg]  
 Assembled Weight 229 lbs [105 kg]

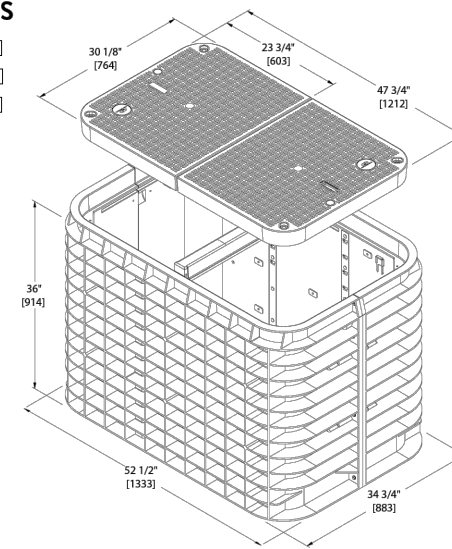

ADDITIONAL BODY DEPTHS

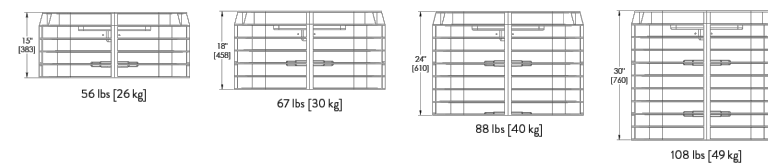

3701 COMMUNICATIONS WAY  
 EVANSVILLE, IN, 47715



1100 E. WOODFIELD ROAD, SUITE 500  
 SCHAUMBURG, ILLINOIS 60173  
 TEL: 847-908-8400  
 DESIGN FIRM NO. 184.008202-0006  
 www.fullerton-us.com

REV	DATE	DESCRIPTION	BY
A	??/??/??	90% REVIEW	??

I HEREBY CERTIFY THAT THESE DRAWINGS WERE PREPARED BY ME OR UNDER MY DIRECT SUPERVISION AND CONTROL, AND TO THE BEST OF MY KNOWLEDGE AND BELIEF COMPLY WITH THE REQUIREMENTS OF ALL APPLICABLE CODES.

TASK NAME

07758.MX

TASK DESCRIPTION

1300 PINE ST

PROJECT AREA

LaCrosse, WI, USA

SHEET SCALE

N.T.S.

SHEET TITLE

DETAILS

GRID NUMBER

SHEET NUMBER

D-4





# DATA SHEET

## SGLB-0 NEW SIGNATURE SERIES GRADE LEVEL BOX WITH SELFLOCK™ PROTECTION



### SIMPLE AND WORRY FREE PROTECTION



SELFLOCK™ closes and seals with audible "Click"



Captive bolt device opens with only 1/4 turn



Shown with Optional Marker Locate Device

### DIMENSIONS

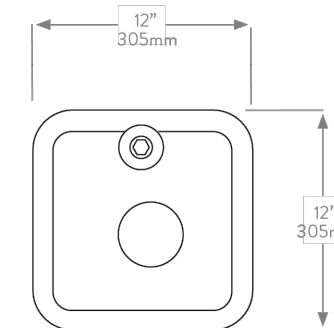
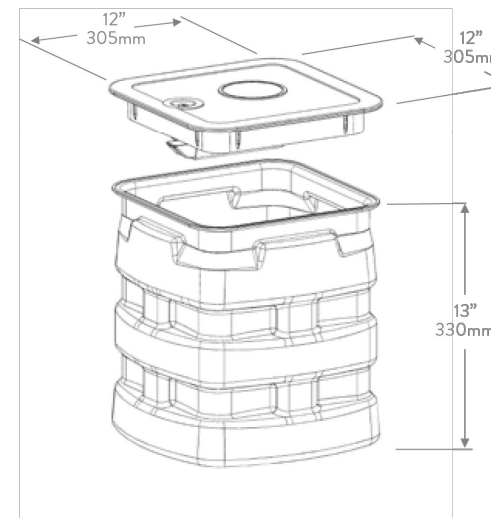

# SELFLOCK™

The New Signature Series SGLB High Density Polyethylene (HDPE) grade level box line come standard with Logo Disk and the Patented SELFLOCK™ automatic locking mechanism.

### FEATURES

- 13" (330mm) Depth
- No bolts to be lost, misplaced, or not installed back into the unit

- Captive bolt device, that opens with a 1/4 turn
- Press/Push lid closed, and it will automatically lock in place (with an audible "click")
- Protects your investment, and ensures the needed protection for your network
- Eliminates the risk of lids floating off, being throw be lawnmowers (i.e. reduces potentially liability)



## CHANNELL

Where The Industry Connects.

WORLDWIDE HEADQUARTERS: Channell Commercial Corporation, Rockwall, TX, United States • Tel 800.423.1863 • Fax 951.296.2322

CANADA: Channell Canada, Inc., Mississauga, ON, Canada • Tel 905.565.1700 • Fax 905.565.8282

EUROPE, MIDDLE EAST, AFRICA: Channell Ltd., Dartford, United Kingdom • Tel 44.1322.312590 • Fax 44.1322.508490

AUSTRALIA, ASIA, PACIFIC RIM: Channell Pty. Ltd., Seven Hills, NSW, Australia • Tel 61.2.8884.4111 • Fax 61.2.8814.8841

www.channell.com

All specifications subject to change without notice. © 2022 Channell Commercial Corporation. All rights reserved.

040822 FRT

# metronet™

3701 COMMUNICATIONS WAY  
EVANSVILLE, IN, 47715

## Fullerton

DESIGN DEVELOP CONSTRUCT

1100 E. WOODFIELD ROAD, SUITE 500  
SCHAUMBURG, ILLINOIS 60173  
TEL: 847-908-8400  
DESIGN FIRM NO. 184.008202-0006  
www.fullerton-us.com

REV	DATE	DESCRIPTION	BY
A	??/??/??	90% REVIEW	??

I HEREBY CERTIFY THAT THESE DRAWINGS WERE PREPARED BY ME OR UNDER MY DIRECT SUPERVISION AND CONTROL, AND TO THE BEST OF MY KNOWLEDGE AND BELIEF COMPLY WITH THE REQUIREMENTS OF ALL APPLICABLE CODES.

TASK NAME

07758.MX

TASK DESCRIPTION

1300 PINE ST

PROJECT AREA

LaCrosse, WI, USA

SHEET SCALE

N.T.S.

SHEET TITLE

DETAILS

GRID NUMBER

SHEET NUMBER

D-5

PROJECT# ????

**NOTES:**

1. CALL FOR LOCATES AT LEAST 72 HOURS IN ADVANCE OF ANY CONSTRUCTION FOR MARKINGS.
2. FOR LABEL AND TAG INFORMATION SEE DRAWING OSP 16.
3. THE VAULT W/ BOTTOM ENTRY ELEVATION VIEW SHOWN BELOW ONLY INDICATES THE BACK FILL REQUIREMENTS NECESSARY FOR VAULTS PLACED IN SIDEWALKS, ETC. (WHERE THEY NEED TO COMPLY WITH ADA REQUIREMENTS). TO ENSURE COMPLIANCE WITH CURRENT ADA REQUIREMENTS, THE HEIGHT OF THE BACK FILL IS SHOWN HELD DOWN TO ALLOW CONCRETE TO FLOW DOWN AND AROUND THE LIFTING LUGS/BOLTS WHICH WILL SERVE AS DOWELS INTO THE FINISHED CONCRETE SLAB.

**ADA REQUIREMENTS:**

**SURFACE LEVEL CRITERIA:** NO HEIGHT DIFFERENTIALS WITH A RISE GREATER THAN 1/4" IN HEIGHT. EXCEPTIONS: A HEIGHT DIFFERENTIAL BETWEEN 1/4" AND 1/2" IS ACCEPTABLE IF IT IS BEVELED AT A 2:1 SLOPE, OR A HEIGHT DIFFERENTIAL GREATER THAN 1/2" IS ACCEPTABLE IF IT IS RAMPED WITH A SLOPE OF 8.33% (1X:12H) OR LESS.

UTILITY COVERS SHALL HAVE A SLIP RESISTANT TOP, AS MUCH AS POSSIBLE, AND MEET CHANGES IN LEVEL CRITERIA AS STATED ABOVE.

LIFT HOLES FOR UTILITY COVERS SHALL NOT HAVE AN OPENING GREATER THAN 1/2". PLUGGING OF HOLES GREATER THAN 1/2" WITH A MATERIAL APPROVED BY THE ENGINEER IS ACCEPTABLE AS LONG AS IT IS FLUSH WITH THE COVER SURFACE.

A LEVEL PEDESTRIAN ACCESS ROUTE (PAR) OR WALKWAY SHALL BE PROVIDED ACROSS COMMERCIAL AND RESIDENTIAL ENTRANCES, MEETING THE FOLLOWING CRITERIA:  
 - THE WALKWAY IS AT MINIMUM 3' WIDE.  
 - CROSS SLOPE OF WALKWAY IS 2% OR LESS.  
 - WALKWAY IS AT THE SAME GRADE AS THE ADJACENT ROADWAY.  
 - THE WALKWAY DOES NOT HAVE TO BE MARKED, BUT PROVIDES A STRAIGHT LINE BETWEEN THE ADJOINING SIDEWALKS OR RAMPS.  
 - THERE IS NOT AN ABRUPT TRANSITION FROM THE DRIVEWAY TO THE ROADWAY FOR VEHICLES, I.E., VEHICLES WILL NOT BOTTOM OUT WHEN DRIVING OVER THE TRANSITION.

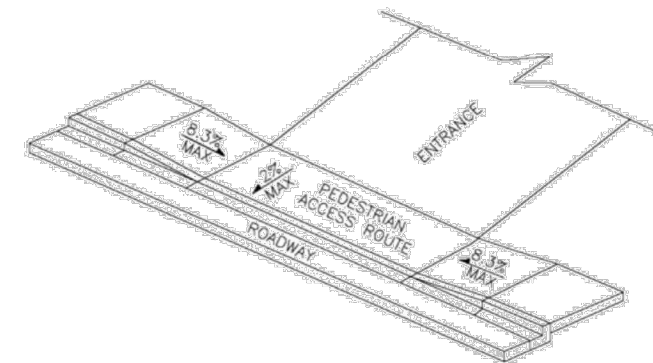
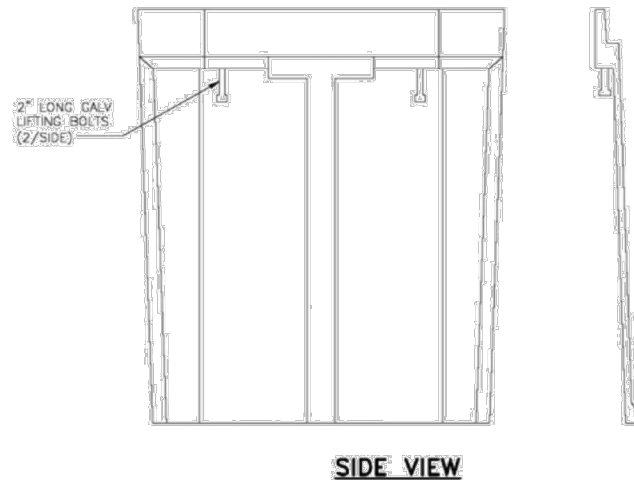
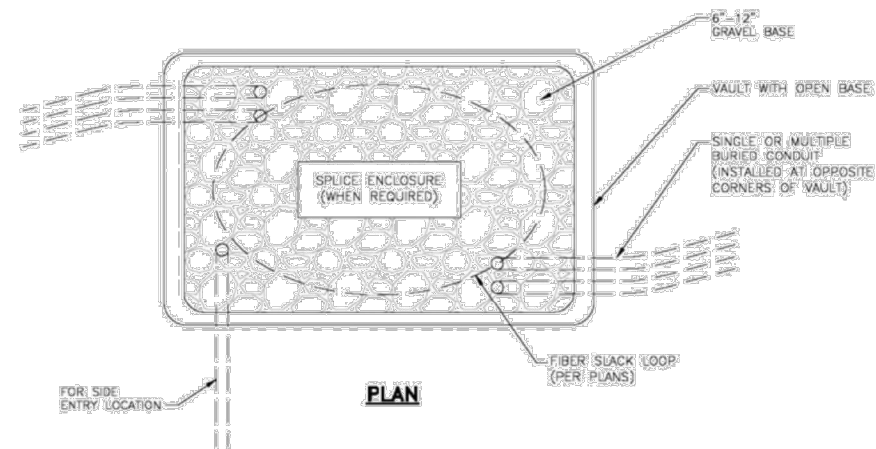

**NOTE:**

1. ENCLOSURES, BOXES AND COVERS ARE REQUIRED TO MEET OR EXCEED ALL TESTS PROVISIONS OF THE MOST CURRENT ANSI/SCIE 77-2007 "SPECIFICATIONS FOR UNDERGROUND INTEGRITY" FOR TIER 15 OR BETTER.

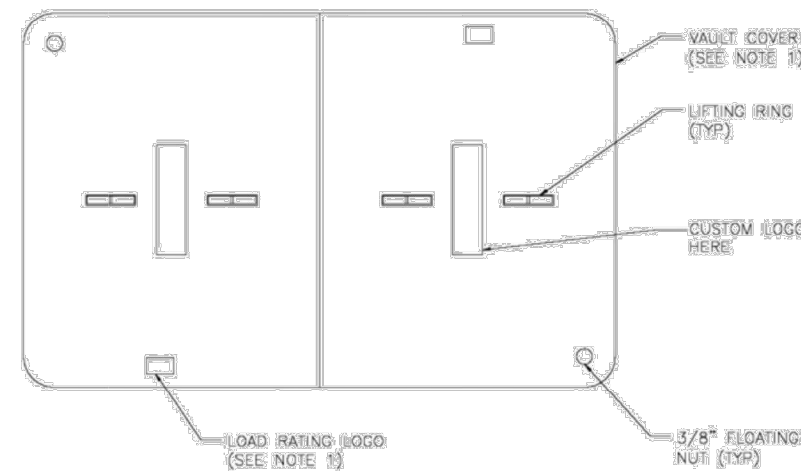
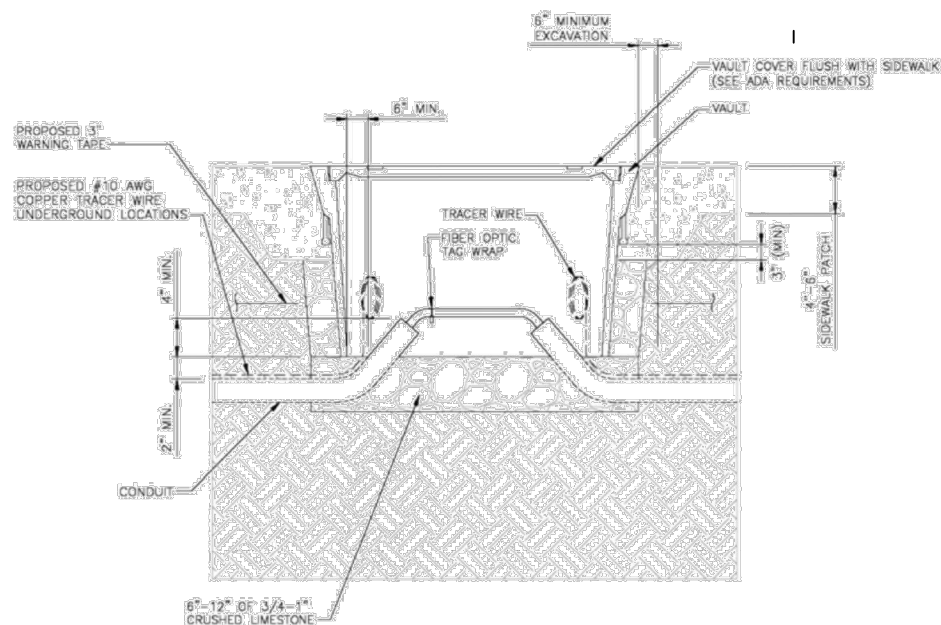

**PEDESTRIAN ACCESS ROUTE**

**VAULT W/ BOTTOM ENTRY**

**VAULT LID**

REV	DATE	DESCRIPTION	BY
A	??/??/??	90% REVIEW	??

I HEREBY CERTIFY THAT THESE DRAWINGS WERE PREPARED BY ME OR UNDER MY DIRECT SUPERVISION AND CONTROL, AND TO THE BEST OF MY KNOWLEDGE AND BELIEF COMPLY WITH THE REQUIREMENTS OF ALL APPLICABLE CODES.

TASK NAME	07758.MX
TASK DESCRIPTION	1300 PINE ST
PROJECT AREA	LaCrosse, WI, USA
SHEET SCALE	N.T.S.
SHEET TITLE	DETAILS
GRID NUMBER	
SHEET NUMBER	D-6