

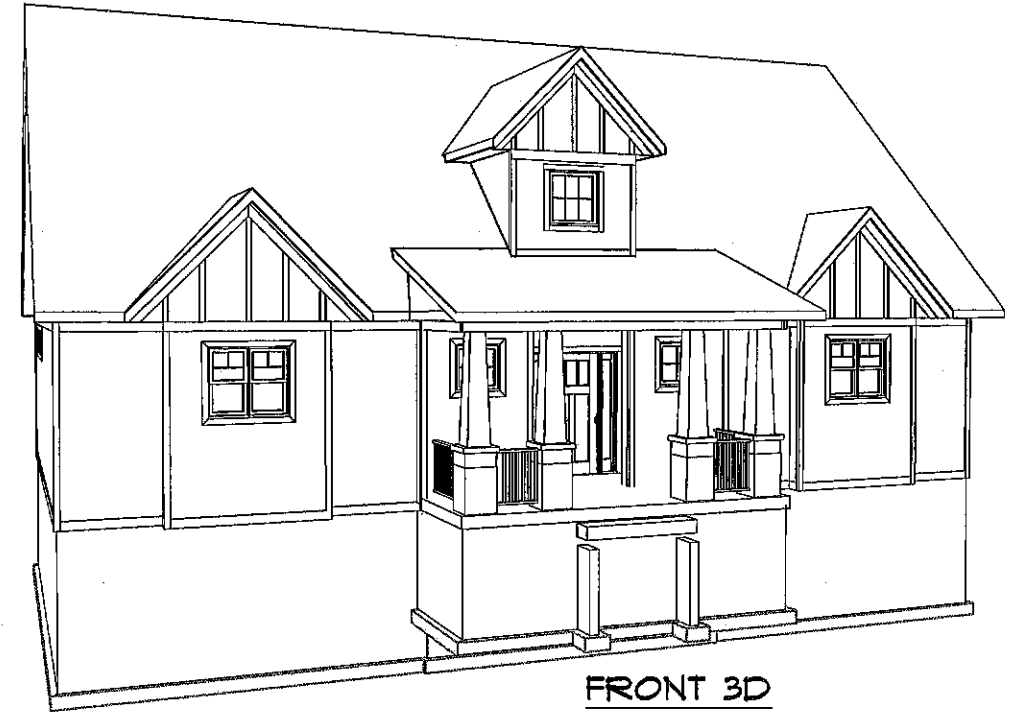

**FRONT**



**FRONT 3D**



**BACK**

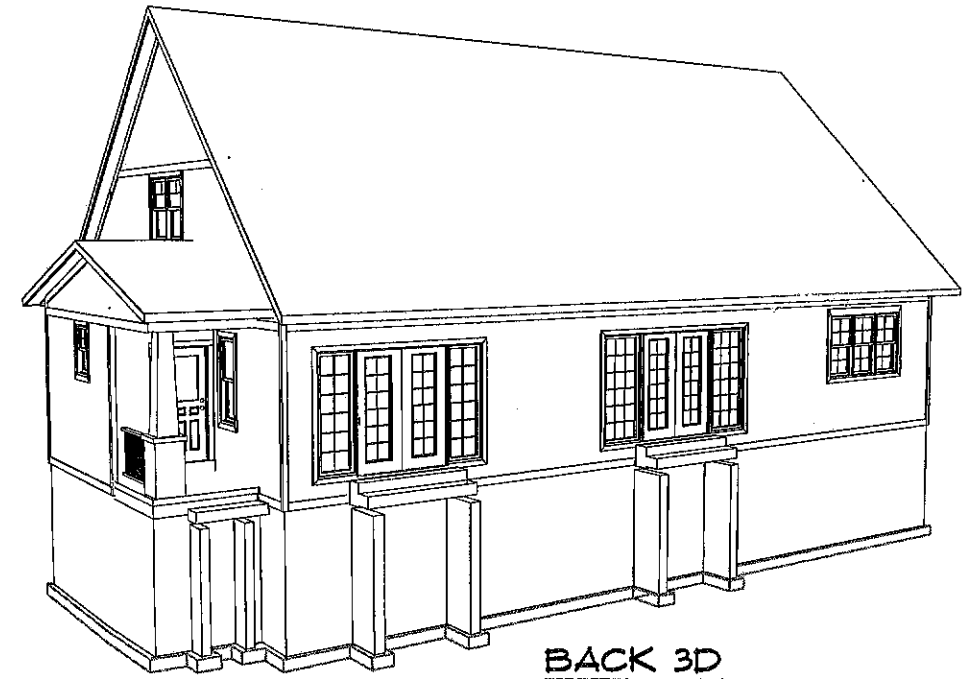

**BACK 3D**

**PRELIMINARY**

NAME	AREA
MAIN LEVEL	1828 sq. ft.
UPPER LEVEL	940 sq. ft.
GARAGE	624 sq. ft.
BASEMENT FIN.	388 sq. ft.
BASEMENT UNFIN.	1448 sq. ft.

**MasterCraft**  
Confidence Builders HOMES

MASTERCRAFT HOMES INC.  
2900 OAK ST.  
LA CROSSE, WI 54603  
PHONE: 608-781-7200 FAX: 608-781-7207  
EMAIL: INFO@MCH-LAX.COM

SCOTT MARY RATHGABER  
LA CROSSE WI

SCALE:  
1/8" = 1'-0"

DATE:  
Friday, November 21, 2008

DRAWN BY: K.R.

CONTRACT M-

SHEET #

**A-2**

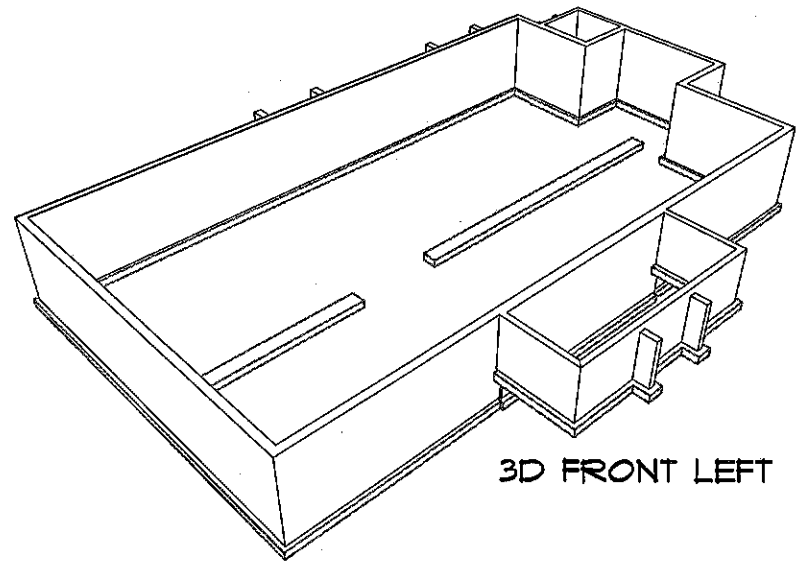
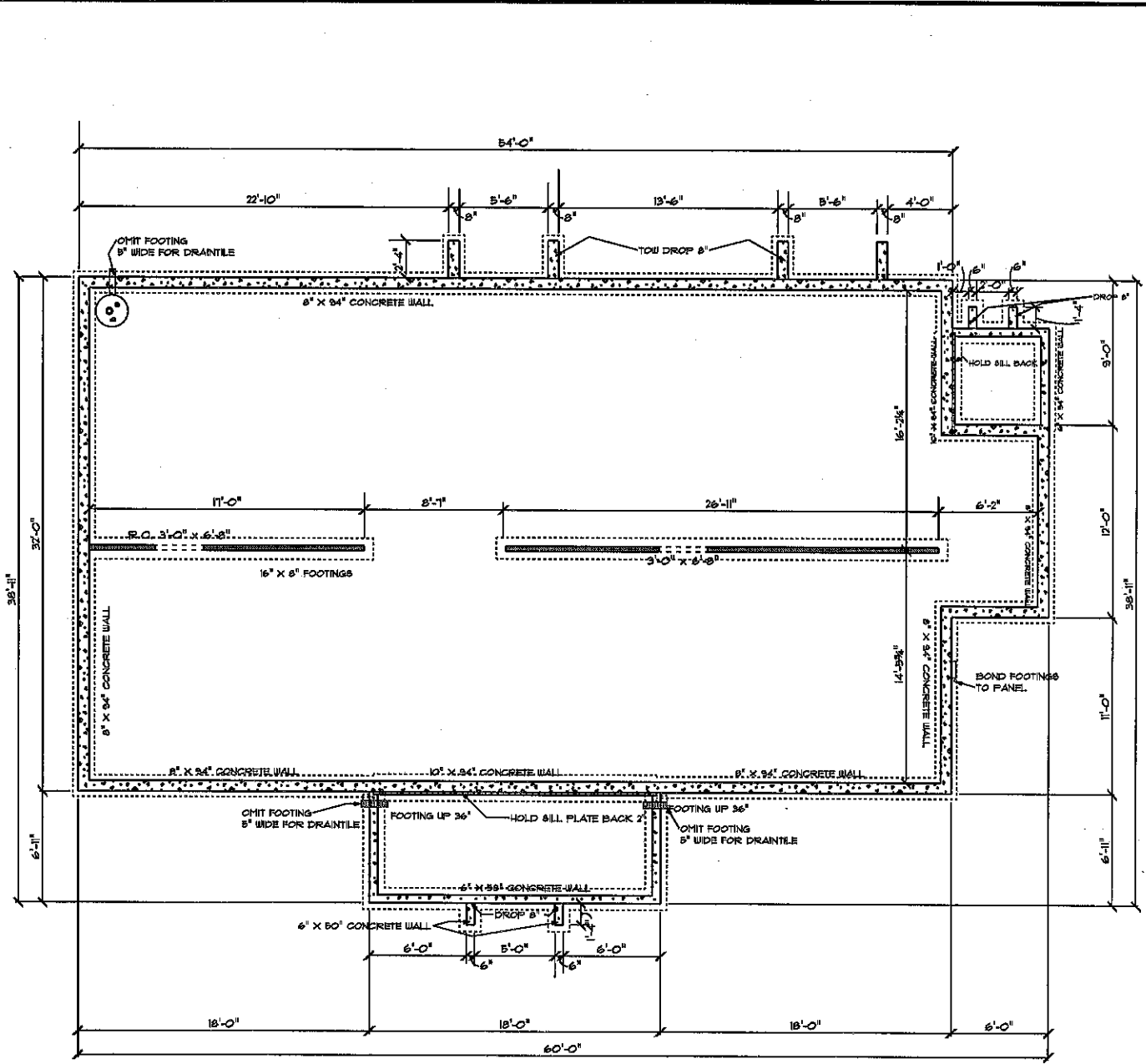

3D FRONT LEFT

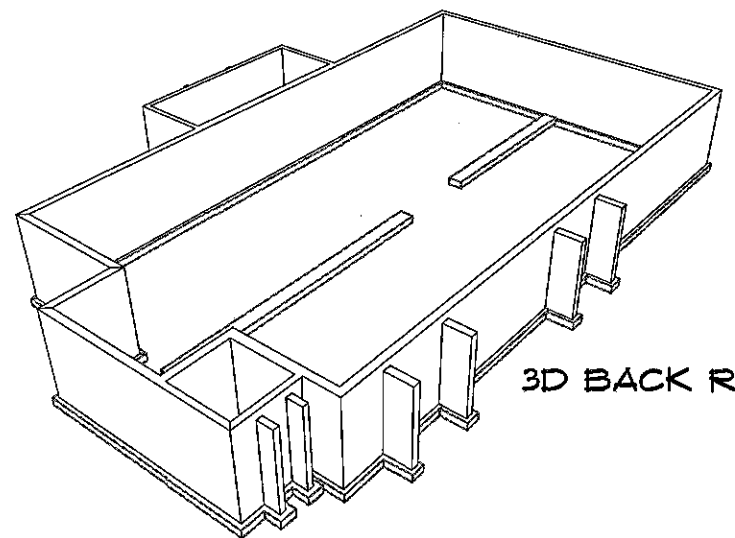

3D BACK RIGHT

PRELIMINARY

GROUND WIRE FOR SERVICE PANEL MUST BE RUN TO REBAR IN FOOTINGS. CALL WALCKER ELECTRIC 608-397-0278 BEFORE FOOTINGS ARE POURED.

NAME	AREA
MAIN LEVEL	1828 sq. ft.
UPPER LEVEL	940 sq. ft.
GARAGE	624 sq. ft.
BASEMENT FIN.	388 sq. ft.
BASEMENT UNFIN.	1448 sq. ft.

**MasterCraft**  
Confidence Builders HOMES

MASTERCRAFT HOMES INC.  
2500 OAK ST.  
LA CROSSE WI 54603  
PHONE: 608-781-7000 FAX: 608-781-7077  
EMAIL: INFO@MCHLAX.COM

SCOTT MARY RATHGABER

LA CROSSE WI

SCALE:  
1" = 10'  
DATE:  
Friday, November 21, 2008  
DRAWN BY: K.R.  
CONTRACT N-

SHEET •  
**A-4**





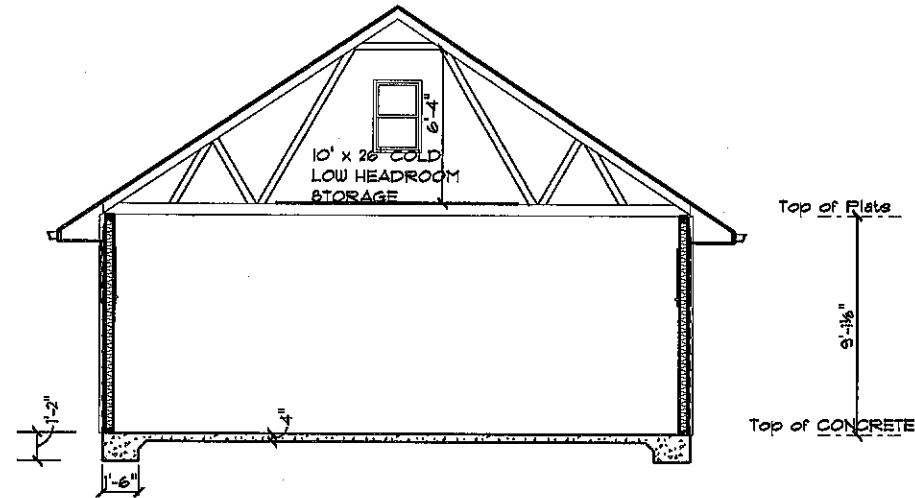
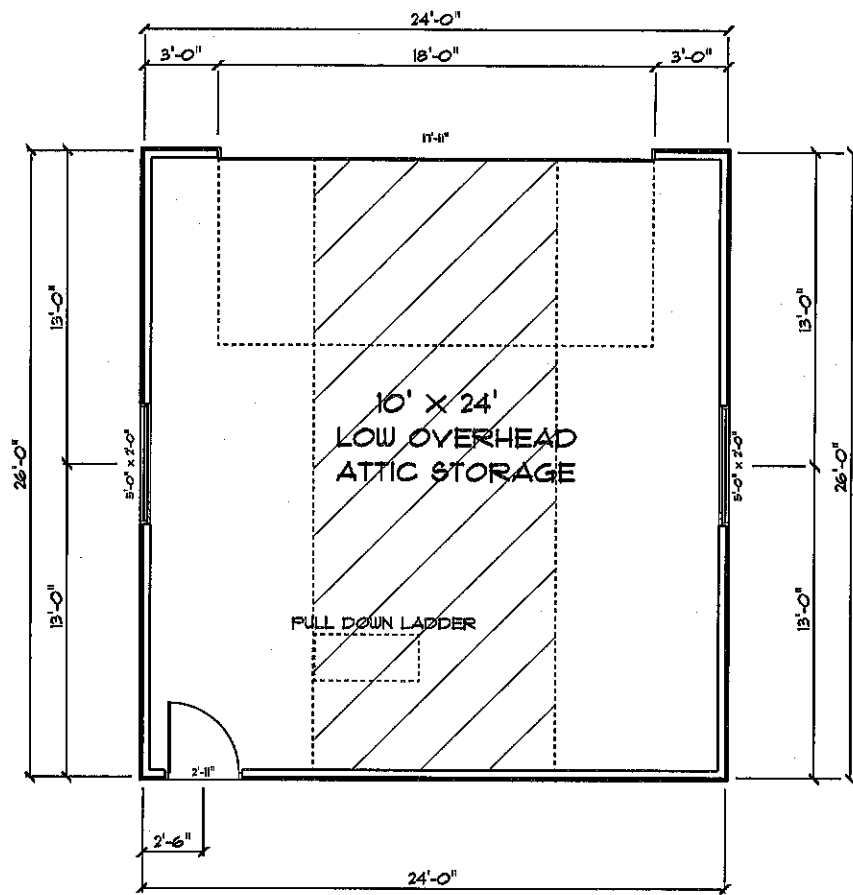

X SECTION

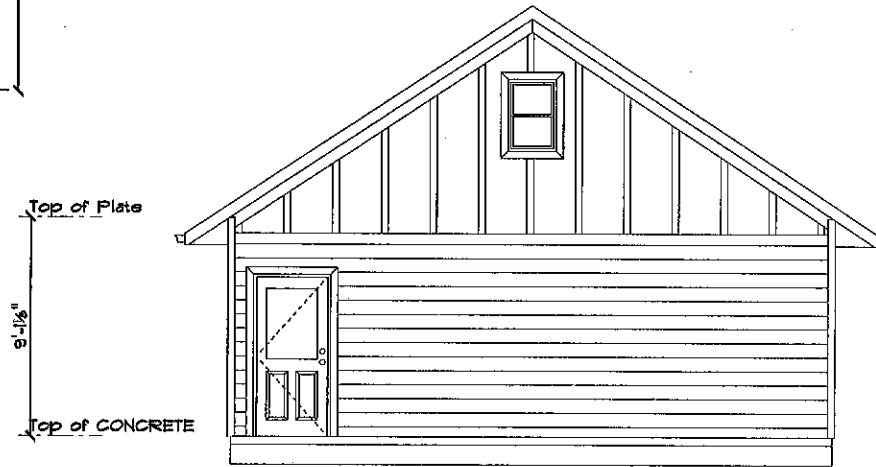

FRONT TO HOUSE

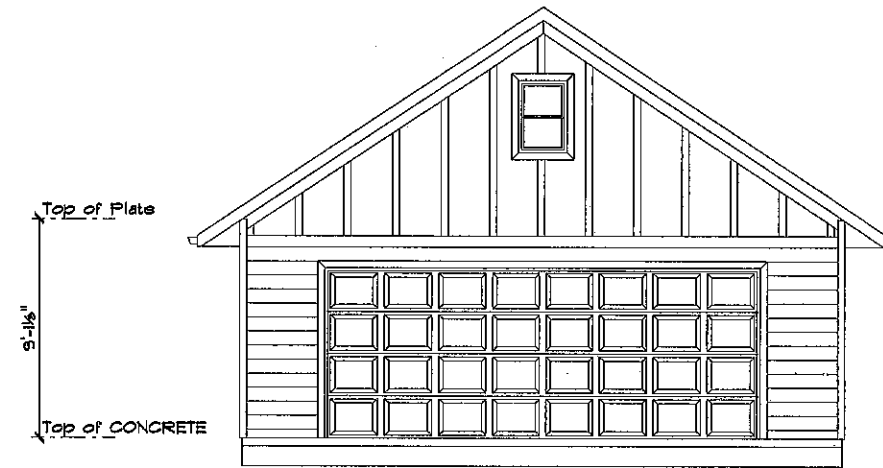

BACK TO ALLEY

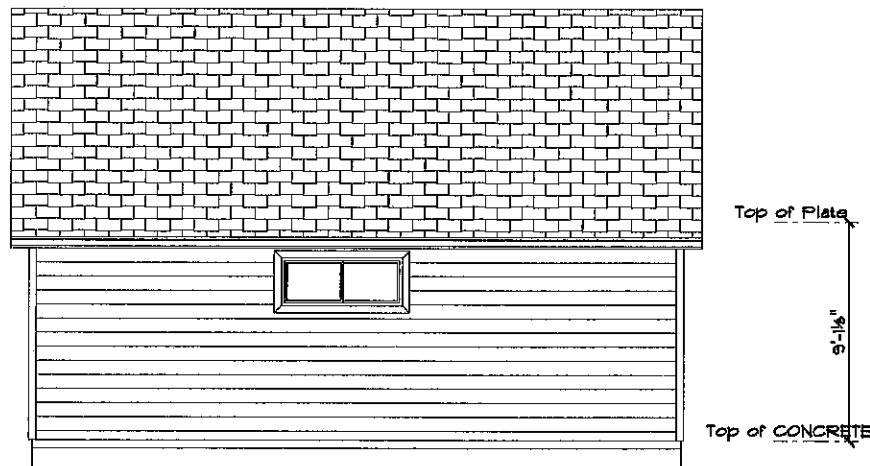

LEFT  
PRELIMINARY



RIGHT

NAME	AREA
MAIN LEVEL	1828 sq. ft.
UPPER LEVEL	940 sq. ft.
GARAGE	624 sq. ft.
BASEMENT FIN.	388 sq. ft.
BASEMENT UNFIN.	1448 sq. ft.