

DEVIATION FROM PLANS – Any deviation from these plans shall have been consulted with and documented by the supervising professional.

NON-CONTRACT ITEMS – Items may appear on these plans that are done by others and are not part of the Walters Buildings' contract.

WALTERS BUILDINGS GENERAL SPECIFICATIONS

SPLASHBOARDS – Splashboards are 2"x4" S4S #2 or better Southern Pine, pressure treated to a net retention of 0.4 pounds per cubic foot with Smart Sense™ copper based treatment.

Building code compliant – NER #628. One row is furnished for building on a level grade. Smart Sense™ is a trademark of S-T-N Holdings, Inc.

FRAMING – Side girts are 2"x4" S4S 1650 MSR or better Spruce Pine Fir spaced approximately 32" o.c. with all joints staggered at attachment to columns. Roof purlins are 2"x6" S4S 2400 MSR or better Southern Yellow Pine spaced on edge approximately 24" o.c.

GUTTERS – 5" box type gutters, color to match trim, on both side of the building.

ROOFING PANELS – Structural Steel Grade 80 with G-90 Sheet, pretreatment, urethane primer, and Modified silicon polyester topcoat. Conforms to ASTM A 653.

SIDING PANELS – Structural Steel Grade 80 with G-90 Sheet, pretreatment, urethane primer, and Modified silicon polyester topcoat. Conforms to ASTM A 653.

TRIM – Die formed trim of Structural Steel Grade 80 with G-90 Sheet, pretreatment, urethane primer, and Modified silicon polyester topcoat on gables, ridges, corners, base, windows and doors.

ERECTION NOTES – All wood members must be properly braced until the complete structural system has been completed. The contractor must refer to TPI publication BCSI-B10 POST FRAME SUMMARY SHEET, "POST FRAME TRUSS INSTALLATION & TEMPORARY RESTRAINT / BRACING" for erection, handling and bracing guidance.

SITE WORK – The building site shall be graded to provide drainage away from the building. Maintain the grade levels shown on the plan around the building.

STRUCTURAL STEEL – All structural steel required shall be equal to A-36. Design shall conform to the latest AISC Specifications.

WOOD – All wood design shall conform to ANSI/AF&PA NDS-2015.

SOIL BEARING VALUES – Foundations shall not be placed prior to confirmation of the soil type at a depth of 5 feet below the bottom of the footing. The presumed soil bearing value for footing design is 2,000 PSF.

PLACEMENT – All below grade concrete or Sakrete footings to bear on firm, dry, virgin soil or compacted granular fill in uniform layers not exceeding 8" in depth after compaction. Each layer shall be uniformly spread and compacted at the optimum moisture content to a dry density that is at least 90% of the maximum density.

CONCRETE – Design mixes shall be obtained from the following: 1. Strength to be a minimum of 3500 PSI at 28 days for walls and footings. 2. Strength to be a minimum of 3500 PSI at 28 days for floor slabs. 3. Slump not to exceed 4 inches. Concrete placement shall be in accordance with ACI 318-95. * CONCRETE SLUMP TEST RESULTS REPORT WILL BE PROVIDED. ** Visual soil bearing composition will be performed and to meet the min. bearing capacity of 2000 psf.

REINFORCING STEEL – Steel reinforcing shall meet the requirements of the "Standard Specifications" for:

- 1. Billet-Steel Concrete Reinforcing Bars Grade 60 (ASTM designation A-615).
2. All steel bars shall meet the requirements of ASTM designation A-615. All welded wire mesh
3. for concrete reinforcement shall meet the requirement shall meet the requirements set forth in
4. Standard Specification (ASTM designation A-185). The reinforcement shall not be painted and
5. must be free from grease, dirt or deep rust when placed in the work. To prevent rust, the material
6. must be protected from moisture. The reinforcement shall be protected by the proper thickness of
7. concrete. Where not otherwise shown, the thickness of concrete over the reinforcement shall be :
A. Where concrete is deposited against the ground without the use of forms, the thickness of
B. concrete shall not be less than 3 inches.
C. Where concrete is exposed to weather, the thickness of concrete shall not be less than 1 1/2 inches.
D. In columns or pedestals not exposed to weather or ground, the thickness of concrete shall not be
E. less than 1 1/2 inches.
Reinforcing steel shall be placed in accordance with CRSI Standards.

ANCHOR BOLTS – The contractor shall set all anchor bolts to receive the building. The bolts shall be the size as shown or required and shall be set with the use of a template. They may be drilled into place as allowed. The anchor bolts must be set or drilled into concrete with a minimum strength of 3,000 PSI at 28 days. Many states require a #2 bolt with a minimum of 7" embedment.

EXIT SIGN – Sign shall have an illumination intensity of not less than 5 foot-candles. Exit signs shall be illuminated at all times. To ensure continued illumination for a duration of not less than 90 minutes in case of primary power loss. Per IBC 1003.2.10.1, exit signs are not required in rooms or areas which require only one exit. Provide an approved type illuminated sign bearing the word "EXIT" in 6" high letters above all doors shown as a circled letter "E" with four radiated dashes.

Check required door & window rough openings before framing.

WALK DOORS – Solid Blank Polyurethane Foam Core or With Double Pane Window. WINDOWS – Double Pane Clear Thermal Break Metal Frame Windows. OVERHEAD DOORS – Thermal Core.

ELECTRICAL – All work shall be done in strict accordance with state and local codes. Electrical work in not part of this plan

Exterior cracks, joints, and holes in the buildings envelope are caulked, gasketed, weatherstripped, or otherwise sealed. Interior finish of walls & ceiling shall have a flame spread rating of less than 200. Interior finish Class III Rating – flame spread rating less than 200 and smoke development rating of less than 450.

SOUND & INSULATION – Exposed shall have a flame spread rating of 25 or less and smoke development rating of 450 or less. Concealed shall have a flame spread rating of 75 or less and a smoke development rating of 450 or less. Vapor retarder shall be installed to the warm side of the insulation.

GENERAL SPECIFICATIONS

The project consists of a Studwall structure for SUSAN A. BUTE, FINISH LINE STORAGE per WALTERS BUILDINGS Specifications. The building is a total of (6,193) sq. ft.

BUILDING LOCATION : FINISH LINE STORAGE
2110 ENTERPRISE AVE
LA CROSSE, WI
LA CROSSE COUNTY

Type of Construction – 5B, Unprotected Combustible
Use Group Classification – S-1 – MODERATE HAZARD STORAGE
NON-HEATED MINI STORAGE STUDWALL BUILDING

2015 IBC

S-1 MODERATE HAZARD STORAGE – Risk Category II
Tabular Allowable Area per IBC Table 506.2 = 9,000 sq. ft.
Total Allowable Area Based on Open Perimeter & Sprinkler Requirements = 12,000 sq. ft.
Allowable Height per IBC Tables 504.3 & 504.4 = 1 Story, 40 feet

OCCUPANT LOAD – Risk Category II
(AREA 1) = 6193 sq. ft./500 = 13.39
ACTUAL OCCUPANT LOAD = 13
LARGEST UNIT OCCUPANCY = 1

SNOW – Risk Category II
Pf = 0.7CeCtIpg
Ps = CsPf
Pg (Ground Snow Load) = 40 PSF
Ce (Snow Exposure Factor) = 1.0
Ct (Thermal Factor) = 1.2
I (Snow Load Importance Factor) = 1.0
Pf (Flat Roof Snow Load) = 33.6 PSF
Cs = 0.94
Ps = 31.5 PSF
Unbalanced Snow Load = 35 PSF USING SPS 362.1608
Used Design Roof Snow Load = 35 PSF

WIND – Risk Category II
Qz = 0.00256KzKztKd(V)2
P = Qz[(GCpf)-(GCpi)]
Kz (Velocity Pressure Exposure Coefficient) = 0.70
Kzt (Wind Speed Up) = 1.0
Kd (Wind Directionality) = 0.85
U (ULTIMATE WIND SPEED) = 115 MPH
Nominal Wind Speed Conversion Factor = 0.6
V (Nominal Wind Speed) = 89.1 MPH
I (Wind Load Importance Factor) = 1.00
Qz (Velocity Pressure) = 12.1 PSF
GCpf = Figure 6-3
GCpi = +0.18 or -0.18
USED P = 13 PSF
Exposure Category B = Represents urban and suburban, wooded areas or terrain with numerous closely spaced obstructions the size of single family dwellings or larger.

SEISMIC – Risk Category II
Ss (Mapped Spectral Response Acceleration 0.2 Sec) = 5.30%
S1 (Mapped Spectral Response Acceleration 1.0 Sec) = 3.60%
Sds (Spectral Response Coefficient) = 0.057
SD1 (Spectral Response Coefficient) = 0.058
Seismic Design Category = Category A
Site Class D
Seismic Base Shear = 1,357#
Basic Structural and Seismic-Resisting System= Light Framed Walls W/Shear Panels

R (Response Modification Factor) = 7.0
Cs (Seismic Response Coefficient) = 0.010
Using Equivalent Lateral Force Procedure

LOADS
Ground Snow Load : 40 PSF
Design Snow Load (Ps = Live Load) : 31.5 PSF
Unbalanced Snow Load = 35 PSF
Snow Load Used= 35 PSF
Total Load Used= 39 PSF
115 MPH Exposure B
Design Wind Load (P=Velocity Pressure): 13 PSF
Presumed Soil Bearing Capacity : 2000 PSF
Presumed Lateral Soil Pressure : 150 PSF

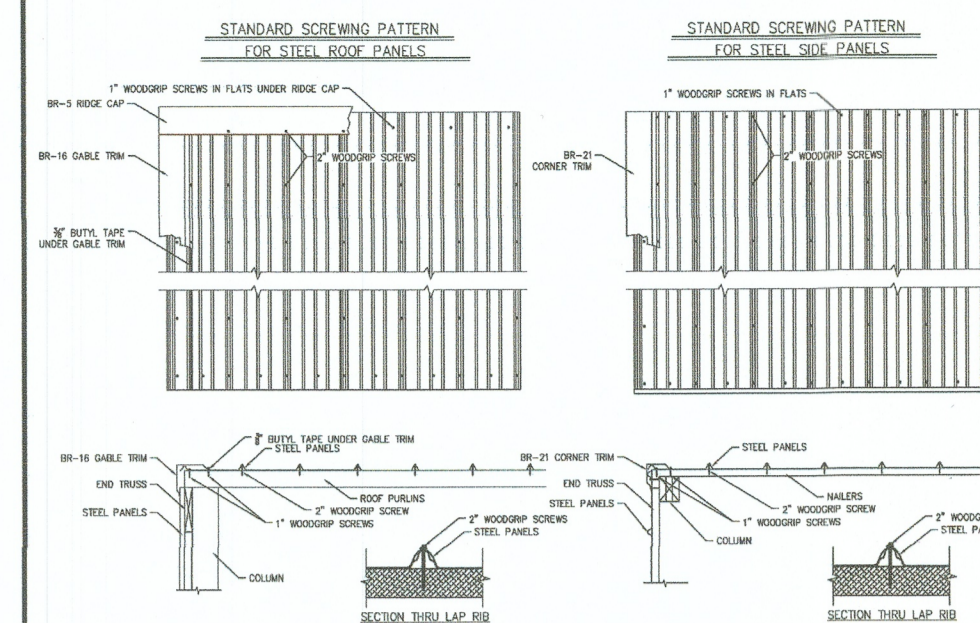

ABBREVIATIONS table listing various construction abbreviations and their full names. Includes terms like ASB, AFF, ASPH, BD, BWP, BIT, BLK(G), BDI, BRG, B.S., C, CFT, C.H., CLOS, COM, C.M.U., d, DBL, E.C., E.E., E.F., E.W., F.D., F.E., F.O., FT, GA, GTE, GTH, IN, LAM, L.V., LVR, MAS, MIL, M.O., M.W., N.B.W., N.I.C., N.T.S., O.C., OHD, O/O, PERI, PL, PSF, PSI, P.T., R.C., R.O., R.O.W., S.C., S.O.G., S.T.P., T&G, T.O.L., T.O.W., TYP, TRED, U.O.N., WH, WWP, Latory, Lower Masonry, Millimeter(s), Masonry Opening, Not By Walters Buildings, Not In Contract, Not To Scale, On Center(s), Overhead Door, Out. to Out, Perimeter, Property Line, Pounds per Square Foot, Pounds per Square Inch, Pressure Treated, Raised Chord, Rough Opening, Right of Way, Straight Chord, Slab on Grade, Square, Steel Transfer Plate, Tongue & Groove, Top of Ledger, Top of Wall, Typical(y), Treated, Unless Otherwise Noted, Water Heater, Welded Wire Fabric.

FASTENING SCHEDULE table with columns: BUILDING ELEMENT, NAIL OR STAPLE SIZE & TYPE, NUMBER & LOCATION. Lists fastening requirements for various elements like floor construction, wall construction, roof & ceiling construction, etc.

Note A: Single nails shall penetrate not less than 3/4" into nailing strips, sheathing or supporting construction except as otherwise provided for in Section 1507.0.
Note B: For regions having a basic wind speed of 90 mph or greater where the main roof height is less than 25 ft. and for regions having basic wind speed of 80 mph or less, nails which attach wood structural panel roof sheathing to gable end wall framing shall be spaced 6" o.c. Where basic wind speed is greater than 80 mph, nails which attach panel roof sheathing to intermediate supports shall be spaced 6" o.c. of a minimum of a 48" distance from ridges, eaves & gable end walls; & 4" o.c. to gable end wall framing.
Note C: For regions having a basic wind speed of 90 mph or greater, 8d deformed shank nails shall be utilized to attach wood structural panel roof sheathing to framing within a minimum 48" distance from gable end walls provided the mean roof height is between 25' and 35'. For roof heights greater than 35' in a 90 mph or greater wind region, attachment of wood structural panel roof sheathing shall be designed for the wind loads in Section 1609.0.
Note D: Nails shall be spaced 6" o.c. direct to panel edges and 6" o.c. to intermediate supports where panel spans are 48" o.c. or greater.
Note E: 1" = 25.4mm, 1' = 304.8mm.

SHEET INDEX table listing sheet numbers and corresponding specifications or drawings. A1 - SPECS PAGE, A2 - ELEVATIONS, A3 - FRAMING/CONCRETE PLAN, A4 - SECTIONS, A5 - SECTIONS, A6 - DETAILS, P1 - PLOT PLAN



Walters Buildings logo and contact information: Jack Walters & Sons Corp., P.O. Box 388, 6600 Midland Ct., Allendale, WI 53002, 1-800-558-7830, www.waltersbuildings.com. Includes a REVISIONS table, OWNER information (SUSAN A. BUTE), PROJECT information (FINISH LINE SELF STORAGE), LOCATION (2110 ENTERPRISE AVE, LA CROSSE, WI), SALES REP / DEALER (DAVE RUDRUD), DRAWN BY (JOHN S. ON 10/9/2019), ESTIMATED BY (EST ON), LAST SAVED BY (JSCHEIDER ON 10/9/2019), JOB NUMBER (P98-1153R3), SHEET NUMBER (A1), and a graphical scale bar (1/8" = 1'-0").

DOOR & UNIT SCHEDULE		
TAG	TYPE	QTY
①	9'-0"x7'-0" ROLL UP DOOR	34
②	3'-0"x6'-8" COMMERCIAL WALKDOOR w/ KIKKSET LEVERSET	4
A	10'x30' UNIT	3
B	10'x20' UNIT	28

REVISIONS:

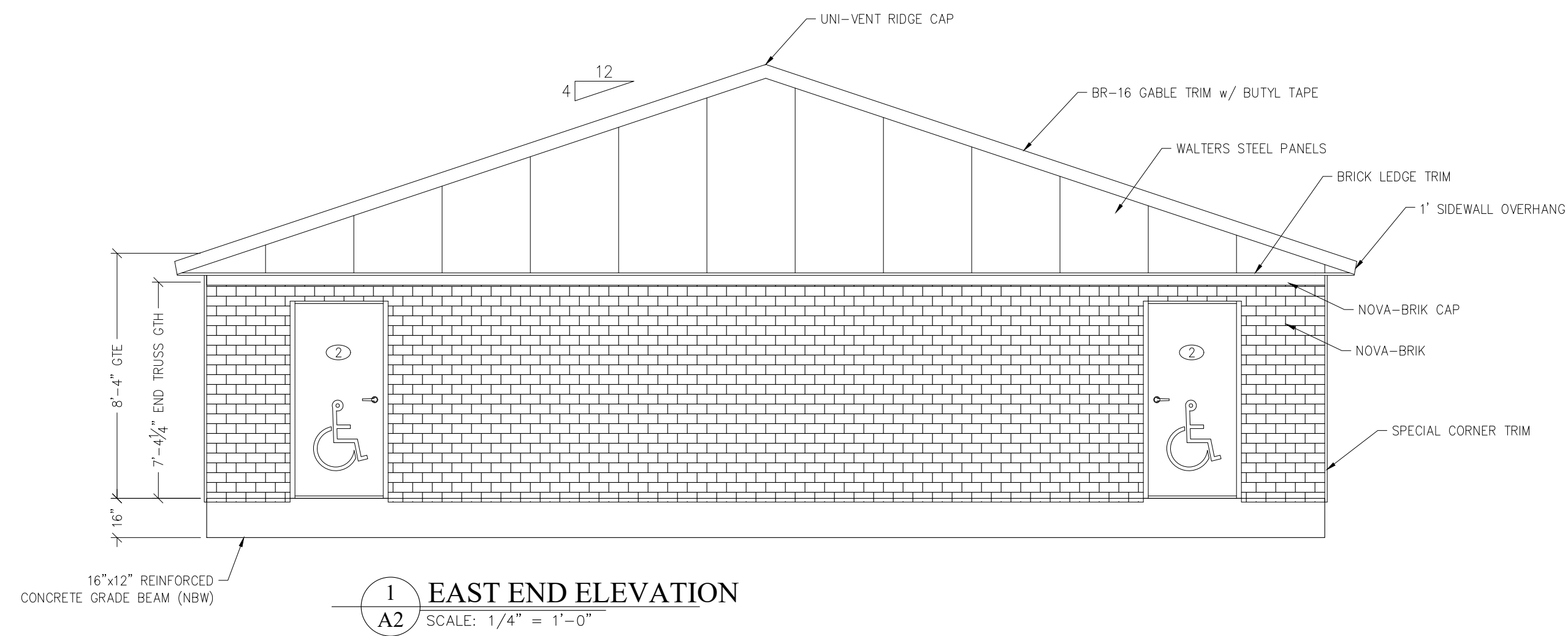

1 EAST END ELEVATION
 A2 SCALE: 1/4" = 1'-0"

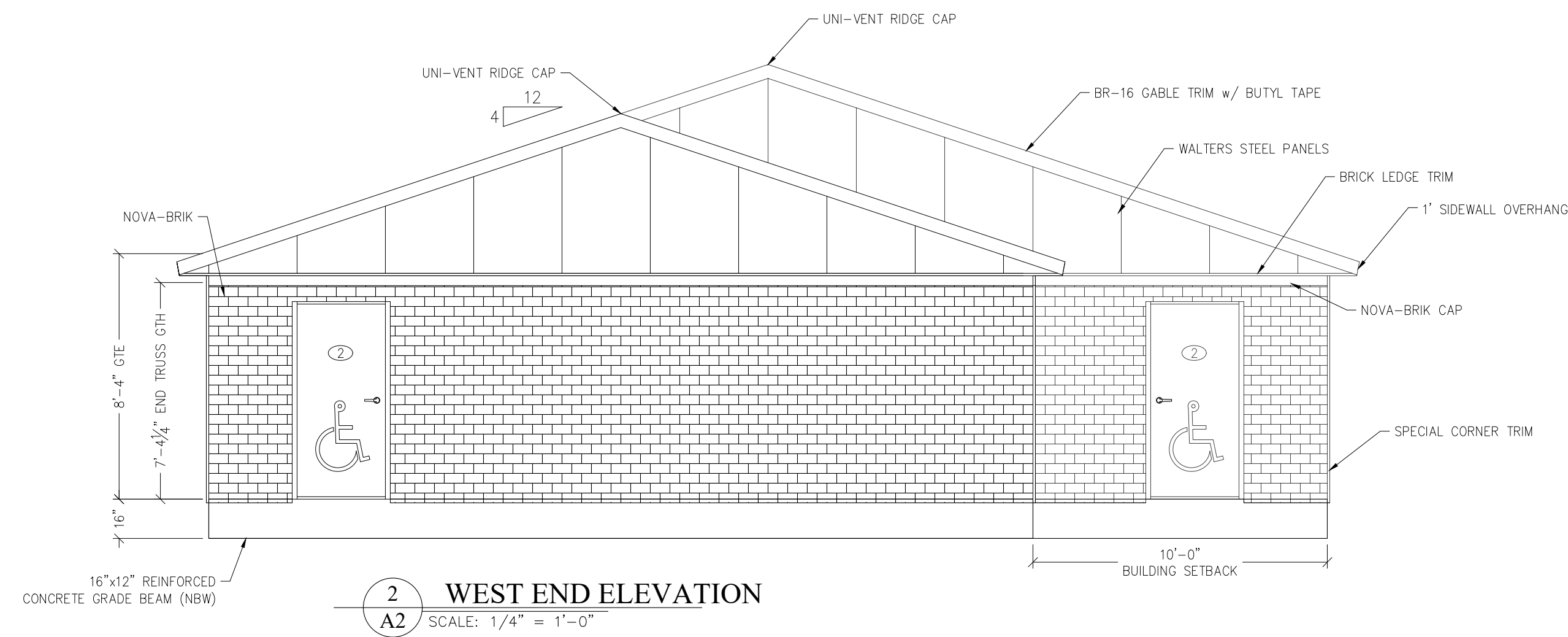

2 WEST END ELEVATION
 A2 SCALE: 1/4" = 1'-0"

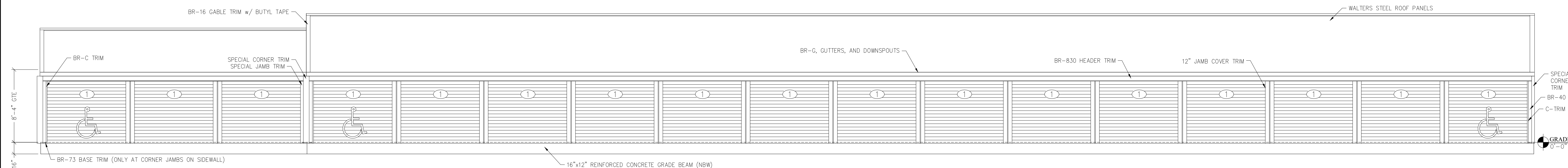

3 SOUTH SIDE ELEVATION
 A2 SCALE: 3/16" = 1'-0"

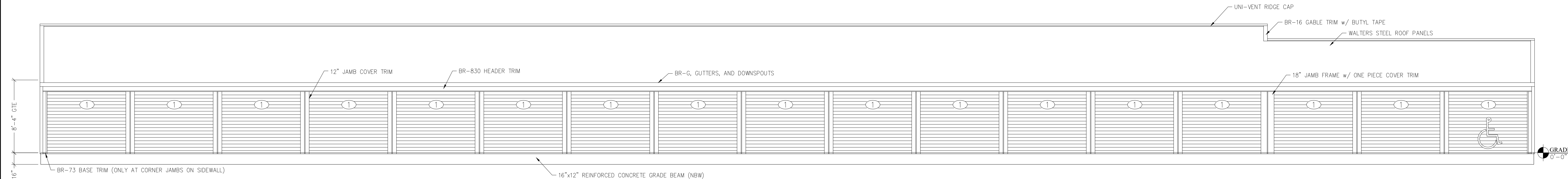

4 NORTH SIDE ELEVATION
 A2 SCALE: 3/16" = 1'-0"

OWNER:
 SUSAN A. BUTE

PROJECT:
 FINISH LINE
 SELF STORAGE

LOCATION:
 2110 ENTERPRISE AV.
 LA CROSSE, WI

SALES REP / DEALER:
 DAVE RUDRUD

DRAWN BY:
 JOHN S. ON: 10/10/2019

ESTIMATED BY:
 EST ON:

LAST SAVED BY:
 JSCHNEIDER ON: 10/10/2019

SCALE:
 AS NOTED

JOB NUMBER:
 P98-1153R3

SHEET NUMBER:

DOOR & UNIT SCHEDULE

TAG	TYPE	QTY
①	9'-0"x7'-0" ROLL UP DOOR	34
②	3'-0"x6'-8" COMMERCIAL WALKDOOR w/ KWKSET LEVERSET	4
A	10'x30' UNIT	3
B	10'x20' UNIT	28



ACCESSIBLE UNITS - Per IBC 1107.6 at least 5% of mini-storage units with a minimum of one of each size, shall be accessible. Per IBC 1003.3.1.6 slope concrete at accessible units so as to provide a doorway threshold of 1/2" or less. Raised thresholds shall be beveled with a slope no greater than 1:21. Accessible storage units shall have permanent accessibility identification per IBC 1101.2 (ANSI) A117.1 703.1 & 703.2. A storage space is considered accessible if there is any one of the following: 1) a swing door with a minimum of 32" clearance and 6'-8" height; 2) an electric garage door opener installed for use with an overhead door; or 3) the roll up door meets the opening & closing force maximums of IBC 1008.1.2 and has accessible hardware.

FIRE EXTINGUISHERS - OWNER TO FURNISH AND INSTALL FIRE EXTINGUISHERS PER NFPA NO. 10

Hazard Occupancy	NFPA TABLE 3-2.1		
	Light Duty	Ordinary (Moderate)	Extra (High)
Minimum Rated Single Extinguisher	2-A	2-A	4-A
Minimum Floor Area per Unit of A	3,000 sq. ft.	1,200 sq. ft.	1,000 sq. ft.
Minimum Floor Area per Extinguisher	11,250 sq. ft.	11,250 sq. ft.	11,250 sq. ft.
Minimum Travel Distance to Extinguisher	75 ft.	75 ft.	75 ft.

• Two 2 1/2 Gallon Water Type Extinguishers can be used to fulfill the requirements of One 4-A Rated Extinguisher.

*6 MIL UNDER SLAB VAPOR RETARDER WITH JOINTS LAPPED NOT LESS THAN 6" IS REQUIRED EXCEPT FOR:

- UNHEATED BUILDINGS
- UNHEATED STORAGE ROOMS LESS THAN 20 SQUARE FEET & CARPORTS ATTACHED TO R-3 OCCUPANCIES
- FOR BUILDINGS OF OTHER OCCUPANCIES WHERE MIGRATION OF MOISTURE THROUGH THE SLAB FROM BELOW WILL NOT BE DETRIMENTAL TO THE INTENDED OCCUPANCY OF THE BUILDING
- FOR DRIVEWAYS, WALKS, PATIOS & OTHER FLATWORK THAT WILL NOT BE ENCLOSED AT A LATER DATE
- WHERE APPROVED BASED ON LOCAL SITE CONDITIONS

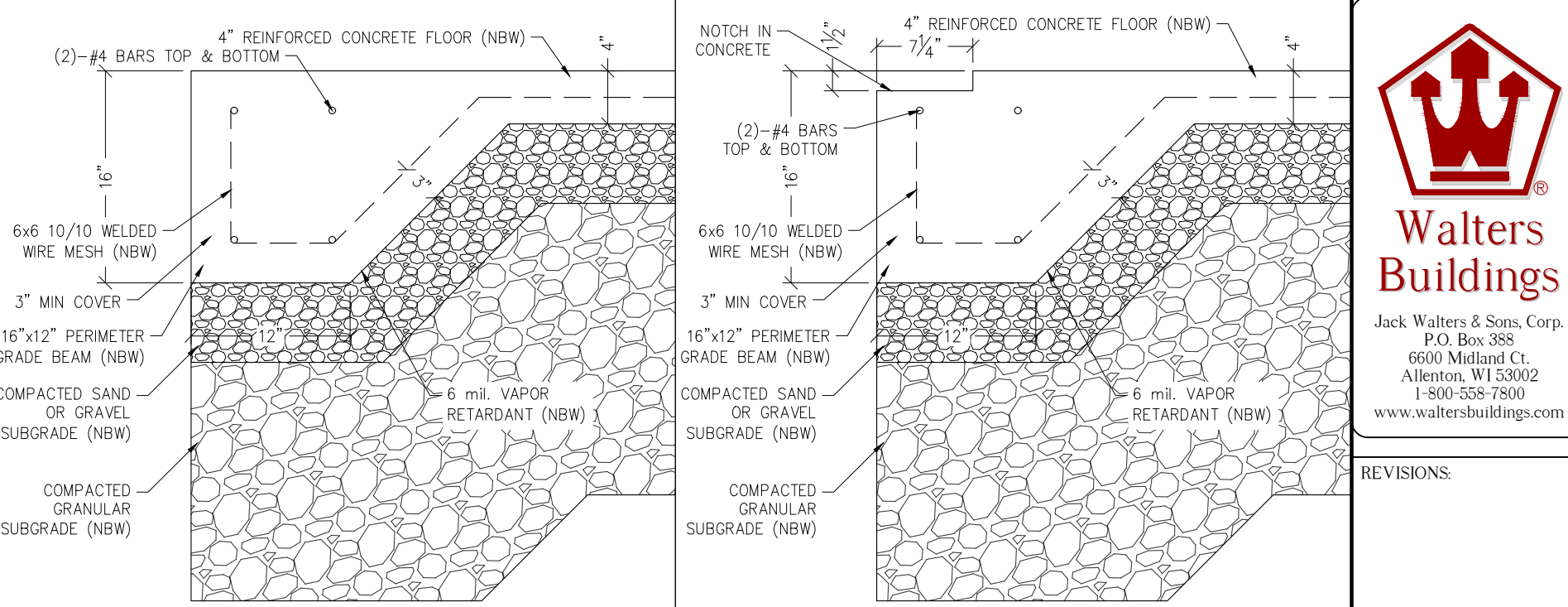

1 CONCRETE DETAIL
SCALE: 1" = 1'-0"

2 CONCRETE NOTCH
SCALE: 1" = 1'-0"

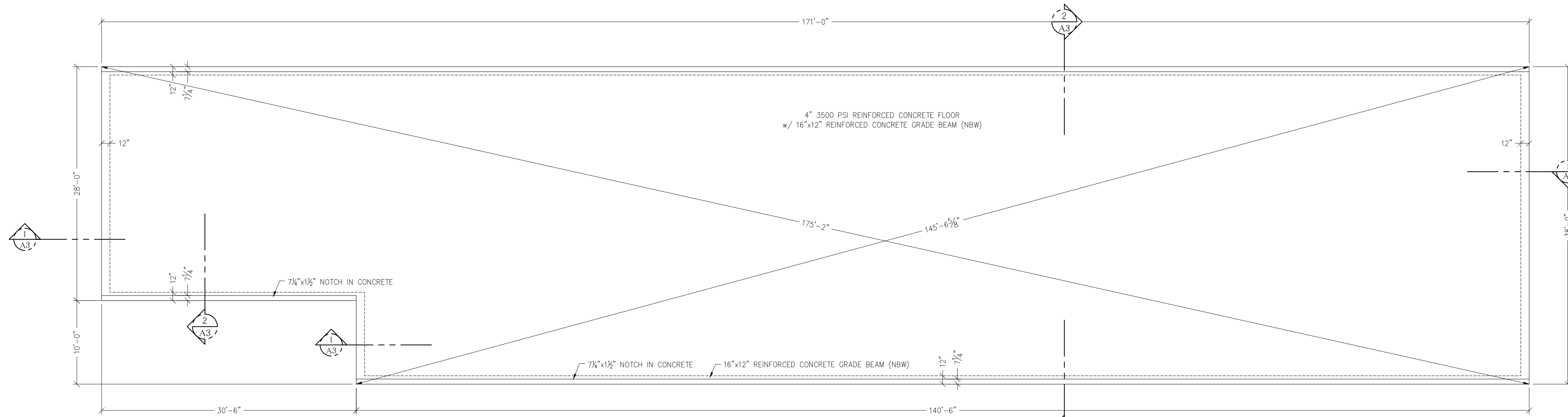

1 CONCRETE PLAN
SCALE: 1/8" = 1'-0"

The Rawl-Stud is available with a length identification mark stamped on the head of the anchor as shown below.

Mark	A	B	C	D	E	F	G	H
From	1 1/2	2	2 1/2	3	3 1/2	4	4 1/2	5
Up to But Not Including	2	2 1/2	3	3 1/2	4	4 1/2	5	5 1/2

Mark	I	J	K	L	M	N	O	P
From	5 1/2	6	6 1/2	7	7 1/2	8	8 1/2	9
Up to But Not Including	6	6 1/2	7	7 1/2	8	8 1/2	9	9 1/2

Mark	Q	R	S	T	U	V	W	X	Y	Z
From	9 1/2	10	11	12	13	14	15	16	17	18
Up to But Not Including	10	11	12	13	14	15	16	17	18	19

The dependable holding power of the Rawl-Stud makes this anchor ideal for heavy construction applications such as bridges, dams, and power plants. It is particularly well suited for fastening highway guard railings and signs, mechanical supports, elevator equipment, conveyors, machinery storage racks, loading docks, railings, and floor and window framing.

The Rawl-Stud is ideal for fastening angle brackets, support angles for floors and formwork, and high-load shelving.

Using the Rawl-Stud, supports for highway and commercial signs are securely attached to a wide variety of masonry materials.

The Rawl-Stud is a one-piece anchor available in carbon steel or stainless steel for installation in highly corrosive environments.

The patented dual inter-locking expansion wedges provide optimum performance. During installation of the Rawl-Stud, the interlocking tabs on the wedges prevent spinning of the anchor during the tightening process. As the anchor is tightened, the wedges distribute the compression load equally in lateral planes to prevent cocking of the anchor or premature failure of the concrete due to uneven distribution of the load.

Supports for piping, conduits, and electrical junction boxes are securely fastened with the Rawl-Stud.

The one-piece Rawl-Stud is ideal for the installation of equipment such as elevator guide rails.

⊠ = DENOTES 2x6 1650 MSR SPF LEDGER BOARD SIDE

Use in: Concrete, stone
Use with: No other fastener needed
Made of: Carbon steel or stainless steel
Size range: 1/4" x 1-3/4" to 1-1/4" x 12"
No layout or hole spotting required
Patented inter-locking wedges
FM approved, UL listed,
ICBO Report No. 4514, Metro-Dade
89 diameters and lengths, other
sizes on special order
Also stocked in mechanically
galvanized carbon steel, types
303 and 316 stainless steel

Position fixture, drill hole. Drive Rawl-Stud into hole until nut and washer are flush with fixture, and tighten.

FIXTURE CLEARANCE HOLES

Anchor Size	1/4"	3/8"	1/2"	5/8"	3/4"	7/8"	1"	1-1/4"
Clearance Hole	5/16"	7/16"	9/16"	11/16"	13/16"	15/16"	1-1/8"	1-3/8"

LOAD CAPACITIES FOR RAWL-STUD

TENSION LOAD (lbs.)			2,000 psi Concrete	4,000 psi Concrete	6,000 psi Concrete
Anchor Size	Embed Depth	Install Torque (ft.-lbs.)			
1/4"	1-1/4"	8	1,670	2,380	2,195
1/4"	1-1/2"	8	2,120	2,660	2,585
1/4"	2"	8	2,725	2,925	3,050
3/8"	1-5/8"	28	3,565	4,125	4,150
3/8"	2"	28	3,900	4,310	4,400
3/8"	3"	28	4,800	4,800	5,070
1/2"	2-1/4"	60	6,525	6,625	6,930
1/2"	3"	60	7,135	8,050	8,050
1/2"	4"	60	7,945	9,945	9,945
5/8"	2-3/4"	90	7,330	8,365	8,390
5/8"	4"	90	9,375	10,140	11,565
5/8"	5"	90	11,010	11,555	14,100
3/4"	3-3/8"	175	10,745	10,745	15,525
3/4"	5"	175	14,855	15,695	19,380
3/4"	6"	175	17,385	18,745	21,755
7/8"	3-7/8"	250	12,330	15,820	19,275
7/8"	4-1/2"	250	14,300	17,620	20,995
7/8"	5-3/4"	250	18,245	21,225	24,440
1"	4-1/2"	300	13,880	19,990	27,370
1"	5-1/2"	300	18,625	22,720	29,892
1"	6-1/2"	300	23,370	25,455	32,415
1-1/4"	5-5/8"	450	20,240	27,320	34,995
1-1/4"	7"	450	20,240	28,000	36,200

NOTE: The values listed above are ultimate load capacities for the carbon steel and stainless steel Rawl-Stud which should be reduced by minimum safety factor of 4 or greater to determine the allowable working load. Refer to the section on Selection and Specification of Anchors for details.

SPACES WITH ONE EXIT
1015.1 STORAGE OCCUPANCY MAXIMUM OF 29 OCCUPANTS. THE COMMON PATH OF EGRESS TRAVEL DOES NOT EXCEED 100 FT.

DOOR SWING
1008.1.2 DOOR SWING DOES NOT HAVE TO BE IN DIRECTION OF TRAVEL WHERE OCCUPANCY LOAD IS LESS THAN 50.

EXIT LIGHT NOT REQUIRED
1011.1 EXIT LIGHT NOT REQUIRED IN AREAS THAT HAVE ONLY ONE EXIT.

SHEAR LOAD (lbs.)

Anchor Size	Embed Depth	Install Torque (ft.-lbs.)	2,000 psi Concrete	4,000 psi Concrete	6,000 psi Concrete
1/4"	1-1/4"	8	1,450	2,070	2,080
1/4"	1-1/2"	8	1,655	2,075	2,080
1/4"	2"	8	1,925	2,080	2,080
3/8"	1-5/8"	28	3,840	5,185	5,810
3/8"	2"	28	4,265	5,420	5,925
3/8"	3"	28	5,390	6,040	6,230
1/2"	2-1/4"	60	6,405	6,930	6,985
1/2"	3"	60	6,620	7,190	7,295
1/2"	4"	60	6,905	7,535	7,710
5/8"	2-3/4"	90	8,850	8,850	10,095
5/8"	4"	90	9,215	9,680	10,385
5/8"	5"	90	9,505	10,345	10,620
3/4"	3-3/8"	175	14,660	14,660	15,265
3/4"	5"	175	15,770	17,110	18,045
3/4"	6"	175	16,450	18,620	19,755
7/8"	3-7/8"	250	18,630	19,230	21,035
7/8"	4-1/2"	250	19,590	21,035	22,235
7/8"	5-3/4"	250	20,435	21,635	24,040
1"	4-1/2"	300	24,335	25,120	27,475
1"	5-1/2"	300	25,590	27,475	29,045
1"	6-1/2"	300	26,690	28,260	31,400
1-1/4"	5-5/8"	450	38,035	39,265	42,945
1-1/4"	7"	450	41,720	44,170	49,080

WALK DOOR CLEAR SPACE
SCALE: 3/8" = 1'-0"

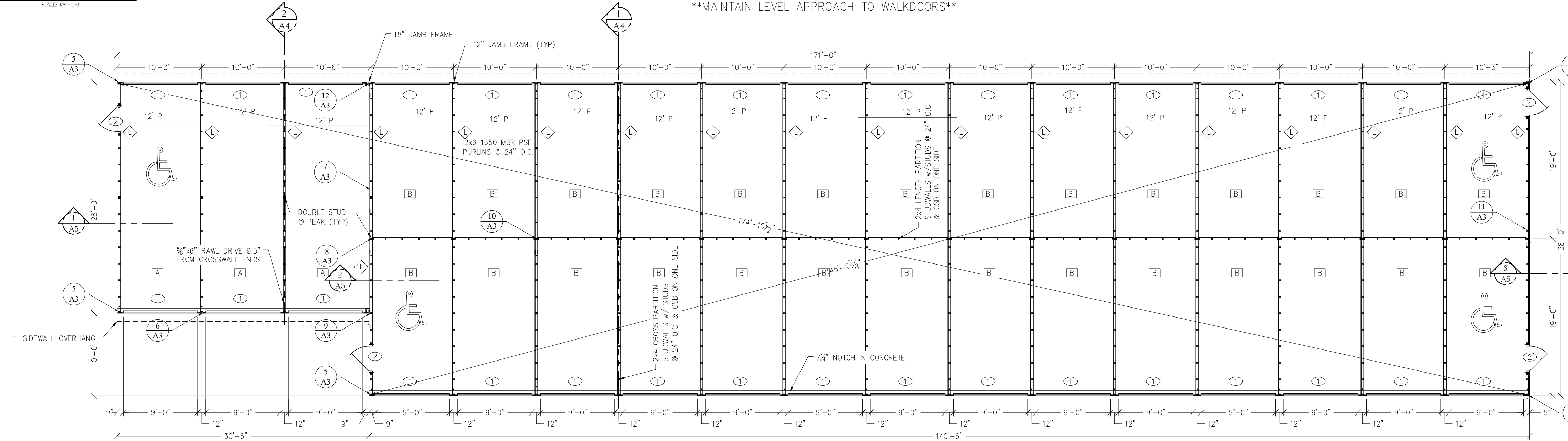

2 FRAMING PLAN
SCALE: 1/8" = 1'-0"

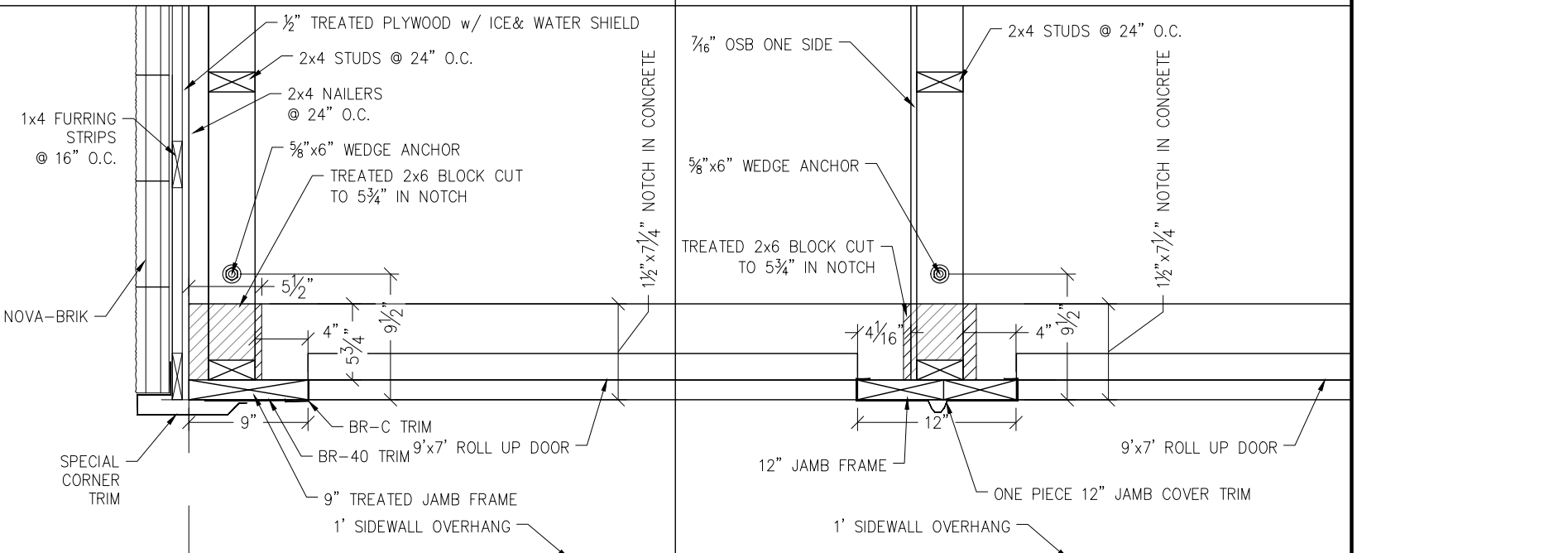

5 9" CORNER JAMB
SCALE: 1" = 1'-0"

6 12" JAMB
SCALE: 1" = 1'-0"

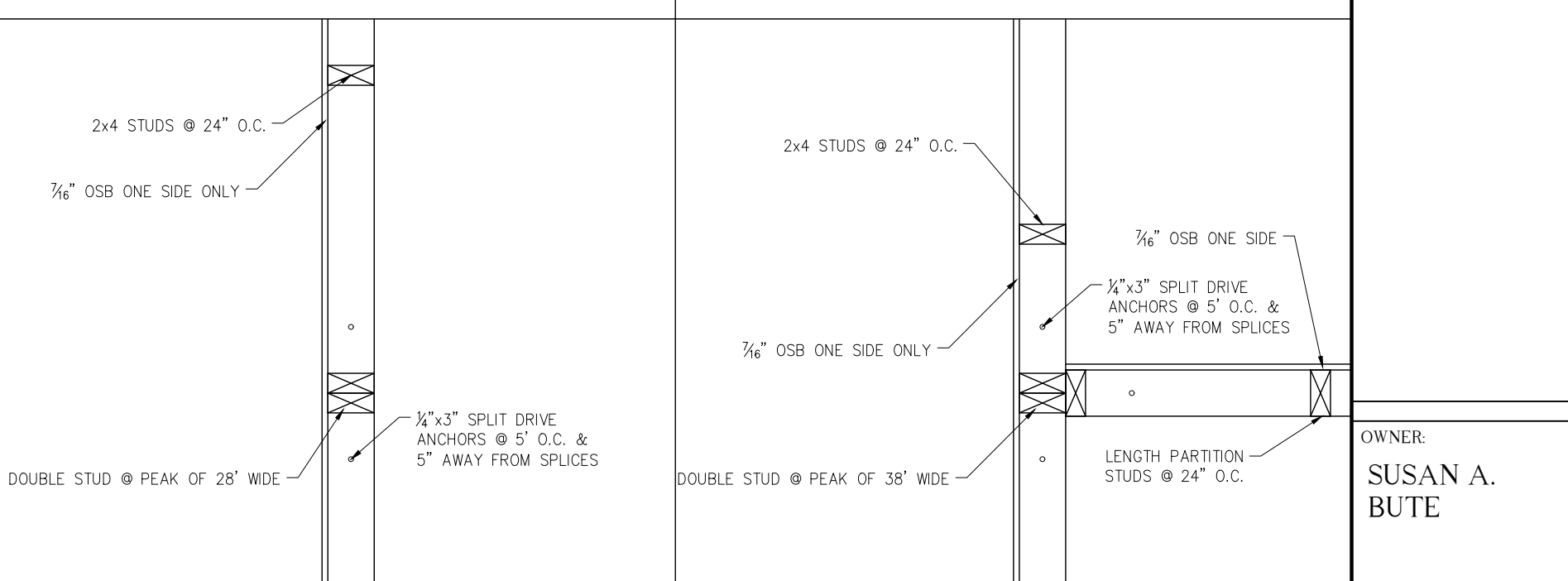

7 30" PEAK DETAIL
SCALE: 1" = 1'-0"

8 CROSS PARTITION
SCALE: 1" = 1'-0"

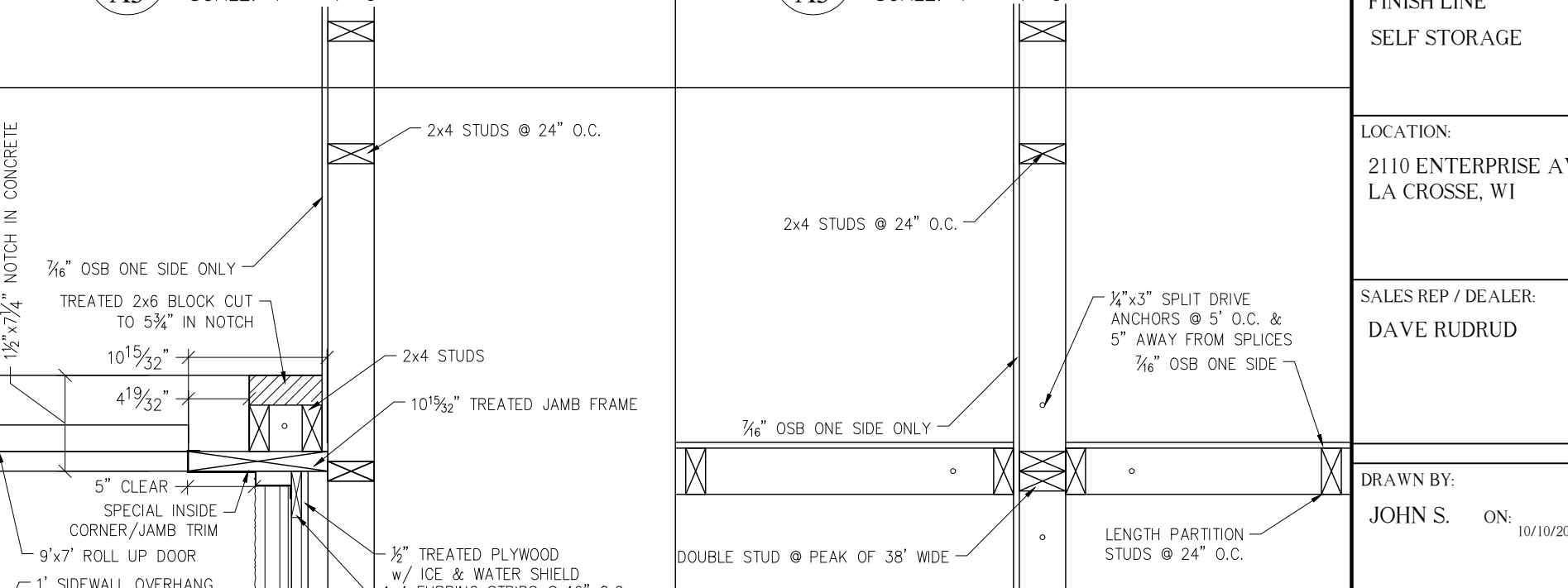

9 INSIDE CORNER JAMB
SCALE: 1" = 1'-0"

10 40' PEAK DETAIL
SCALE: 1" = 1'-0"

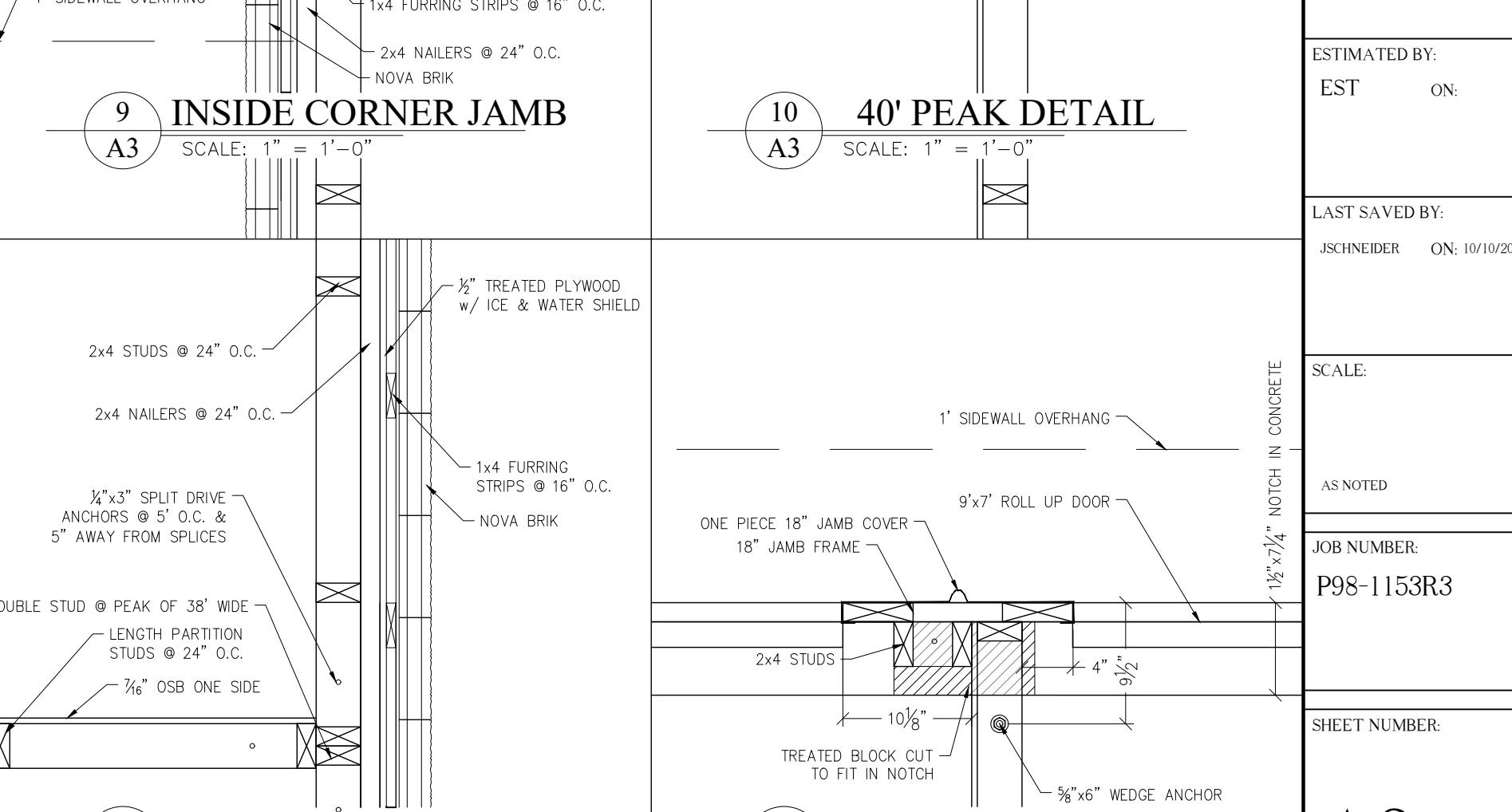

11 END BAY DETAIL
SCALE: 1" = 1'-0"

12 18" JAMB
SCALE: 1" = 1'-0"

Walters Buildings
Jack Walters & Sons, Corp.
P.O. Box 388
6600 Midland Ct.
Allenton, WI 53802
1-800-558-7800
www.waltersbuildings.com

REVISIONS

OWNER: SUSAN A. BUTE
PROJECT: FINISH LINE SELF STORAGE
LOCATION: 2110 ENTERPRISE AV. LA CROSSE, WI
SALES REP / DEALER: DAVE RUDRUD

DRAWN BY: JOHN S. ON: 10/10/2019

ESTIMATED BY: EST ON:

LAST SAVED BY: JSCINEBER ON: 10/10/2019

SCALE:

AS NOTED

JOB NUMBER: P98-1153R3

SHEET NUMBER:

A3



**Walters
Buildings**

Jack Walters & Sons, Corp.
P.O. Box 388
6600 Midland Ct.
Allenton, WI 53002
1-800-555-7800
www.waltersbuildings.com

REVISIONS:

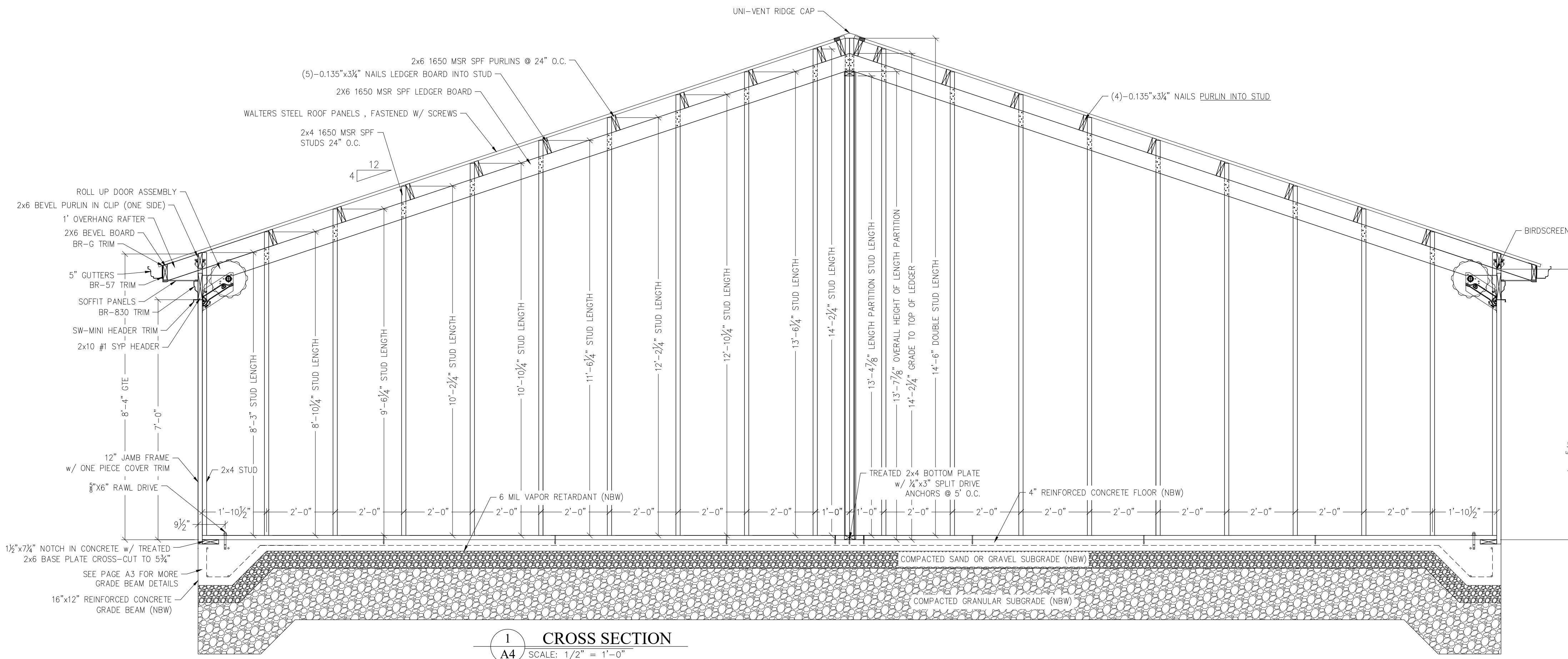

1 CROSS SECTION
SCALE: 1/2" = 1'-0"

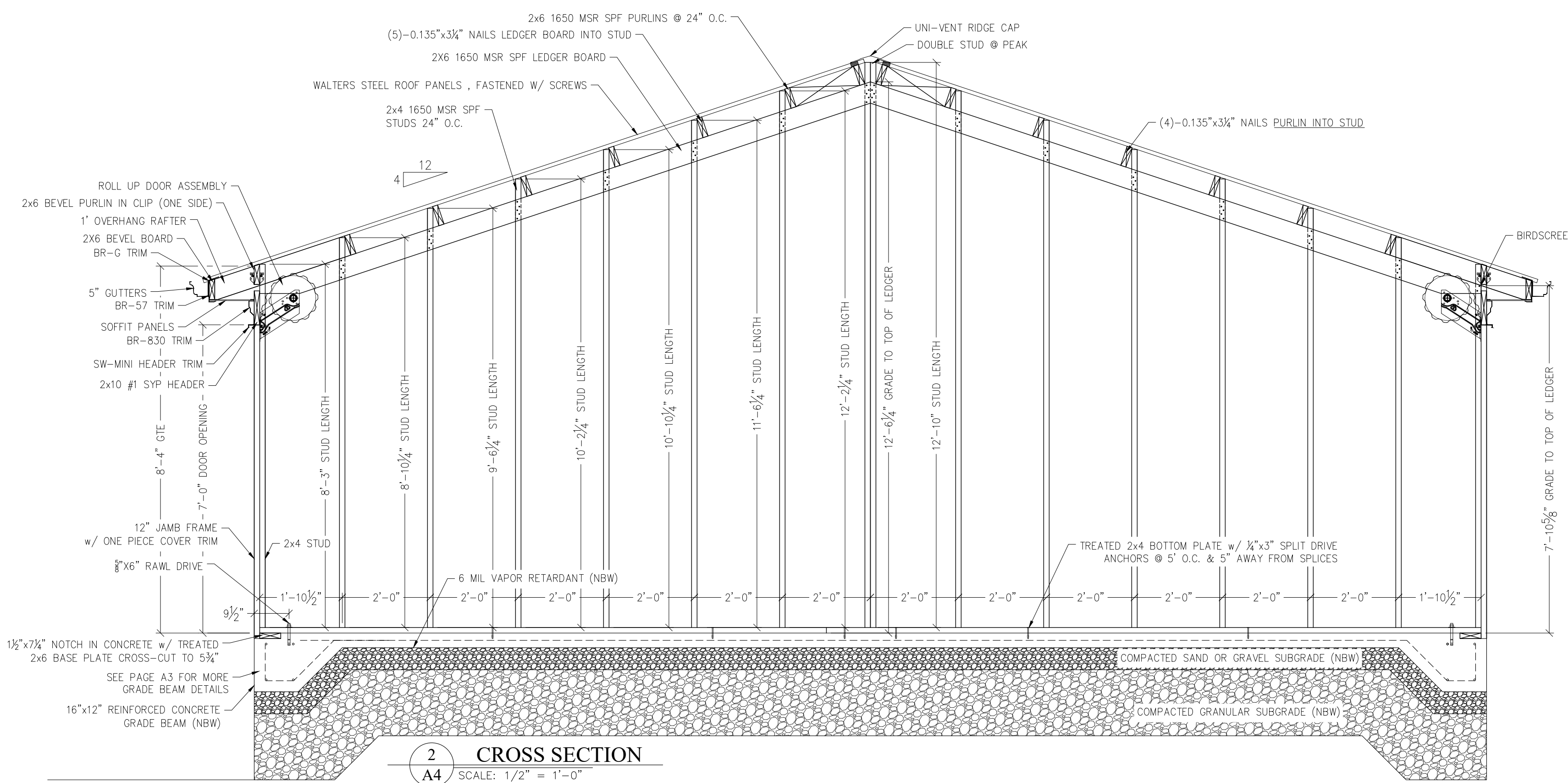

2 CROSS SECTION
SCALE: 1/2" = 1'-0"

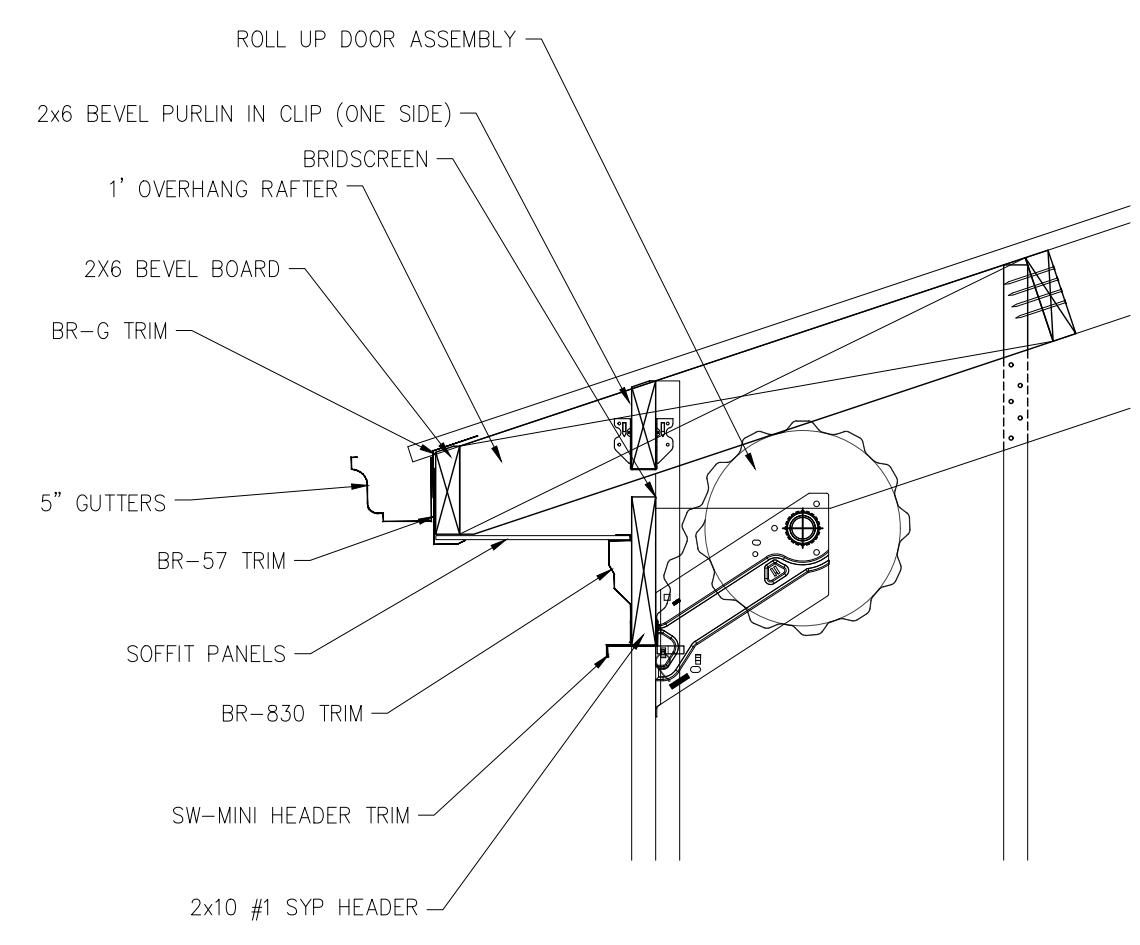

OWNER:
SUSAN A. BUTE

PROJECT:
FINISH LINE
SELF STORAGE

LOCATION:
2110 ENTERPRISE AV.
LA CROSSE, WI

SALES REP / DEALER:
DAVE RUDRUD

DRAWN BY:
JOHN S. ON: 10/10/2019

ESTIMATED BY:
EST ON:

LAST SAVED BY:
JSCINEBER ON: 10/10/2019

SCALE:
1/2" = 1'-0"

JOB NUMBER:
P98-1153R3

SHEET NUMBER:

A4



Walters Buildings

Jack Walters & Sons, Corp.
P.O. Box 388
6600 Midland Ct.
Allenton, WI 53002
1-800-555-7800
www.waltersbuildings.com

REVISIONS:

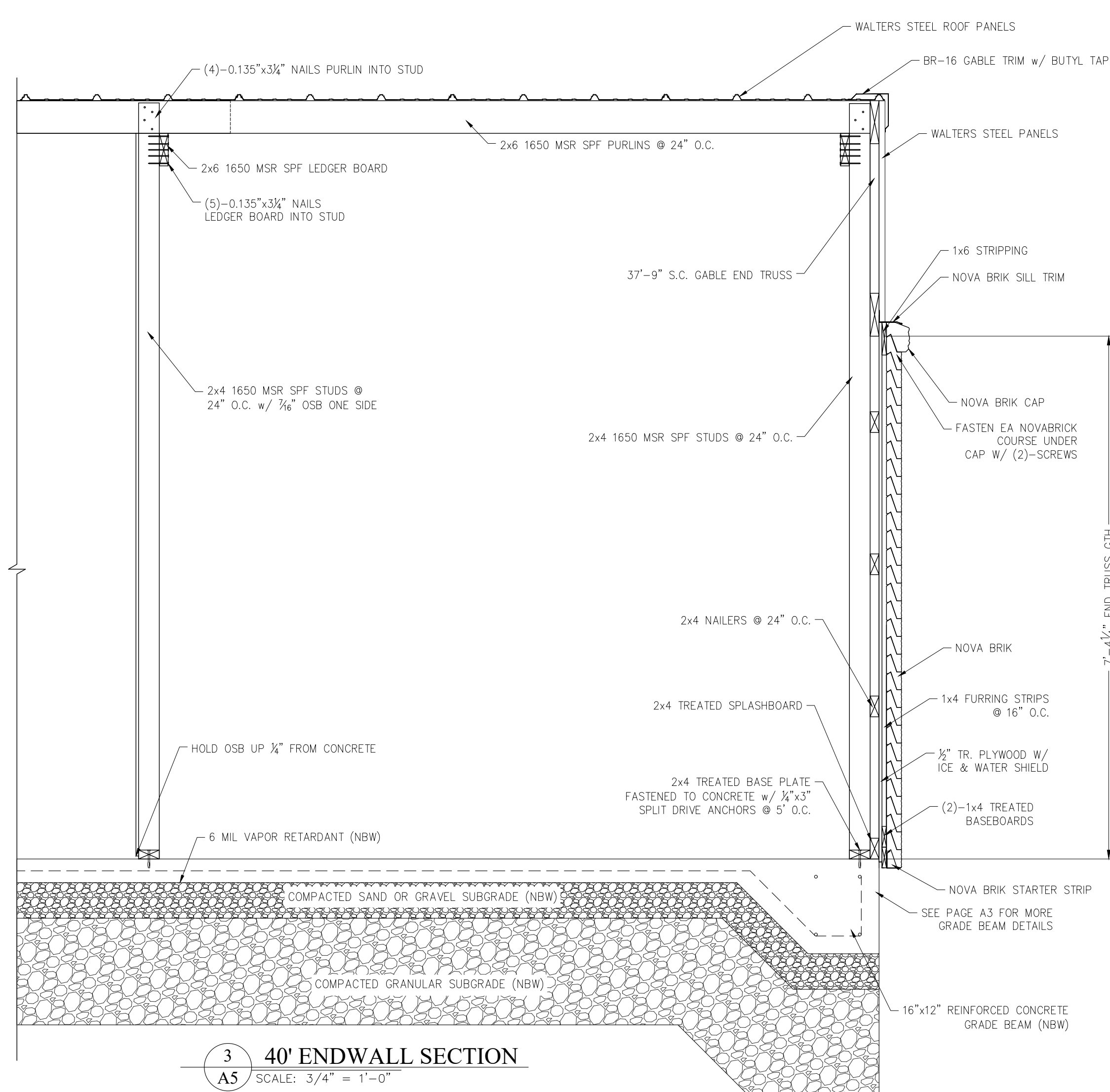
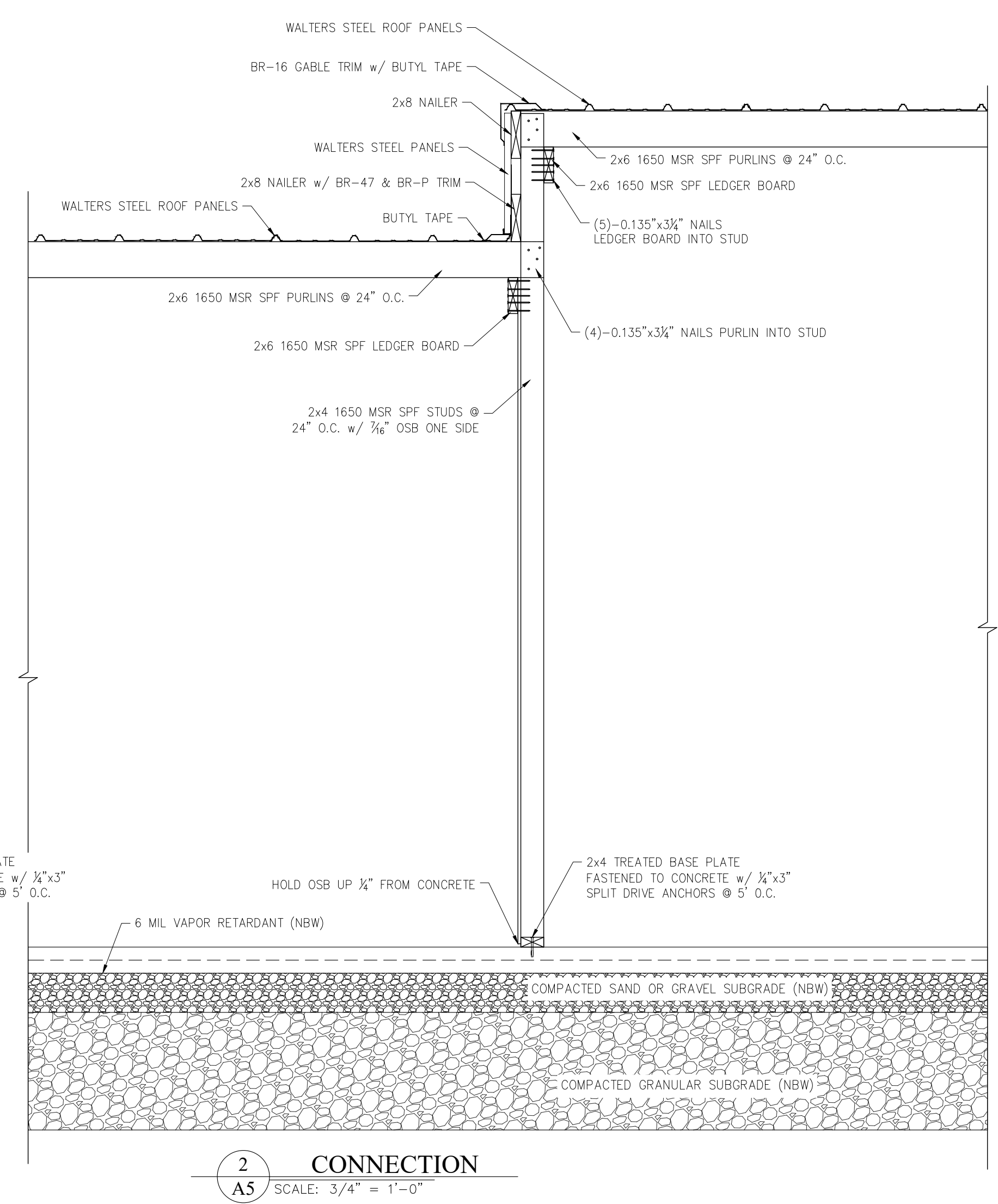
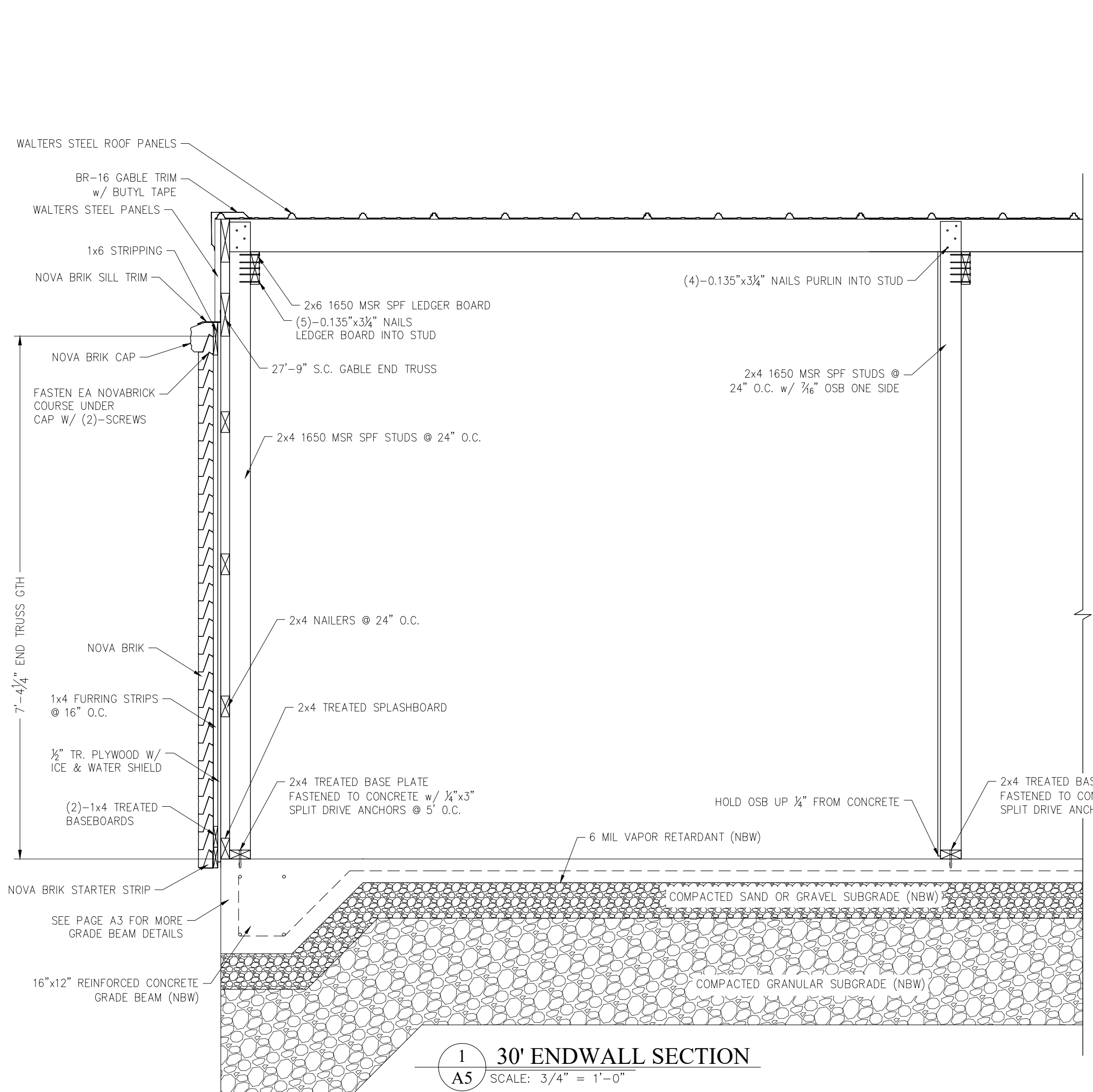

OWNER:
SUSAN A. BUTE

PROJECT:
FINISH LINE SELF STORAGE

LOCATION:
2110 ENTERPRISE AV.
LA CROSSE, WI

SALES REP / DEALER:
DAVE RUDRUD

DRAWN BY:
JOHN S. ON: 10/10/2019

ESTIMATED BY:
EST ON:

LAST SAVED BY:
JSCHEIDER ON: 10/10/2019

SCALE:
1/2" = 1'-0"

JOB NUMBER:
P98-1153R3

SHEET NUMBER:
A5



Walters Buildings

Jack Walters & Sons, Corp.
P.O. Box 388
6600 Midland Ct.
Allenton, WI 53002
1-800-555-7800
www.waltersbuildings.com

REVISIONS:

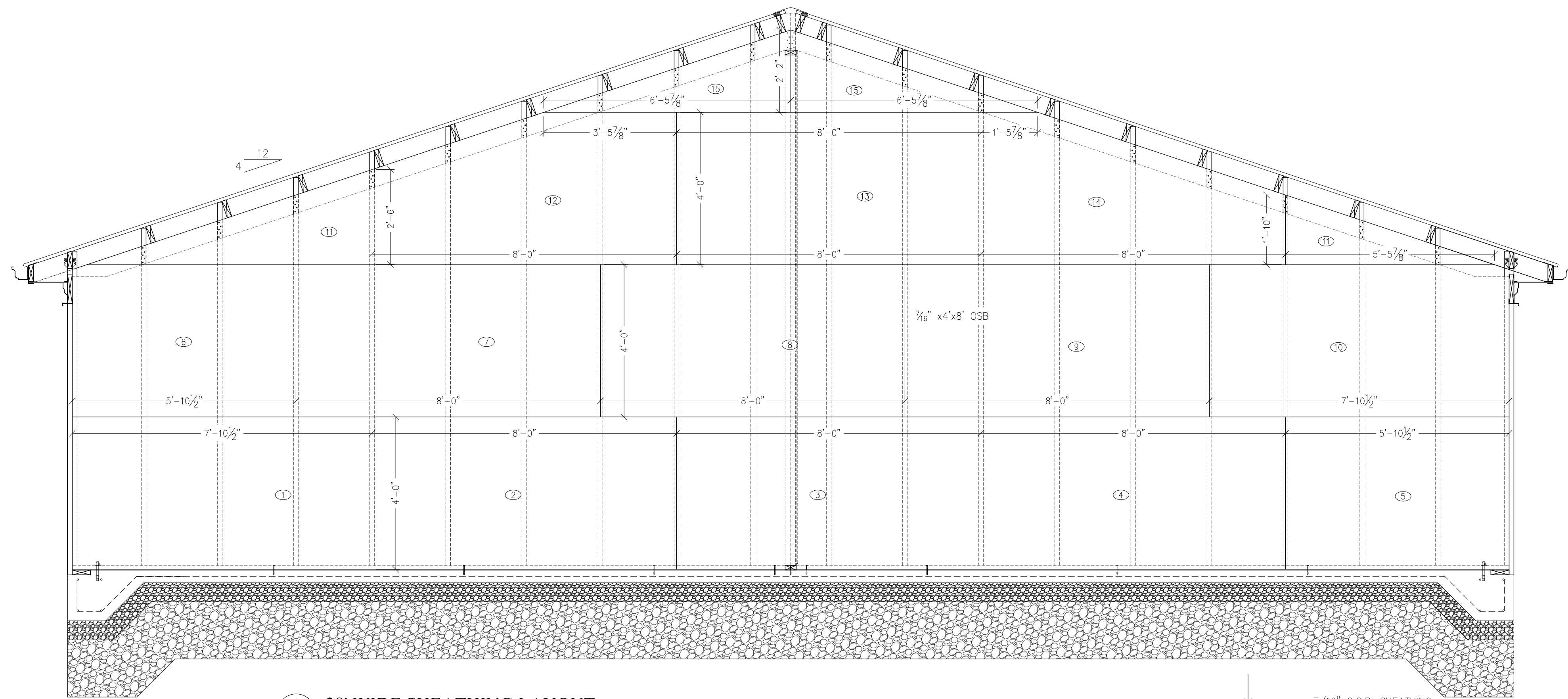

1 38' WIDE SHEATHING LAYOUT
A6 SCALE: 1/2" = 1'-0"

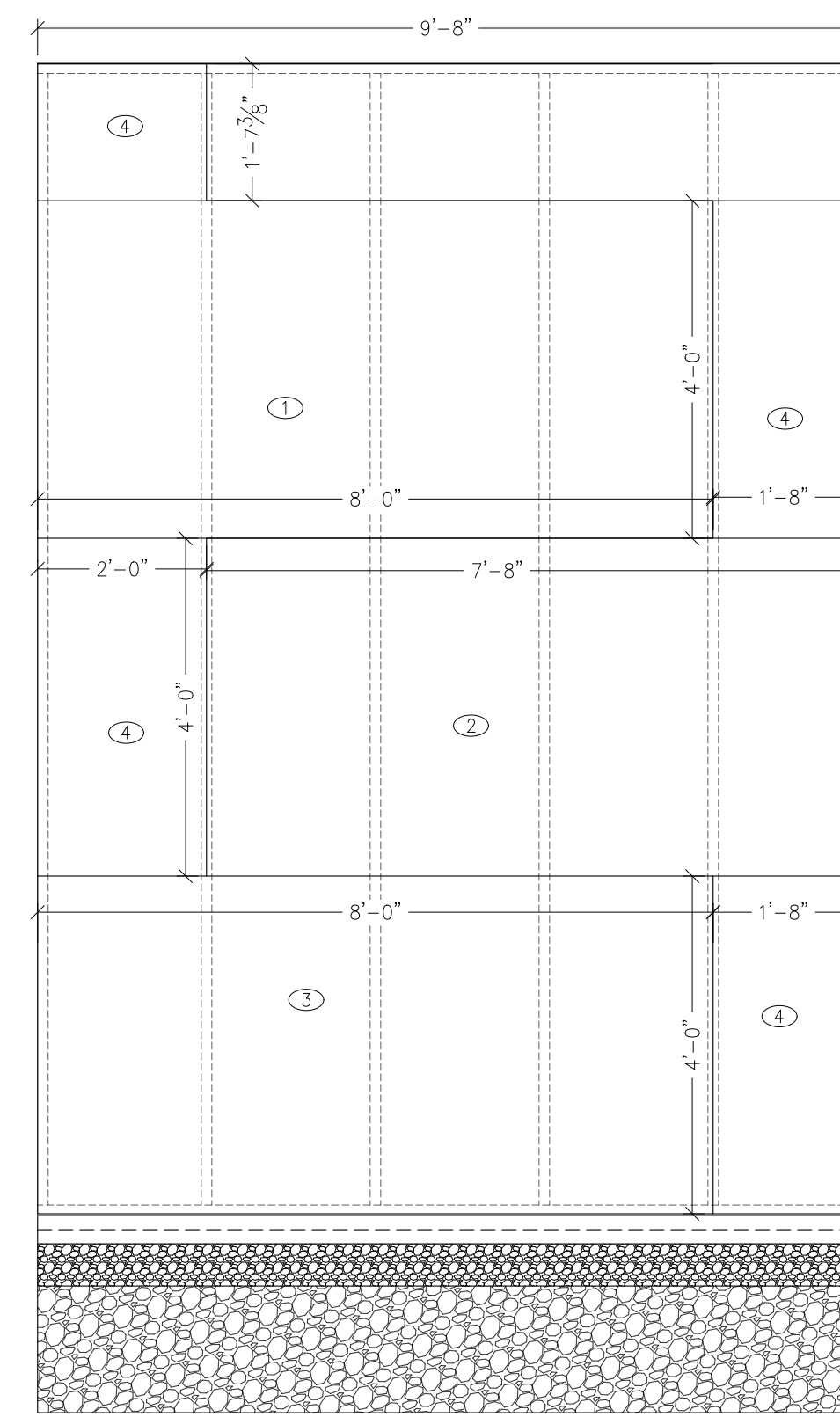

2 LENGTH PARTITION SHEATHING LAYOUT
A6 SCALE: 1/2" = 1'-0"

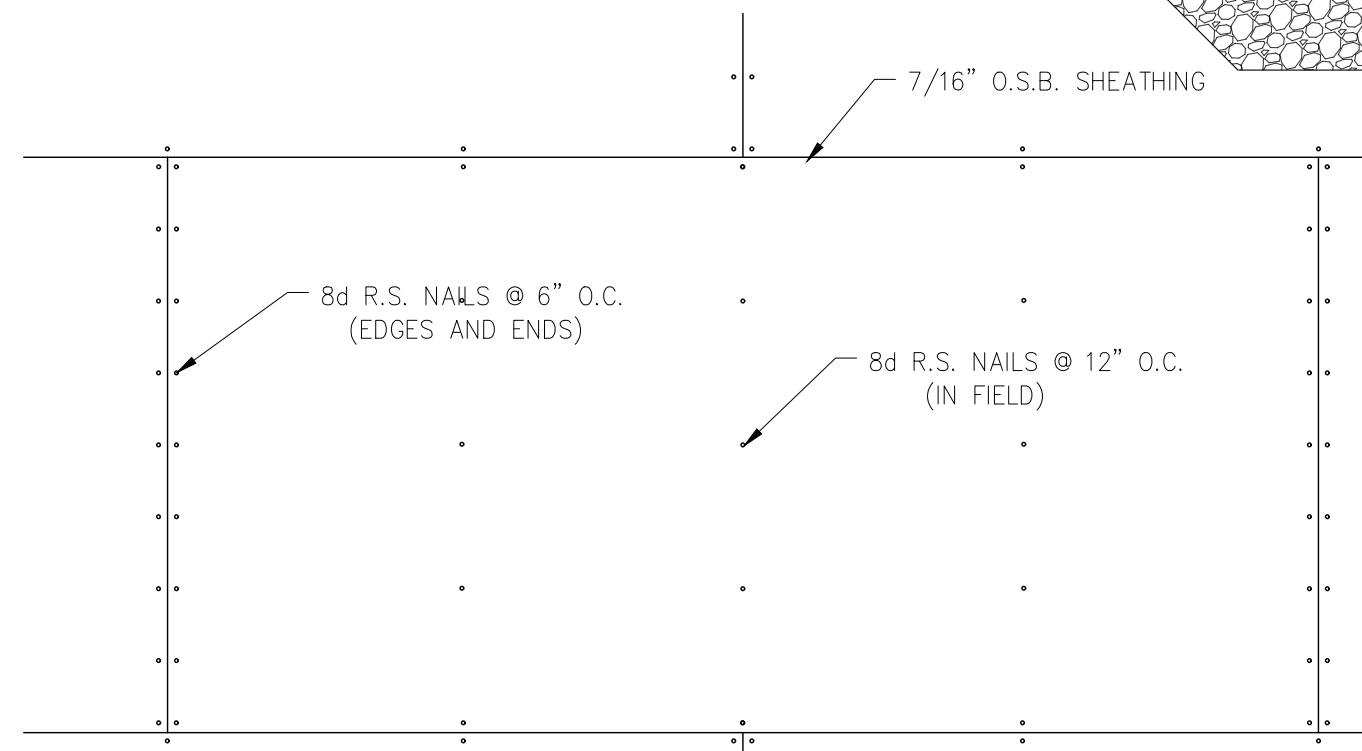

SHEATHING FASTENING LAYOUT

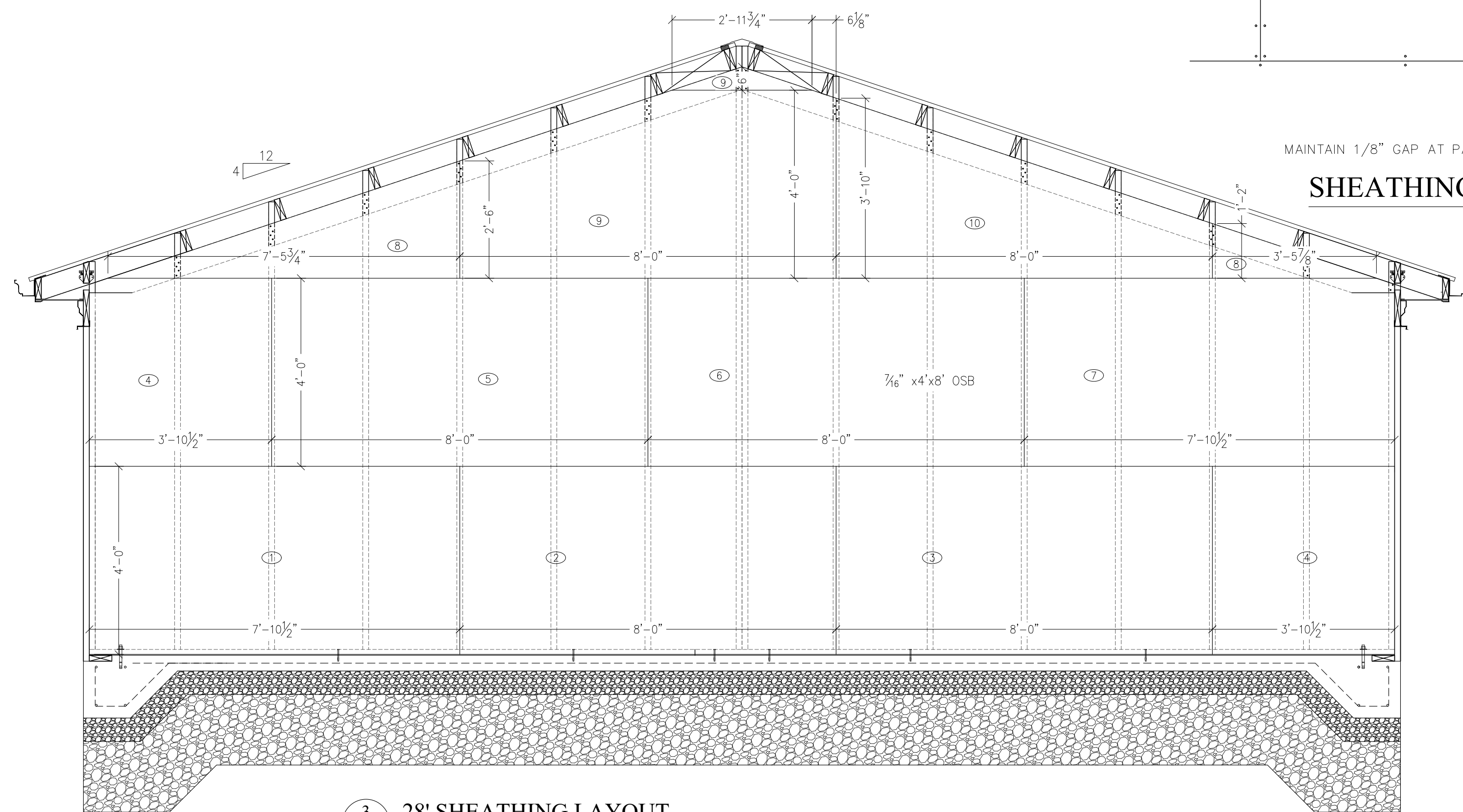

3 28' SHEATHING LAYOUT
A6 SCALE: 1/2" = 1'-0"

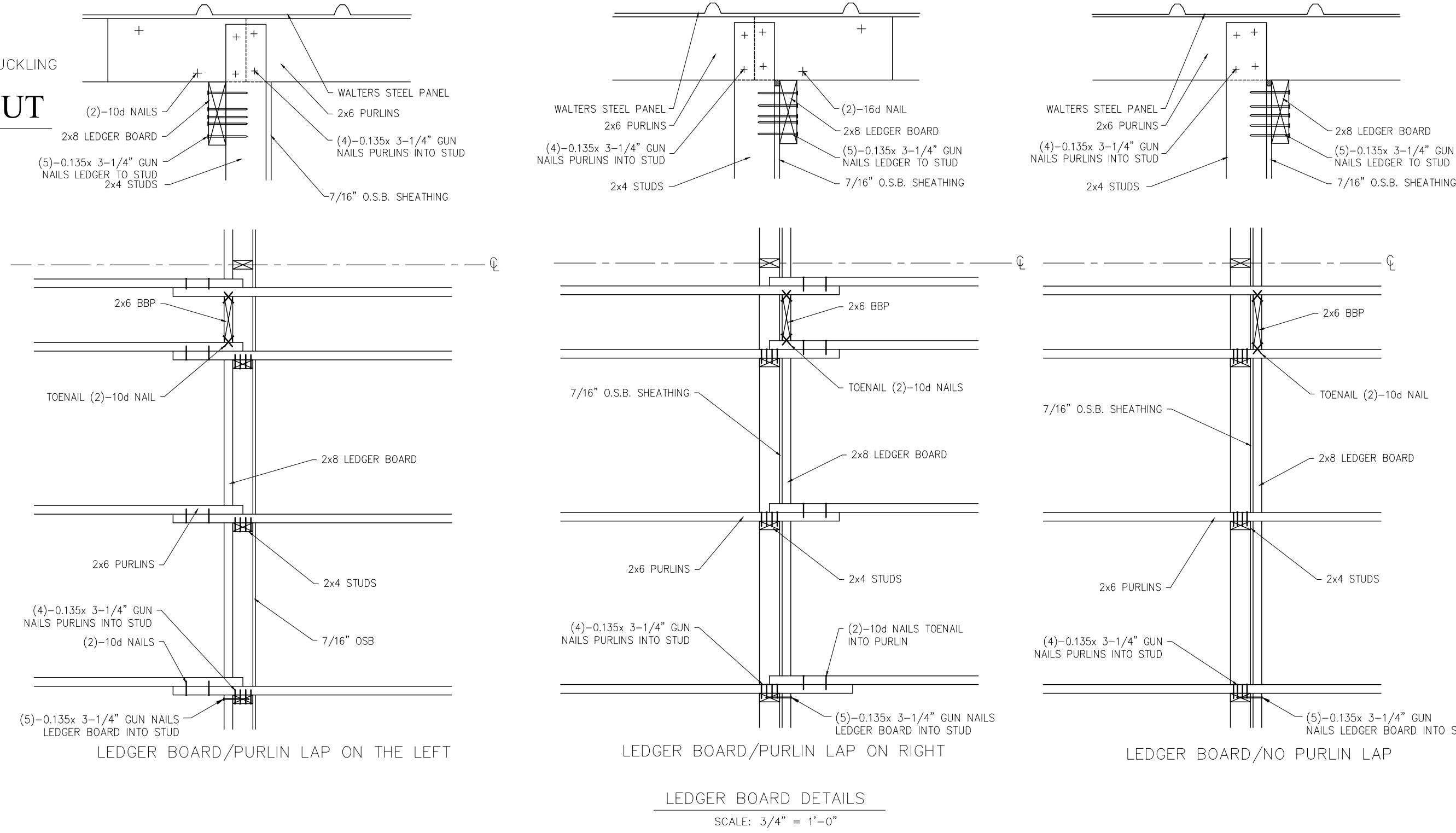

LEDGER BOARD/PURLIN LAP ON LEFT
LEDGER BOARD/PURLIN LAP ON RIGHT
LEDGER BOARD/NO PURLIN LAP
SCALE: 3/4" = 1'-0"

OWNER:
SUSAN A. BUTE

PROJECT:
FINISH LINE
SELF STORAGE

LOCATION:
2110 ENTERPRISE AV.
LA CROSSE, WI

SALES REP / DEALER:
DAVE RUDRUD

DRAWN BY:
JOHN S. ON: 10/10/2019

ESTIMATED BY:
EST ON:

LAST SAVED BY:
JSCINEIDER ON: 10/10/2019

SCALE:
1/2" = 1'-0"

JOB NUMBER:
P98-1153R3

SHEET NUMBER:

A6



Walters Buildings

Jack Walters & Sons, Corp.
P.O. Box 388
6600 Midland Ct.
Allenton, WI 53002
1-800-555-7800
www.waltersbuildings.com

REVISIONS

OWNER:
SUSAN A. BUTE

PROJECT:
FINISH LINE
SELF STORAGE

LOCATION:
2110 ENTERPRISE AV.
LA CROSSE, WI

SALES REP / DEALER:
DAVE RUDRUD

DRAWN BY:
JOHN S. ON: 10/10/2019

ESTIMATED BY:
EST ON:

LAST SAVED BY:
JSCHEIDER ON: 10/10/2019

SCALE:
AS NOTED

JOB NUMBER:
P98-1153R3

SHEET NUMBER:

P1

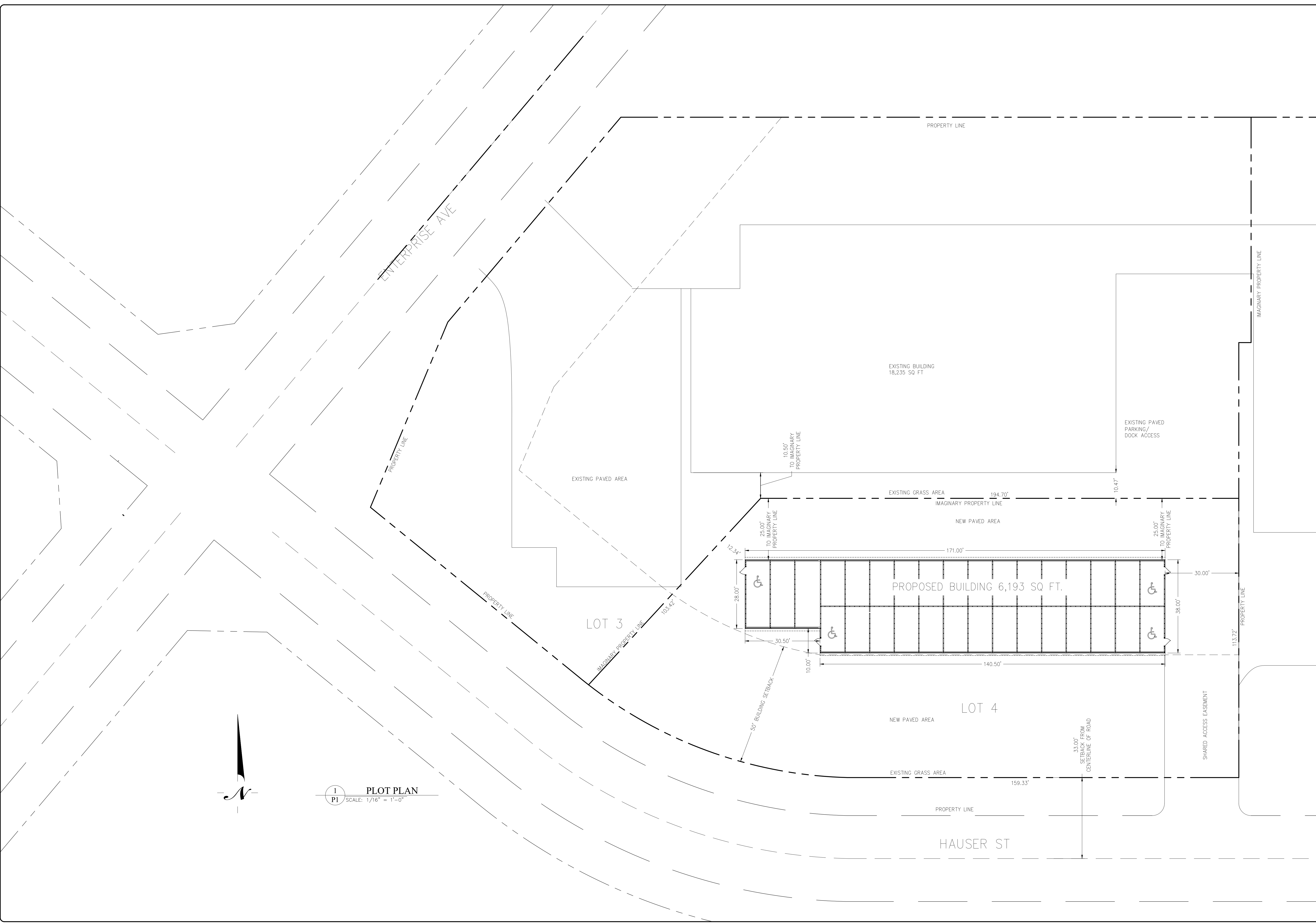

PLOT PLAN
SCALE: 1/16" = 1'-0"

PROPERTY LINE

ENTERPRISE AVE

EXISTING PAVED AREA

LOT 3

EXISTING BUILDING
18,235 SQ FT

EXISTING PAVED
PARKING/
DOCK ACCESS

EXISTING GRASS AREA
IMAGINARY PROPERTY LINE

NEW PAVED AREA

PROPOSED BUILDING 6,193 SQ FT.

LOT 4

NEW PAVED AREA

EXISTING GRASS AREA

HAUSER ST

SHARED ACCESS EASEMENT

IMAGINARY PROPERTY LINE

PROPERTY LINE

PROPERTY LINE

33.00'
SETBACK FROM
CENTERLINE OF ROAD

10.50'
TO IMAGINARY
PROPERTY LINE

25.00'
TO IMAGINARY
PROPERTY LINE

30.50'

50' BUILDING SETBACK

12.34'

103.42'

10.47'

194.70'

171.00'

140.50'

159.33'

113.72'
PROPERTY LINE