

OWNER
PEG ENTERPRISES LLC
2930 AIRPORT ROAD
LA CROSSE, WI 54601

CONTRACTOR
WIESER BROTHERS GENERAL CONTRACTOR, INC
200 TWILITE STREET
LA CRESSENT, MN 55947
507.895.8903

DESIGNER
MAKEPEACE ENGINEERING LLC
200 MASON STREET #15
ONALASKA, WI 54650
608.881.6030

LEGAL DESCRIPTION
AIRPORT INDUSTRIAL PARK LOT 20
LOT SIZE: 63656 SF

PROJECT ADDRESS
2930 AIRPORT ROAD
CITY OF LA CROSSE
LA CROSSE COUNTY, WI

BENCHMARK
TBD

CURRENT ZONING: M2—HEAVY INDUSTRIAL
PROPOSED USE: GYMNASIUM
DISTURBED AREA: 29707 SF
PROPOSED ADDITION AREA: 6,871 SF

ADJACENT	LAND USES
SOUTH	INDUSTRIAL
WEST	AIRPORT ROAD R-0-W
NORTH	INDUSTRIAL
EAST	AIRPORT

SIDE	SETBACK REQUIRED
FRONT	NONE
REAR	9'
NORTH	NONE
SOUTH	NONE

CONDITION	IMPERVIOUS	PERVIOUS	TOTAL
EXISTING	1.00 ACRE	0.46 ACRE	1.46 ACRE
PROPOSED	1.18 ACRE	0.28 ACRE	1.46 ACRE

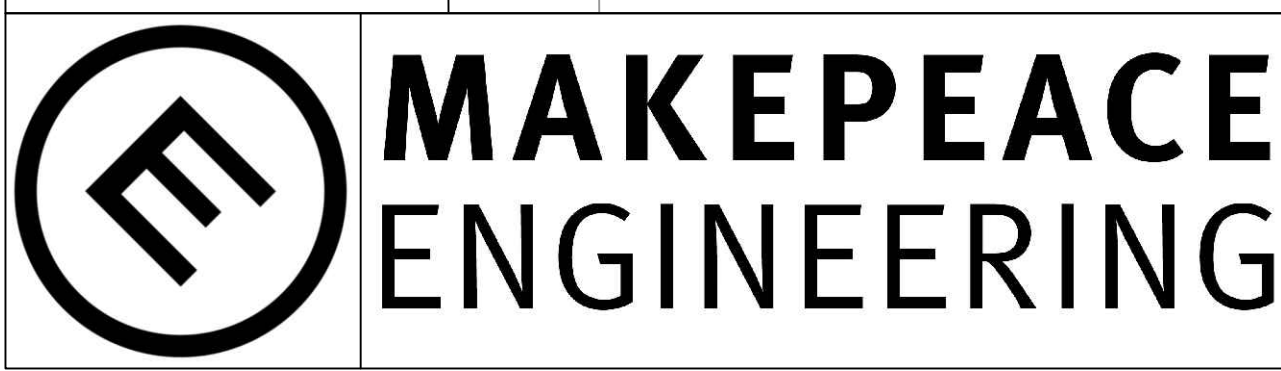
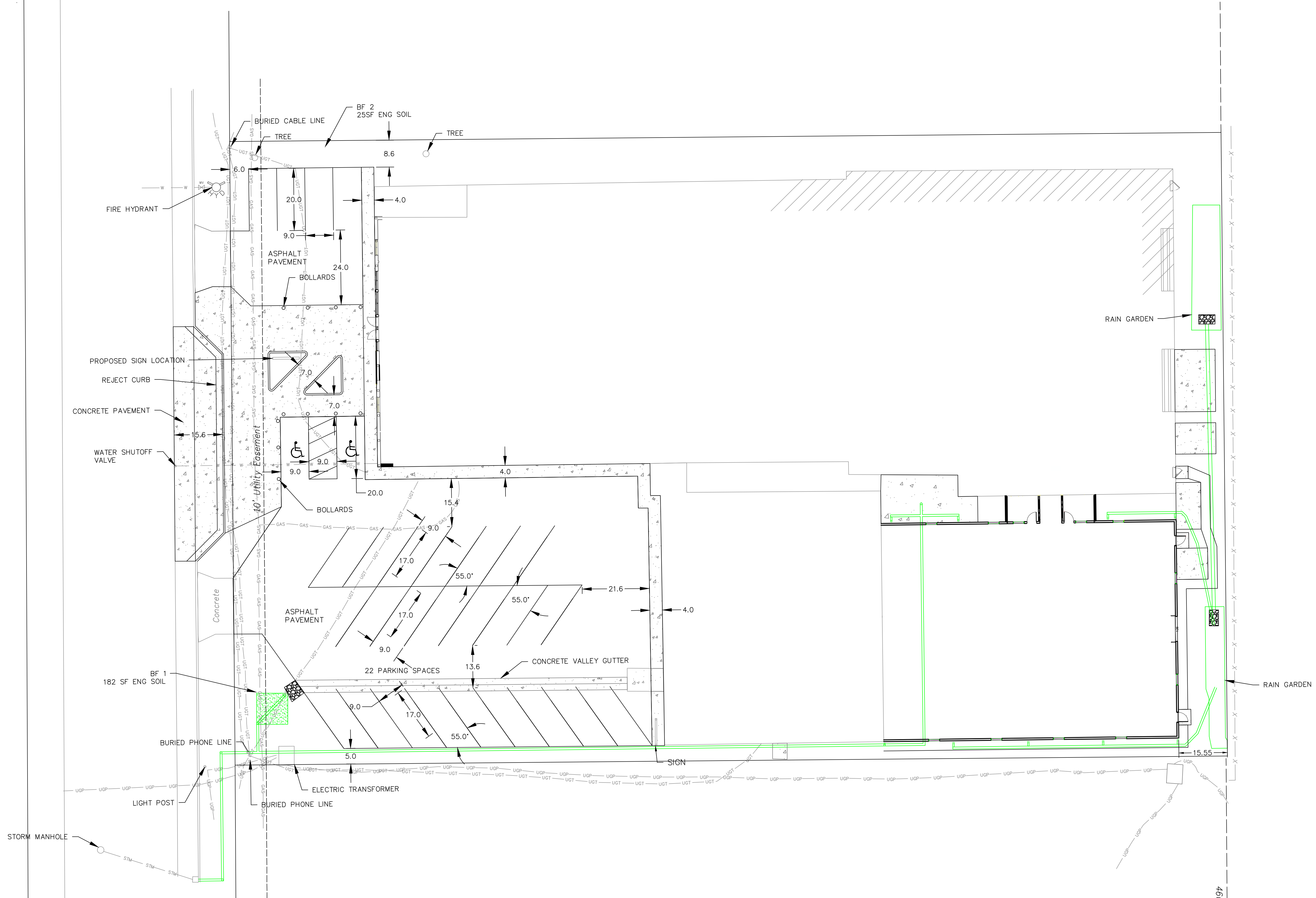

200 MASON STREET #15
ONALASKA, WI 54650
608.881.6030

PERFORMANCE ELITE
GYMNASIICS
2023 ADDITION
CITY OF LA CROSSE
LA CROSSE COUNTY

05/11/2023



SITE PLAN

DATE	REVISION	DESCR.

1
8

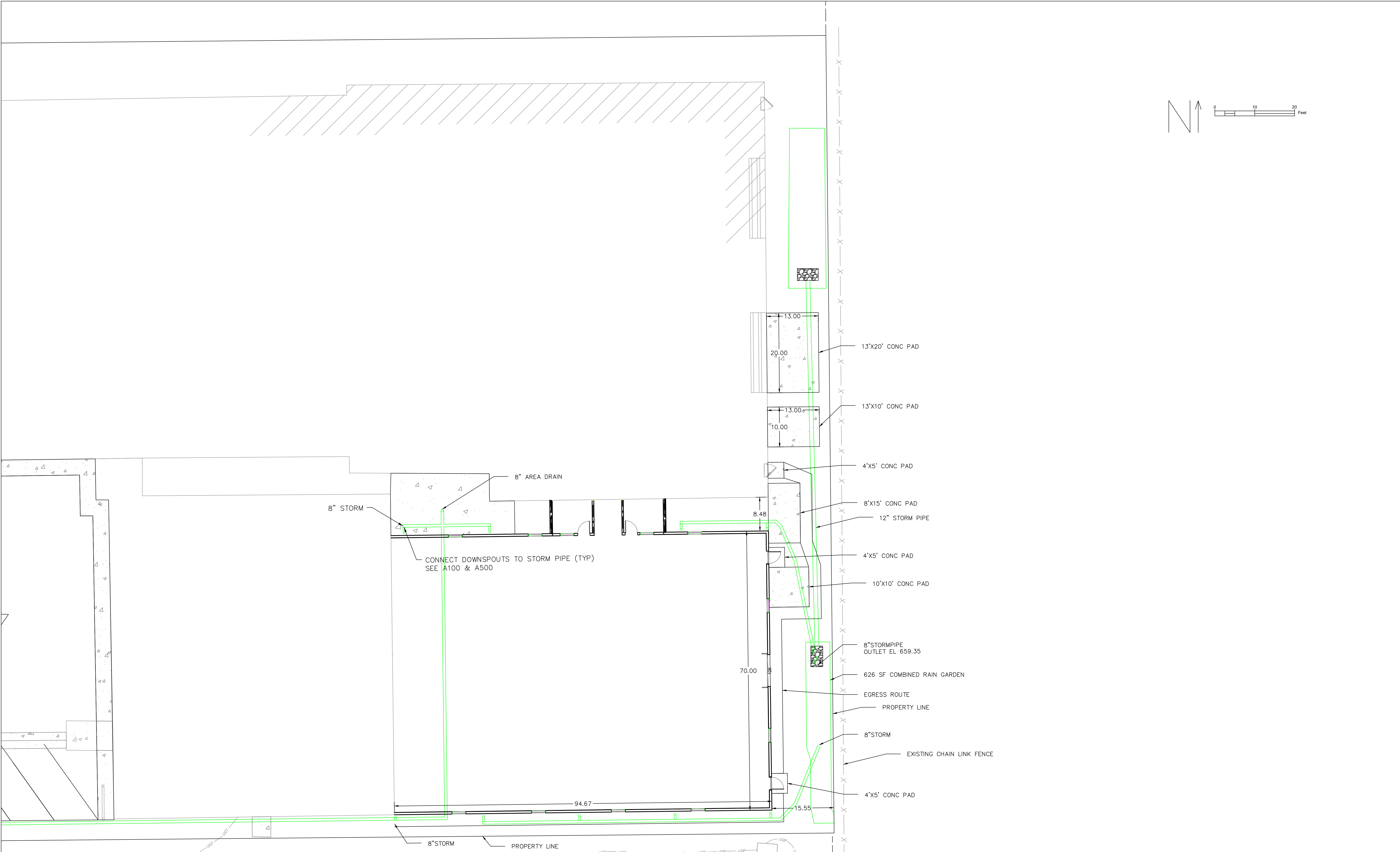
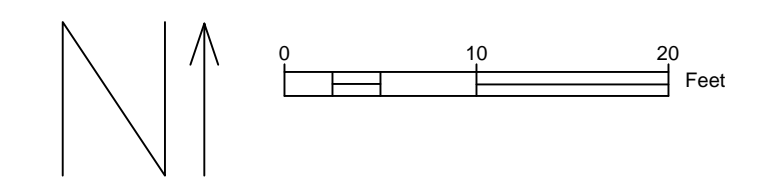

MAKEPEACE ENGINEERING

200 MASON STREET #15
 ONALASKA, WI 54650
 608.881.6030

PERFORMANCE ELITE GYMNASTICS
 2023 ADDITION
 CITY OF LA CROSSE
 LA CROSSE COUNTY

05/11/2023



REAR SITE PLAN

DATE	REVISION	DESCR.	2

RAIN GARDEN

CONCEPTUAL DRAWING ONLY.
SHOWN OUT OF PROJECTION.

ADJACENT MATERIALS, SLOPE, &
ELEVATION VARIES. SEE SITE PLAN.

SEED, MULCH & FERTILIZE
MITIGATE COMPACTION

ELEVATION A
SEE RAIN GARDEN ELEVATIONS TABLE

ELEVATION B
SEE RAIN GARDEN ELEVATIONS TABLE

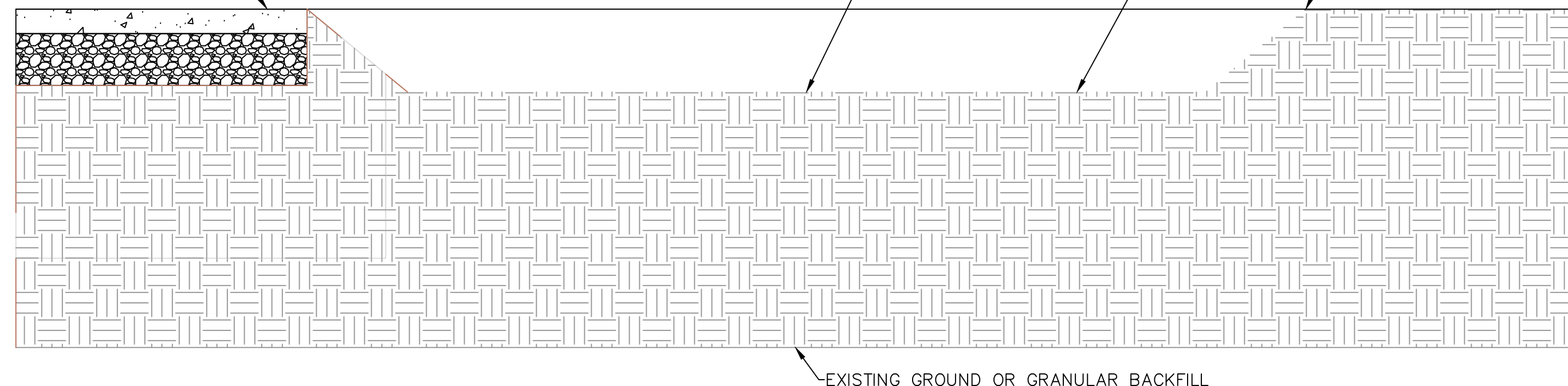

RAIN GARDEN ELEVATIONS

BIOFILTER	A	B
NORTHEAST	660.00	661.25
SOUTHEAST	659.35	661.25

CONSTRUCT RAIN GARDEN IN ACCORDANCE WITH WDNR TECHNICAL STANDARD 1009. THIS DEPICTION PROVIDED AS CONCEPT ONLY. ACTUAL INSTALLATION DETAILS FOR ADJACENT MATERIALS VARY AND ARE SHOWN ON THE SITE PLAN.

CONCRETE PAVEMENT

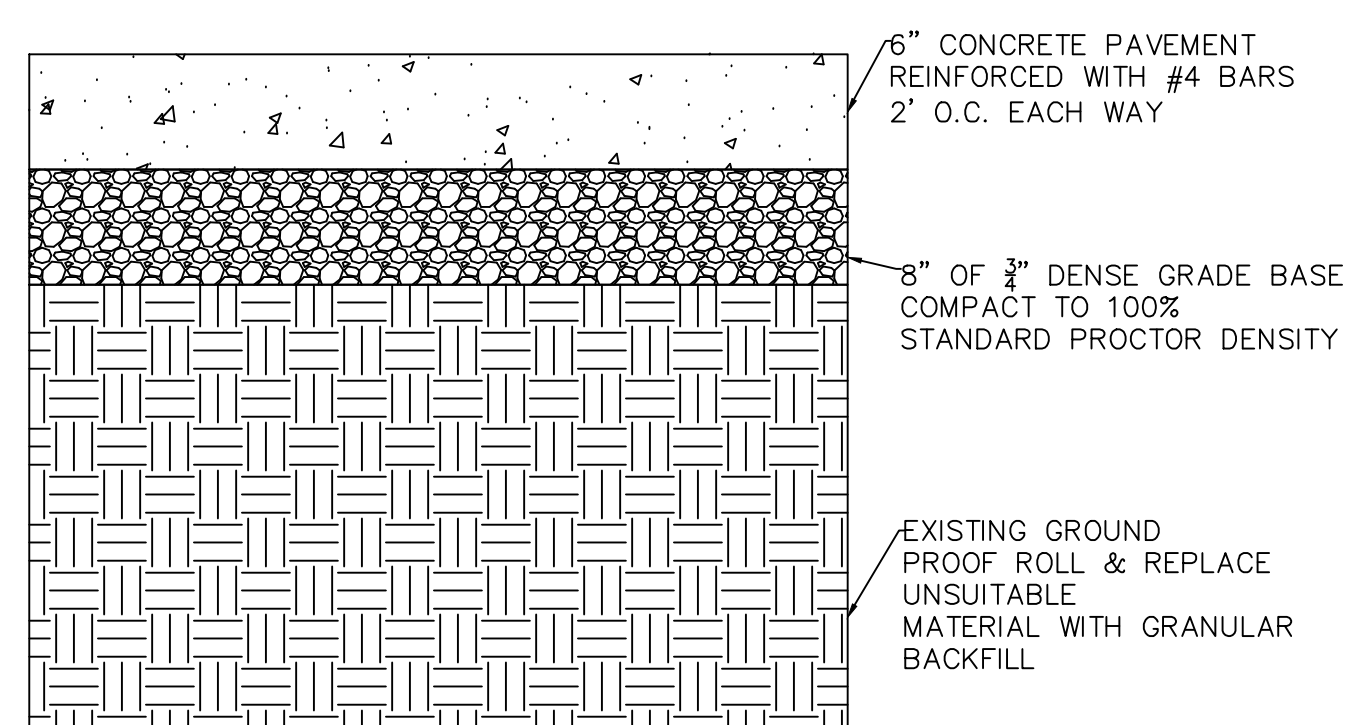

ASPHALT PAVEMENT

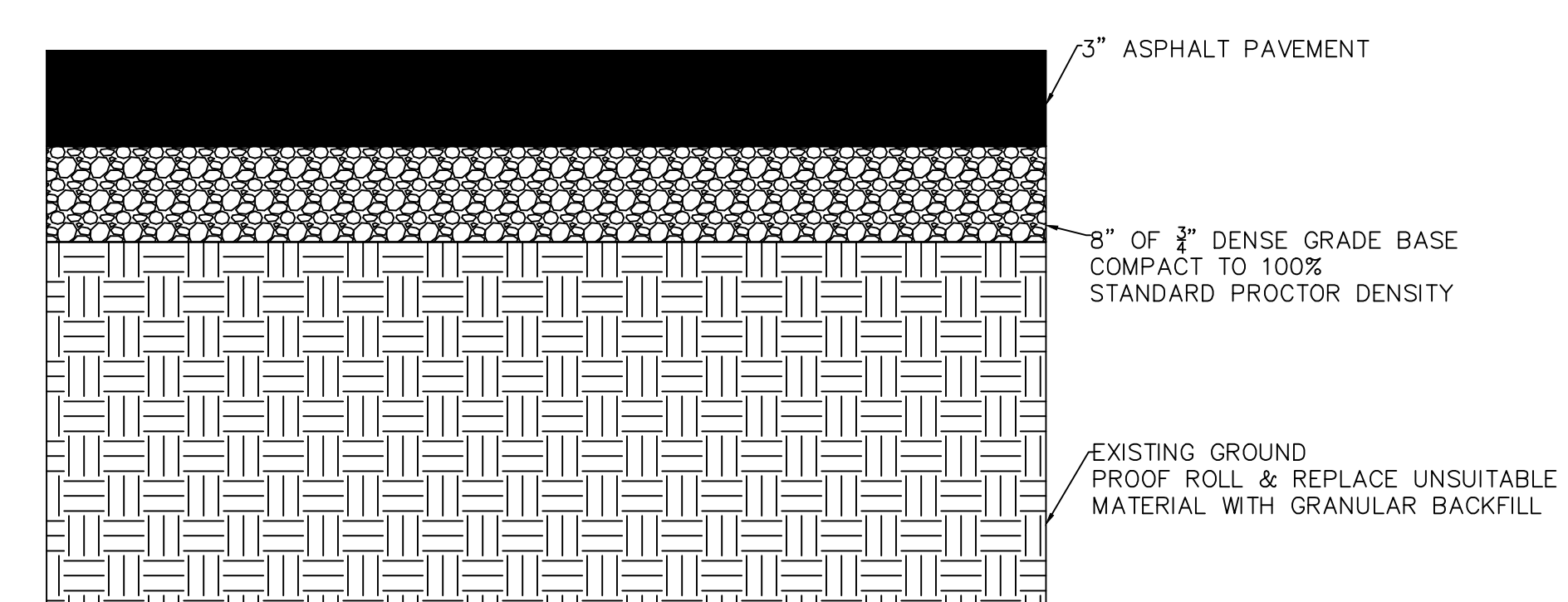

BIOFILTER TYPICAL SECTION

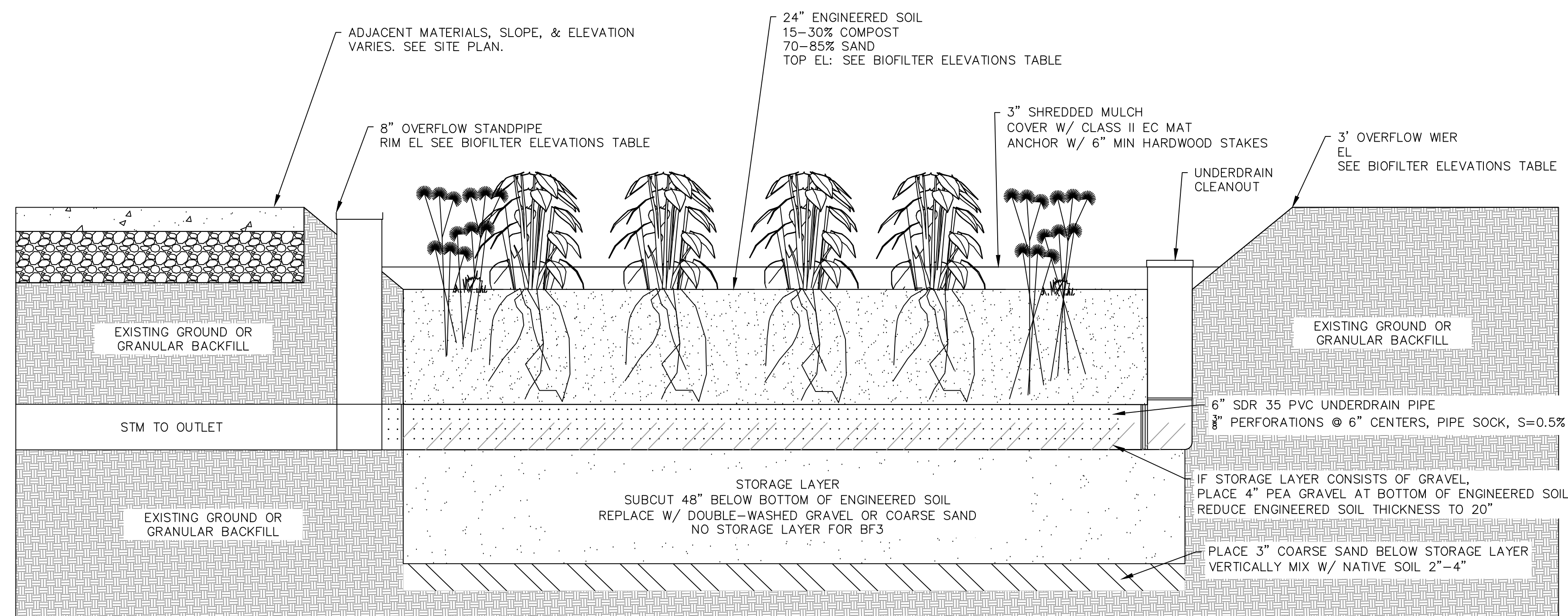

BIOFILTER ELEVATIONS

BIOFILTER	BOTTOM OF ENG. SOIL EL.	TOP OF ENG. SOIL EL.	STANDPIPE EL.	WEIR INV EL.
1	659.68'	661.68'	662.18	N/A

- CONSTRUCTION NOTES:**
- CONSTRUCT BIOFILTER IN ACCORDANCE WITH WDNR TECHNICAL STANDARD 1004 PROVIDED AS CONCEPT ONLY. ACTUAL INSTALLATION DETAILS FOR ADJACENT MATERIALS VARY AND ARE SHOWN ON THE SITE PLAN.
 - GRAVEL SHALL BE COARSE AGGREGATE #2 MEETING THE STANDARDS OF THE WISCONSIN STANDARDS AND SPECIFICATIONS FOR HIGHWAY AND STRUCTURE CONSTRUCTION (WSSHSC), S. 501.2.5, 2003 ED.
 - COARSE SAND SHALL BE USDA COARSE SAND, FINE AGGREGATE CONCRETE SAND (ASTM 05C33), OR EQUIVALENT AS SPECIFIED IN WSSHSC S. 501.2.5.3.4, 2005 ED.
 - PLANT WITH NATIVE DECORATIVE GRASSES AND PLANTS.
 - PLUGS SHALL BE PLACED 1' ON CENTER.
 - PLANT SELECTION SHALL BE BASED ON ENGINEERED SOIL COMPOSITION AS WELL AS NATIVE SOIL CONDITIONS BENEATH THE ENGINEERED SOIL LAYER.
 - SELECTED PLANTS SHALL BE DEEP ROOTED.
 - SELECTED PLANTS SHALL BE APPROVED BY OWNER PRIOR TO PLANTING.

SIDEWALK

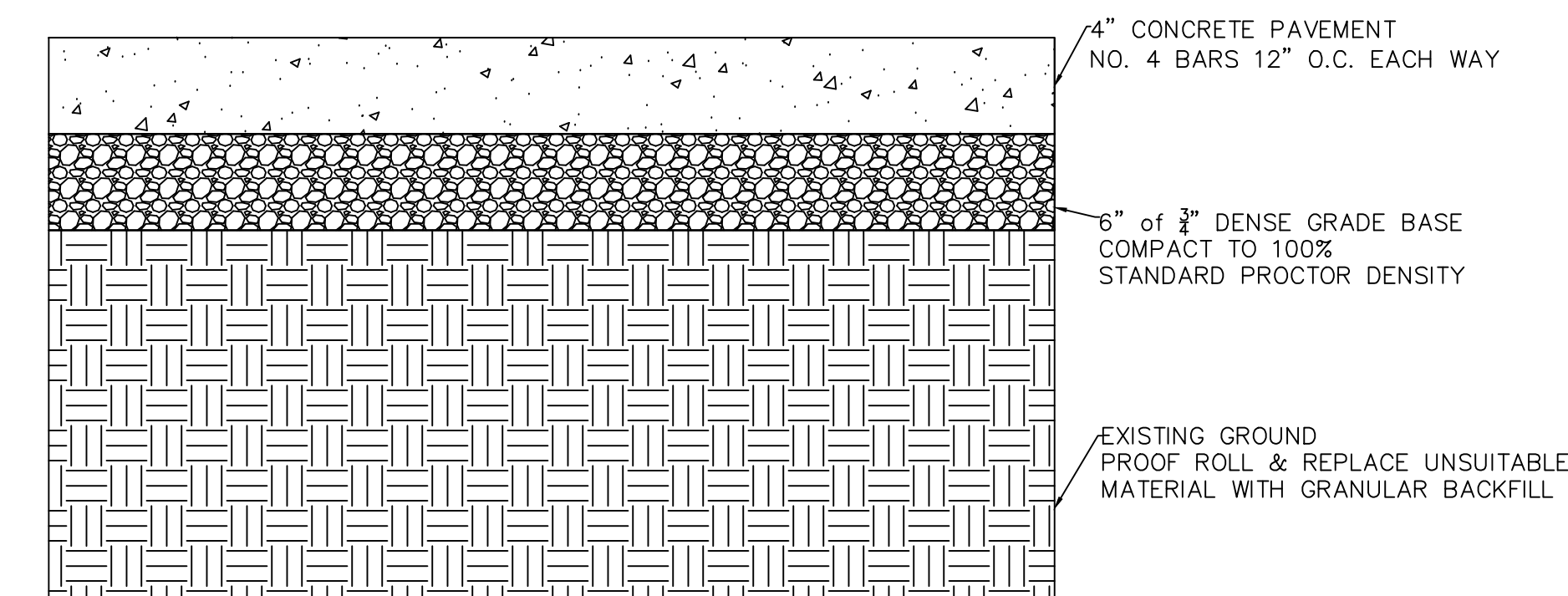

VALLEY GUTTER

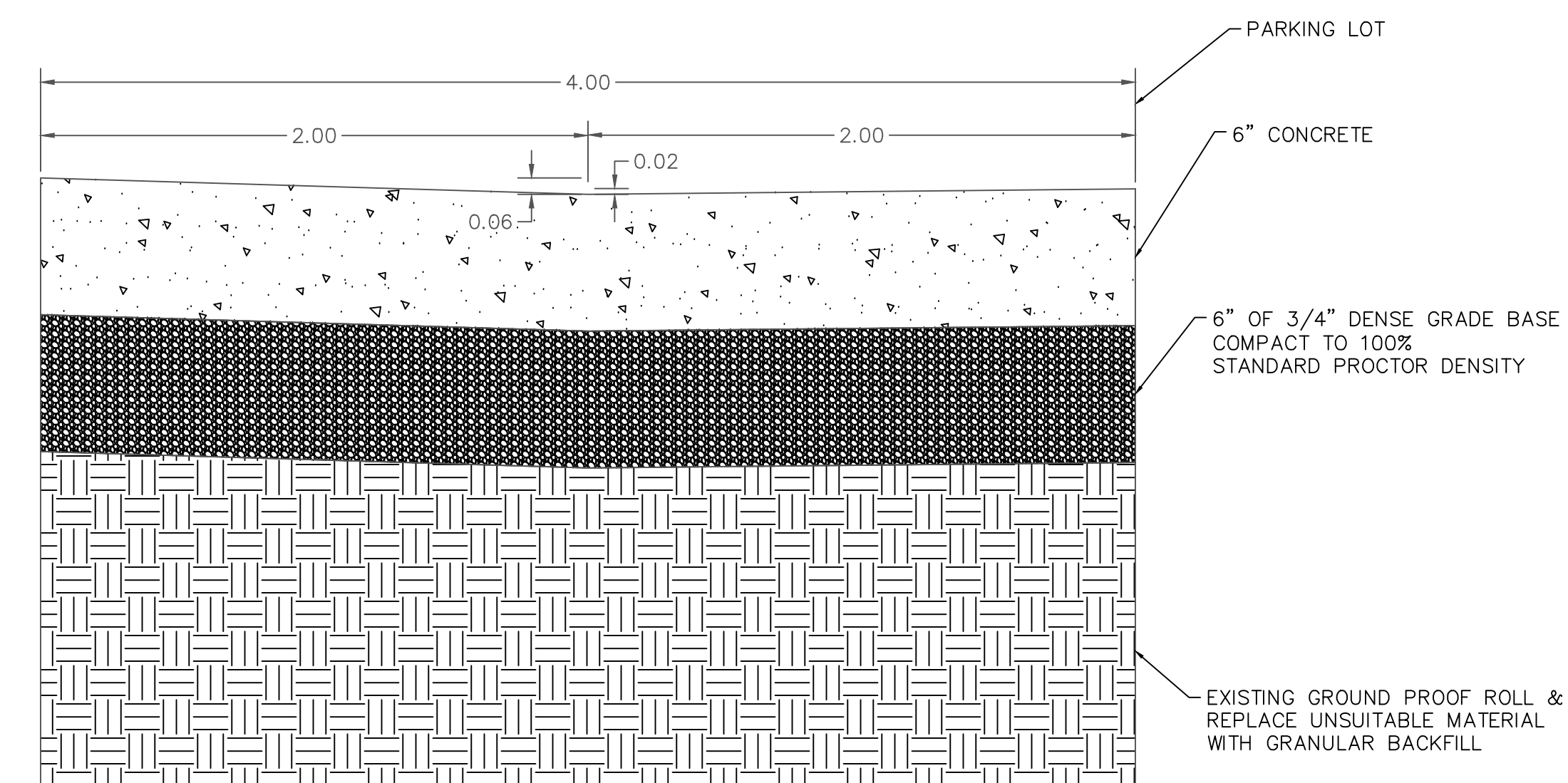

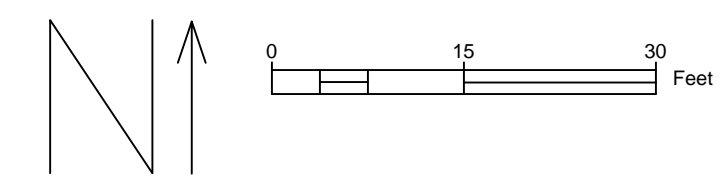

NOTES:
 8" STM SHALL BE SDR 35 PVC
 12" STM SHALL BE SMOOTH WALL, CORRUGATED HDPE

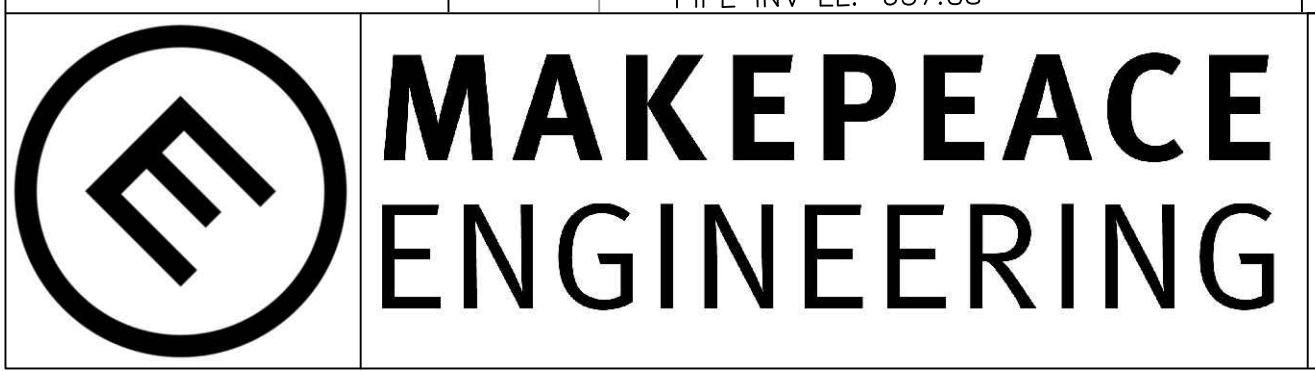
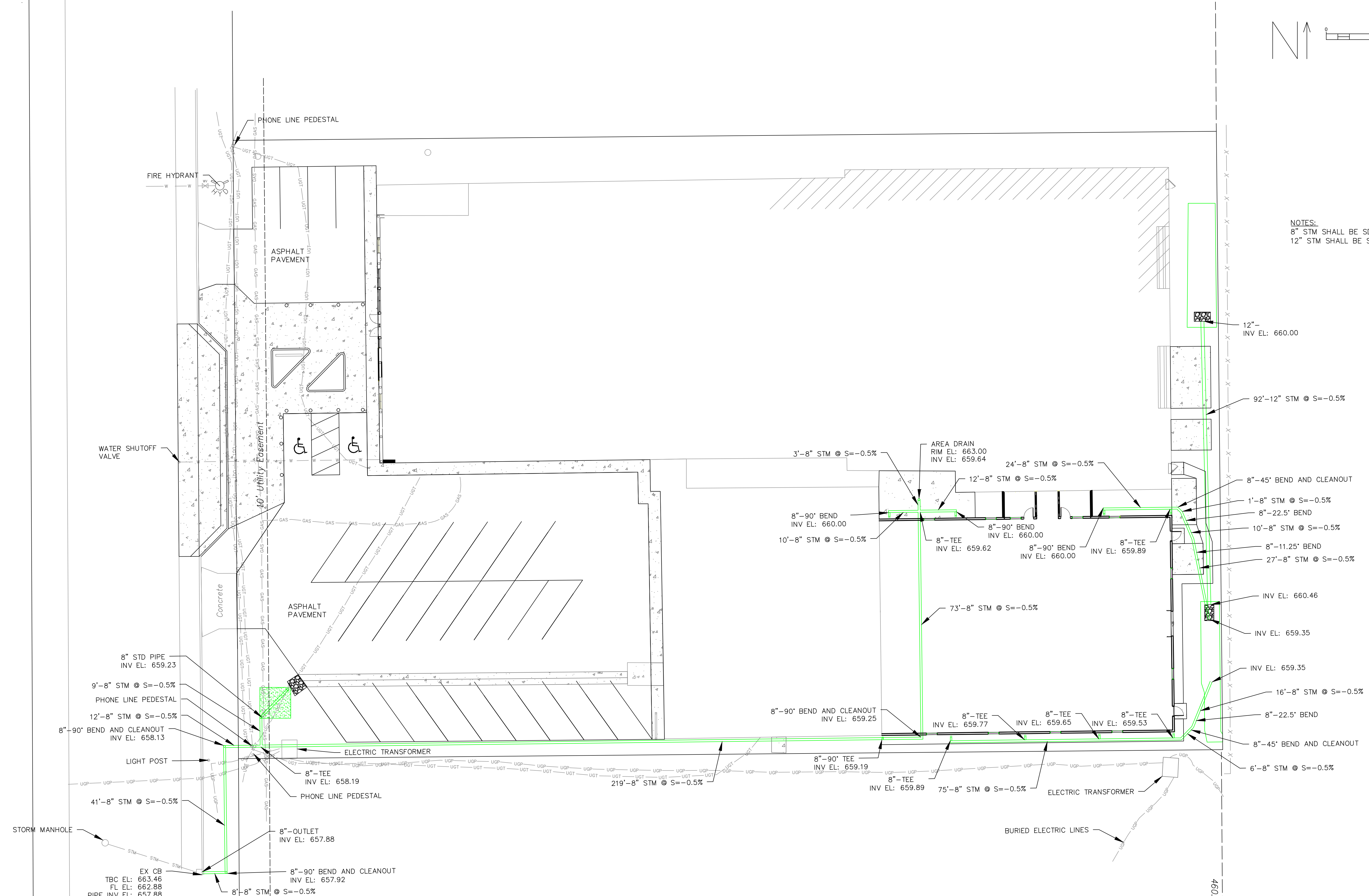

MAKEPEACE ENGINEERING
 200 MASON STREET #15
 ONALASKA, WI 54650
 608.881.6030

PERFORMANCE ELITE GYMNASTICS
 2023 ADDITION
 CITY OF LA CROSSE
 LA CROSSE COUNTY

05/11/2023



UTILITY PLAN

DATE	REVISION	DESCR.	
			6
			8

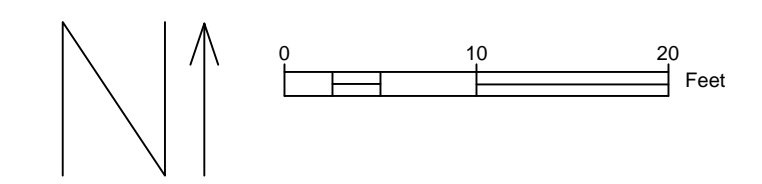

PLAN SHEET LEGEND	
	EROSION MAT CLASS I TYPE B TECH. STD. 1052
	SEED WITH ANCHORED MULCH TECH. STD. 1058 & 1059
	SILT FENCE TECH. STD. 1066
	EROSION MAT CLASS III TYPE B TECH. STD. 1052
	TRACKING PAD TECH. STD. 1057

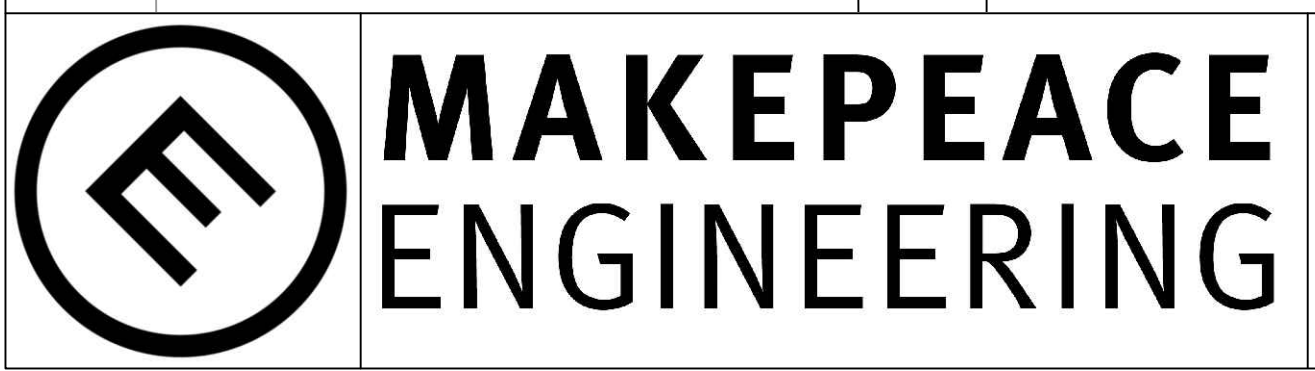
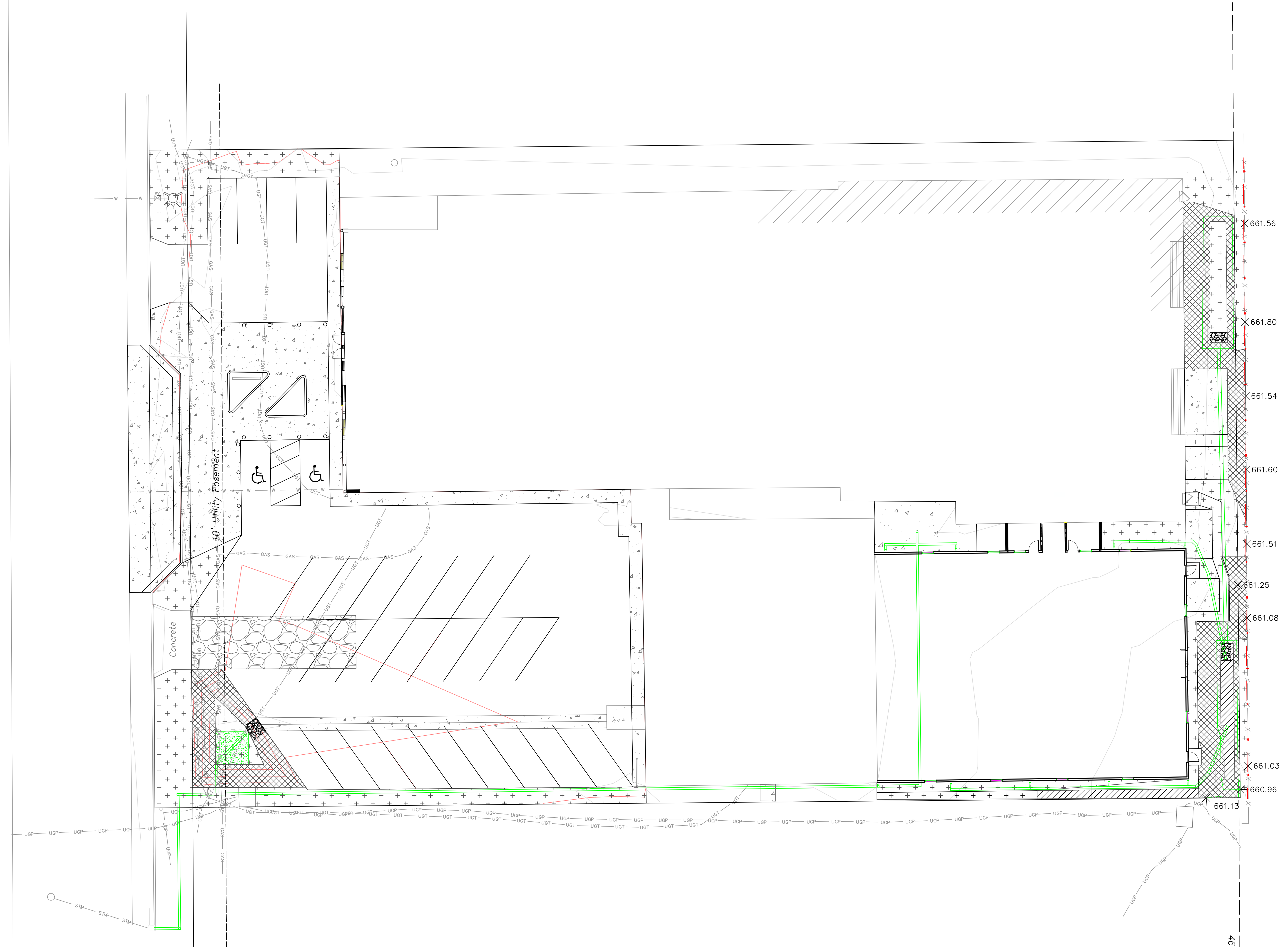

200 MASON STREET #15
 ONALASKA, WI 54650
 608.881.6030

PERFORMANCE ELITE GYMNASTICS
 2023 ADDITION
 CITY OF LA CROSSE
 LA CROSSE COUNTY

05/11/2023



EROSION CONTROL PLAN

DATE	REVISION	DESCR.	
			7
			8

SILT FENCE

GENERAL NOTES

DETAILS OF CONSTRUCTION NOT SHOWN ON THIS DRAWING SHALL CONFORM TO PERTINENT REQUIREMENTS OF THE STANDARD SPECIFICATIONS AND APPLICABLE SPECIAL PROVISIONS.

- ① HORIZONTAL BRACE REQUIRED WITH 2" X 4" WOODEN FRAME OR EQUIVALENT AT TOP OF POSTS.
- ② FOR MANUAL INSTALLATIONS THE TRENCH SHALL BE A MINIMUM OF 4" WIDE & 6" DEEP TO BURY AND ANCHOR THE GEOTEXTILE FABRIC. FOLD MATERIAL TO FIT TRENCH AND BACKFILL & COMPACT TRENCH WITH EXCAVATED SOIL.
- ③ WOOD POSTS SHALL BE A MINIMUM SIZE OF 1 1/2" X 1 1/2" OF OAK OR HICKORY.
- ④ SILT FENCE TO EXTEND ACROSS THE TOP OF THE PIPE.
- ⑤ CONSTRUCT SILT FENCE FROM A CONTINUOUS ROLL IF POSSIBLE BY CUTTING LENGTHS TO AVOID JOINTS. IF A JOINT IS NECESSARY USE ONE OF THE FOLLOWING TWO METHODS; A) OVERLAP THE END POSTS AND TWIST, OR ROTATE, AT LEAST 180 DEGREES, B) HOOK THE END OF EACH SILT FENCE LENGTH.

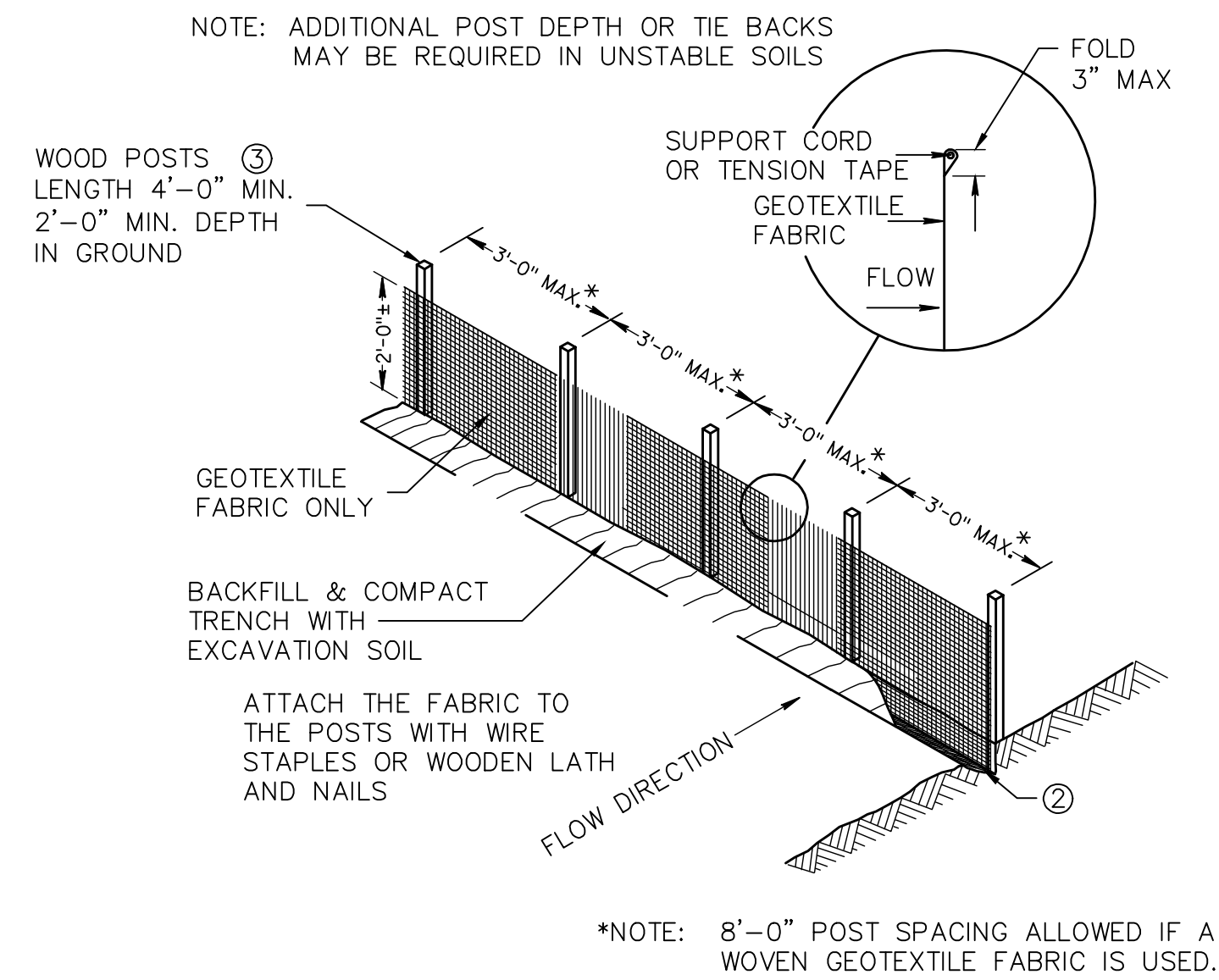
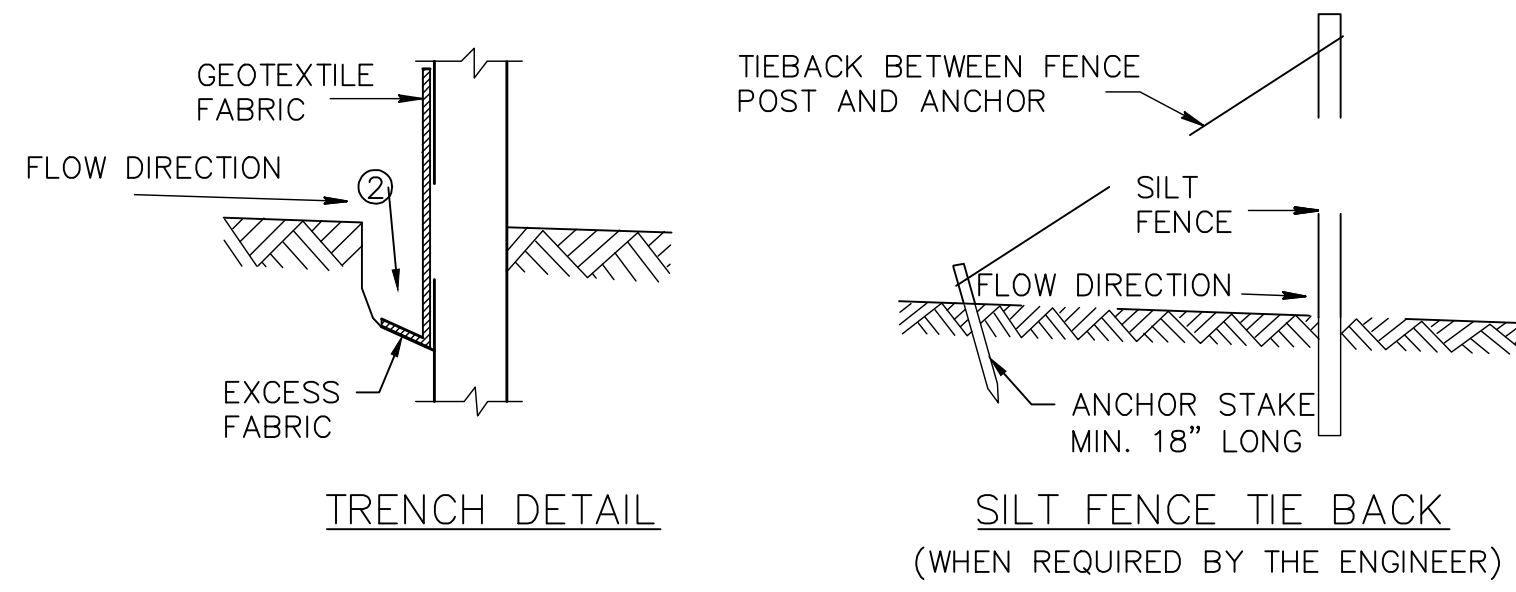

SILT FENCE

JOINING TWO LENGTHS OF SILT FENCE

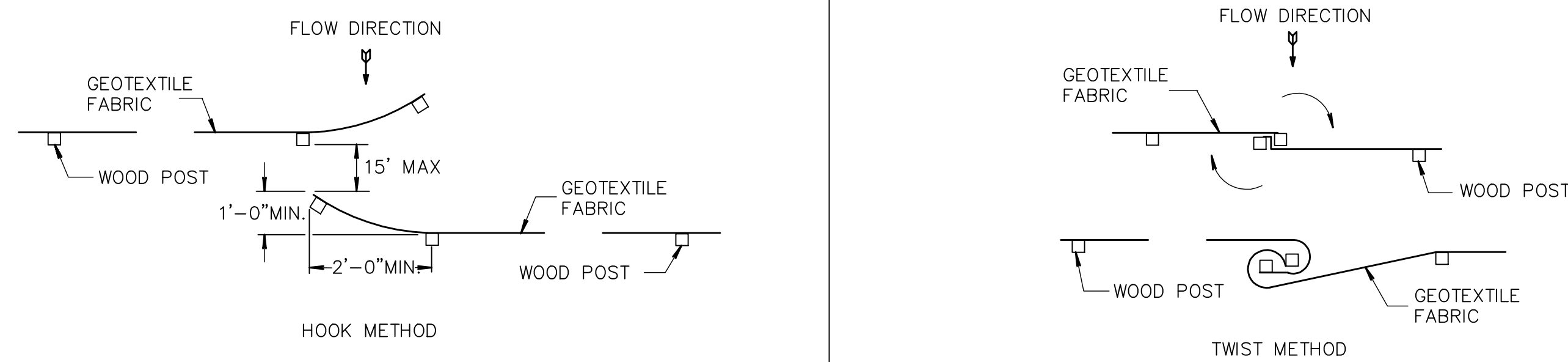

NON-CHANNEL EROSION MAT

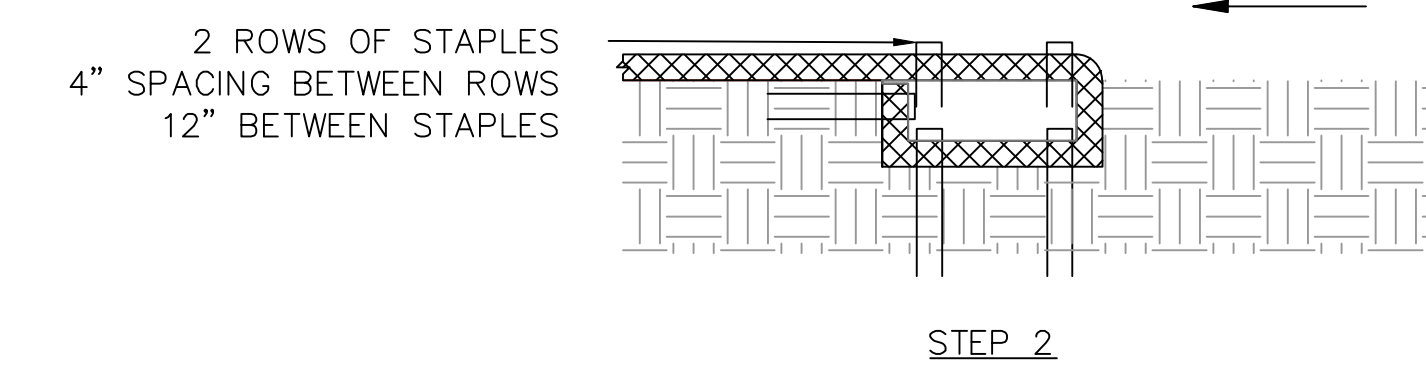
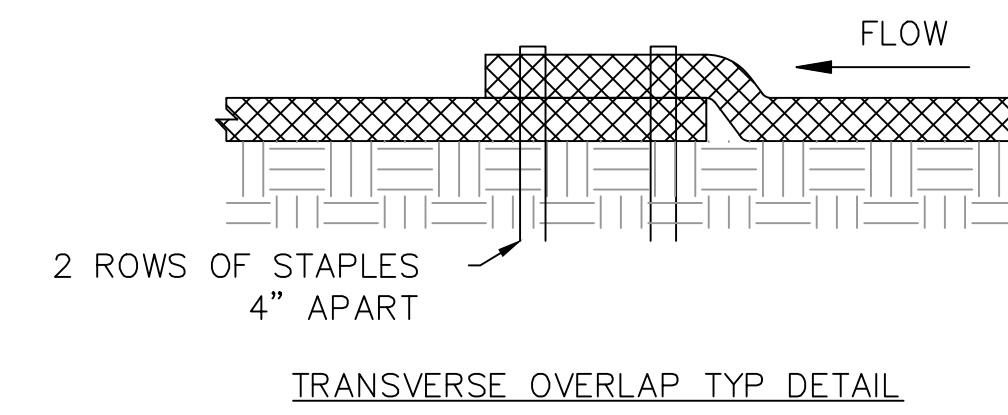
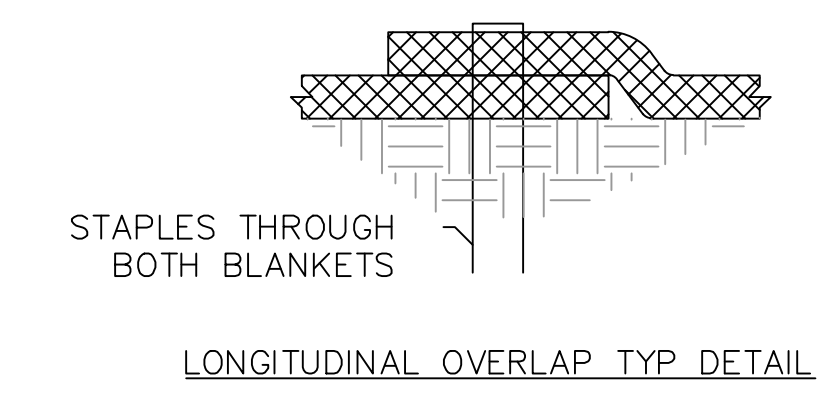
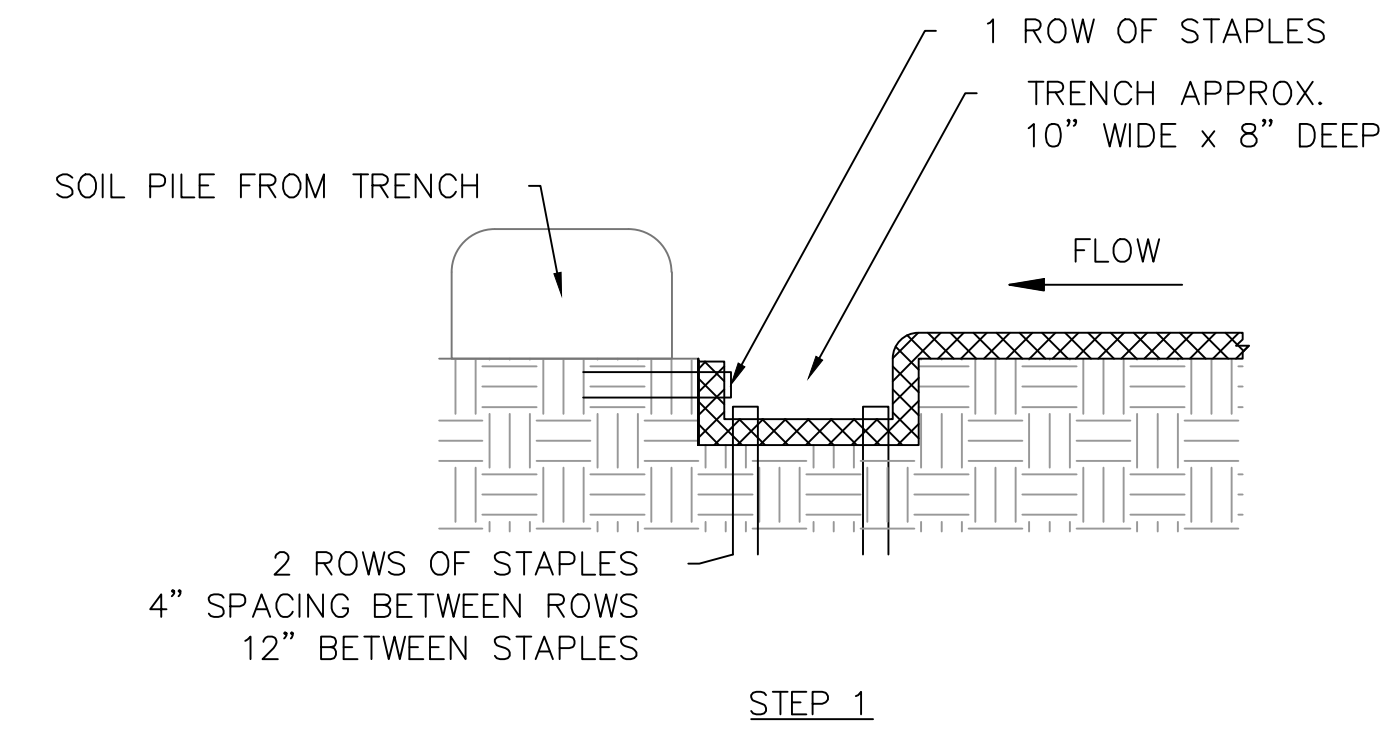

TOP EDGE TYP DETAIL

