

SEE A1.11 FOR ADDITIONAL ADA REQUIREMENTS

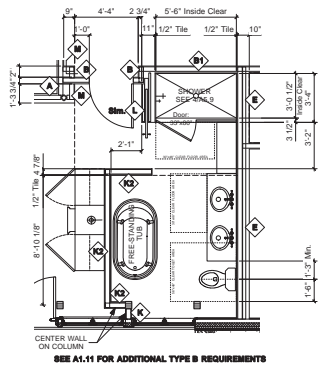

SEE A1.11 FOR ADDITIONAL TYPE B REQUIREMENTS

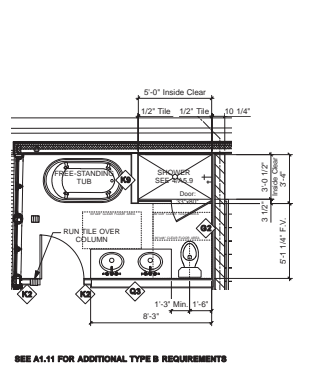

SEE A1.11 FOR ADDITIONAL TYPE B REQUIREMENTS

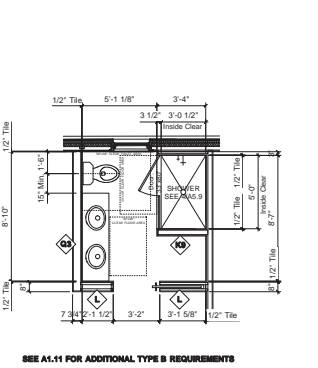

SEE A1.11 FOR ADDITIONAL TYPE B REQUIREMENTS

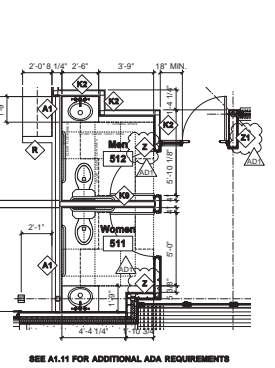

SEE A1.11 FOR ADDITIONAL ADA REQUIREMENTS

**6 BATHROOM PLAN - ADA**  
 SCALE: 1/4" = 1'-0" 1HR SHAFT

**5 BATHROOM PLAN - TYPE B**  
 SCALE: 1/4" = 1'-0"

**4 BATHROOM PLAN - TYPE B**  
 SCALE: 1/4" = 1'-0"

**3 BATHROOM PLAN - TYPE B**  
 SCALE: 1/4" = 1'-0"

**2 TOILET ROOM PLAN**  
 SCALE: 1/4" = 1'-0"

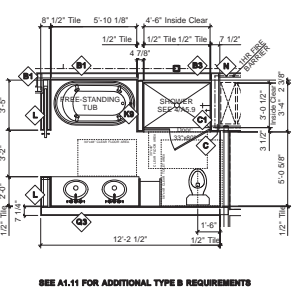

SEE A1.11 FOR ADDITIONAL TYPE B REQUIREMENTS

**7 BATHROOM PLAN - TYPE B**  
 SCALE: 1/4" = 1'-0" 1HR SHAFT

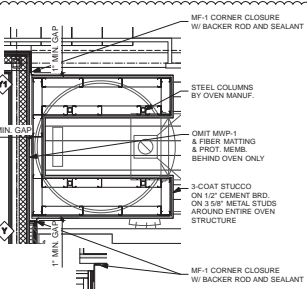
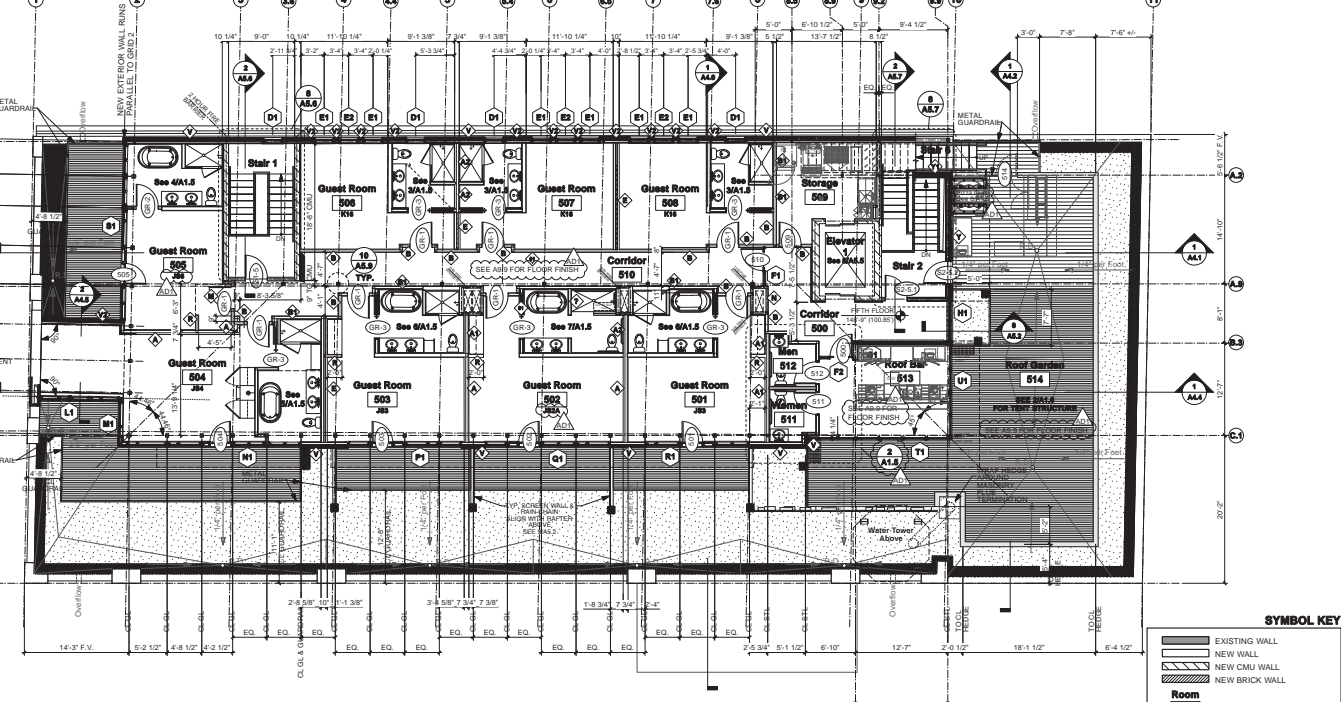

**8 PIZZA OVEN PLAN**  
 SCALE: 1/2" = 1'-0"

**KEY NOTES**

CORRIDORS INCLUDE:

FLOOR: WOOD FLOORING TO BE INSTALLED AS A BORDER W/ A NEW ACOUSTIC SEPARATION, NEW INSET CARPET RUNNER AND PAD DOWN EDGES. (OWNER FURNISHED, GC INSTALLED)

WALL: TYPE 2 VINYL WALLCOVERING

CEILING: PAINTED GYP BRD

DOOR: PAINTED LACQUERED WOOD DOORS W/ RAISED MOLDING DETAIL, OIL RUBBED BRONZE DOOR HARDWARE

**1 FIFTH FLOOR PLAN**  
 SCALE: 1/8" = 1'-0"

**GENERAL NOTES**

- REFER TO SPECIFIC ROOM TYPE DRAWINGS FOR FURTHER INFORMATION.
- PROVIDE 30 MINUTE FIRE PARTITION BETWEEN ADJACENT DWELLING UNITS, AND BETWEEN DWELLING UNITS AND PUBLIC SPACE.
- WHERE FIRE RATED WALLS INTERSECT NON-RATED WALLS, THE RATED WALL ASSEMBLY SHOULD RUN UNINTERRUPTED.
- ALL NEW WALLS ARE PARALLEL OR PERPENDICULAR TO THE EXISTING SOUTH WALL (GRID D) UNLESS NOTED OTHERWISE.
- GRIDS A.2, A.3, B.3, C.1, 8.5, 8.9, 9.1, 9.2, & 9.9 ARE PARALLEL OR PERPENDICULAR TO GRID D.
- GRID 9.9 IS CENTERED ON THE INTERSECTION OF GRIDS C, 1, & 10.
- ALL NEW STEEL COLUMNS & BEAMS IN EXTERIOR WALLS TO BE 300R RATED WITH PNT2. INCLUDES COLUMNS AND ISLES ON GRID 9.1 & 9.2.



**SYMBOL KEY**

[Pattern]	EXISTING WALL
[Pattern]	NEW WALL
[Pattern]	NEW CMU WALL
[Pattern]	NEW BRICK WALL
Room XXX	ROOM NAME & NUMBER
K1	GUEST ROOM TYPE
(S)	STRUCTURAL GRID LINE
(X)	WINDOW TYPE (SEE A6.0)
(W)	WALL TYPE (SEE A5.0)
(D)	DOOR NUMBER (SEE A6.5)
[Pattern]	RECYCLED WOOD FLOOR
[Pattern]	CARPET

## FIFTH FLOOR & FINISH PLAN

# A1.5