

PLAN SHEET DISCLAIMER:

1. EVERY REASONABLE EFFORT HAS BEEN MADE TO ASSURE THE ACCURACY OF THESE PLANS AND ASSOCIATED DATA.
2. IN AN EFFORT TO INCREASE THE CLARITY AND LEGIBILITY OF THE PLANS, EXISTING UNDERGROUND UTILITIES WILL NOT BE SHOWN UNLESS THERE IS PROPOSED WORK THAT WILL REQUIRE EXCAVATION OR ANY OTHER EARTH DISTURBING ACTIVITY. IF PROPOSED WORK WILL REQUIRE THIS TYPE OF ACTIVITY, EXISTING UNDERGROUND UTILITIES WILL BE PROPERLY INVESTIGATED AND REPRESENTED ON THE PLAN SHEET OF THE RESPECTIVE WORK LOCATION

UTILITIES

1. THE IDENTITY AND LOCATION OF EXISTING UNDERGROUND UTILITIES LOCATED IN AND AROUND THE CONSTRUCTION AREA HAVE BEEN SHOWN AND LABELED ON THE PLANS BY USING INFORMATION PROVIDED BY THE RESPECTIVE UTILITY OWNERS.
2. SUPPORT AND PROTECTION OF ALL UTILITIES AND APPURTENANCES SHALL BE THE RESPONSIBILITY OF THE CONTRACTOR. COSTS FOR THE REPAIR AND RESTORATION OF EXISTING UTILITIES DAMAGED BY THE CONTRACTOR SHALL BE THE RESPONSIBILITY OF THE CONTRACTOR
3. CALL 811 BEFORE YOU DIG. AT LEAST 48 HOURS PRIOR TO EXCAVATION.

WORK LIMITS

1. THE WORK LIMITS SHOWN ON THESE PLANS ARE FOR PHYSICAL CONSTRUCTION ONLY. THE INSTALLATION AND OPERATION OF ALL TEMPORARY TRAFFIC CONTROL AND TEMPORARY TRAFFIC CONTROL DEVICES REQUIRED BY THESE PLANS SHALL BE PROVIDED BY THE CONTRACTOR WHETHER INSIDE OR OUTSIDE OF THESE WORK LIMITS.

MAINTAIN DRAINAGE

1. THE CONTRACTOR AT HIS OWN EXPENSE, SHALL MAINTAIN THE FLOW IN ALL SEWERS, DRAINS, FIELD TILES, AND WATERCOURSES ENCOUNTERED IN AND AROUND THE PROJECT SITE. IF SUCH WATERCOURSES OR DRAINS ARE DISTURBED OR DESTROYED DURING THE EXECUTION OF THE PROJECT, THEY SHALL BE RESTORED BY THE CONTRACTOR AT HIS OWN EXPENSE TO A CONDITION SATISFACTORY TO THE ENGINEER.

SECURING EXCAVATIONS & TRENCHES FOR NON-WORKING HOURS

1. EXCAVATIONS AND TRENCHES OVER 24-INCHES DEEP SHALL BE SECURELY PLATED OR BACKFILLED DURING NON-WORKING HOURS.

EXCAVATION OF ROADWAY AND RIGHT-OF-WAY AREAS

1. ANY CONTRACTOR PERFORMING EXCAVATION, INCLUDING BUT NOT LIMITED TO DISTURBING THE EARTH WITH POWERED OR NON-POWERED EQUIPMENT, DRILLING AND/OR BORING, SHALL CAUSE NOTICE TO BE GIVEN BY CALLING 811 AT LEAST 48 HOURS BUT NOT MORE THAN 10 WORKING DAYS BEFORE EXCAVATING.
2. THE EXCAVATOR SHALL PROTECT AND PRESERVE THE MARKINGS UNTIL THOSE MARKINGS ARE NO LONGER NEEDED. IF AN EXCAVATION WILL COVER A LARGE AREA AND/OR PROGRESS FROM ONE AREA TO THE NEXT OVER A PERIOD OF TIME, THE EXCAVATOR SHALL COORDINATE THE MARKING OF APPROXIMATE LOCATIONS OF CITY OWNED FACILITIES WITH THE ACTUAL EXCAVATION.
3. THE CONTRACTOR IS RESPONSIBLE FOR LOCATING ALL CUSTOMER OWNED SERVICE LINES/LATERALS. THE CONTRACTOR SHALL FIELD VERIFY THE HORIZONTAL AND VERTICAL LOCATION OF ANY CITY OR CUSTOMER OWNED MAIN OR SERVICE LINE/LATERALS THAT MAY BE AFFECTED BY THE PROPOSED CONSTRUCTION ACTIVITIES. FIELD VERIFICATION SHALL TAKE PLACE PRIOR TO ANY ACTIVITY THAT MAY JEOPARDIZE THE INTEGRITY OF THE FACILITY AND AT A LOCATION NEAREST THE POINT OF POSSIBLE CONFLICT.
4. ANY DAMAGES TO CITY OR CUSTOMER OWNED FACILITIES SHOULD FIRST BE REPORTED TO THE UTILITY OWNER THEN IMMEDIATELY NOTIFY THE PROJECT ENGINEER.

AERIAL CONSTRUCTION:

1. CONTRACTOR TO VERIFY ALL BONDING AND GROUNDING COMPLES WITH NESC GUIDELINES.
2. CONSTRUCTION TO VERIFY ALL REQUIRED MAKE READY WORK IS COMPLETE BEFORE PLACING ON UTILITY POLES.

SAFETY NOTE:

1. CHECK IN WITH CONSTRUCTION SUPERVISOR WHEN ARRIVING ON-SITE.
2. HEAVY CONSTRUCTION EQUIPMENT IN USE. BEWARE OF SURROUNDINGS.
3. FOLLOW CONGRUEX SAFETY POLICIES AND GUIDELINES AT ALL TIMES WHILE WORKING.
4. CONSTRUCTION ZONE/ HARD HAT, SAFETY GLASSES, REFLECTIVE VEST/SHIRT, SAFETY TOE BOOTS REQUIRED – WORK SAFELY

EXISTING EQUIPMENTS LEGENDS

	R/W		CABINET		ELECTRIC TRANSFORMER		GAS METER		CULVERT
	CENTER LINE		EXISTING PED		ELECTRIC METER		GAS VALVE		C/L MONUMENT
	EOP		EXISTING FLOWERPOT		ELECTRIC VAULT/HANDHOLE		SEWER MANHOLE		ANCHOR & DOWN GUY
	BOC		EXISTING HANDHOLE		ELECTRIC MANHOLE		UNKNOWN MANHOLE		
	PROPERTY LINE		TELEPHONE CABINET		EXISTING VAULT		WATER METER		
	FENCE		TELEPHONE MANHOLE		STREETLIGHT		WATER VALVE		
	TELCO		POLE		POWER PED		FIRE HYDRANT		
	ELECTRIC		CABLE MARKER		CATV PED		WATER MANHOLE		
	GAS		STREET SIGN		CATV VAULT/HANDHOLE		STORM DRAIN CATCH BASIN		
	TRAFFIC SIGNAL		VERTICAL GROUND		TREE		STORM DRAIN MANHOLE		
	WATER		ELECTRIC PEDESTAL/CABINET		TRANSFORMER				
	SEWER								
	STORM DRAIN								
	UTILITY EASEMENT								
	RAIL TRACKS								
	SIDEWALK								

PROPOSED EQUIPMENTS LEGENDS

	BORE		12"X24"X18" HANDHOLE
	TRENCH		17"X30"X18" HANDHOLE
	AERIAL FIBER		24"X36"X24" HANDHOLE
	AERIAL STRAND		36"X48"X30" HANDHOLE
			ANCHOR & DOWN GUY

MINIMUM STANDARDS FOR DIRECTIONAL BORING
STREET CROSSINGS

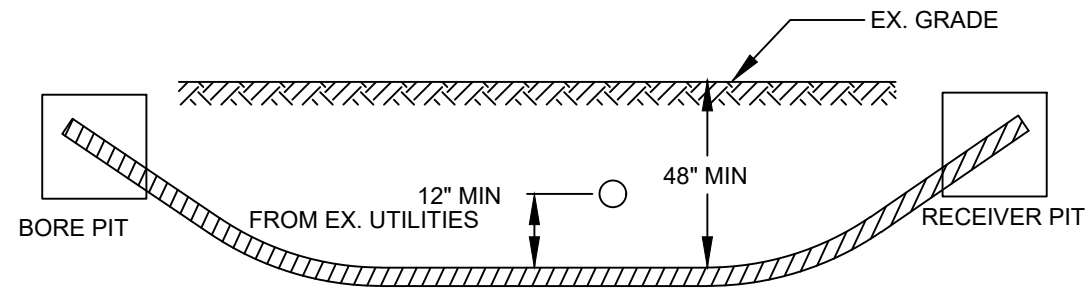

- PLACE END MARKER WITH UTILITY OWNER'S NAME DESCRIBING CONDUIT
- BORE PIT TO BE BACKFILLED AND COMPACTED IN 12" LIFTS WITH MATERIAL REMOVED
- FLOW OF DITCH MUST BE MAINTAINED AT ALL TIMES
- PROTECT ROOTS AT ALL TREE LOCATIONS, SHIFT BORE TRENCH IF NECESSARY

TYPICAL BORE DETAILS 1

MINIMUM STANDARDS FOR DIRECTIONAL BORING
UNDER SIDEWALKS & WITHIN ROW (EXCLUDING STREET CROSSINGS)

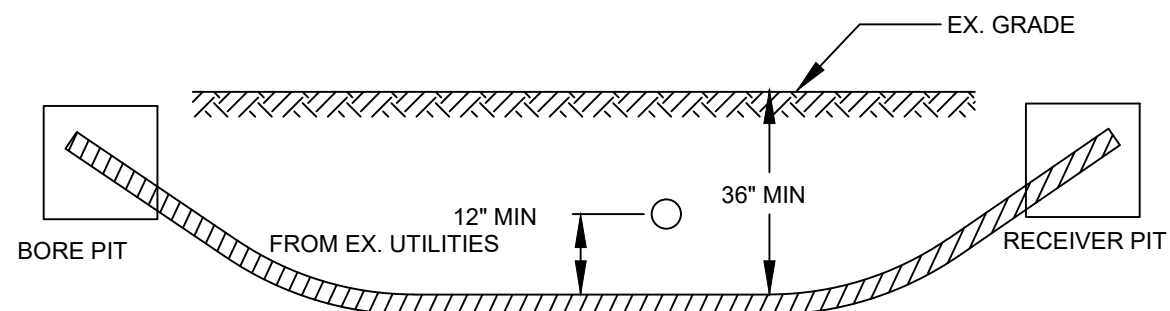

- PLACE END MARKER WITH UTILITY OWNER'S NAME DESCRIBING CONDUIT
- BORE PIT TO BE BACKFILLED AND COMPACTED IN 12" LIFTS WITH MATERIAL REMOVED
- FLOW OF DITCH MUST BE MAINTAINED AT ALL TIMES
- PROTECT ROOTS AT ALL TREE LOCATIONS, SHIFT BORE TRENCH IF NECESSARY

TYPICAL BORE DETAILS 2

PLAN VIEW

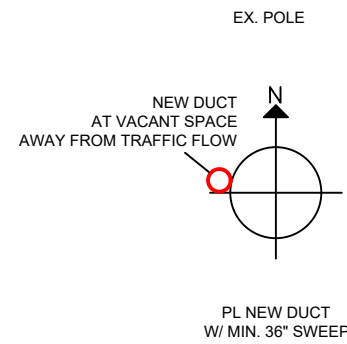

ELEVATION

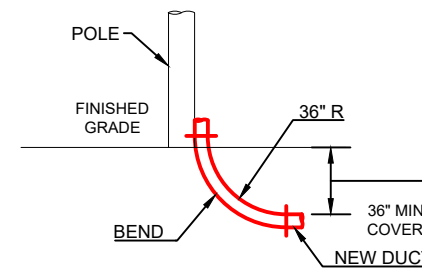

RISER DETAILS

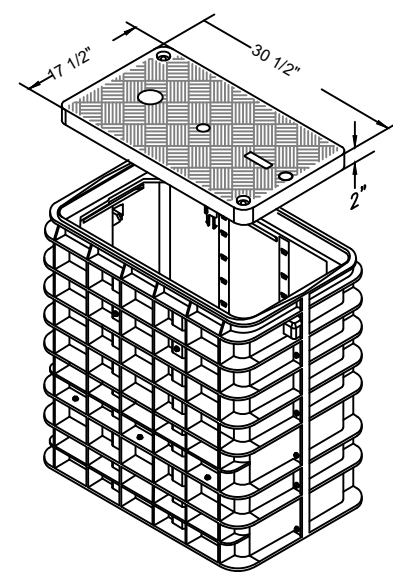

17"x30"x18"
N.T.S.

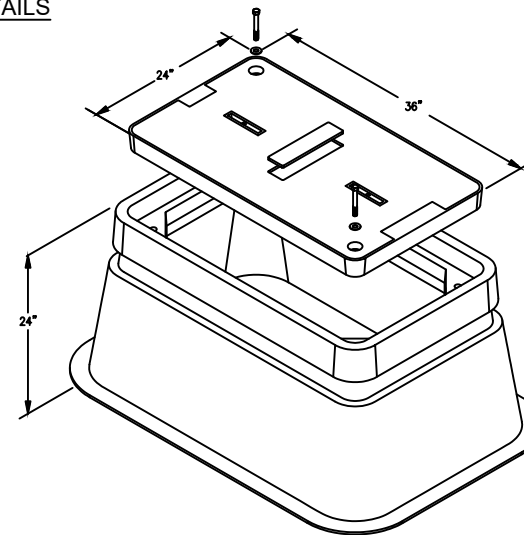

24"x36"x24"
N.T.S.

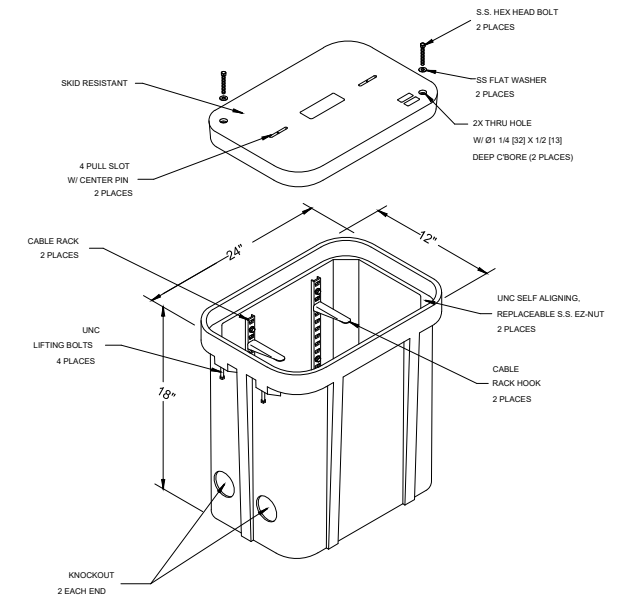

12"x24"x18"
N.T.S.

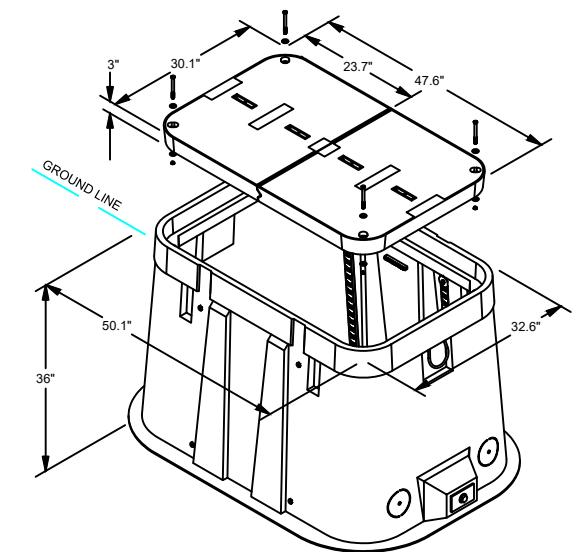

30"x48"x36"
N.T.S.

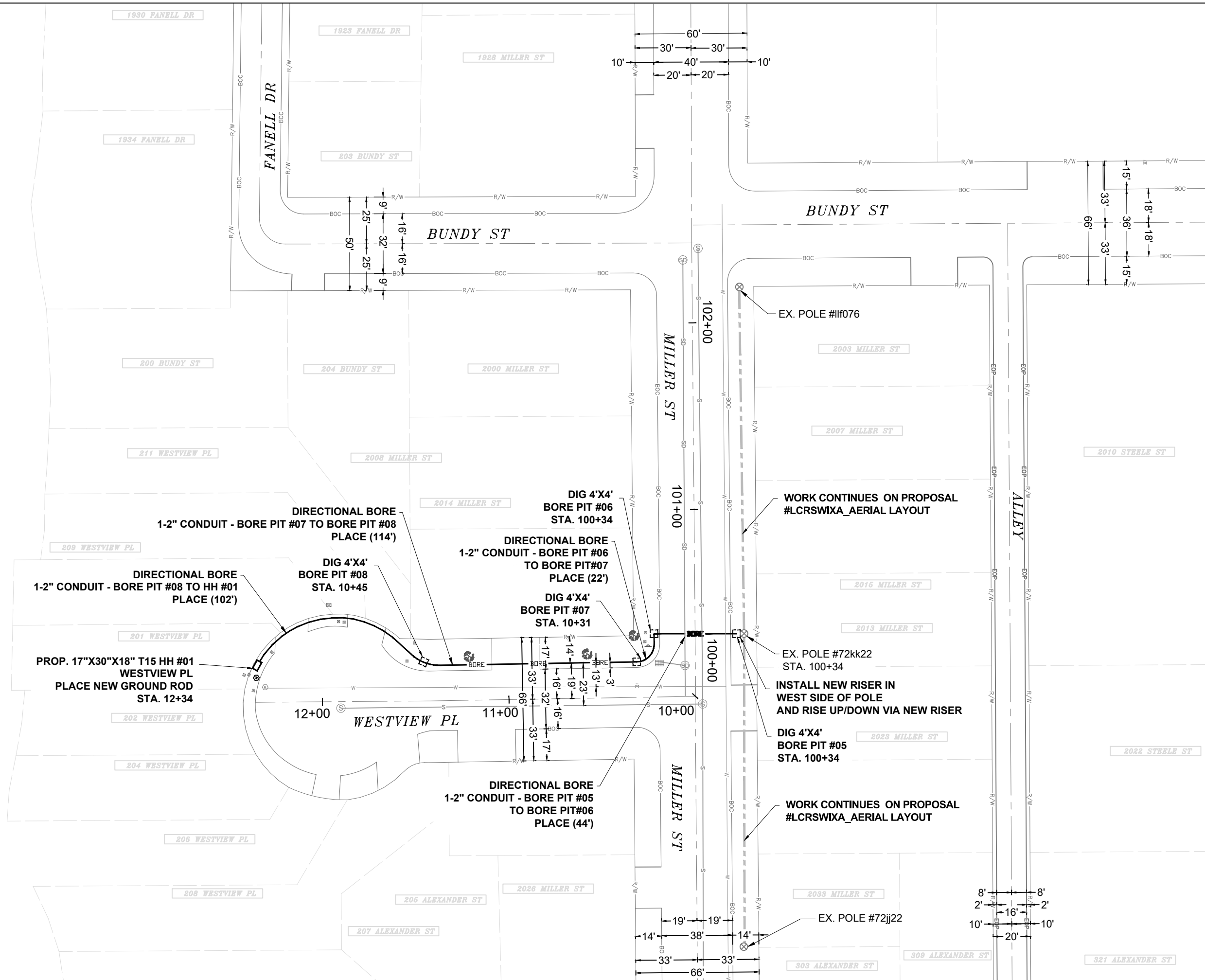
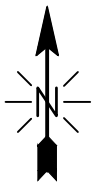

EXCAVATION DATA	
PROPOSED UTILITY	DIRT
(4) BORE PIT 4'X4'	64 SQFT

CALL 811 BEFORE YOU DIG.
WISCONSIN TOLL FREE
800-242-8511



CONFIDENTIAL AND PROPRIETARY
LCRSWIXC