

# RED CLOUD DEVELOPMENT APARTMENT BUILDING

LA CROSSE, WISCONSIN



1 EXTERIOR PERSPECTIVE - FRONT



2 EXTERIOR PERSPECTIVE - BACK

## COVER SHEET



UNIT MATRIX					
	STUDIO	1 BEDROOM	2 BEDROOM	TOTAL	SQUARE FOOTAGE
5TH FLOOR	6	7	5	18	17,102 SQ. FT.
4TH FLOOR	6	7	5	18	17,017 SQ. FT.
3RD FLOOR	6	7	5	18	17,017 SQ. FT.
2ND FLOOR	6	7	5	18	17,017 SQ. FT.
GROUND/PARKING	-	-	-	-	16,175 SQ. FT.
<b>TOTAL</b>	<b>24</b>	<b>28</b>	<b>20</b>	<b>72</b>	<b>84,328 SQ. FT.</b>

LOWER LEVEL PARKING: 42 STALLS

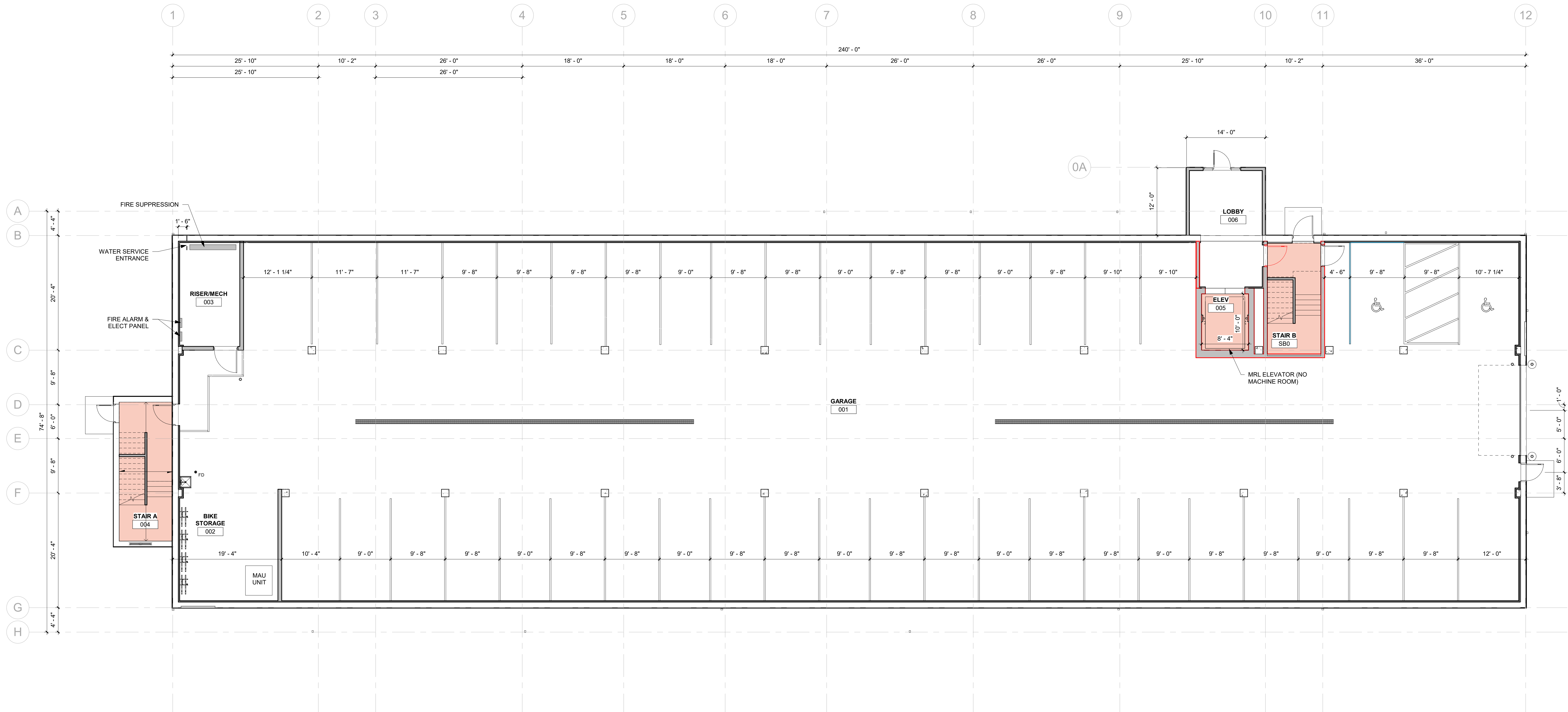

GROUND/PARKING FLOOR PLAN



UNIT MATRIX					
	STUDIO	1 BEDROOM	2 BEDROOM	TOTAL	SQUARE FOOTAGE
5TH FLOOR	6	7	5	18	17,102 SQ. FT.
4TH FLOOR	6	7	5	18	17,017 SQ. FT.
3RD FLOOR	6	7	5	18	17,017 SQ. FT.
2ND FLOOR	6	7	5	18	17,017 SQ. FT.
GROUND/PARKING	-	-	-	-	16,175 SQ. FT.
<b>TOTAL</b>	<b>24</b>	<b>28</b>	<b>20</b>	<b>72</b>	<b>84,328 SQ. FT.</b>

LOWER LEVEL PARKING: 42 STALLS

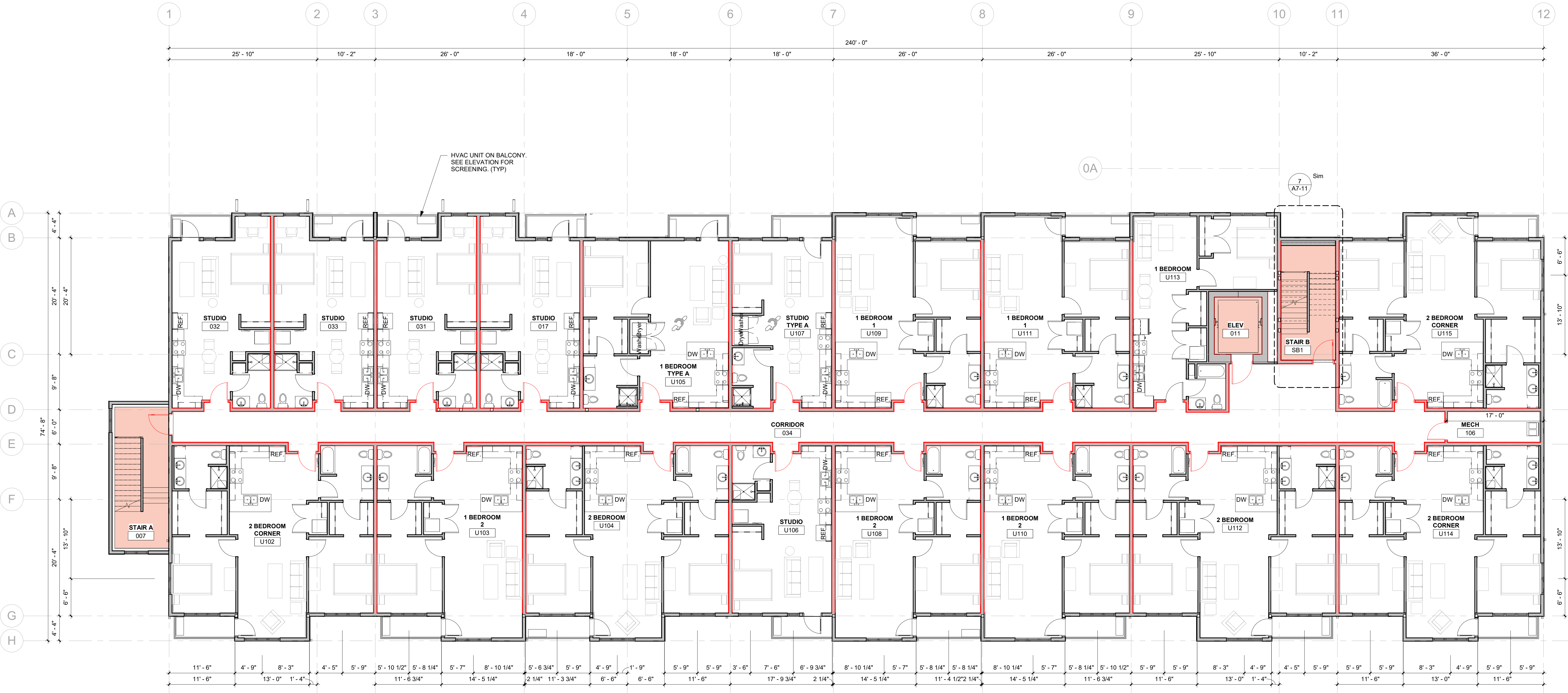

SECOND FLOOR PLAN



UNIT MATRIX					
	STUDIO	1 BEDROOM	2 BEDROOM	TOTAL	SQUARE FOOTAGE
5TH FLOOR	6	7	5	18	17,102 SQ. FT.
4TH FLOOR	6	7	5	18	17,017 SQ. FT.
3RD FLOOR	6	7	5	18	17,017 SQ. FT.
2ND FLOOR	6	7	5	18	17,017 SQ. FT.
GROUND/PARKING	-	-	-	-	16,175 SQ. FT.
<b>TOTAL</b>	<b>24</b>	<b>28</b>	<b>20</b>	<b>72</b>	<b>84,328 SQ. FT.</b>

LOWER LEVEL PARKING: 42 STALLS

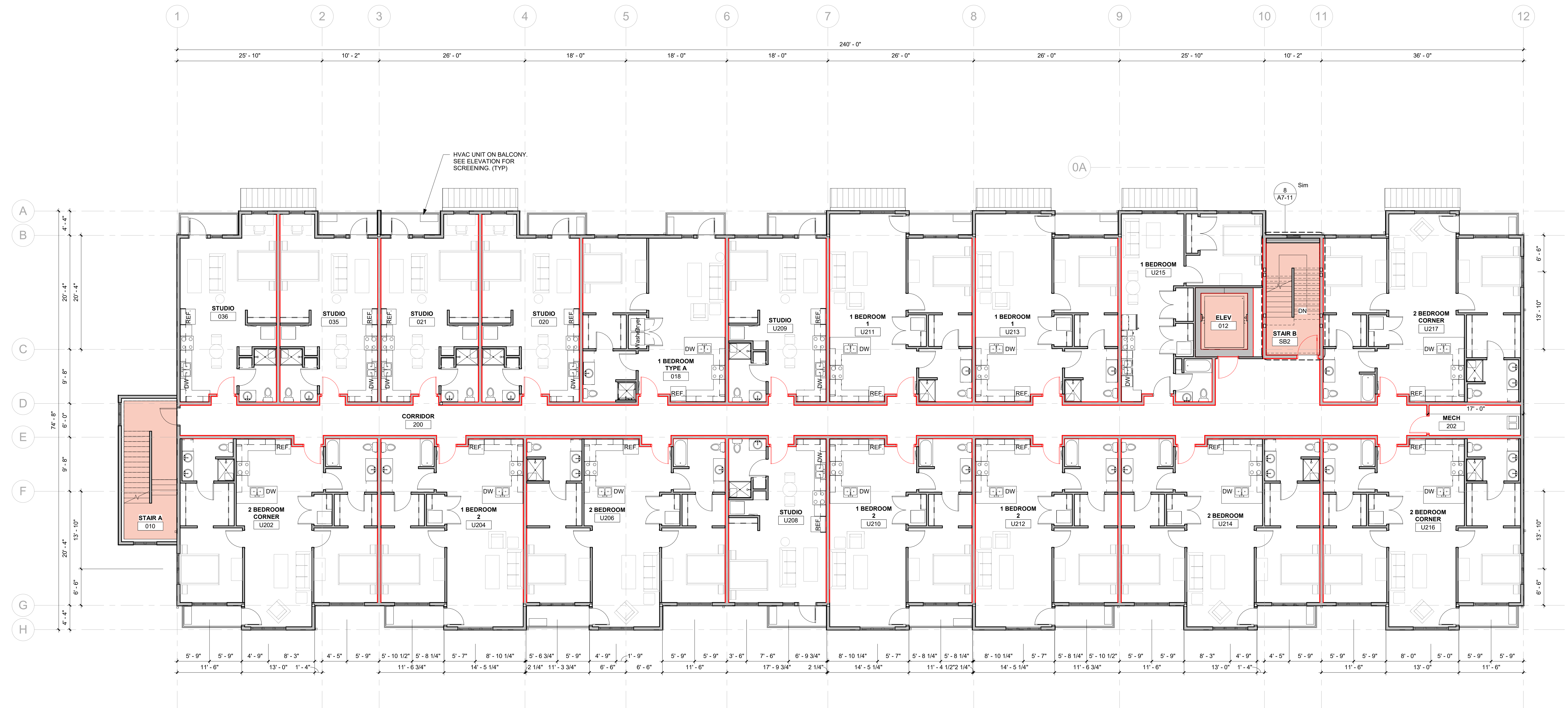

THIRD FLOOR PLAN





UNIT MATRIX					
	STUDIO	1 BEDROOM	2 BEDROOM	TOTAL	SQUARE FOOTAGE
5TH FLOOR	6	7	5	18	17,102 SQ. FT.
4TH FLOOR	6	7	5	18	17,017 SQ. FT.
3RD FLOOR	6	7	5	18	17,017 SQ. FT.
2ND FLOOR	6	7	5	18	17,017 SQ. FT.
GROUND/PARKING	-	-	-	-	16,175 SQ. FT.
<b>TOTAL</b>	<b>24</b>	<b>28</b>	<b>20</b>	<b>72</b>	<b>84,326 SQ. FT.</b>

LOWER LEVEL PARKING: 42 STALLS

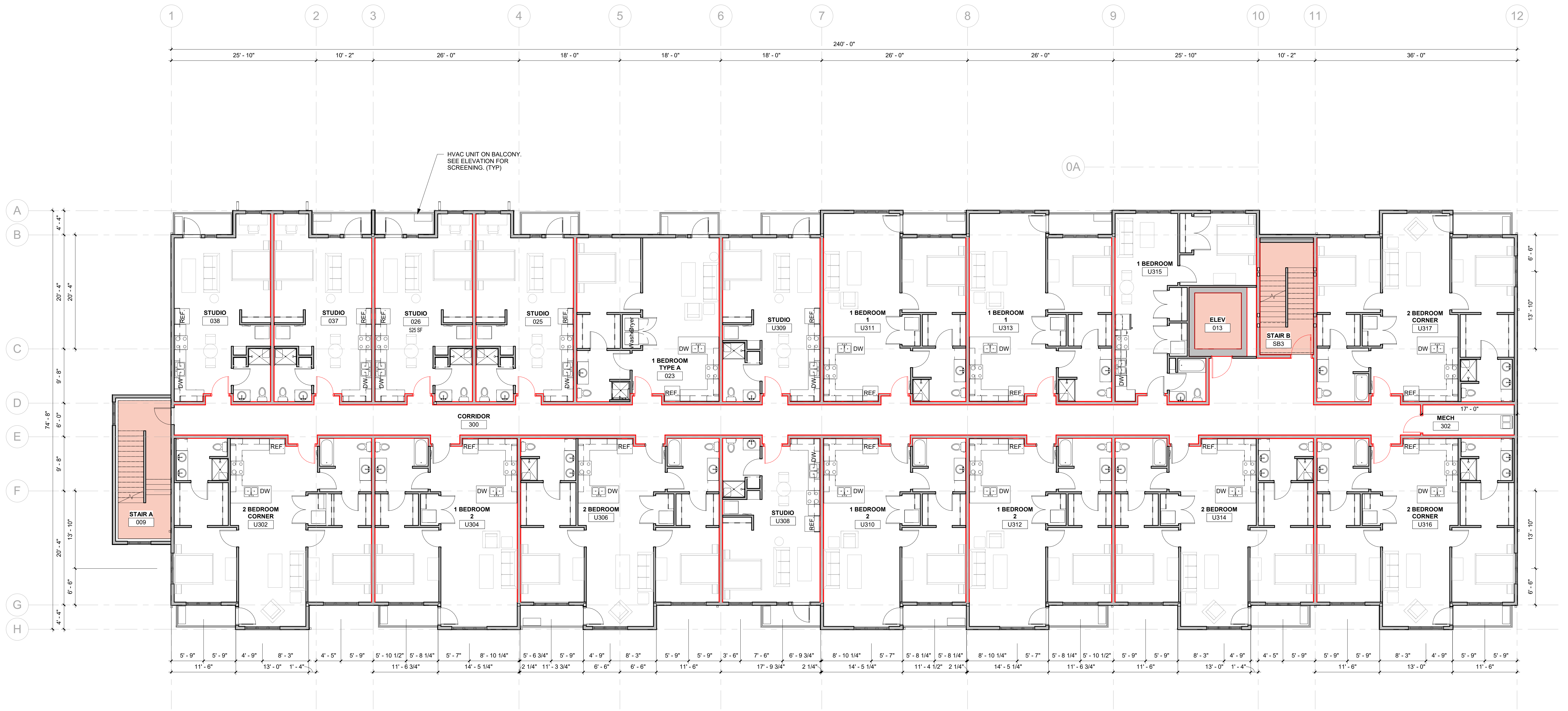

FOURTH FLOOR PLAN



UNIT MATRIX					
	STUDIO	1 BEDROOM	2 BEDROOM	TOTAL	SQUARE FOOTAGE
5TH FLOOR	6	7	5	18	17,102 SQ. FT.
4TH FLOOR	6	7	5	18	17,017 SQ. FT.
3RD FLOOR	6	7	5	18	17,017 SQ. FT.
2ND FLOOR	6	7	5	18	17,017 SQ. FT.
GROUND/PARKING	-	-	-	-	16,175 SQ. FT.
<b>TOTAL</b>	<b>24</b>	<b>28</b>	<b>20</b>	<b>72</b>	<b>84,328 SQ. FT.</b>

LOWER LEVEL PARKING: 42 STALLS

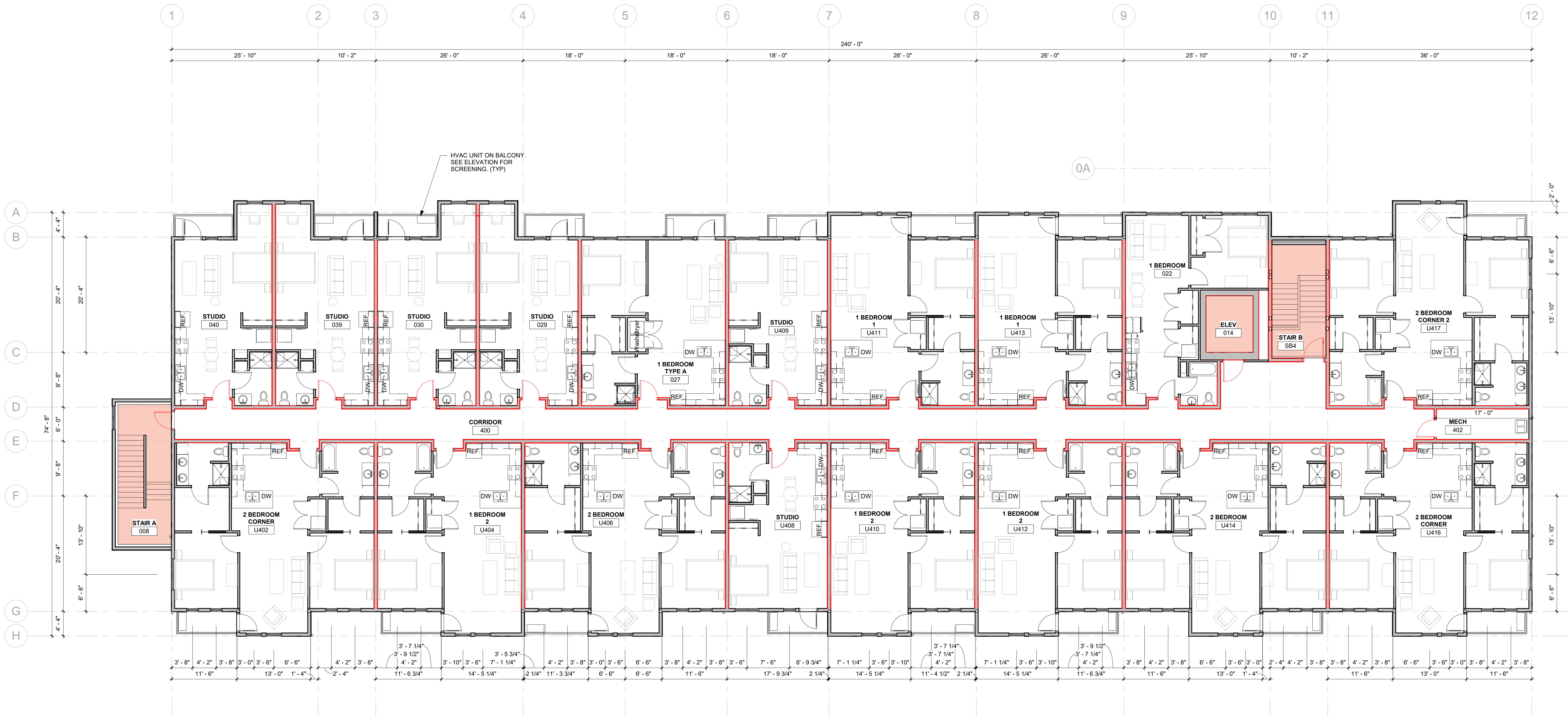

FIFTH FLOOR PLAN





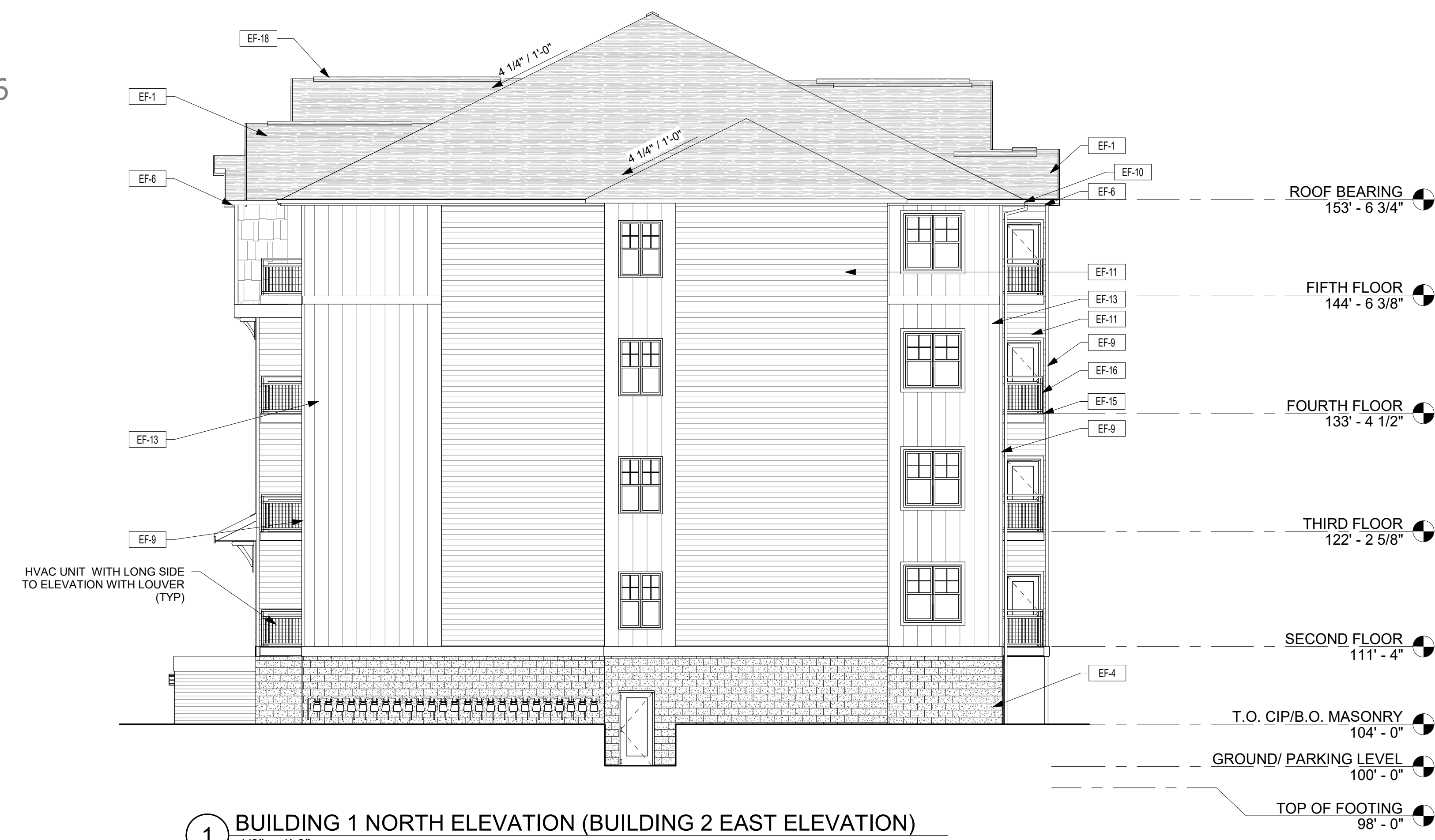

1 BUILDING 1 NORTH ELEVATION (BUILDING 2 EAST ELEVATION)  
1/8" = 1'-0"

EXTERIOR FINISH SCHEDULE						
MARK	MATERIAL TYPE	MANUFACTURER	SERIES	SIZE	COLOR	COMMENTS
EF-1	TEXTURED FIBERGLASS SHINGLES					
EF-2	SHAKES SIDING	LP SMARTSIDE				
EF-3						
EF-4	DECORATIVE CMU	COUNTY MATERIALS		8" X 16"		
EF-5	ACCENT BRACKET					
EF-6	ROOF EDGE FASCIA	ROLLEX				
EF-7	TRIM			1X10		
EF-8	TEXTURED PLANK	LP SMARTSIDE				
EF-9	TRIM	LP SMARTSIDE		1X4		
EF-10	GUTTERS AND DOWNSPOUTS					
EF-11	LAP SIDING	LP SMARTSIDE				
EF-12	METAL ROOFING	M-COR				
EF-13	BOARD AND BATTEN	LP SMARTSIDE				
EF-14	ALUMINUM VENTED SOFFIT	ROLLEX	FULLY VENTED SOFFIT AT EAVES SOLID SOFFIT AT RAKES	16"		CLEAR AREA: 12.96 SQ IN PER LINEAL FOOT
EF-15	DECKING AND FASCIA BOARD	TREX				
EF-16	PREFINISHED METAL GUARDRAIL					REFER TO STRUCTURAL NOTES FOR RAILING DESIGN LOADS
EF-17	STAIN					
EF-18	RIDGE VENT	COR-A-VENT	V-600 RIDGE VENT			CLEAR AREA: 20 SQ IN PER LINEAL FOOT
EF-19	ROOF VENT	COR-A-VENT	ROOF-2-WALL VENT			



2 BUILDING 1 EAST ELEVATION (BUILDING 2 SOUTH ELEVATION)  
1/8" = 1'-0"

EXTERIOR ELEVATIONS





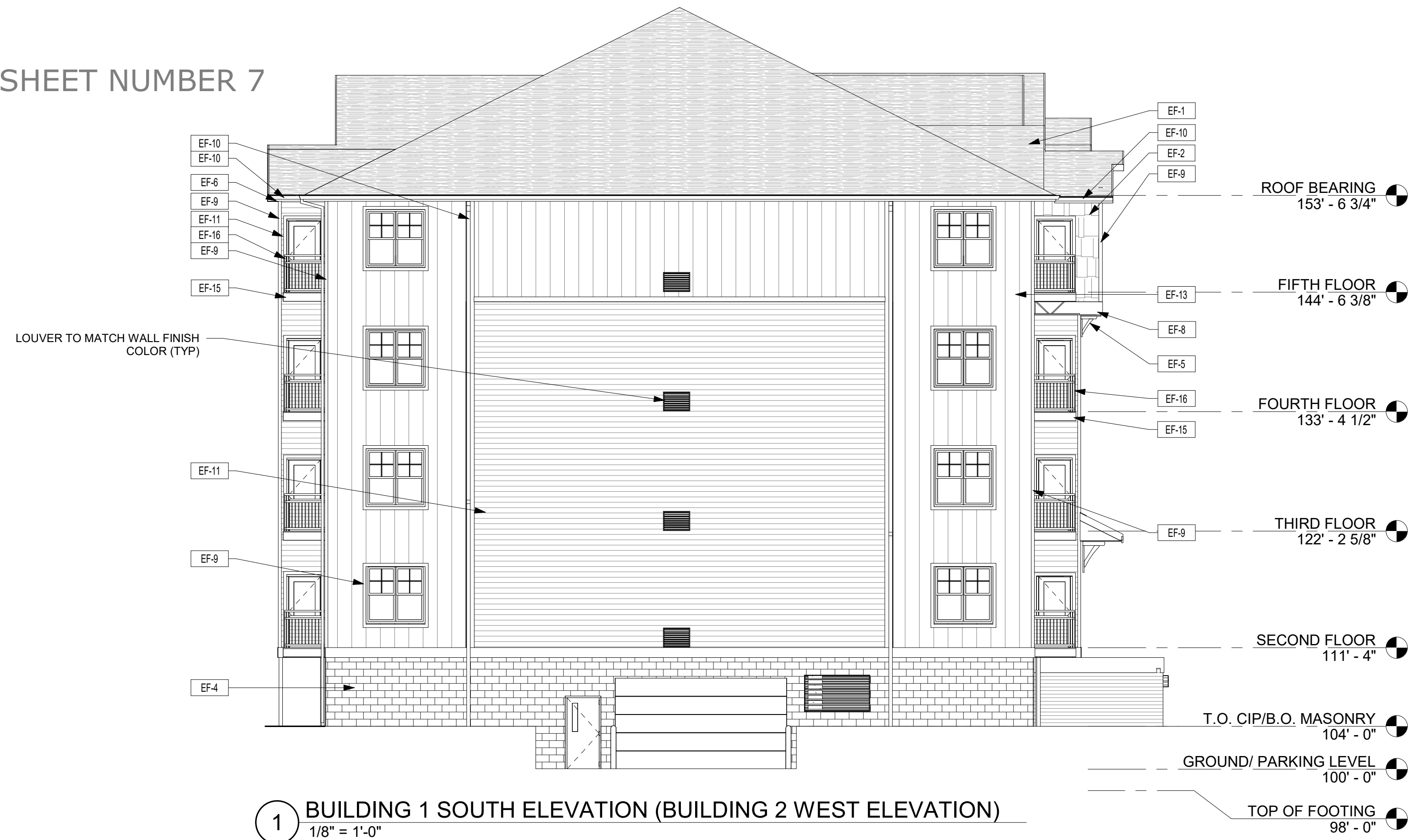

1 BUILDING 1 SOUTH ELEVATION (BUILDING 2 WEST ELEVATION)  
1/8" = 1'-0"

EXTERIOR FINISH SCHEDULE						
MARK	MATERIAL TYPE	MANUFACTURER	SERIES	SIZE	COLOR	COMMENTS
EF-1	TEXTURED FIBERGLASS SHINGLES					
EF-2	SHAKES SIDING	LP SMARTSIDE				
EF-3						
EF-4	DECORATIVE CMU	COUNTY MATERIALS		8" X 16"		
EF-5	ACCENT BRACKET					
EF-6	ROOF EDGE FASCIA	ROLLEX				
EF-7	TRIM			1X10		
EF-8	TEXTURED PLANK	LP SMARTSIDE				
EF-9	TRIM	LP SMARTSIDE		1X4		
EF-10	GUTTERS AND DOWNSPOUTS					
EF-11	LAP SIDING	LP SMARTSIDE				
EF-12	METAL ROOFING	M-COR				
EF-13	BOARD AND BATTEN	LP SMARTSIDE				
EF-14	ALUMINUM VENTED SOFFIT	ROLLEX	FULLY VENTED SOFFIT AT EAVES SOLID SOFFIT AT RAKES	16"		CLEAR AREA: 12.96 SQ IN PER LINEAL FOOT
EF-15	DECKING AND FASCIA BOARD	TREX				
EF-16	PREFINISHED METAL GUARDRAIL					REFER TO STRUCTURAL NOTES FOR RAILING DESIGN LOADS
EF-17	STAIN					
EF-18	RIDGE VENT	COR-A-VENT	V-600 RIDGE VENT			CLEAR AREA: 20 SQ IN PER LINEAL FOOT
EF-19	ROOF VENT	COR-A-VENT	ROOF-2-WALL VENT			



2 BUILDING 1 WEST ELEVATION (BUILDING 2 NORTH ELEVATION)  
1/8" = 1'-0"

EXTERIOR ELEVATIONS



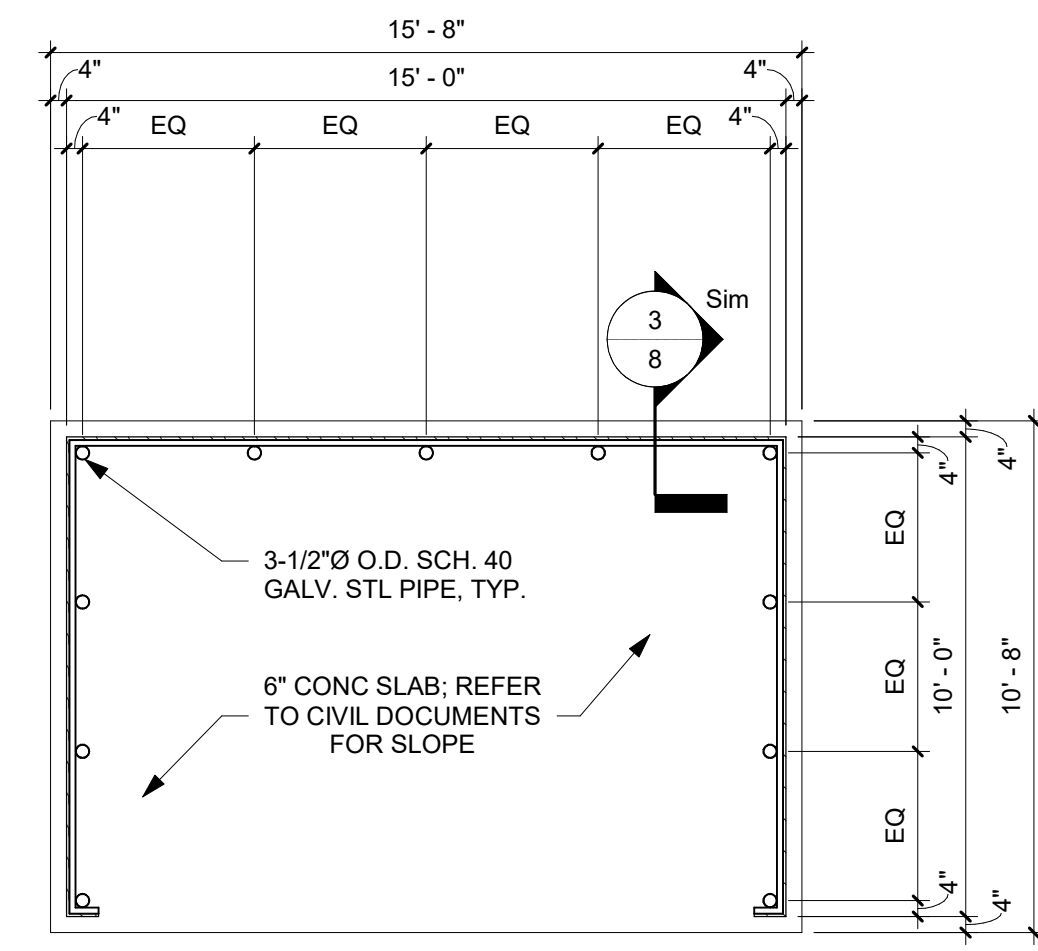

1 TRASH ENCLOSURE PLAN  
1/4" = 1'-0"

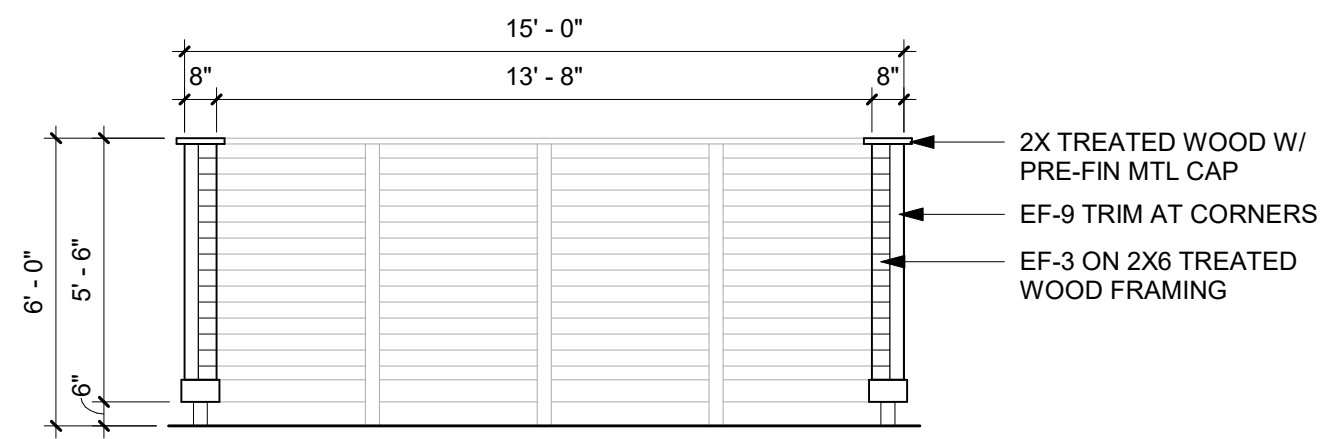

2 TRASH ENCLOSURE FRONT ELEVATION  
1/4" = 1'-0"

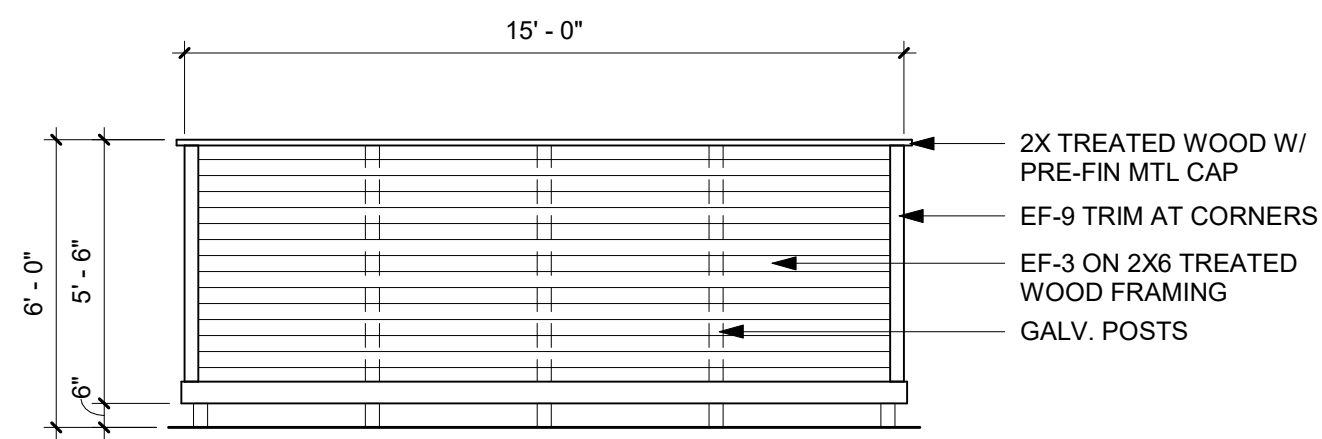

4 TRASH ENCLOSURE REAR ELEVATION  
1/4" = 1'-0"

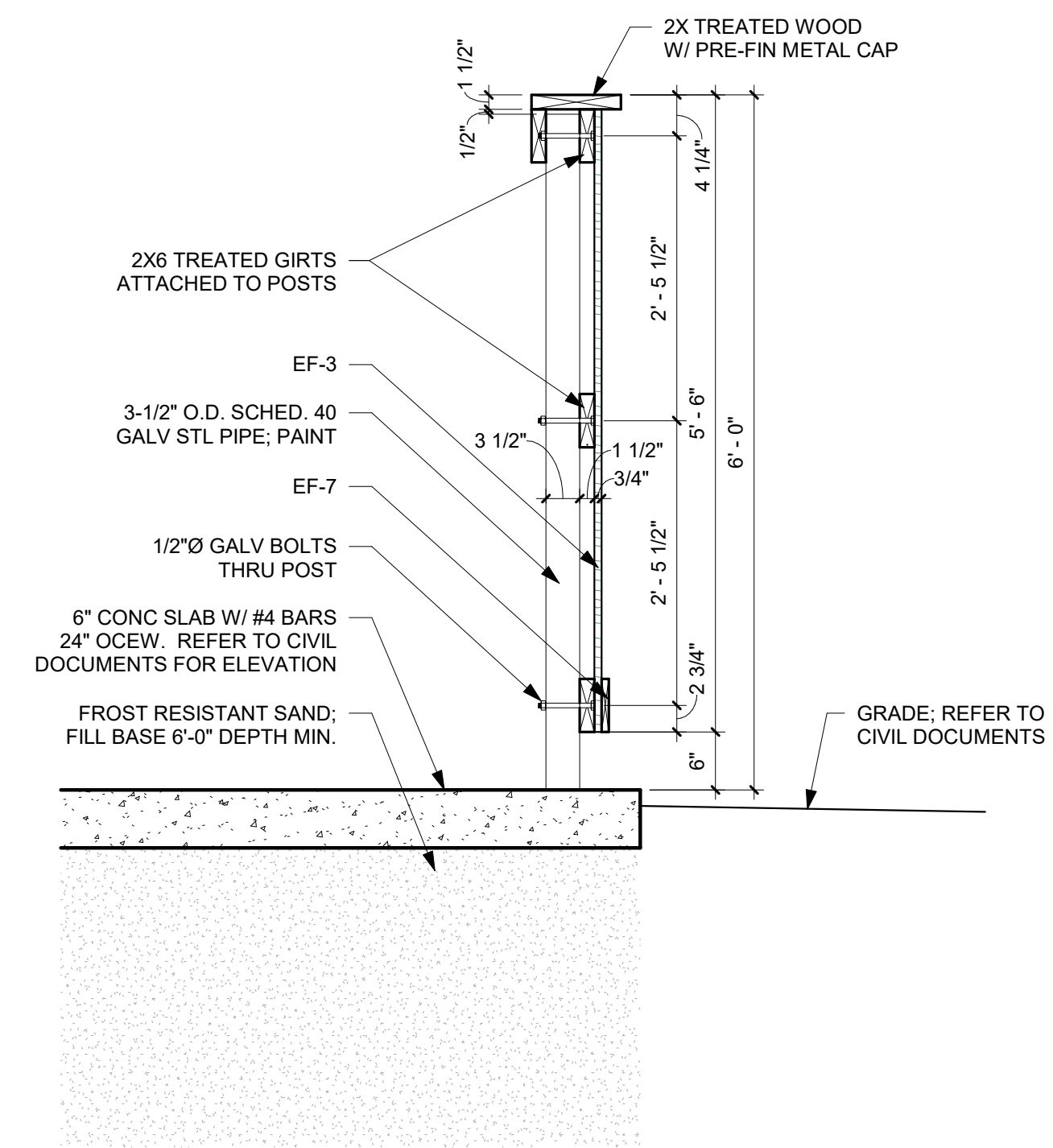

3 TRASH ENCLOSURE SECTION  
3/4" = 1'-0"

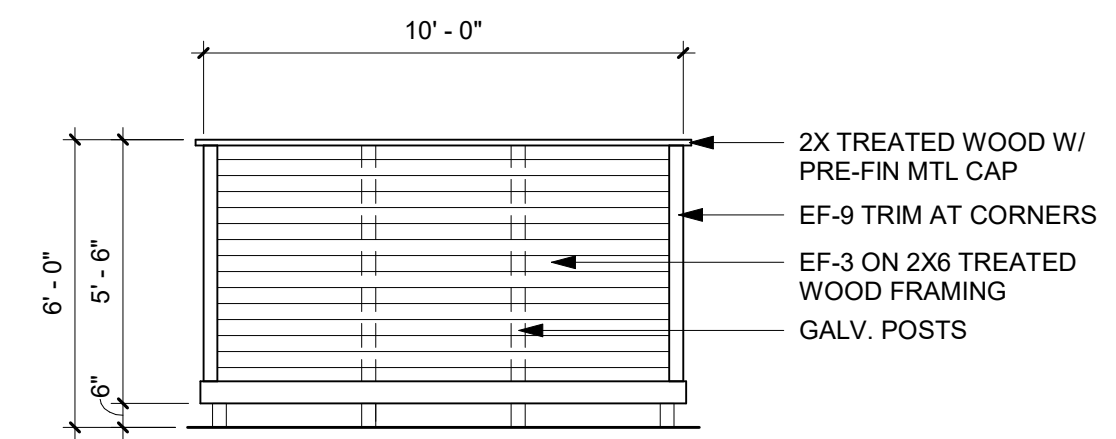

5 TRASH ENCLOSURE SIDE ELEVATION  
1/4" = 1'-0"

TRASH ENCLOSURE DETAILS

