



La Crosse Municipal Airport
Airport Manager's Office
2850 Airport Road
La Crosse, WI 54603

August 31, 2021

With copies to:
City Attorney
400 La Crosse Street
La Crosse, WI 54061

City Clerk
400 La Crosse Street
La Crosse, WI 54061

REQUEST FOR CONSENT TO SUBLEASE* AND APPROVAL OF PROPOSED INSTALLATION OF EQUIPMENT

SITE NUMBER	SITE NAME	PROJECT NUM.	CUSTOMER**
272487	LA CROSSE AIRPORT WI	13692976	DISH WIRELESS L.L.C.
SITE ADDRESS		GROUND AGREEMENT	
2810 Fanta Reed Rd LA CROSSE, Wisconsin 54603-1243		Lease Agreement dated December 19, 2007	

* the transaction contemplated may be a sublease, sub-sublease, license, or other form of conveyance whereby DISH WIRELESS L.L.C. is entering into an agreement to use this site.

** any reference to DISH WIRELESS L.L.C. includes one or more of its related entities.

Dear Landlord:

We, MD7, are assisting American Tower in the management of this site, including requesting consent from landlords on behalf of American Tower when such consent is required. We are writing to request your consent to a proposed sublease to DISH WIRELESS L.L.C. at this site. Since DISH WIRELESS L.L.C. will be a new customer at the site, we are required to get your written consent to this sublease per the ground agreement. We are also requesting your approval of the proposed equipment installation by DISH WIRELESS L.L.C., at this site. Included for your convenience are the Construction Drawings.

As wireless coverage demands continue to change, providers routinely expand their networks by placing equipment on new towers. Below are a few answers to frequently asked questions we receive from landlords on this type of project:

- All work will take place within the existing compound and on the existing tower.
- The overall appearance of the tower will remain similar.
- The addition of DISH WIRELESS L.L.C.'s equipment at a different height than existing carrier(s)' equipment will not change the overall height of the tower.
- The obligations and responsibilities of American Tower under the ground agreement are still in full force and effect.

If you could please consent to this sublease by signing this letter below and returning it to my attention, either by mail or email, I would appreciate it. American Tower values our relationship with you so if there are any questions please do not hesitate to contact me directly.

Thank you for your time.

Sincerely,



Amar Alhakim
Lease Consultant, MD7
E: aalhakim@md7.com | P: 858.754.2153

Consent

I consent to the proposed sublease* to DISH WIRELESS L.L.C. and approve of the proposed installation of equipment at the site referenced above.

Signature:  _____ Date: 11/04/221 _____

Print Name:

Title:



DISH Wireless L.L.C. SITE ID:

MNDLH00051A

DISH Wireless L.L.C. SITE ADDRESS:

**2810 FANTA REED RD
LA CROSSE, WI 54603**

THE PROJECT DEPICTED IN THESE PLANS QUALIFIES AS AN ELIGIBLE FACILITIES REQUEST ENTITLED TO EXPEDITED REVIEW UNDER 47 U.S.C. 1455(A) AS A MODIFICATION OF AN EXISTING WIRELESS TOWER THAT INVOLVES THE COLLOCATION REMOVAL AND/OR REPLACEMENT OF TRANSMISSION EQUIPMENT THAT IS NOT A SUBSTANTIAL CHANGE UNDER CFR 1.61000 (B)(7).

SCOPE OF WORK

THIS IS NOT AN ALL INCLUSIVE LIST. CONTRACTOR SHALL UTILIZE SPECIFIED EQUIPMENT PART OR ENGINEER APPROVED EQUIVALENT. CONTRACTOR SHALL VERIFY ALL NEEDED EQUIPMENT TO PROVIDE A FUNCTIONAL SITE. THE PROJECT GENERALLY CONSISTS OF THE FOLLOWING:

- TOWER SCOPE OF WORK:**
- INSTALL (3) PROPOSED PANEL ANTENNAS (1 PER SECTOR)
 - INSTALL (1) PROPOSED TOWER PLATFORM MOUNT
 - INSTALL PROPOSED JUMPERS
 - INSTALL (6) PROPOSED RRUs (2 PER SECTOR)
 - INSTALL (1) PROPOSED OVER VOLTAGE PROTECTION DEVICE (OVP)
 - INSTALL (1) PROPOSED HYBRID CABLE

- GROUND SCOPE OF WORK:**
- INSTALL (1) PROPOSED METAL PLATFORM
 - INSTALL (1) PROPOSED ICE BRIDGE
 - INSTALL (1) PROPOSED PPC CABINET
 - INSTALL (1) PROPOSED EQUIPMENT CABINET
 - INSTALL (1) PROPOSED POWER CONDUIT
 - INSTALL (1) PROPOSED TELCO CONDUIT
 - INSTALL (1) PROPOSED TELCO-FIBER BOX
 - INSTALL (1) PROPOSED GPS UNIT
 - INSTALL (1) PROPOSED FIBER NID (IF REQUIRED)

SITE INFORMATION

PROPERTY OWNER: CITY OF LACROSSE
 ADDRESS: 400 LA CROSSE ST
 LA CROSSE, WI 54601

TOWER TYPE: MONOPOLE

TOWER CO SITE ID: 272487

TOWER APP NUMBER: 13692976

COUNTY: LA CROSSE

LATITUDE (NAD 83): 43° 52' 18.3" N
 43.871750 N

LONGITUDE (NAD 83): 91° 15' 11.1" W
 91.253083 W

ZONING JURISDICTION: CITY OF LA CROSSE

ZONING DISTRICT: UNZONED

PARCEL NUMBER: 17-10253-20

OCCUPANCY GROUP: U

CONSTRUCTION TYPE: II-B

POWER COMPANY: XCEL

TELEPHONE COMPANY: CENTURY TEL

PROJECT DIRECTORY

APPLICANT: DISH Wireless L.L.C.
 5701 SOUTH SANTA FE DRIVE
 LITTLETON, CO 80120

TOWER OWNER: AMERICAN TOWER CORPORATION
 10 PRESIDENTIAL WAY
 WOBURN, MA 01801
 (781) 926-4500

SITE DESIGNER: B+T GROUP
 1717 S. BOULDER AVE, SUITE 300
 TULSA, OK 74119
 (918) 587-4630

SITE ACQUISITION: NOURA ELMANSY
 noura.elmansy@dish.com

CONSTRUCTION MANAGER: MOHAMMED MOHAMMED
 mohammed.mohammed@dish.com

RF ENGINEER: CHRISTOPHER HUMES
 christopher.humes@dish.com



5701 SOUTH SANTA FE DRIVE
 LITTLETON, CO 80120



B&T ENGINEERING, INC.

IT IS A VIOLATION OF LAW FOR ANY PERSON, UNLESS THEY ARE ACTING UNDER THE DIRECTION OF A LICENSED PROFESSIONAL ENGINEER, TO ALTER THIS DOCUMENT.

DRAWN BY: ANP CHECKED BY: JCO APPROVED BY: MDW

RFDS REV #: 1.0

PRELIMINARY DOCUMENTS

SUBMITTALS		
REV	DATE	DESCRIPTION
A	8/13/21	ISSUED FOR REVIEW
0	8/27/21	ISSUED FOR CONSTRUCTION

A&E PROJECT NUMBER
 153984.001.01

DISH Wireless L.L.C.
 PROJECT INFORMATION
 MNDLH00051A
 2810 FANTA REED RD
 LA CROSSE, WI 54603

SHEET TITLE
 TITLE SHEET

SHEET NUMBER
T-1

WISCONSIN CODE COMPLIANCE

ALL WORK SHALL BE PERFORMED AND MATERIALS INSTALLED IN ACCORDANCE WITH THE CURRENT EDITIONS OF THE FOLLOWING CODES AS ADOPTED BY THE LOCAL GOVERNING AUTHORITIES. NOTHING IN THESE PLANS IS TO BE CONSTRUED TO PERMIT WORK NOT CONFORMING TO THESE CODES:

CODE TYPE	CODE
BUILDING	WISCONSIN CBC/2015 IBC W/ WI AMENDMENTS
MECHANICAL	WISCONSIN CBC/2015 IMC W/ WI AMENDMENTS
ELECTRICAL	WISCONSIN ELECTRICAL CODE/2017 NEC W/ WI AMENDMENTS

SITE PHOTO



DIRECTIONS

DIRECTIONS FROM LA CROSSE REGIONAL AIRPORT:
 HEAD NORTH CONTINUE ONTO AIRPORT DR TURN LEFT ONTO FANTA REED RD TURN LEFT TO STAY ON FANTA REED RD. ARRIVE AT MNDLH00051A.

VICINITY MAP

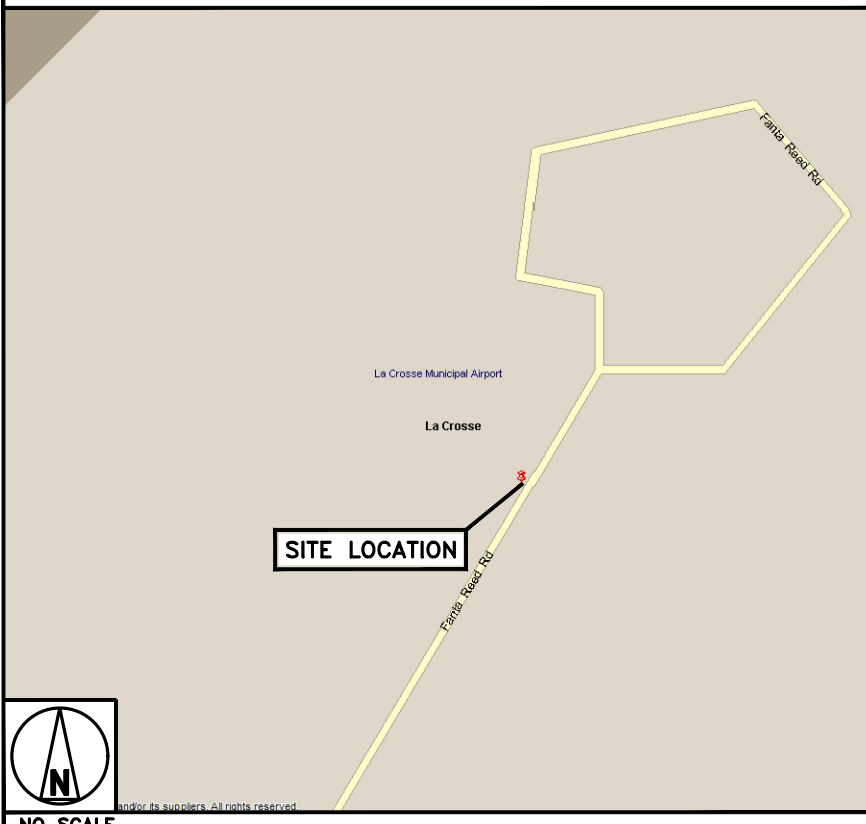

UNDERGROUND SERVICE ALERT - DIGGERS HOTLINE
 UTILITY NOTIFICATION CENTER OF WISCONSIN
 (800) 242-8511
 WWW.DIGGERSHOTLINE.COM

CALL 3 WORKING DAYS UTILITY NOTIFICATION PRIOR TO CONSTRUCTION

GENERAL NOTES

THE FACILITY IS UNMANNED AND NOT FOR HUMAN HABITATION. A TECHNICIAN WILL VISIT THE SITE AS REQUIRED FOR ROUTINE MAINTENANCE. THE PROJECT WILL NOT RESULT IN ANY SIGNIFICANT DISTURBANCE OR EFFECT ON DRAINAGE, NO SANITARY SEWER SERVICE, POTABLE WATER, OR TRASH DISPOSAL IS REQUIRED AND NO COMMERCIAL SIGNAGE IS PROPOSED.

11"x17" PLOT WILL BE HALF SCALE UNLESS OTHERWISE NOTED

CONTRACTOR SHALL VERIFY ALL PLANS, EXISTING DIMENSIONS, AND CONDITIONS ON THE JOB SITE, AND SHALL IMMEDIATELY NOTIFY THE ENGINEER IN WRITING OF ANY DISCREPANCIES BEFORE PROCEEDING WITH THE WORK.

dish wireless.

5701 SOUTH SANTA FE DRIVE
LITTLETON, CO 80120

AMERICAN TOWER
10 PRESIDENTIAL WAY
WOBRUN, MA 01801

B+T GRP
1717 S. BOULDER
SUITE 300
TULSA, OK 74119
PH: (918) 587-4630
www.btgrp.com



B&T ENGINEERING, INC.

IT IS A VIOLATION OF LAW FOR ANY PERSON, UNLESS THEY ARE ACTING UNDER THE DIRECTION OF A LICENSED PROFESSIONAL ENGINEER, TO ALTER THIS DOCUMENT.

DRAWN BY: ANP
CHECKED BY: JCO
APPROVED BY: MDW

RFDS REV #: 1.0

PRELIMINARY DOCUMENTS

SUBMITTALS		
REV	DATE	DESCRIPTION
A	8/13/21	ISSUED FOR REVIEW
0	8/27/21	ISSUED FOR CONSTRUCTION

A&E PROJECT NUMBER
153984.001.01

DISH Wireless L.L.C.
PROJECT INFORMATION
MNDLH00051A
2810 FANTA REED RD
LA CROSSE, WI 54603

SHEET TITLE
**SITE SURVEY
SITE PLAN**

SHEET NUMBER
LS-1

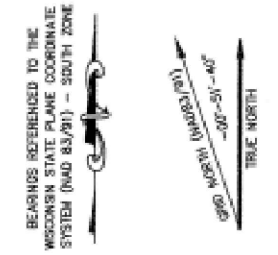
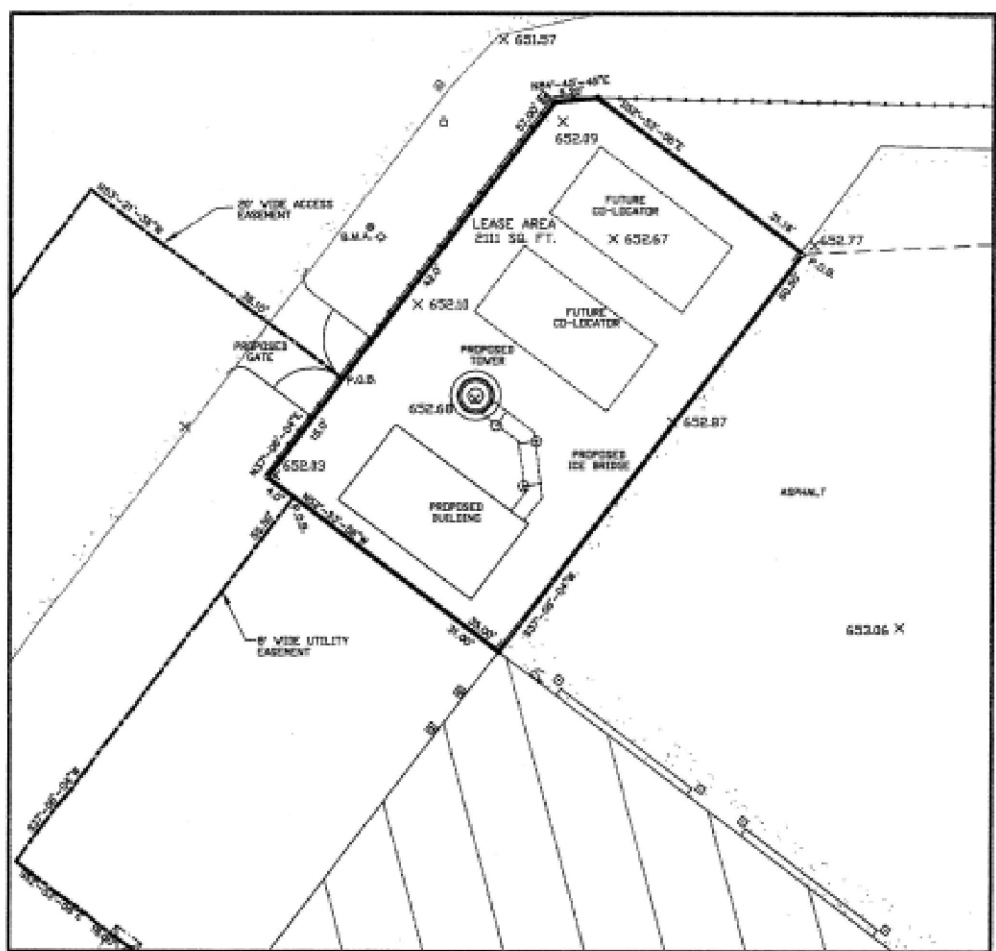
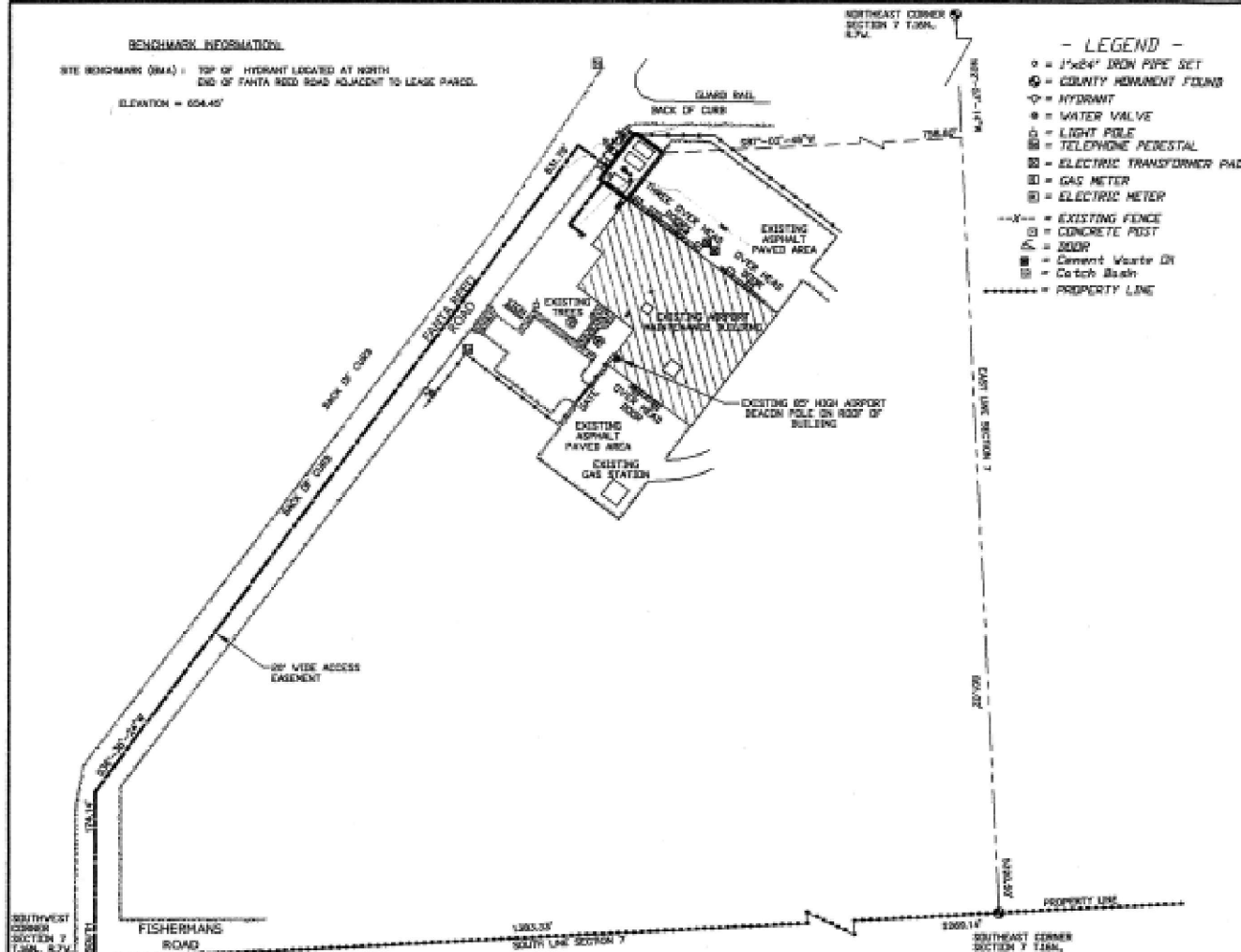

PROJECT: AIRPORT BEACON # W 5711
SURVEYED FOR: APEX ENGINEERS, INC.
PROPERTY OWNER: CITY OF LACROSSE
SITE ADDRESS: 2810 FANTA REED ROAD
TAX KEY NUMBER: N/A
ZONED: PUBLIC/SEM-PUBLIC
DEED: VOL. PG. N/A

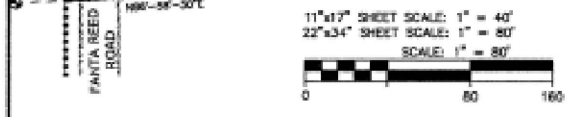

LEASE PARCEL
A part of the Southeast Quarter (SE1/4) of the Southeast Quarter (SE1/4) of Section Seven (7), Township Sixteen (16) North, Range Seven (7) West, City of LaCrosse, LaCrosse County, Wisconsin containing 2.01 square feet (0.046 acres) of land and being described by:
Commencing at the Southeast Corner of said Section 7; thence N82°57'14"W along the East line of said Section 7, 891.82 feet; thence S87°02'46"W 758.80 feet to the point of beginning; thence S37°06'04"W 625.8 feet; thence N92°53'36"W 351.0 feet; thence N87°06'04"E 37.6 feet; thence N84°43'45"E 3.28 feet; thence S32°53'36"E 351.6 feet to the point of beginning; being subject to any and all easements and restrictions of record.

CENTERLINE 8 FOOT WIDE UTILITY EASEMENT
An 8 foot wide Utility Easement being a part of the Southeast Quarter (SE1/4) of the Southeast Quarter (SE1/4) of Section Seven (7), Township Sixteen (16) North, Range Seven (7) West, City of LaCrosse, LaCrosse County, Wisconsin containing 588 square feet (0.013 acres) of land and being 4 feet each side of and parallel to a line described by:
Commencing at the Southeast Corner of said Section 7; thence N82°57'14"W along the East line of said Section 7, 891.82 feet; thence S87°02'46"W 758.80 feet; thence S37°06'04"E 625.8 feet; thence N92°53'36"W 351.0 feet to the point of termination.

PROPOSED TOWER BASE
Latitude: 43°52'18.31"
Longitude: 91°15'11.3"
(Per North American Datum of 1983/81)
Elevation: 653.0'
(Per National Geodetic Vertical Datum of 1929)

CENTERLINE 20 FOOT WIDE ACCESS EASEMENT
A 20 foot wide Access Easement being a part of the Southeast Quarter (SE1/4) of Section Seven (7), Township Sixteen (16) North, Range Seven (7) West, City of LaCrosse, LaCrosse County, Wisconsin containing 29,090 square feet (0.679 acres) of land and being 10 feet each side of and parallel to a line described by:
Commencing at the Southeast Corner of said Section 7; thence N62°57'14"W along the East line of said Section 7, 891.82 feet; thence S87°02'46"W 758.80 feet; thence S37°06'04"E 625.8 feet; thence N92°53'36"W 351.0 feet; thence N87°06'04"E 37.6 feet; thence N84°43'45"E 3.28 feet; thence S32°53'36"E 351.6 feet; thence South 1743.6 feet to the South line of Section 7 and the North line of Fanta Reed Road being the point of termination.

I, Anthony P. Lulloff, hereby certify that none of the property described hereon is within a flood plain or wetlands area as defined by FEMA or Wisconsin DNR.
SURVEYOR'S CERTIFICATE

I, Anthony P. Lulloff, Wisconsin Registered Land Surveyor of Aero-Metric, Inc., certify that I have surveyed the described property and that the map shown is a true and accurate representation thereof to the best of my knowledge and belief.

Dated this 10th day of January, 2008.
Anthony P. Lulloff
WISCONSIN REGISTERED LAND SURVEYOR
Anthony P. Lulloff 8-1855

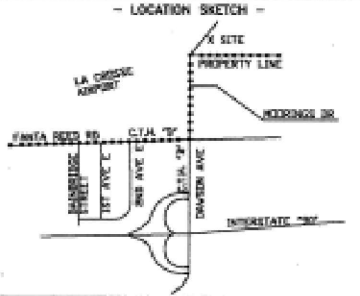
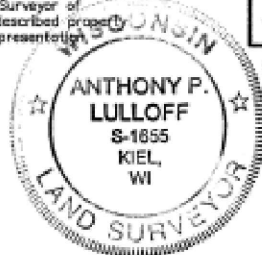

SITE SURVEY FOR CINGULAR WIRELESS
A PART OF THE SE1/4, SECTION 7, T.16N., R.7W., CITY OF LACROSSE, LA CROSSE COUNTY, WISCONSIN
DWG. FILE: AP-BEACONDATE: 8/16/08
DRAWN BY: K.S. CHECKED BY: B.A.B.
PROJECT NO.: 2080119
NOTEBOOK: P-311 PAGE: 64-65

Apex Engineers, Inc.
Structural & Civil Engineers
500 EAST 22ND STREET
LOMBARD, ILLINOIS 60148
Ph. (630) 627-1800
Fax. (630) 627-1165
APEX JOB No. C104-119

AIRPORT BEACON SITE NO. WI5711
2810 FANTA REED ROAD
LACROSSE, WI 54603



NO.	DATE	REVISIONS	BY	CHK APP'D
1	8/22/08	PRELIMINARY		
2	9/3/08	FINAL		
3	9/13/08	ADD EASEMENT		
4	1/16/09	DETAIL PROPERTY LINES		

SHEET NO.
1 OF 1
FILE NO.
K-1330

SURVEYED BY:
AERO-METRIC
Aero-Metric, Incorporated
Land Planning & Design Division
420-444-7700 FAX: 420-444-7702
547 NORTH WISCONSIN STREET, SUITE 200, WISCONSIN 53604
DRAWING NUMBER
WI5711

NOTES

1. CONTRACTOR SHALL FIELD VERIFY ALL DIMENSIONS.
2. ANTENNAS AND MOUNTS OMITTED FOR CLARITY.

NOTES

1. CONTRACTOR SHALL FIELD VERIFY ALL DIMENSIONS.
2. CONTRACTOR SHALL MAINTAIN A 10'-0" MINIMUM SEPARATION BETWEEN THE PROPOSED GPS UNIT, TRANSMITTING ANTENNAS AND EXISTING GPS UNITS.
3. ANTENNAS AND MOUNTS OMITTED FOR CLARITY.



5701 SOUTH SANTA FE DRIVE
LITTLETON, CO 80120



B&T ENGINEERING, INC.

IT IS A VIOLATION OF LAW FOR ANY PERSON, UNLESS THEY ARE ACTING UNDER THE DIRECTION OF A LICENSED PROFESSIONAL ENGINEER, TO ALTER THIS DOCUMENT.

DRAWN BY: ANP
CHECKED BY: JCO
APPROVED BY: MDW

RFDS REV #: 1.0

PRELIMINARY DOCUMENTS

SUBMITTALS		
REV	DATE	DESCRIPTION
A	8/13/21	ISSUED FOR REVIEW
0	8/27/21	ISSUED FOR CONSTRUCTION

A&E PROJECT NUMBER
153984.001.01

DISH Wireless L.L.C.
PROJECT INFORMATION
MNDLH00051A
2810 FANTA REED RD
LA CROSSE, WI 54603

SHEET TITLE
OVERALL AND ENLARGED
SITE PLAN

SHEET NUMBER
A-1

FANTA REED ROAD

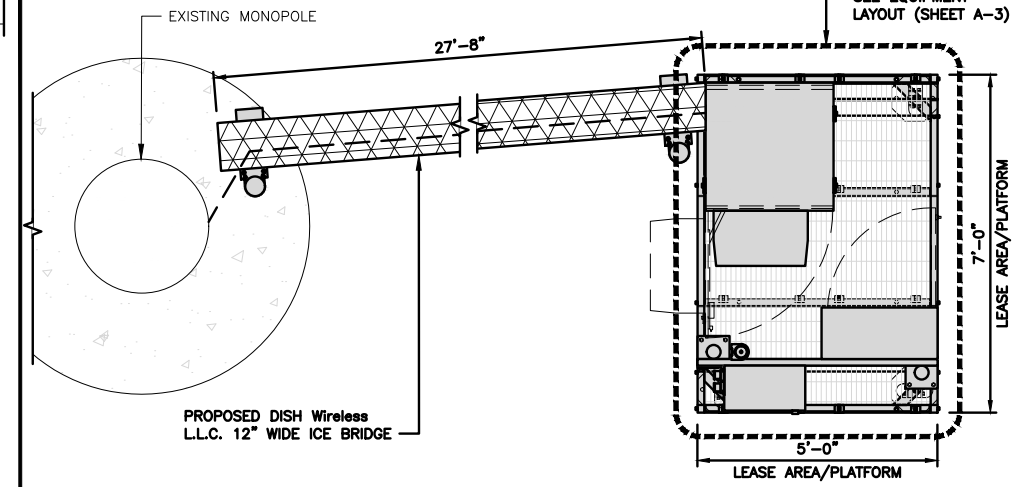
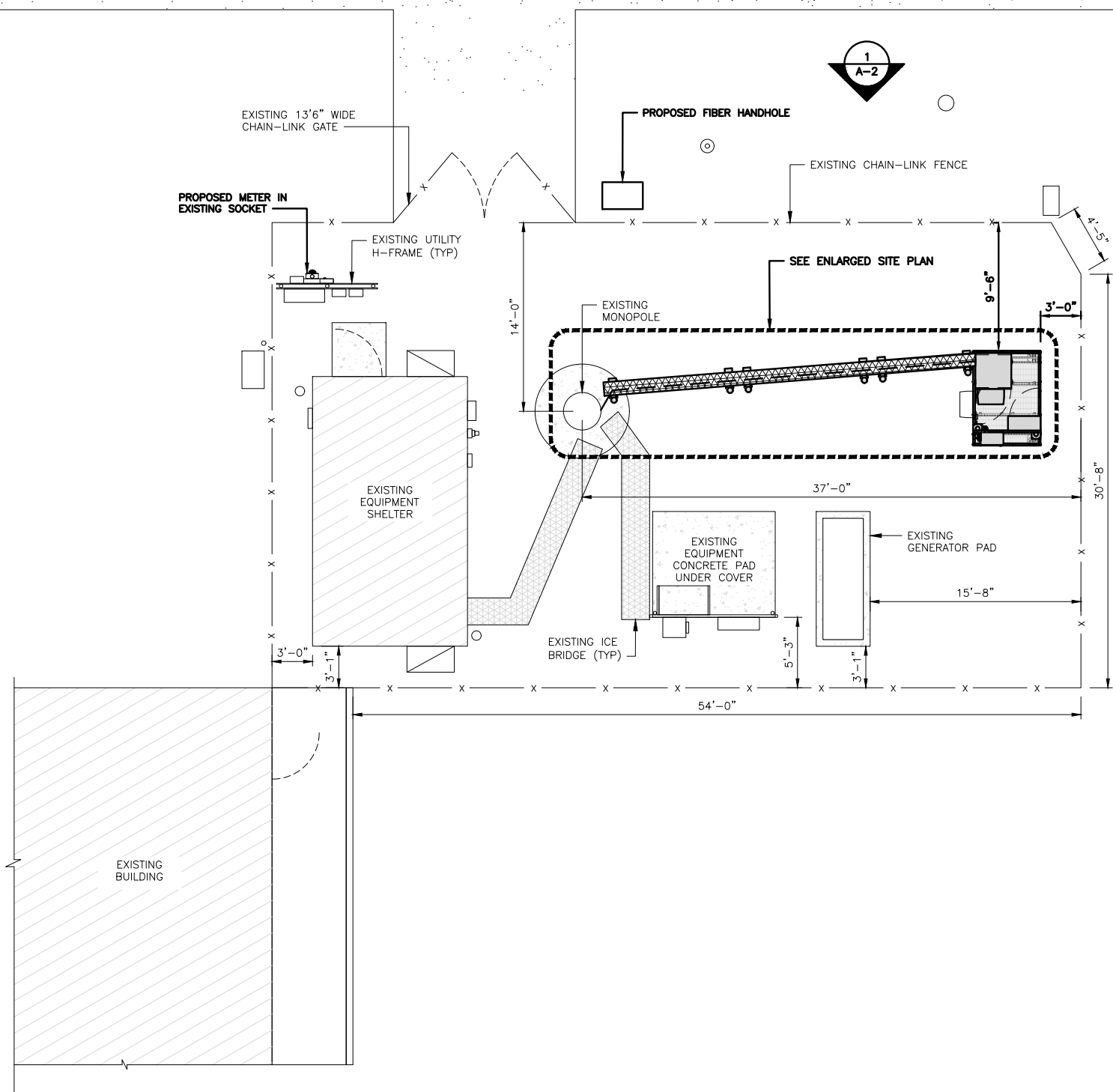

ENLARGED SITE PLAN

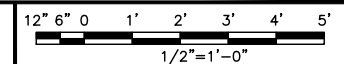

2

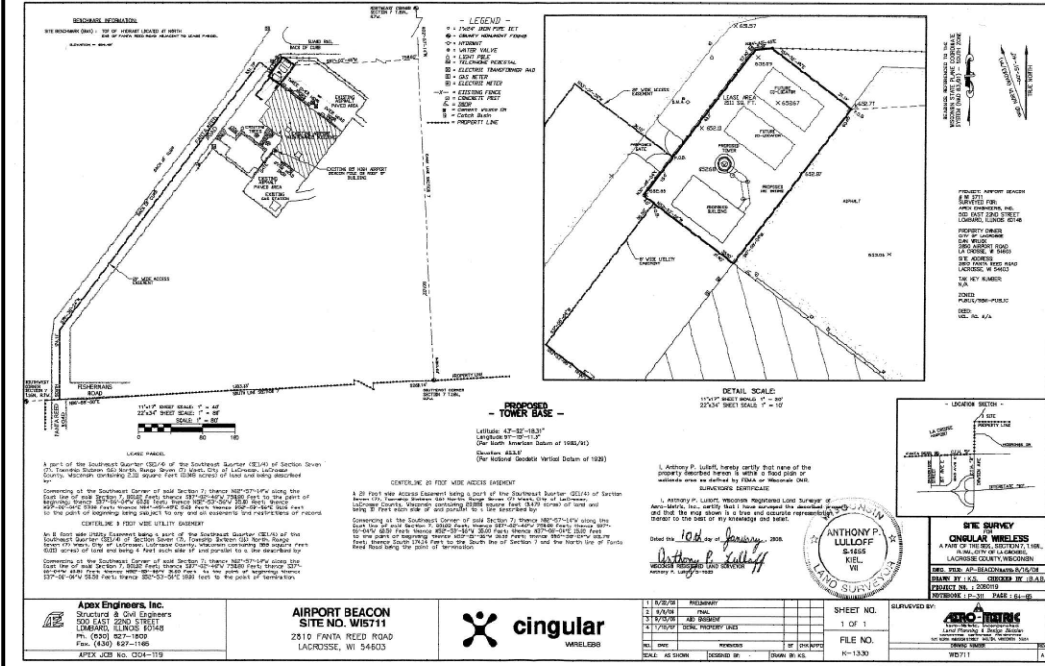

THE SURVEY PROVIDED ON THIS SHEET IS PROVIDED FOR REFERENCE ONLY, THE UTILITY ROUTE AND EXISTING EASEMENTS MUST BE VERIFIED PRIOR TO CONSTRUCTION.

SURVEY SHEET

NO SCALE

3

OVERALL SITE PLAN

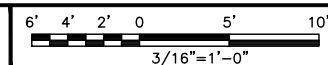

1

NOTES

1. CONTRACTOR SHALL FIELD VERIFY ALL DIMENSIONS.
2. ANTENNA AND MW DISH SPECIFICATIONS REFER TO ANTENNA SCHEDULE AND TO FINAL CONSTRUCTION RFDS FOR ALL RF DETAILS
3. EXISTING EQUIPMENT AND FENCE OMITTED FOR CLARITY.

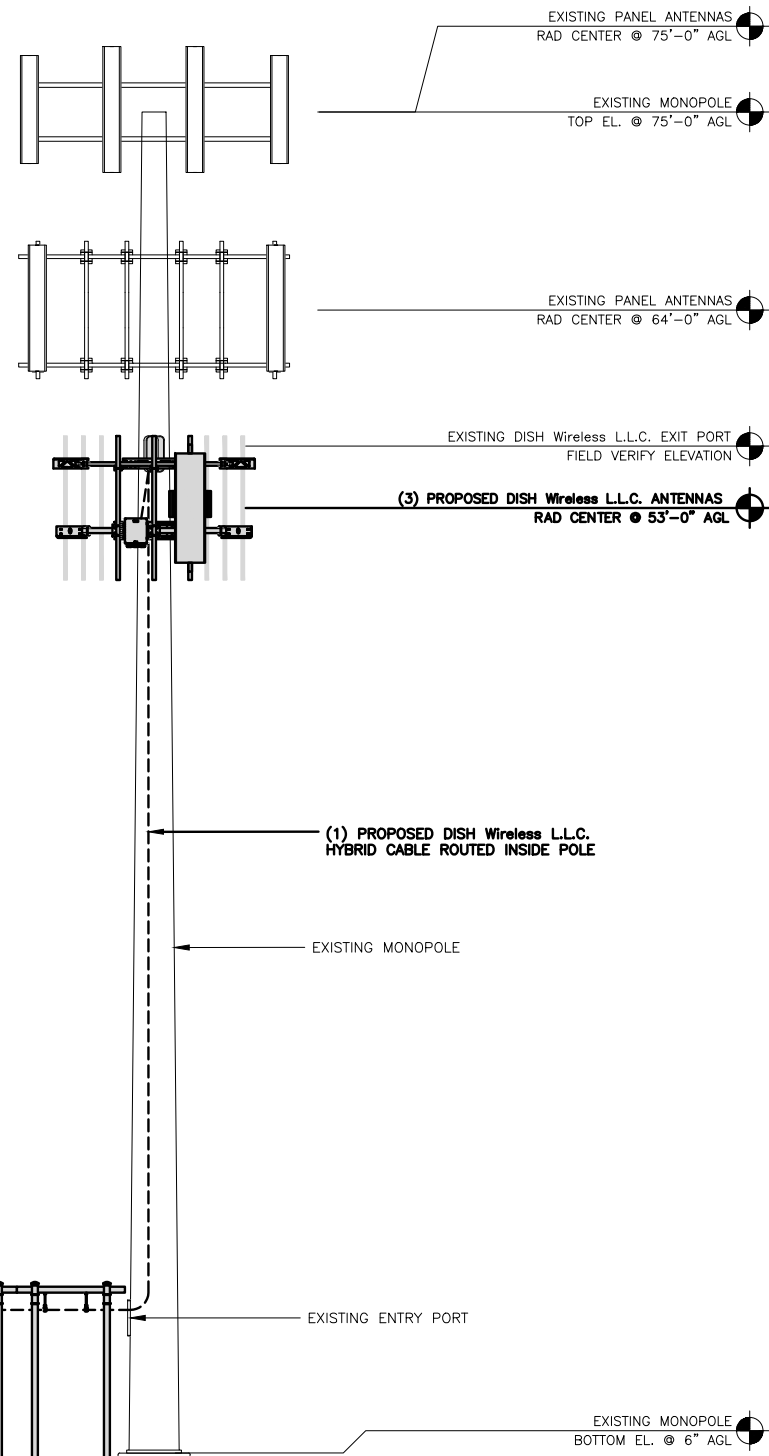

PROPOSED NORTHWEST ELEVATION

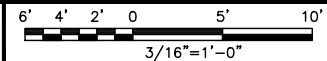

1

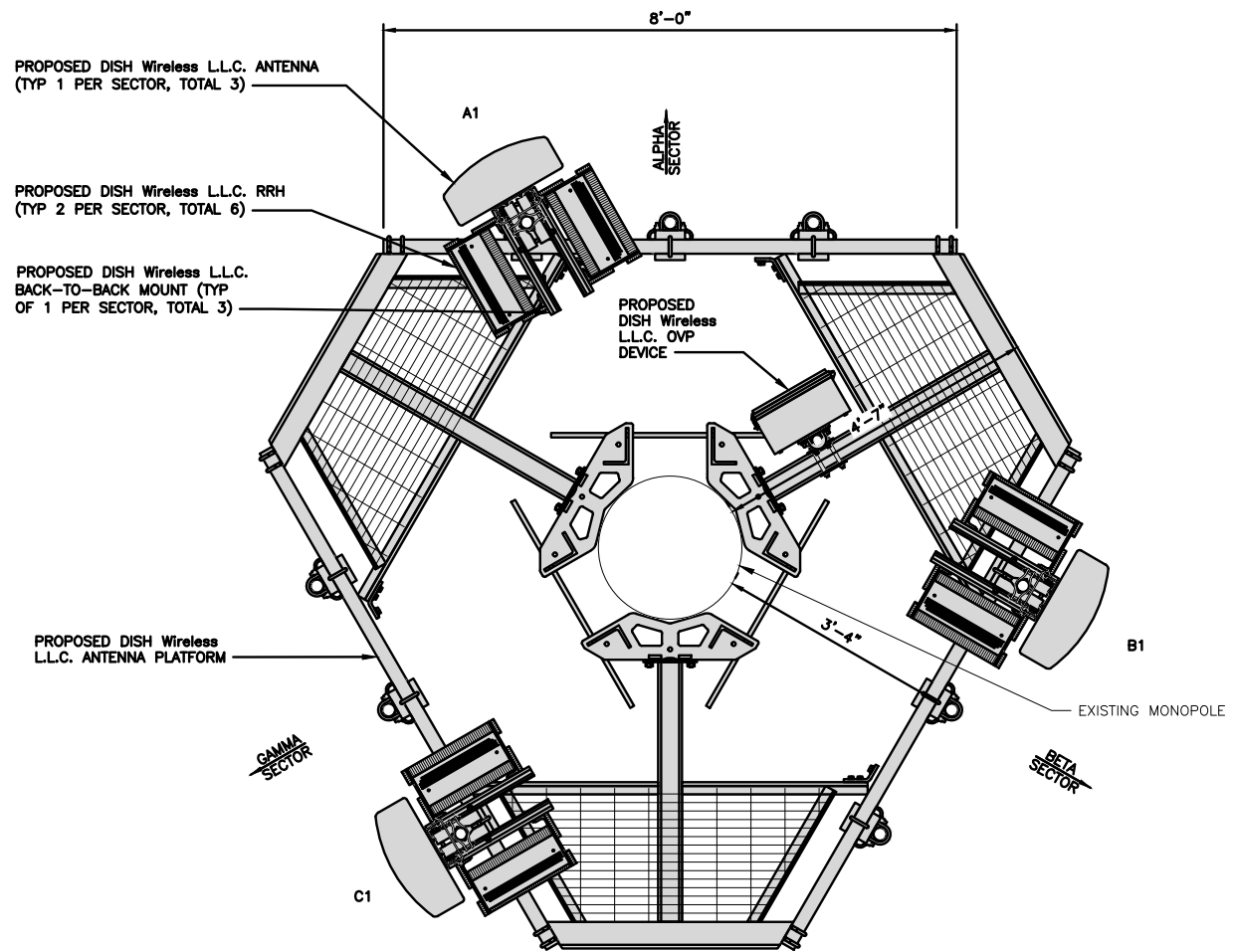

ANTENNA LAYOUT

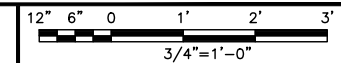

2

SECTOR	POSITION	ANTENNA					TRANSMISSION CABLE	
		EXISTING OR PROPOSED	MANUFACTURER - MODEL NUMBER	TECHNOLOGY	SIZE (HxW)	AZIMUTH	RAD CENTER	FEED LINE TYPE AND LENGTH
ALPHA	A1	PROPOSED	JMA WIRELESS-MX08FR0665-21	5G	72.0" x 20.0"	330°	53'-0"	(1) HIGH-CAPACITY HYBRID CABLE (105' LONG)
BETA	B1	PROPOSED	JMA WIRELESS-MX08FR0665-21	5G	72.0" x 20.0"	120°	53'-0"	
GAMMA	C1	PROPOSED	JMA WIRELESS-MX08FR0665-21	5G	72.0" x 20.0"	240°	53'-0"	

SECTOR	POSITION	RRH		NOTES
		MANUFACTURER - MODEL NUMBER	TECHNOLOGY	
ALPHA	A1	FUJITSU-TA08025-B605	5G	1. CONTRACTOR TO REFER TO FINAL CONSTRUCTION RFDS FOR ALL RF DETAILS. 2. ANTENNA AND RRH MODELS MAY CHANGE DUE TO EQUIPMENT AVAILABILITY. ALL EQUIPMENT CHANGES MUST BE APPROVED AND REMAIN IN COMPLIANCE WITH THE PROPOSED DESIGN AND STRUCTURAL ANALYSES.
	A1	FUJITSU-TA08025-B604	5G	
BETA	B1	FUJITSU-TA08025-B605	5G	
	B1	FUJITSU-TA08025-B604	5G	
GAMMA	C1	FUJITSU-TA08025-B605	5G	
	C1	FUJITSU-TA08025-B604	5G	

ANTENNA SCHEDULE

NO SCALE

3



5701 SOUTH SANTA FE DRIVE
LITTLETON, CO 80120



B&T ENGINEERING, INC.

IT IS A VIOLATION OF LAW FOR ANY PERSON, UNLESS THEY ARE ACTING UNDER THE DIRECTION OF A LICENSED PROFESSIONAL ENGINEER, TO ALTER THIS DOCUMENT.

DRAWN BY:	CHECKED BY:	APPROVED BY:
ANP	JCO	MDW

RFDS REV #: 1.0

PRELIMINARY DOCUMENTS

SUBMITTALS		
REV	DATE	DESCRIPTION
A	8/13/21	ISSUED FOR REVIEW
0	8/27/21	ISSUED FOR CONSTRUCTION

A&E PROJECT NUMBER
153984.001.01

DISH Wireless L.L.C. PROJECT INFORMATION
MNDLH00051A
2810 FANTA REED RD
LA CROSSE, WI 54603

SHEET TITLE
ELEVATION, ANTENNA LAYOUT AND SCHEDULE

SHEET NUMBER
A-2



5701 SOUTH SANTA FE DRIVE
LITTLETON, CO 80120



B&T ENGINEERING, INC.

IT IS A VIOLATION OF LAW FOR ANY PERSON, UNLESS THEY ARE ACTING UNDER THE DIRECTION OF A LICENSED PROFESSIONAL ENGINEER, TO ALTER THIS DOCUMENT.

DRAWN BY: ANP CHECKED BY: JCO APPROVED BY: MDW

RFDS REV #: 1.0

PRELIMINARY DOCUMENTS

SUBMITTALS		
REV	DATE	DESCRIPTION
A	8/13/21	ISSUED FOR REVIEW
0	8/27/21	ISSUED FOR CONSTRUCTION

A&E PROJECT NUMBER
153984.001.01

DISH Wireless L.L.C.
PROJECT INFORMATION

MNDLH00051A
2810 FANTA REED RD
LA CROSSE, WI 54603

SHEET TITLE
EQUIPMENT PLATFORM AND H-FRAME DETAILS

SHEET NUMBER
A-3

NOTES

1. CONTRACTOR TO BURY PLATFORM FEET WITH A MINIMUM OF 2" OF FILL PER EXISTING SITE SURFACE
2. WEED BARRIER FABRIC TO BE ADDED AT DISCRETION OF DISH Wireless L.L.C. CONSTRUCTION MANAGER AT TIME OF CONSTRUCTION. ONE SHEET 8'x8' INSTALLED UNDER ALL FOUR FEET OF THE PLATFORM (4 MIL BLACK PLASTIC)
3. EQUIPMENT CABINET OMITTED FOR CLARITY

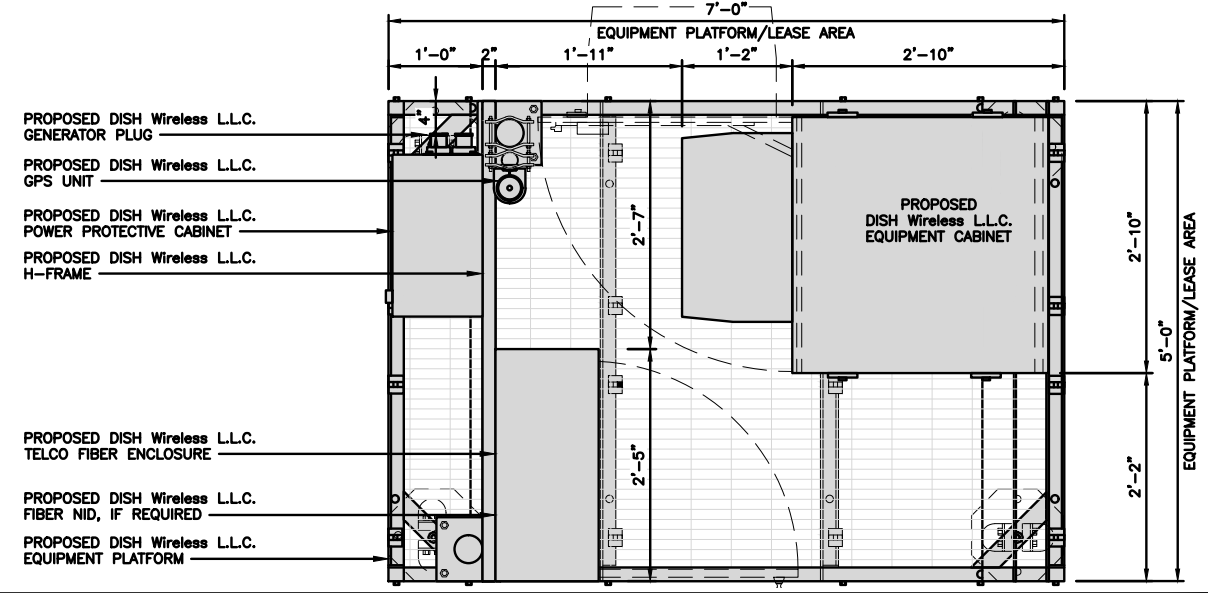

PLATFORM EQUIPMENT PLAN

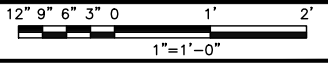

1

COMMSCOPE MTC4045LP 5X7 PLATFORM	
DIMENSIONS (HxWxD)	16"x84"x60"
TOTAL WEIGHT	423 LBS

NOTE:
GC TO PROVIDE EXTENDED THREAD FOR PLATFORM IF REQUIRED HEIGHT EXCEEDS 17"

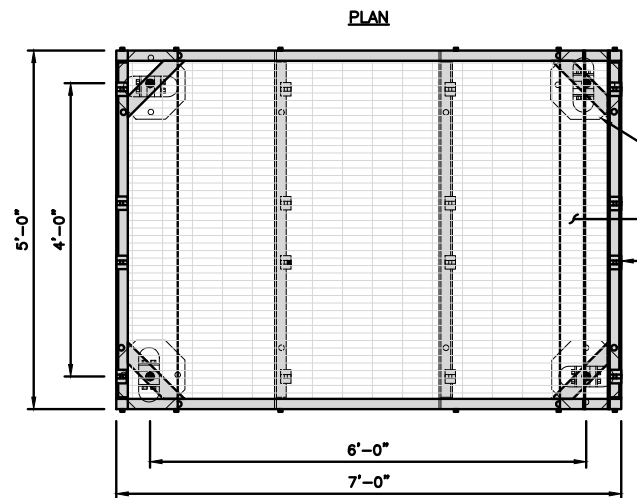

PLATFORM DETAIL

NO SCALE 2

COMMSCOPE MTC4045HFLD H-FRAME	
UNISTRUT/SUPPORT RAILS QTY	5
WEIGHT	59.74 lbs

NOTE:
OR DISH Wireless L.L.C. APPROVED EQUIVALENT

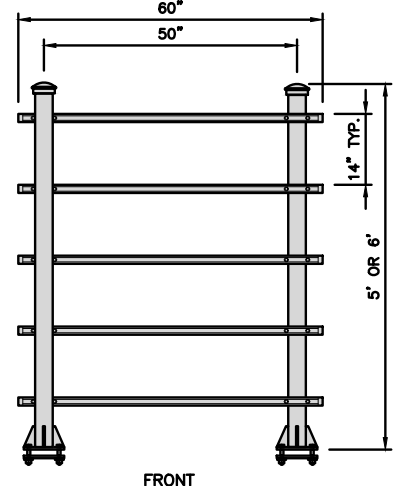
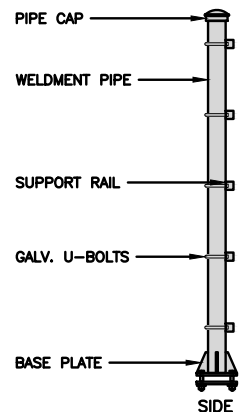

H-FRAME DETAIL

NO SCALE 3

NOT USED

NO SCALE 4

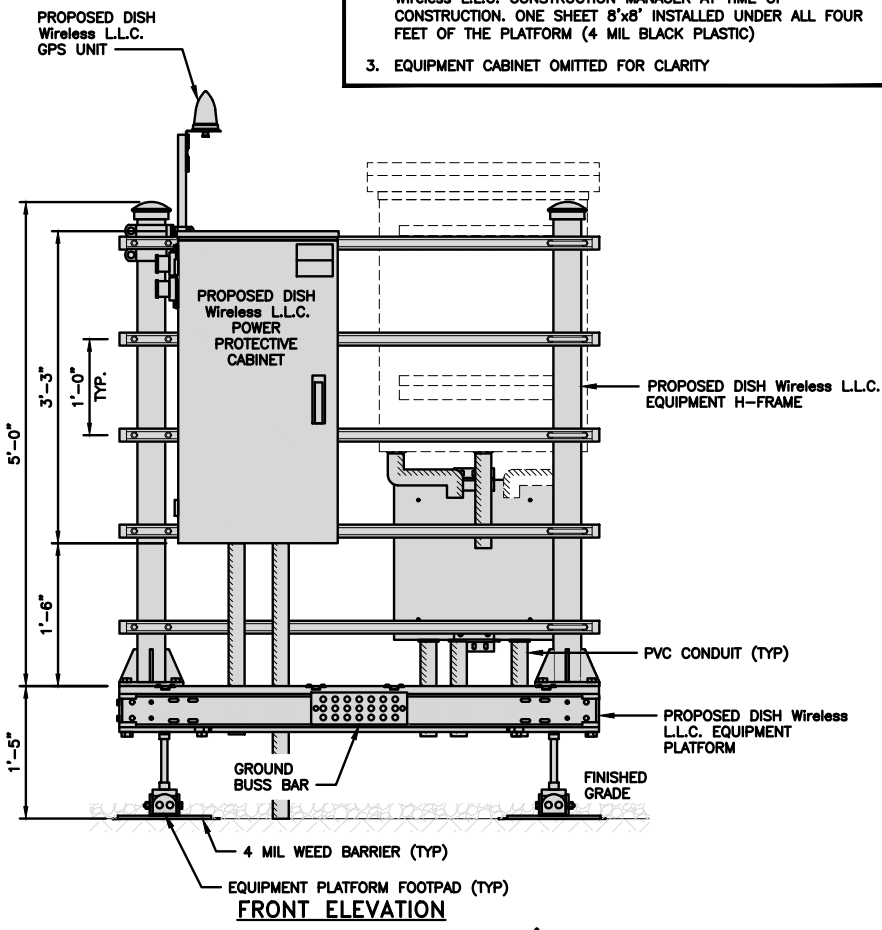

FRONT ELEVATION

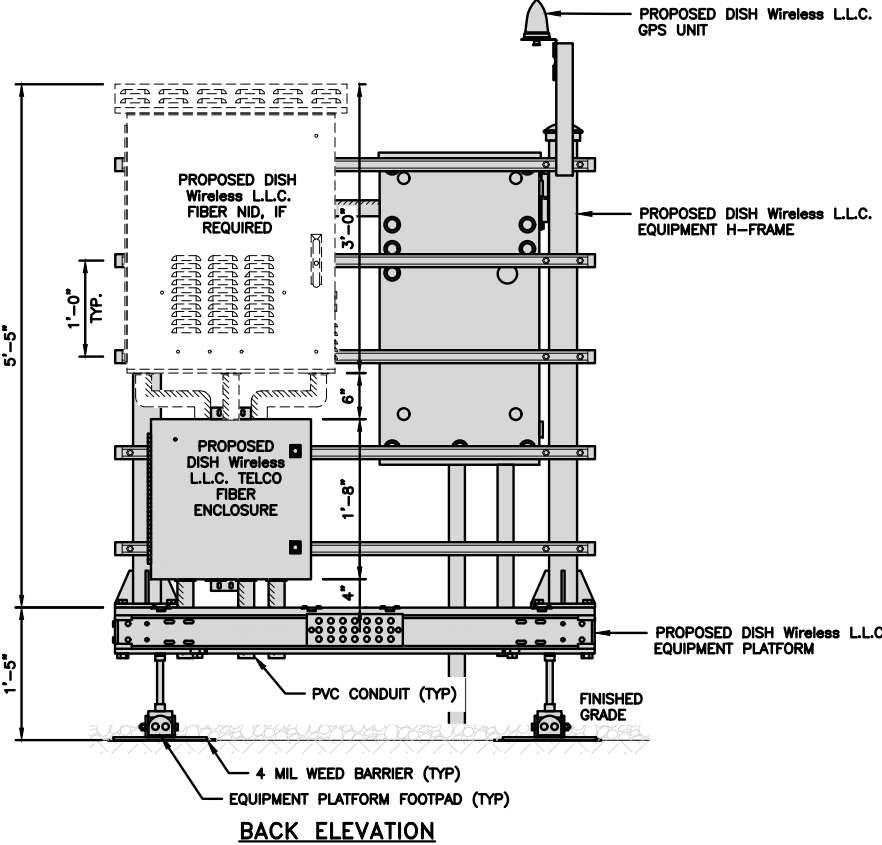

BACK ELEVATION

H-FRAME EQUIPMENT ELEVATION

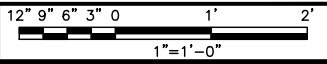

5

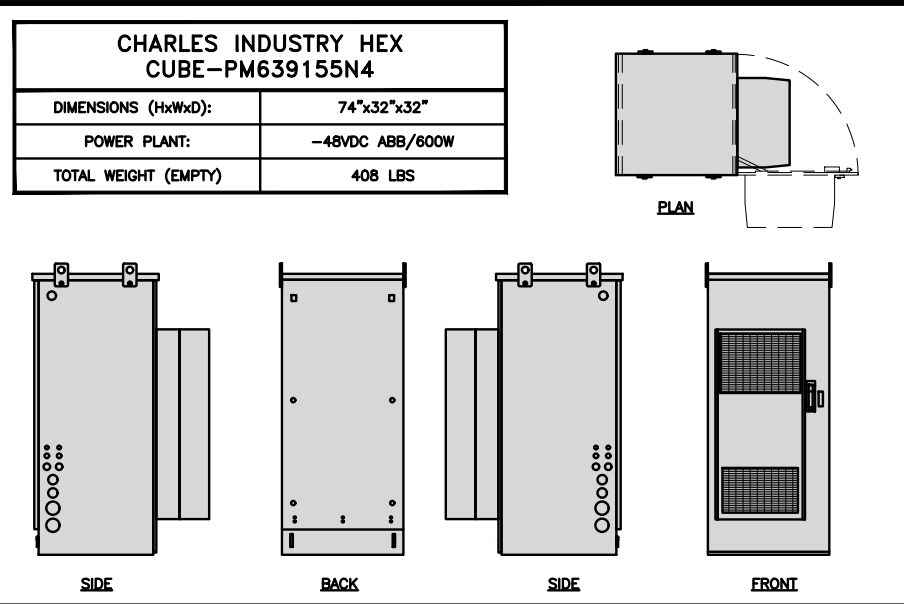

CABINET DETAIL NO SCALE 1

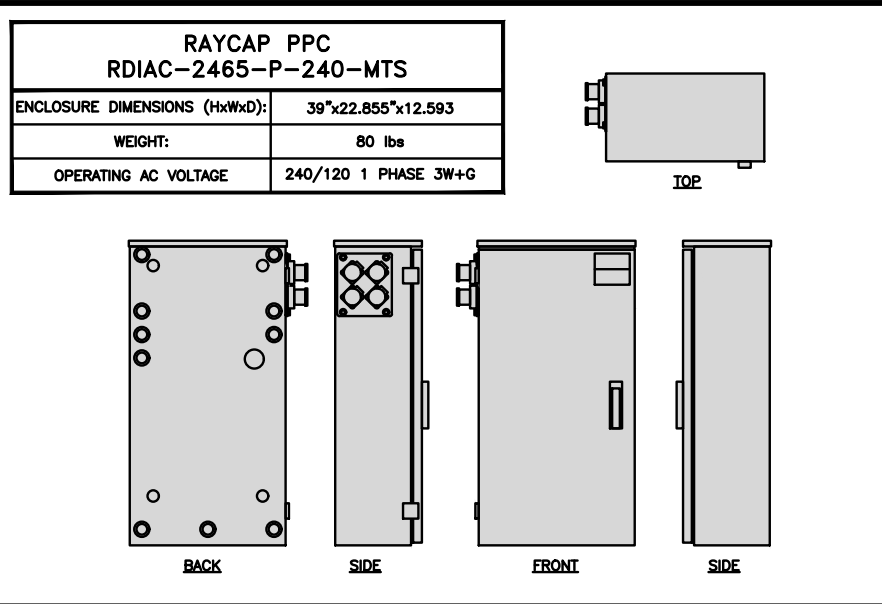

POWER PROTECTION CABINET (PPC) DETAIL NO SCALE 2

NOT USED NO SCALE 3

NOT USED NO SCALE 4

NOT USED NO SCALE 5

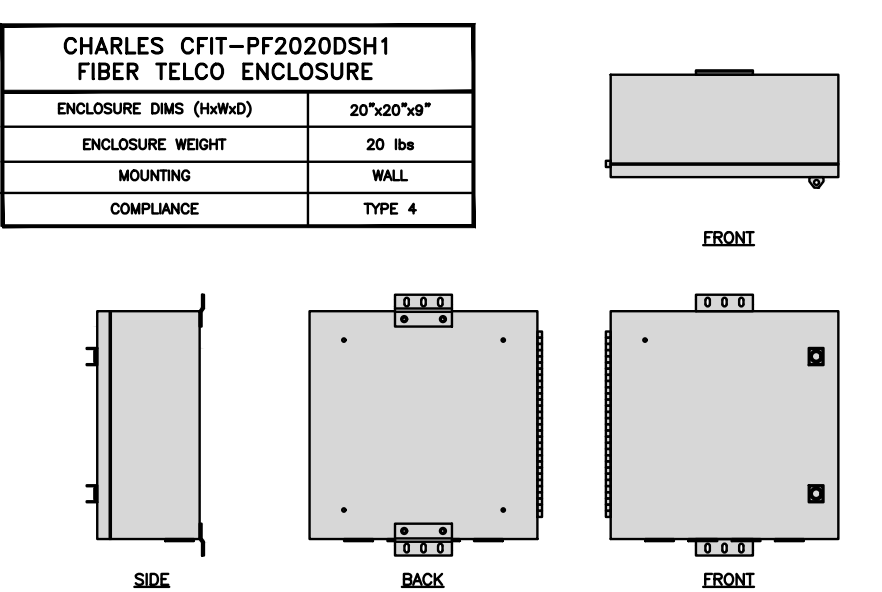

FIBER TELCO ENCLOSURE DETAIL NO SCALE 6

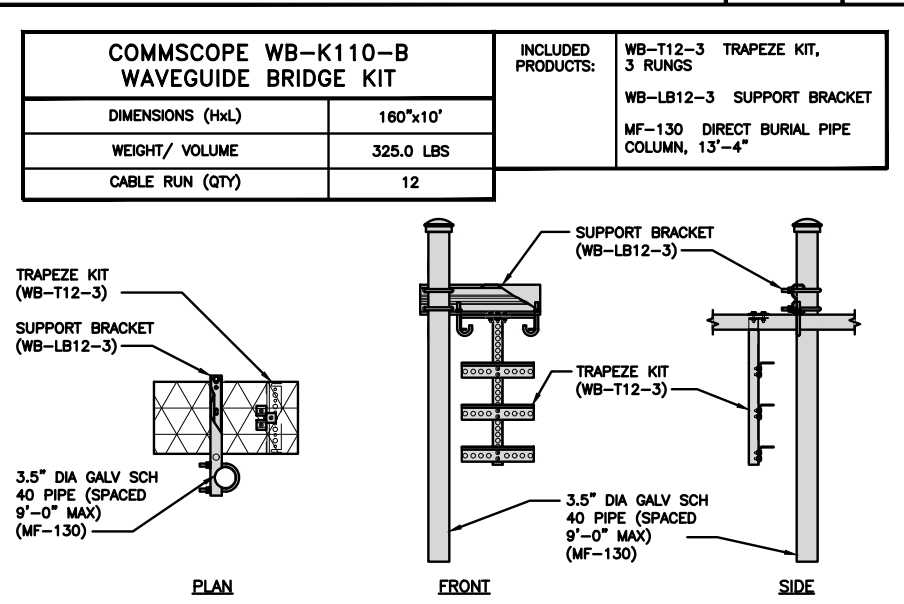

ICE BRIDGE DETAIL NO SCALE 7

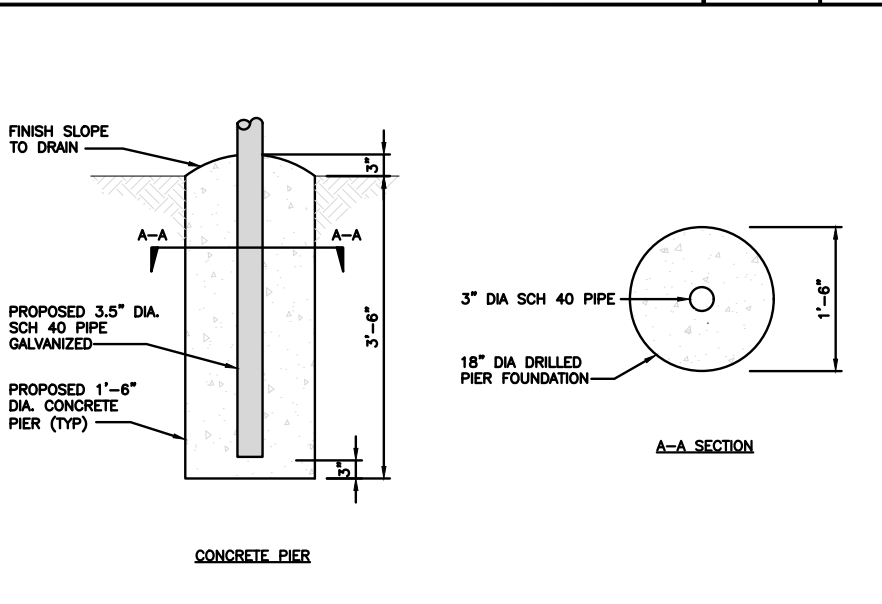

TYPICAL ICE BRIDGE CONCRETE PIER DETAIL NO SCALE 8

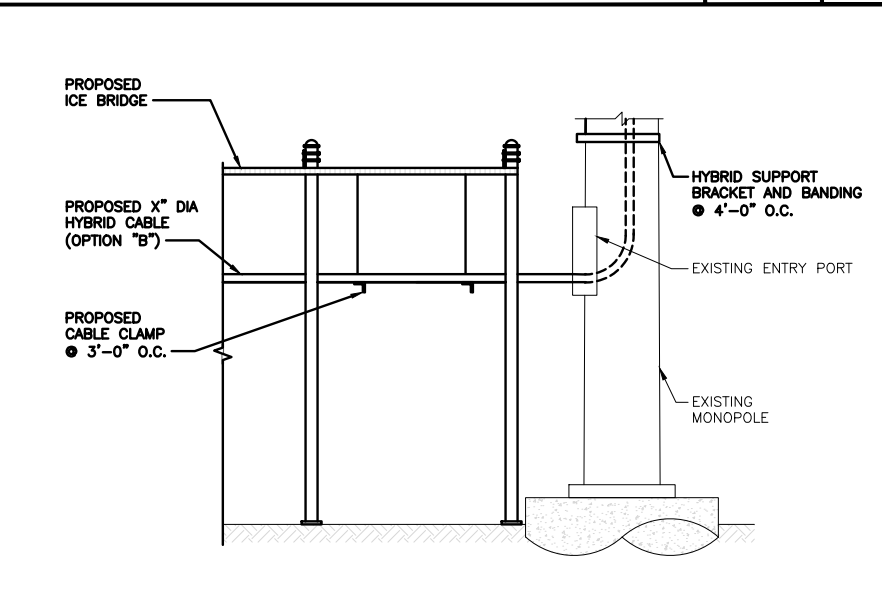

HYBRID CABLE RUN NO SCALE 9

5701 SOUTH SANTA FE DRIVE
LITTLETON, CO 80120

10 PRESIDENTIAL WAY
WOBURN, MA 01801

1717 S. BOULDER
SUITE 300
TULSA, OK 74119
PH: (918) 587-4630
www.btgrp.com

8/27/21

B&T ENGINEERING, INC.

IT IS A VIOLATION OF LAW FOR ANY PERSON, UNLESS THEY ARE ACTING UNDER THE DIRECTION OF A LICENSED PROFESSIONAL ENGINEER, TO ALTER THIS DOCUMENT.

DRAWN BY:	CHECKED BY:	APPROVED BY:
ANP	JCO	MDW

RFDS REV #: 1.0

PRELIMINARY DOCUMENTS

SUBMITTALS		
REV	DATE	DESCRIPTION
A	8/13/21	ISSUED FOR REVIEW
0	8/27/21	ISSUED FOR CONSTRUCTION

A&E PROJECT NUMBER
153984.001.01

DISH Wireless L.L.C.
PROJECT INFORMATION
MNDLH00051A
2810 FANTA REED RD
LA CROSSE, WI 54603

SHEET TITLE
EQUIPMENT DETAILS

SHEET NUMBER
A-4

PCTEL GPSGL-TMG-SPI-40NCB	
DIMENSIONS (DIAxH) MM/INCH	81x184mm 3.2"x7.25"
WEIGHT W/ACCESSORIES	075 lbs
CONNECTOR	N-FEMALE
FREQUENCY RANGE	1590 ± 30MHz

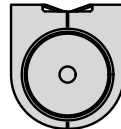

TOP

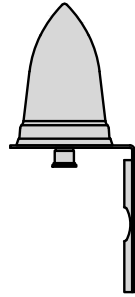

BACK

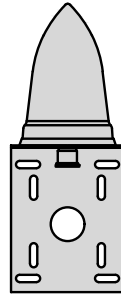

SIDE

GPS DETAIL

NO SCALE

1

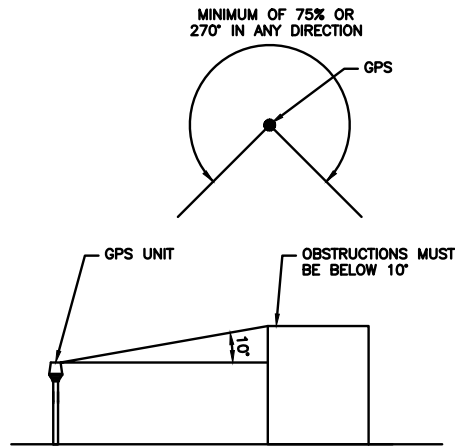

GPS MINIMUM SKY VIEW REQUIREMENTS

NO SCALE

2

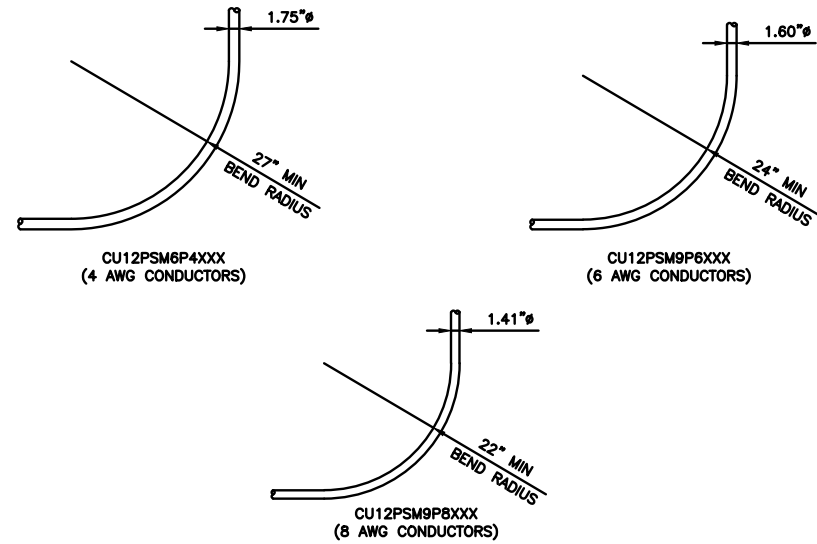

CABLES UNLIMITED HYBRID CABLE
MINIMUM BEND RADIUS

NO SCALE

3

NOT USED

NO SCALE

4

NOT USED

NO SCALE

5

NOT USED

NO SCALE

6

NOT USED

NO SCALE

7

NOT USED

NO SCALE

8

NOT USED

NO SCALE

9



5701 SOUTH SANTA FE DRIVE
LITTLETON, CO 80120



B&T ENGINEERING, INC.

IT IS A VIOLATION OF LAW FOR ANY PERSON, UNLESS THEY ARE ACTING UNDER THE DIRECTION OF A LICENSED PROFESSIONAL ENGINEER, TO ALTER THIS DOCUMENT.

DRAWN BY:	CHECKED BY:	APPROVED BY:
ANP	JCO	MDW

RFDS REV #: 1.0

PRELIMINARY DOCUMENTS

SUBMITTALS		
REV	DATE	DESCRIPTION
A	8/13/21	ISSUED FOR REVIEW
0	8/27/21	ISSUED FOR CONSTRUCTION

A&E PROJECT NUMBER
153984.001.01

DISH Wireless L.L.C.
PROJECT INFORMATION
MNDLH00051A
2810 FANTA REED RD
LA CROSSE, WI 54603

SHEET TITLE
EQUIPMENT DETAILS

SHEET NUMBER
A-5

FUJITSU TRIPLE BAND TA08025-B605	
DIMENSIONS (HxWxD)	14.9"x15.7"x9"
WEIGHT	74.95 lbs
CONNECTOR TYPE	4.3-10 RF CONNECTOR
POWER SUPPLY	DC -58~-36V

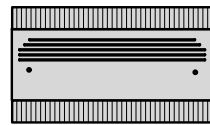

PLAN

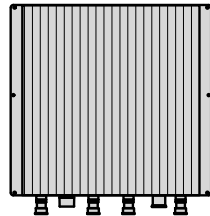

BACK

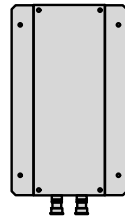

SIDE

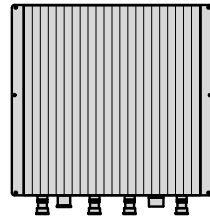

FRONT

RRH DETAIL

NO SCALE

1

FUJITSU DUAL BAND TA08025-B604	
DIMENSIONS (HxWxD)	14.9"x15.7"x7.8"
WEIGHT	63.9 lbs
CONNECTOR TYPE	4.3-10 RF CONNECTOR
POWER SUPPLY	DC -58~-36V

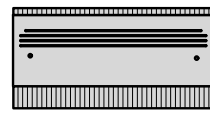

PLAN

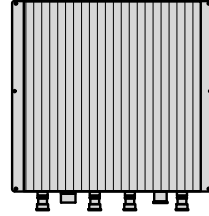

BACK

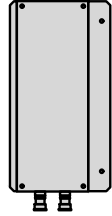

SIDE

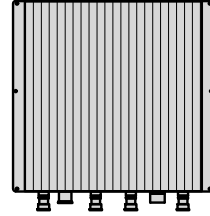

FRONT

RRH DETAIL

NO SCALE

2

SABRE DOUBLE Z-BRACKET C10123155	
DIMENSIONS (HxWxD) (1 BRACKET)	5"x20"x1-13/16"
WEIGHT (FULL ASSEMBLY)	35.79 lbs
PACKAGE QUANTITY	4

#	DESCRIPTION
1	PLATE, CHANNEL BRACKET
2	RRH Z BRACKET, 3/16"
3	THREADED ROD ASSEMBLY 1/2"x12"

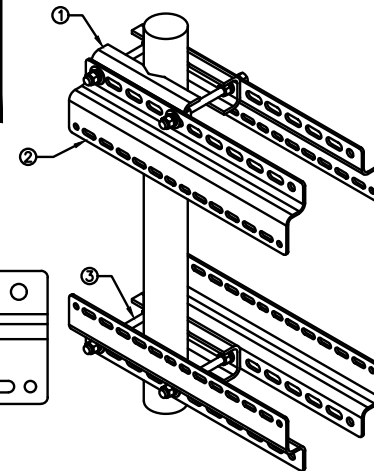
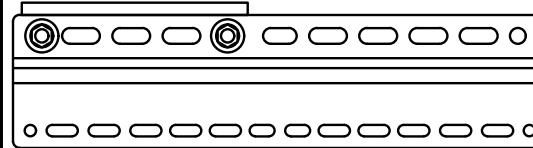

NOTE:
OR DISH Wireless L.L.C.
APPROVED EQUIVALENT

RRH MOUNT DETAIL

NO SCALE

3

JMA MX08FRO665-21	
DIMENSIONS (HxWxD)	72"x20.0"x8.0"
RF PORTS, CONNECTOR TYPE	8 x 4.3-10 FEMALE
WEIGHT	64.5 lbs
WEIGHT WITH BRACKETS	82.5 lbs

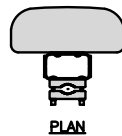

PLAN

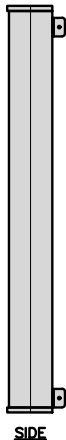

SIDE

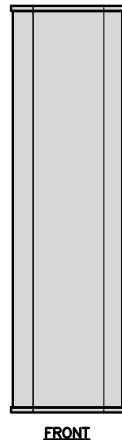

FRONT

ANTENNA DETAIL

NO SCALE

4

JMA ANTENNA MOUNT BRACKET #91900318	
TOTAL WEIGHT (WITH BRACKETS)	18 lbs (8.18 Kg)
POLE DIAMETER RANGE	2.5" TO 4.5"

NOTE:
KIT #91900318: TOP AND BOTTOM BRACKETS
FOR 4-, 6-, AND 8-FOOT ANTENNAS
ANTENNA BRACKET NOT PART OF KIT

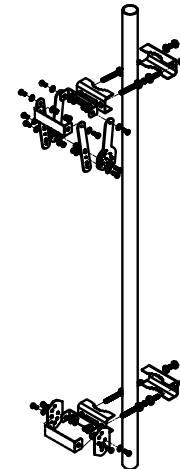

NOTE:
OR DISH Wireless L.L.C.
APPROVED EQUIVALENT

ANTENNA BRACKET DETAIL

NO SCALE

6

RAYCAP RDIDC-9181-PF-48 DC SURGE PROTECTION (OVP)	
DIMENSIONS (HxWxD)	18.98"x14.39"x8.15"
WEIGHT	21.82 LBS



PLAN

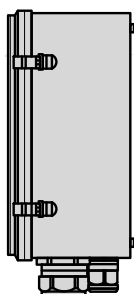

SIDE

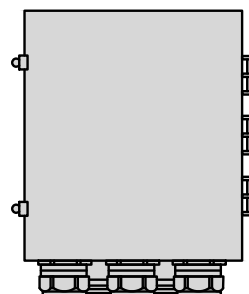

BACK

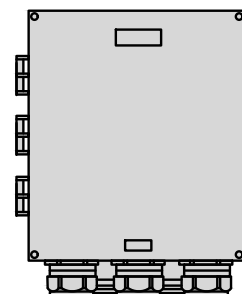

FRONT

SURGE SUPPRESSION DETAIL (OVP)

NO SCALE

7

COMMSCOPE XP-2040 CROSSOVER PLATE	
DIMENSIONS (HxW)	10"x12"
WEIGHT	11 lbs

NOTE:
OR DISH Wireless L.L.C.
APPROVED EQUIVALENT

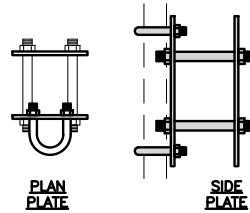

PLAN
U-BOLT

SIDE
U-BOLT

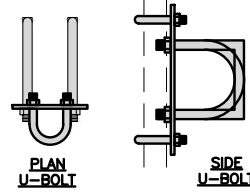

PLAN
U-BOLT

SIDE
U-BOLT

RRH/OVP MOUNT DETAIL

NO SCALE

8

SITEPRO1 SNP8HR-396 SNUB-NOSE PLATFORM	
FACE SIZE	8'-0"
WEIGHT	1786.28 LB
ANTENNA PIPE MOUNTS	(6) 2-3/8" O.D.

NOTE:
OR DISH Wireless L.L.C.
APPROVED EQUIVALENT

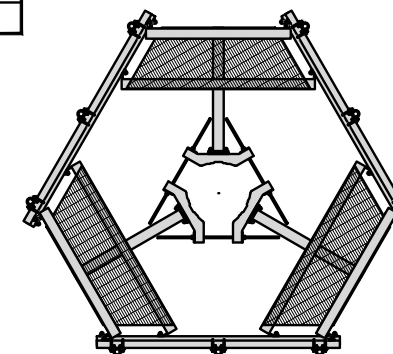
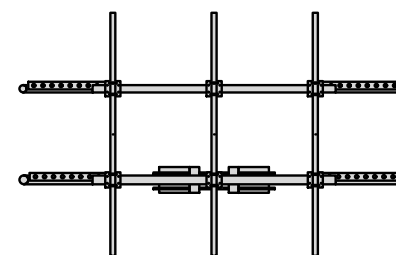

ANTENNA PLATFORM DETAIL

NO SCALE

9

dish
wireless.

5701 SOUTH SANTA FE DRIVE
LITTLETON, CO 80120

AMERICAN TOWER
10 PRESIDENTIAL WAY
WOBURN, MA 01801

B+T GRP
1717 S. BOULDER
SUITE 300
TULSA, OK 74119
PH: (918) 587-4630
www.btgrp.com



B&T ENGINEERING, INC.

IT IS A VIOLATION OF LAW FOR ANY PERSON,
UNLESS THEY ARE ACTING UNDER THE DIRECTION
OF A LICENSED PROFESSIONAL ENGINEER,
TO ALTER THIS DOCUMENT.

DRAWN BY: CHECKED BY: APPROVED BY:

ANP JCO MDW

RFDS REV #: 1.0

**PRELIMINARY
DOCUMENTS**

SUBMITTALS		
REV	DATE	DESCRIPTION
A	8/13/21	ISSUED FOR REVIEW
0	8/27/21	ISSUED FOR CONSTRUCTION

A&E PROJECT NUMBER
153984.001.01

DISH Wireless L.L.C.
PROJECT INFORMATION

MNDLH00051A
2810 FANTA REED RD
LA CROSSE, WI 54603

SHEET TITLE
EQUIPMENT DETAILS

SHEET NUMBER

A-6

FINAL POWER OR FIBER DESIGN NOT AVAILABLE AT TIME OF ISSUE

NOTES

1. CONTRACTOR SHALL FIELD VERIFY ALL PROPOSED UNDERGROUND UTILITY CONDUIT ROUTE.
2. ANTENNAS AND MOUNTS OMITTED FOR CLARITY.

DC POWER WIRING SHALL BE COLOR CODED AT EACH END FOR IDENTIFYING +24V AND -48V CONDUCTORS. RED MARKINGS SHALL IDENTIFY +24V AND BLUE MARKINGS SHALL IDENTIFY -48V.

1. CONTRACTOR SHALL INSPECT THE EXISTING CONDITIONS PRIOR TO SUBMITTING A BID. ANY QUESTIONS ARISING DURING THE BID PERIOD IN REGARDS TO THE CONTRACTOR'S FUNCTIONS, THE SCOPE OF WORK, OR ANY OTHER ISSUE RELATED TO THIS PROJECT SHALL BE BROUGHT UP DURING THE BID PERIOD WITH THE PROJECT MANAGER FOR CLARIFICATION, NOT AFTER THE CONTRACT HAS BEEN AWARDED.
2. ALL ELECTRICAL WORK SHALL BE DONE IN ACCORDANCE WITH CURRENT NATIONAL ELECTRICAL CODES AND ALL STATE AND LOCAL CODES, LAWS, AND ORDINANCES. PROVIDE ALL COMPONENTS AND WIRING SIZES AS REQUIRED TO MEET NEC STANDARDS.
3. LOCATION OF EQUIPMENT, CONDUIT AND DEVICES SHOWN ON THE DRAWINGS ARE APPROXIMATE AND SHALL BE COORDINATED WITH FIELD CONDITIONS PRIOR TO CONSTRUCTION.
4. CONDUIT ROUGH-IN SHALL BE COORDINATED WITH THE MECHANICAL EQUIPMENT TO AVOID LOCATION CONFLICTS. VERIFY WITH THE MECHANICAL EQUIPMENT CONTRACTOR AND COMPLY AS REQUIRED.
5. CONTRACTOR SHALL PROVIDE ALL BREAKERS, CONDUITS AND CIRCUITS AS REQUIRED FOR A COMPLETE SYSTEM.
6. CONTRACTOR SHALL PROVIDE PULL BOXES AND JUNCTION BOXES AS REQUIRED BY THE NEC ARTICLE 314.
7. CONTRACTOR SHALL PROVIDE ALL STRAIN RELIEF AND CABLE SUPPORTS FOR ALL CABLE ASSEMBLIES. INSTALLATION SHALL BE IN ACCORDANCE WITH MANUFACTURER'S SPECIFICATIONS AND RECOMMENDATIONS.
8. ALL DISCONNECTS AND CONTROLLING DEVICES SHALL BE PROVIDED WITH ENGRAVED PHENOLIC NAMEPLATES INDICATING EQUIPMENT CONTROLLED, BRANCH CIRCUITS INSTALLED ON, AND PANEL FIELD LOCATIONS FED FROM.
9. INSTALL AN EQUIPMENT GROUNDING CONDUCTOR IN ALL CONDUITS PER THE SPECIFICATIONS AND NEC 250. THE EQUIPMENT GROUNDING CONDUCTORS SHALL BE BONDED AT ALL JUNCTION BOXES, PULL BOXES, AND ALL DISCONNECT SWITCHES, AND EQUIPMENT CABINETS.
10. ALL NEW MATERIAL SHALL HAVE A U.L. LABEL.
11. PANEL SCHEDULE LOADING AND CIRCUIT ARRANGEMENTS REFLECT POST-CONSTRUCTION EQUIPMENT.
12. CONTRACTOR SHALL BE RESPONSIBLE FOR AS-BUILT PANEL SCHEDULE AND SITE DRAWINGS.
13. ALL TRENCHES IN COMPOUND TO BE HAND DUG
14. THE SURVEY PROVIDED ON THIS SHEET IS PROVIDED FOR REFERENCE ONLY, THE UTILITY ROUTE AND EXISTING EASEMENTS MUST BE VERIFIED PRIOR TO CONSTRUCTION.



5701 SOUTH SANTA FE DRIVE
LITTLETON, CO 80120



B&T ENGINEERING, INC.

IT IS A VIOLATION OF LAW FOR ANY PERSON, UNLESS THEY ARE ACTING UNDER THE DIRECTION OF A LICENSED PROFESSIONAL ENGINEER, TO ALTER THIS DOCUMENT.

DRAWN BY: ANP
CHECKED BY: JCO
APPROVED BY: MDW

RFDS REV #: 1.0

PRELIMINARY DOCUMENTS

SUBMITTALS		
REV	DATE	DESCRIPTION
A	8/13/21	ISSUED FOR REVIEW
0	8/27/21	ISSUED FOR CONSTRUCTION

A&E PROJECT NUMBER
153984.001.01

DISH Wireless L.L.C.
PROJECT INFORMATION

MNDLH00051A
2810 FANTA REED RD
LA CROSSE, WI 54603

SHEET TITLE
ELECTRICAL/FIBER ROUTE
PLAN AND NOTES

SHEET NUMBER
E-1

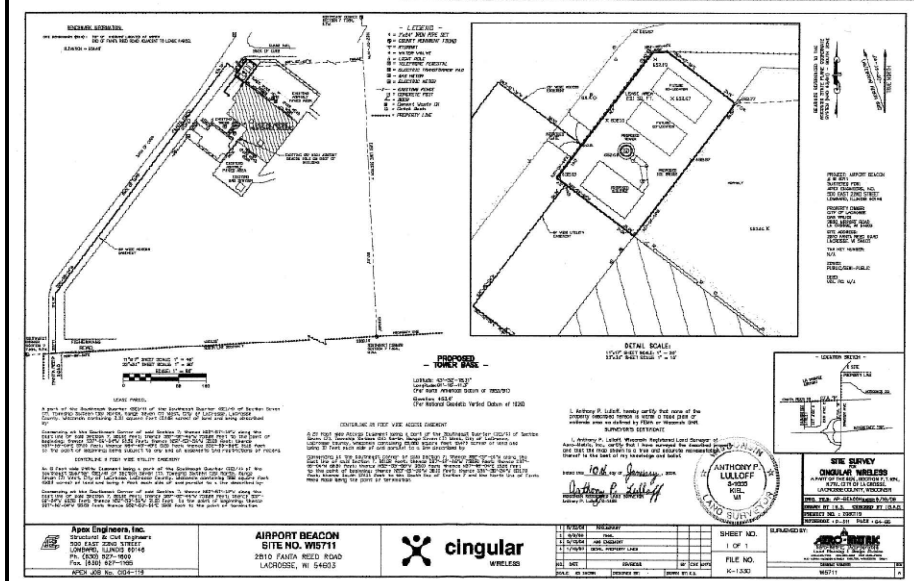
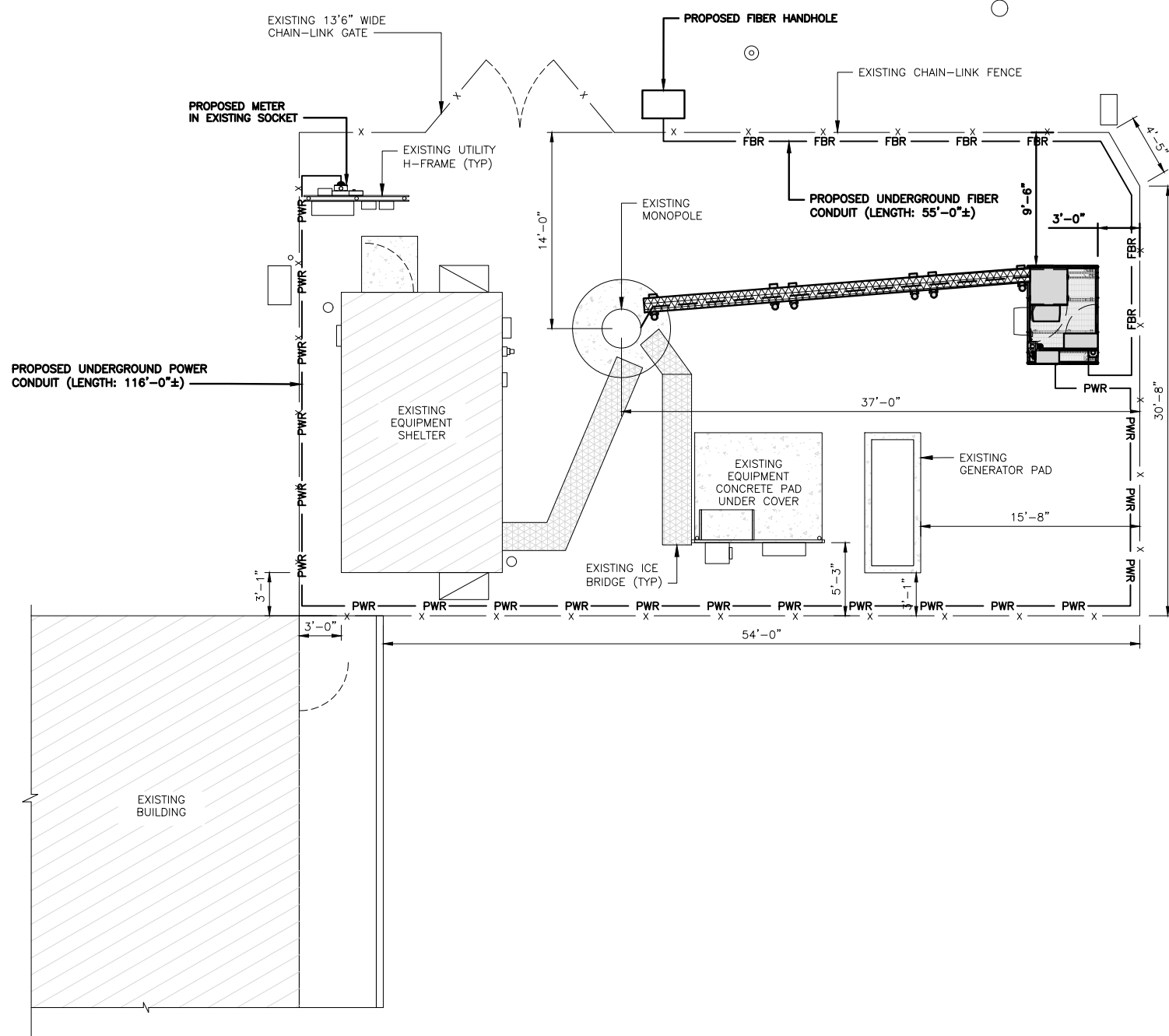

UTILITY ROUTE PLAN

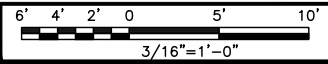

1

ELECTRICAL NOTES

NO SCALE

2

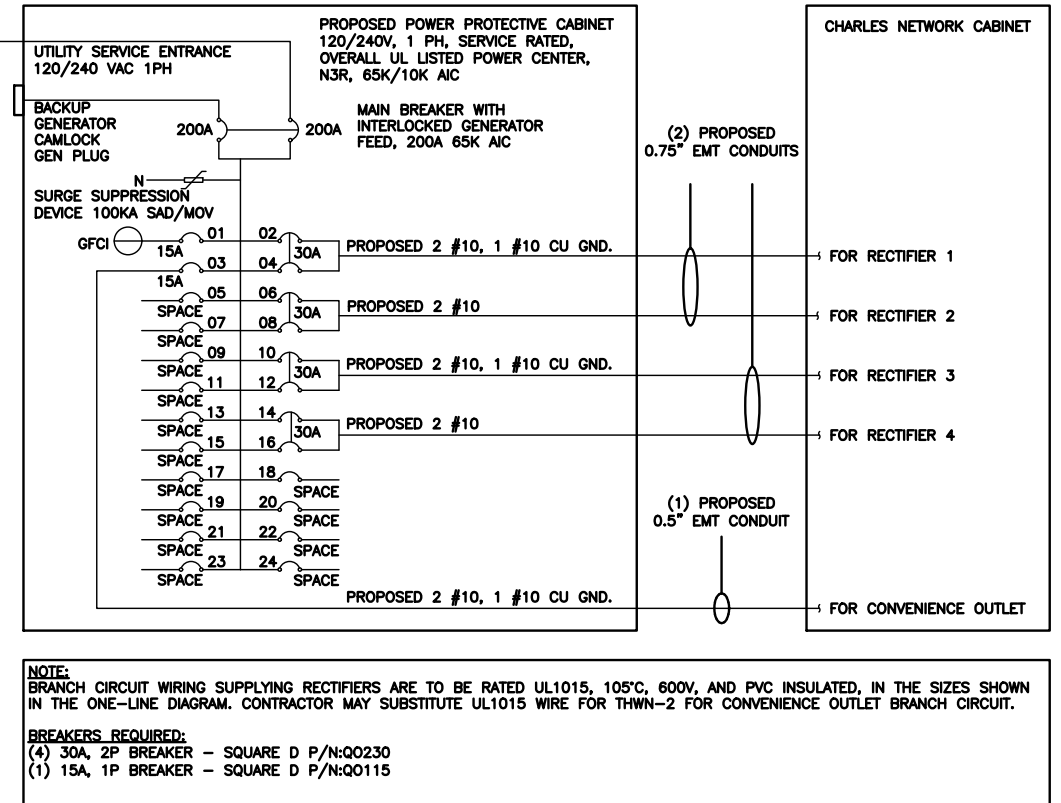
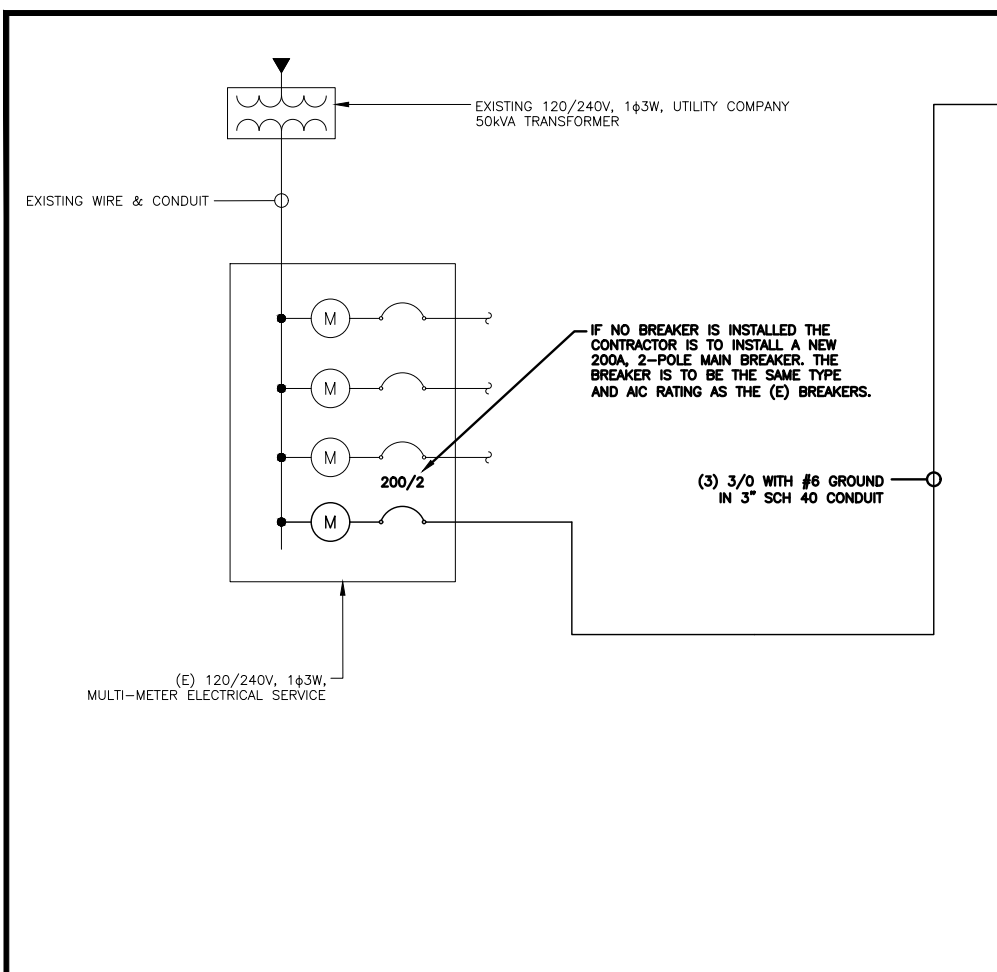

NOTE:
BRANCH CIRCUIT WIRING SUPPLYING RECTIFIERS ARE TO BE RATED UL1015, 105°C, 600V, AND PVC INSULATED, IN THE SIZES SHOWN IN THE ONE-LINE DIAGRAM. CONTRACTOR MAY SUBSTITUTE UL1015 WIRE FOR THWN-2 FOR CONVENIENCE OUTLET BRANCH CIRCUIT.

BREAKERS REQUIRED:
(4) 30A, 2P BREAKER - SQUARE D P/N:Q0230
(1) 15A, 1P BREAKER - SQUARE D P/N:Q0115

NOTES

THE (2) CONDUITS WITH (4) CURRENT CARRYING CONDUCTORS EACH, SHALL APPLY THE ADJUSTMENT FACTOR OF 80% PER 2014/17 NEC TABLE 310.15(B)(3)(g) OR 2020 NEC TABLE 310.15(C)(1) FOR UL1015 WIRE.

#12 FOR 15A-20A/1P BREAKER: 0.8 x 30A = 24.0A
#10 FOR 25A-30A/2P BREAKER: 0.8 x 40A = 32.0A
#8 FOR 35A-40A/2P BREAKER: 0.8 x 55A = 44.0A
#6 FOR 45A-60A/2P BREAKER: 0.8 x 75A = 60.0A

CONDUIT SIZING: AT 40% FILL PER NEC CHAPTER 9, TABLE 4, ARTICLE 358.
0.5" CONDUIT - 0.122 SQ. IN AREA
0.75" CONDUIT - 0.213 SQ. IN AREA
2.0" CONDUIT - 1.316 SQ. IN AREA
3.0" CONDUIT - 2.907 SQ. IN AREA

CABINET CONVENIENCE OUTLET CONDUCTORS (1 CONDUIT): USING THWN-2, CU.
#10 - 0.0211 SQ. IN X 2 = 0.0422 SQ. IN
#10 - 0.0211 SQ. IN X 1 = 0.0211 SQ. IN <GROUND
TOTAL = 0.0633 SQ. IN

0.5" EMT CONDUIT IS ADEQUATE TO HANDLE THE TOTAL OF (3) WIRES, INCLUDING GROUND WIRE, AS INDICATED ABOVE.

RECTIFIER CONDUCTORS (2 CONDUITS): USING UL1015, CU.
#10 - 0.0266 SQ. IN X 4 = 0.1064 SQ. IN
#10 - 0.0082 SQ. IN X 1 = 0.0082 SQ. IN <BARE GROUND
TOTAL = 0.1146 SQ. IN

0.75" EMT CONDUIT IS ADEQUATE TO HANDLE THE TOTAL OF (5) WIRES, INCLUDING GROUND WIRE, AS INDICATED ABOVE.

PPC FEED CONDUCTORS (1 CONDUIT): USING THWN, CU.
3/0 - 0.2679 SQ. IN X 3 = 0.8037 SQ. IN
#6 - 0.0507 SQ. IN X 1 = 0.0507 SQ. IN <GROUND
TOTAL = 0.8544 SQ. IN

3.0" SCH 40 PVC CONDUIT IS ADEQUATE TO HANDLE THE TOTAL OF (4) WIRES, INCLUDING GROUND WIRE, AS INDICATED ABOVE.

PPC ONE-LINE DIAGRAM

NO SCALE 1

PROPOSED CHARLES PANEL SCHEDULE										
LOAD SERVED	VOLT AMPS (WATTS)		TRIP	CKT #	PHASE	CKT #	TRIP	VOLT AMPS (WATTS)		LOAD SERVED
	L1	L2						L1	L2	
PPC GFCI OUTLET	180	180	15A	1	A	2	30A	2880	2880	ABB/GE INFINITY RECTIFIER 1
CHARLES GFCI OUTLET			15A	3	B	4				
-SPACE-				5	A	6	30A	2880	2880	ABB/GE INFINITY RECTIFIER 2
-SPACE-				7	B	8				
-SPACE-				9	A	10	30A	2880	2880	ABB/GE INFINITY RECTIFIER 3
-SPACE-				11	B	12				
-SPACE-				13	A	14	30A	2880	2880	ABB/GE INFINITY RECTIFIER 4
-SPACE-				15	B	16				
-SPACE-				17	A	18				
-SPACE-				19	B	20				
-SPACE-				21	A	22				
-SPACE-				23	B	24				
VOLTAGE AMPS			180	180				11520	11520	
200A MCB, 1Φ, 24 SPACE, 120/240V					L1	L2				
MB RATING: 65,000 AIC					11700	11700			VOLTAGE AMPS	
					98	98			AMPS	
					98				MAX AMPS	
					123				MAX 125%	

PANEL SCHEDULE

NO SCALE 2

NOT USED

NO SCALE 3

dish wireless.

5701 SOUTH SANTA FE DRIVE
LITTLETON, CO 80120

AMERICAN TOWER
10 PRESIDENTIAL WAY
WOBURN, MA 01801

B+T GRP
1717 S. BOULDER
SUITE 300
TULSA, OK 74119
PH: (918) 587-4630
www.btgrp.com

Professional Engineer Seal
WISCONSIN
BRAD F.
MILANOWSKI
E-483126
TULSA, OK
PROFESSIONAL ENGINEER
8/27/21

B&T ENGINEERING, INC.

IT IS A VIOLATION OF LAW FOR ANY PERSON, UNLESS THEY ARE ACTING UNDER THE DIRECTION OF A LICENSED PROFESSIONAL ENGINEER, TO ALTER THIS DOCUMENT.

DRAWN BY: ANP
CHECKED BY: JCO
APPROVED BY: MDW

RFDS REV #: 1.0

PRELIMINARY DOCUMENTS

SUBMITTALS		
REV	DATE	DESCRIPTION
A	8/13/21	ISSUED FOR REVIEW
0	8/27/21	ISSUED FOR CONSTRUCTION

A&E PROJECT NUMBER
153984.001.01

DISH Wireless L.L.C.
PROJECT INFORMATION
MNDLH00051A
2810 FANTA REED RD
LA CROSSE, WI 54603

SHEET TITLE
ELECTRICAL ONE-LINE, FAULT
CALCS & PANEL SCHEDULE

SHEET NUMBER
E-3

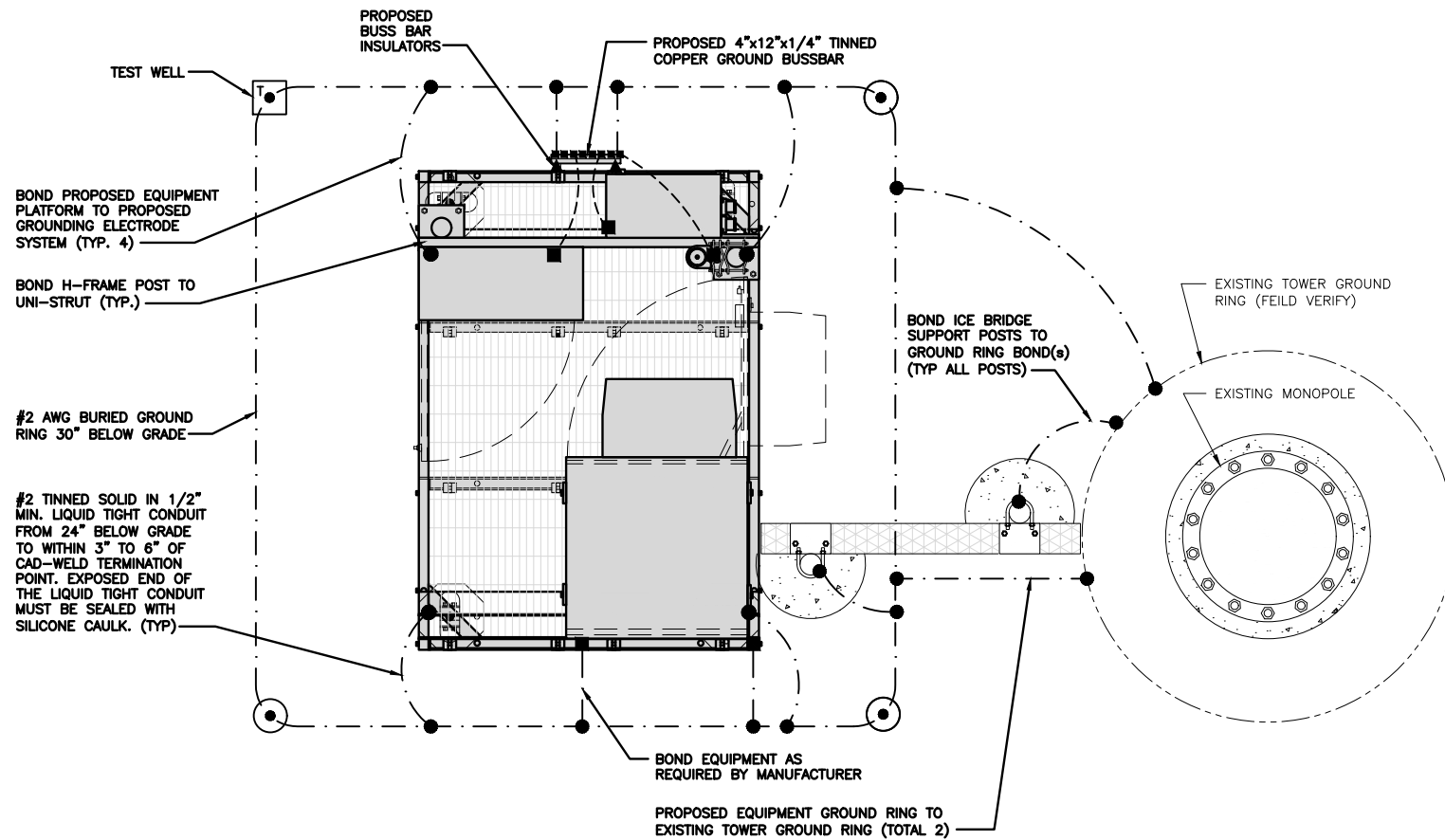

TYPICAL EQUIPMENT GROUNDING PLAN

NO SCALE 1

NOTES

1. ANTENNAS AND OVP SHOWN ARE GENERIC AND NOT REFERENCING TO A SPECIFIC MANUFACTURER. THIS LAYOUT IS FOR REFERENCE ONLY

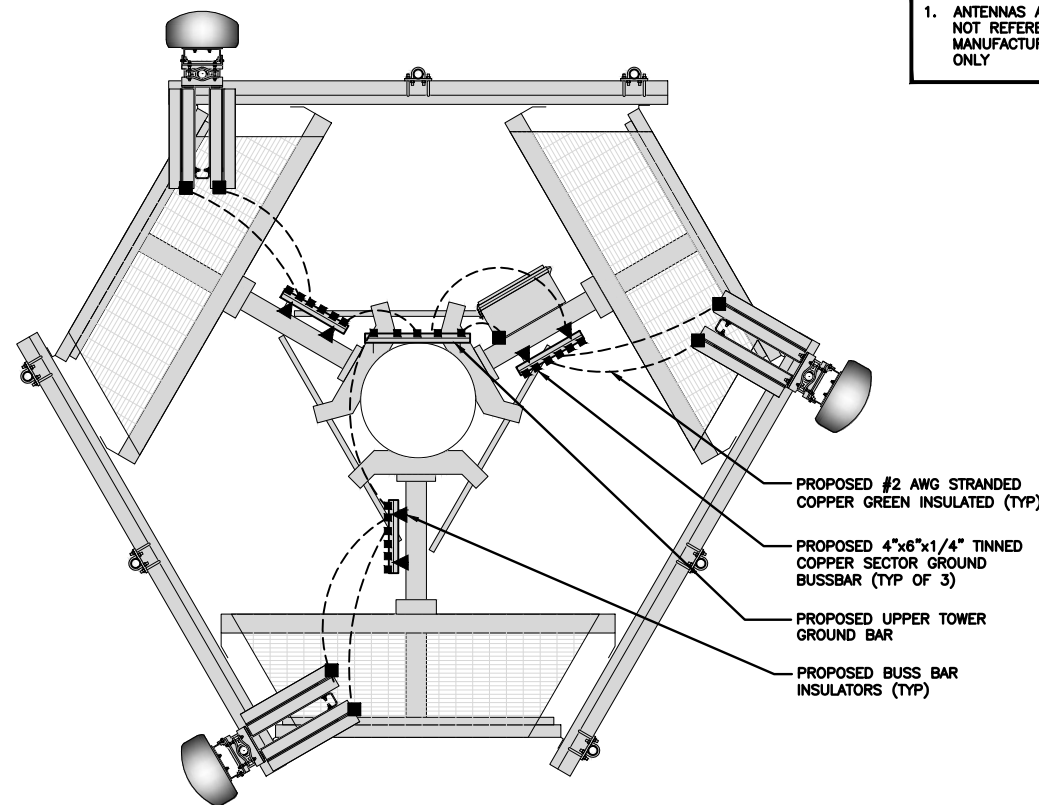

TYPICAL ANTENNA GROUNDING PLAN

NO SCALE 2

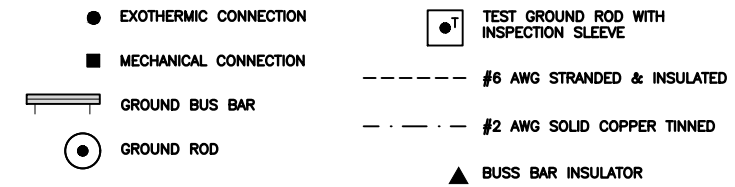

GROUNDING LEGEND

1. GROUNDING IS SHOWN DIAGRAMMATICALLY ONLY.
2. CONTRACTOR SHALL GROUND ALL EQUIPMENT AS A COMPLETE SYSTEM. GROUNDING SHALL BE IN COMPLIANCE WITH NEC SECTION 250 AND DISH Wireless L.L.C. GROUNDING AND BONDING REQUIREMENTS AND MANUFACTURER'S SPECIFICATIONS.
3. ALL GROUND CONDUCTORS SHALL BE COPPER; NO ALUMINUM CONDUCTORS SHALL BE USED.

GROUNDING KEY NOTES

- (A) EXTERIOR GROUND RING: #2 AWG SOLID COPPER, BURIED AT A DEPTH OF AT LEAST 30 INCHES BELOW GRADE, OR 6 INCHES BELOW THE FROST LINE AND APPROXIMATELY 24 INCHES FROM THE EXTERIOR WALL OR FOOTING.
- (B) TOWER GROUND RING: THE GROUND RING SYSTEM SHALL BE INSTALLED AROUND AN ANTENNA TOWER'S LEGS, AND/OR GUY ANCHORS. WHERE SEPARATE SYSTEMS HAVE BEEN PROVIDED FOR THE TOWER AND THE BUILDING, AT LEAST TWO BONDS SHALL BE MADE BETWEEN THE TOWER RING GROUND SYSTEM AND THE BUILDING RING GROUND SYSTEM USING MINIMUM #2 AWG SOLID COPPER CONDUCTORS.
- (C) INTERIOR GROUND RING: #2 AWG STRANDED GREEN INSULATED COPPER CONDUCTOR EXTENDED AROUND THE PERIMETER OF THE EQUIPMENT AREA. ALL NON-TELECOMMUNICATIONS RELATED METALLIC OBJECTS FOUND WITHIN A SITE SHALL BE GROUNDED TO THE INTERIOR GROUND RING WITH #6 AWG STRANDED GREEN INSULATED CONDUCTOR.
- (D) BOND TO INTERIOR GROUND RING: #2 AWG SOLID TINNED COPPER WIRE PRIMARY BONDS SHALL BE PROVIDED AT LEAST AT FOUR POINTS ON THE INTERIOR GROUND RING, LOCATED AT THE CORNERS OF THE BUILDING.
- (E) GROUND ROD: UL LISTED COPPER CLAD STEEL MINIMUM 1/2" DIAMETER BY EIGHT FEET LONG. GROUND RODS SHALL BE INSTALLED WITH INSPECTION SLEEVES. GROUND RODS SHALL BE DRIVEN TO THE DEPTH OF GROUND RING CONDUCTOR.
- (F) CELL REFERENCE GROUND BAR: POINT OF GROUND REFERENCE FOR ALL COMMUNICATIONS EQUIPMENT FRAMES. ALL BONDS ARE MADE WITH #2 AWG UNLESS NOTED OTHERWISE STRANDED GREEN INSULATED COPPER CONDUCTORS. BOND TO GROUND RING WITH (2) #2 SOLID TINNED COPPER CONDUCTORS.
- (G) HATCH PLATE GROUND BAR: BOND TO THE INTERIOR GROUND RING WITH TWO #2 AWG STRANDED GREEN INSULATED COPPER CONDUCTORS. WHEN A HATCH-PLATE AND A CELL REFERENCE GROUND BAR ARE BOTH PRESENT, THE CRGB MUST BE CONNECTED TO THE HATCH-PLATE AND TO THE INTERIOR GROUND RING USING (2) TWO #2 AWG STRANDED GREEN INSULATED COPPER CONDUCTORS EACH.
- (H) EXTERIOR CABLE ENTRY PORT GROUND BARS: LOCATED AT THE ENTRANCE TO THE CELL SITE BUILDING. BOND TO GROUND RING WITH A #2 AWG SOLID TINNED COPPER CONDUCTORS WITH AN EXOTHERMIC WELD AND INSPECTION SLEEVE.
- (I) TELCO GROUND BAR: BOND TO BOTH CELL REFERENCE GROUND BAR OR EXTERIOR GROUND RING.
- (J) FRAME BONDING: THE BONDING POINT FOR TELECOM EQUIPMENT FRAMES SHALL BE THE GROUND BUS THAT IS NOT ISOLATED FROM THE EQUIPMENTS METAL FRAMEWORK.
- (K) INTERIOR UNIT BONDS: METAL FRAMES, CABINETS AND INDIVIDUAL METALLIC UNITS LOCATED WITH THE AREA OF THE INTERIOR GROUND RING REQUIRE A #6 AWG STRANDED GREEN INSULATED COPPER BOND TO THE INTERIOR GROUND RING.
- (L) FENCE AND GATE GROUNDING: METAL FENCES WITHIN 7 FEET OF THE EXTERIOR GROUND RING OR OBJECTS BONDED TO THE EXTERIOR GROUND RING SHALL BE BONDED TO THE GROUND RING WITH A #2 AWG SOLID TINNED COPPER CONDUCTOR AT AN INTERVAL NOT EXCEEDING 25 FEET. BONDS SHALL BE MADE AT EACH GATE POST AND ACROSS GATE OPENINGS.
- (M) EXTERIOR UNIT BONDS: METALLIC OBJECTS, EXTERNAL TO OR MOUNTED TO THE BUILDING, SHALL BE BONDED TO THE EXTERIOR GROUND RING. USING #2 TINNED SOLID COPPER WIRE
- (N) ICE BRIDGE SUPPORTS: EACH ICE BRIDGE LEG SHALL BE BONDED TO THE GROUND RING WITH #2 AWG BARE TINNED COPPER CONDUCTOR. PROVIDE EXOTHERMIC WELDS AT BOTH THE ICE BRIDGE LEG AND BURIED GROUND RING.
- (O) DURING ALL DC POWER SYSTEM CHANGES INCLUDING DC SYSTEM CHANGE OUTS, RECTIFIER REPLACEMENTS OR ADDITIONS, BREAKER DISTRIBUTION CHANGES, BATTERY ADDITIONS, BATTERY REPLACEMENTS AND INSTALLATIONS OR CHANGES TO DC CONVERTER SYSTEMS IT SHALL BE REQUIRED THAT SERVICE CONTRACTORS VERIFY ALL DC POWER SYSTEMS ARE EQUIPPED WITH A MASTER DC SYSTEM RETURN GROUND CONDUCTOR FROM THE DC POWER SYSTEM COMMON RETURN BUS DIRECTLY CONNECTED TO THE CELL SITE REFERENCE GROUND BAR
- (P) TOWER TOP COLLECTOR BUSS BAR IS TO BE MECHANICALLY BONDED TO PROPOSED ANTENNA MOUNT COLLAR. REFER TO DISH Wireless L.L.C. GROUNDING NOTES.

GROUNDING KEY NOTES

NO SCALE 3



5701 SOUTH SANTA FE DRIVE
LITTLETON, CO 80120



B&T ENGINEERING, INC.

IT IS A VIOLATION OF LAW FOR ANY PERSON, UNLESS THEY ARE ACTING UNDER THE DIRECTION OF A LICENSED PROFESSIONAL ENGINEER, TO ALTER THIS DOCUMENT.

DRAWN BY: ANP CHECKED BY: JCO APPROVED BY: MDW

RFDS REV #: 1.0

PRELIMINARY DOCUMENTS

SUBMITTALS		
REV	DATE	DESCRIPTION
A	8/13/21	ISSUED FOR REVIEW
0	8/27/21	ISSUED FOR CONSTRUCTION

A&E PROJECT NUMBER
153984.001.01

DISH Wireless L.L.C.
PROJECT INFORMATION

MNDLH00051A
2810 FANTA REED RD
LA CROSSE, WI 54603

SHEET TITLE
GROUNDING PLANS
AND NOTES

SHEET NUMBER

G-1

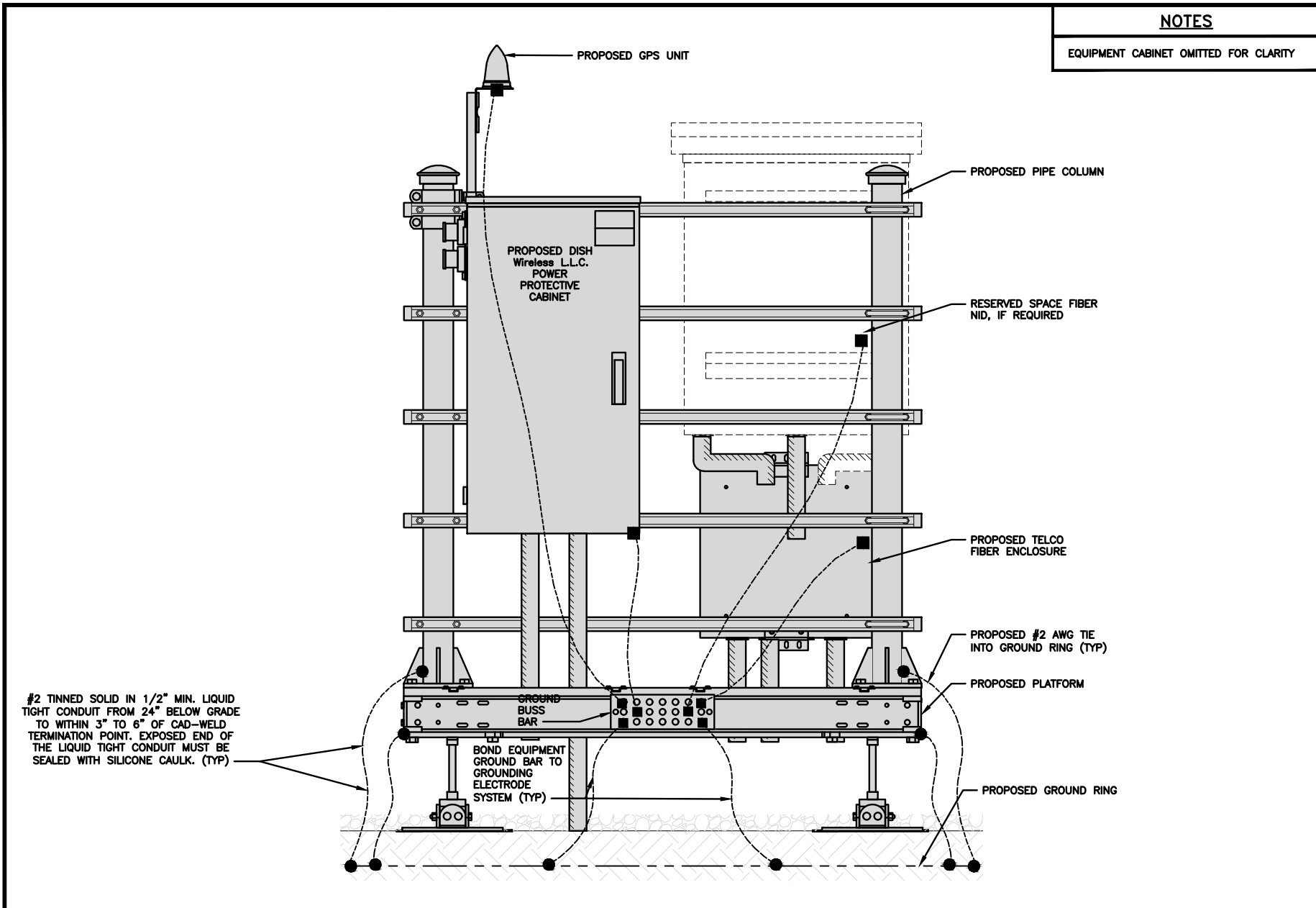

H-FRAME GROUNDING DETAIL

NO SCALE 1

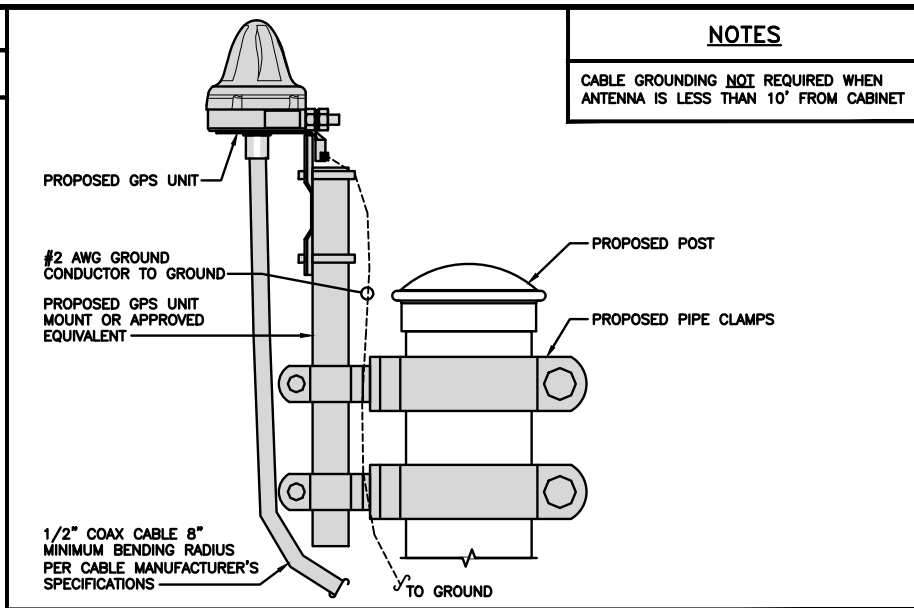

TYPICAL GPS UNIT GROUNDING

NO SCALE 2

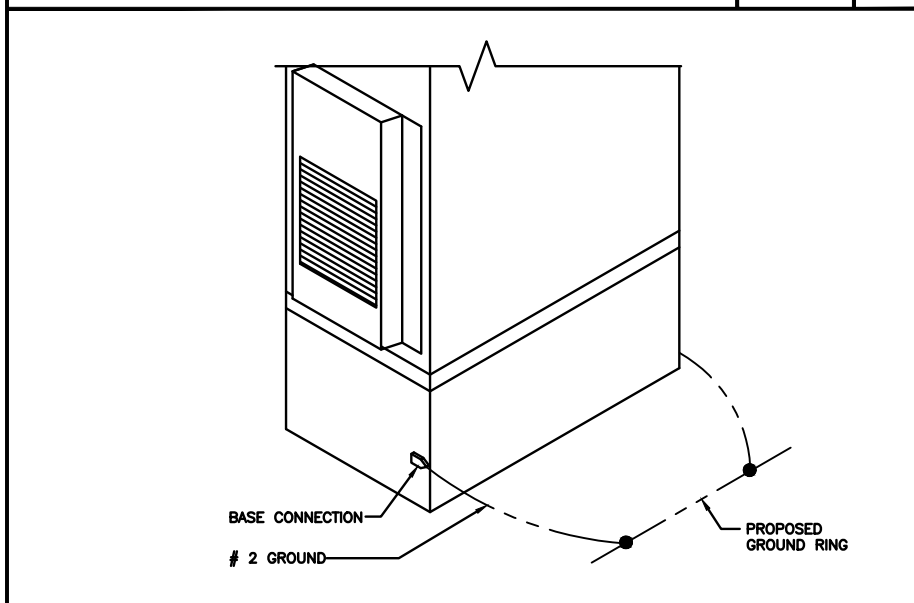

OUTDOOR CABINET GROUNDING

NO SCALE 3

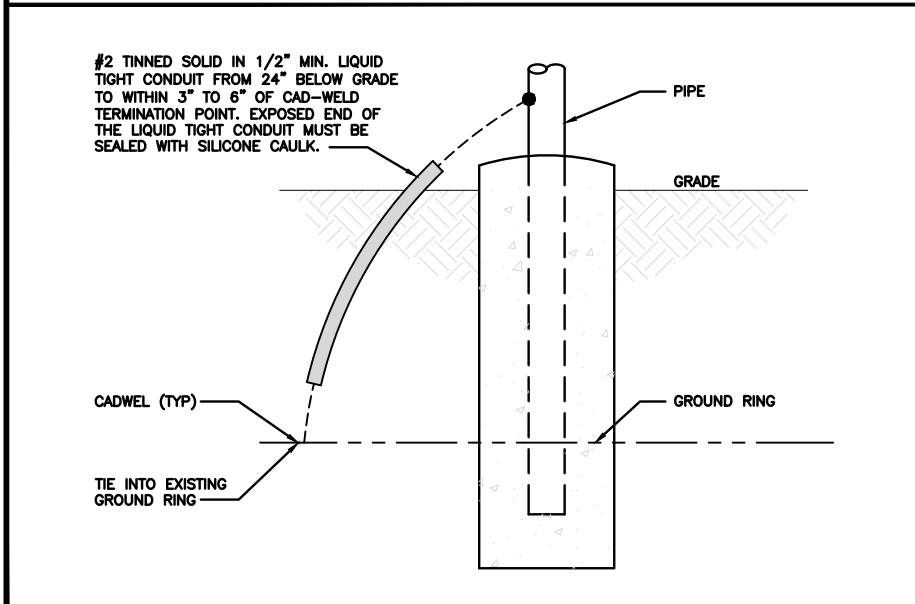

TRANSITIONING GROUND DETAIL

NO SCALE 4

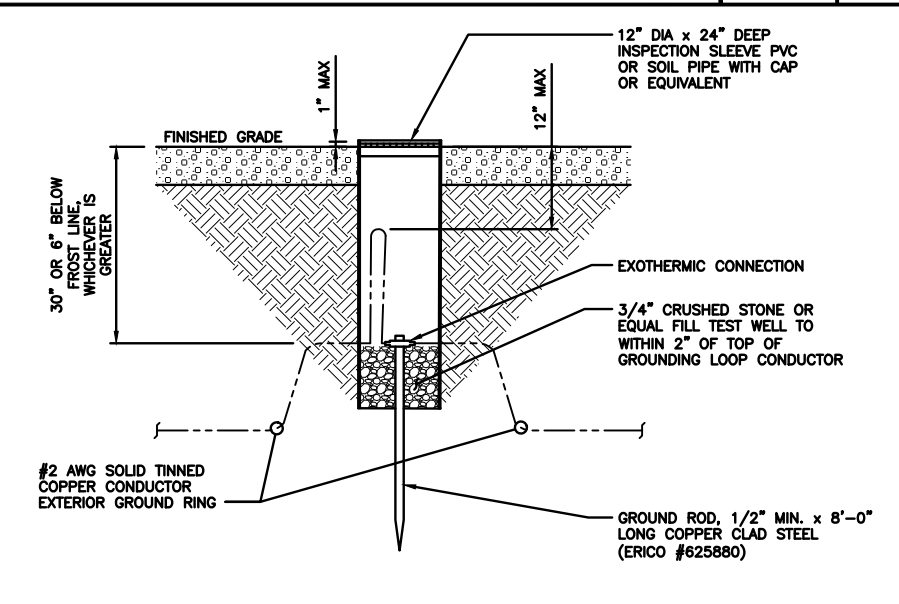

TYPICAL TEST GROUND ROD WITH INSPECTION SLEEVE

NO SCALE 5

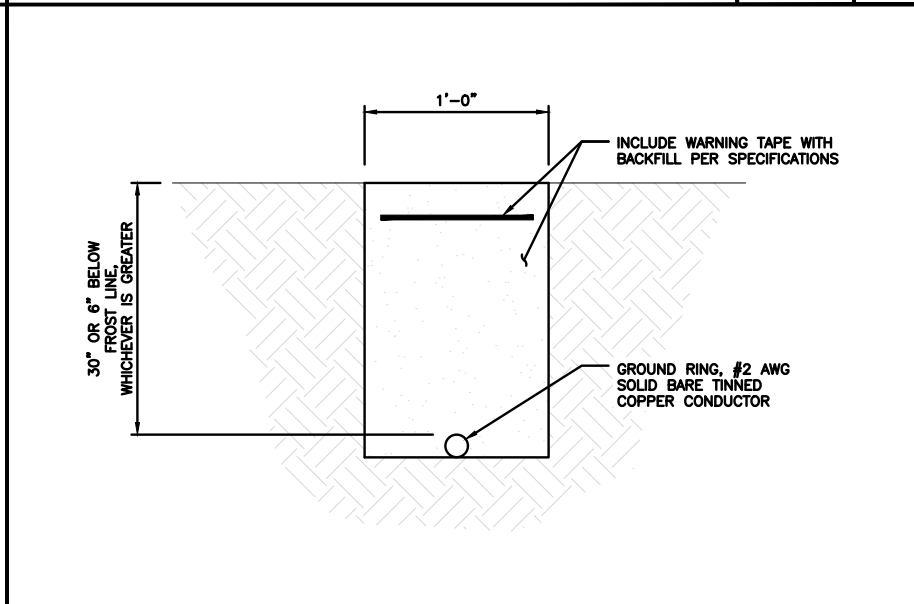

TYPICAL GROUND RING TRENCH

NO SCALE 6



5701 SOUTH SANTA FE DRIVE
LITTLETON, CO 80120

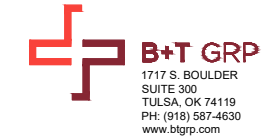

B&T ENGINEERING, INC.

IT IS A VIOLATION OF LAW FOR ANY PERSON, UNLESS THEY ARE ACTING UNDER THE DIRECTION OF A LICENSED PROFESSIONAL ENGINEER, TO ALTER THIS DOCUMENT.

DRAWN BY: ANP
CHECKED BY: JCO
APPROVED BY: MDW

RFDS REV #: 1.0

PRELIMINARY DOCUMENTS

SUBMITTALS		
REV	DATE	DESCRIPTION
A	8/13/21	ISSUED FOR REVIEW
0	8/27/21	ISSUED FOR CONSTRUCTION

A&E PROJECT NUMBER
153984.001.01

DISH Wireless L.L.C.
PROJECT INFORMATION

MNDLH00051A
2810 FANTA REED RD
LA CROSSE, WI 54603

SHEET TITLE
GROUNDING DETAILS

SHEET NUMBER

G-2

1. EXOTHERMIC WELD (2) TWO, #2 AWG BARE TINNED SOLID COPPER CONDUCTORS TO GROUND BAR. ROUTE CONDUCTORS TO BURIED GROUND RING AND PROVIDE PARALLEL EXOTHERMIC WELD.
2. ALL EXTERIOR GROUNDING HARDWARE SHALL BE STAINLESS STEEL 3/8" DIAMETER OR LARGER. ALL HARDWARE 18-8 STAINLESS STEEL INCLUDING LOCK WASHERS, COAT ALL SURFACES WITH AN ANTI-OXIDANT COMPOUND BEFORE MATING.
3. FOR GROUND BOND TO STEEL ONLY: COAT ALL SURFACES WITH AN ANTI-OXIDANT COMPOUND BEFORE MATING.
4. DO NOT INSTALL CABLE GROUNDING KIT AT A BEND AND ALWAYS DIRECT GROUND CONDUCTOR DOWN TO GROUNDING BUS.
5. NUT & WASHER SHALL BE PLACED ON THE FRONT SIDE OF THE GROUND BAR AND BOLTED ON THE BACK SIDE.
6. ALL GROUNDING PARTS AND EQUIPMENT TO BE SUPPLIED AND INSTALLED BY CONTRACTOR.
7. THE CONTRACTOR SHALL BE RESPONSIBLE FOR INSTALLING ADDITIONAL GROUND BAR AS REQUIRED.
8. ENSURE THE WIRE INSULATION TERMINATION IS WITHIN 1/8" OF THE BARREL (NO SHINERS).

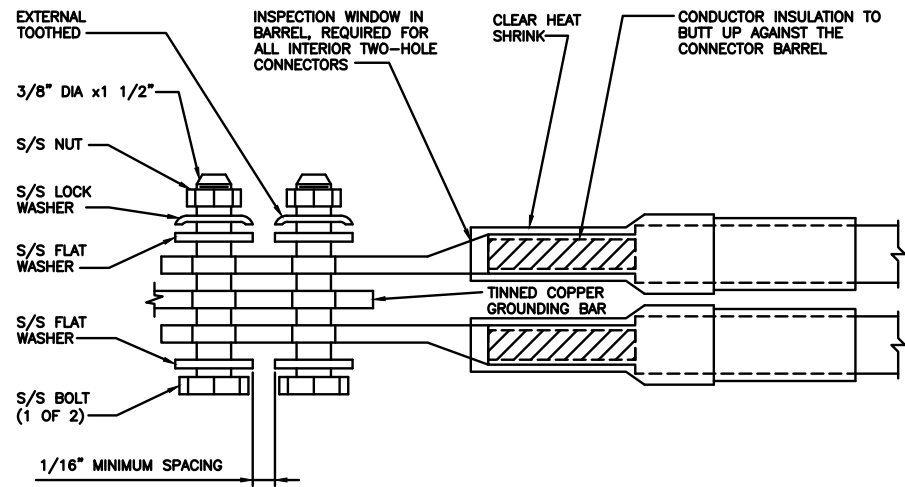
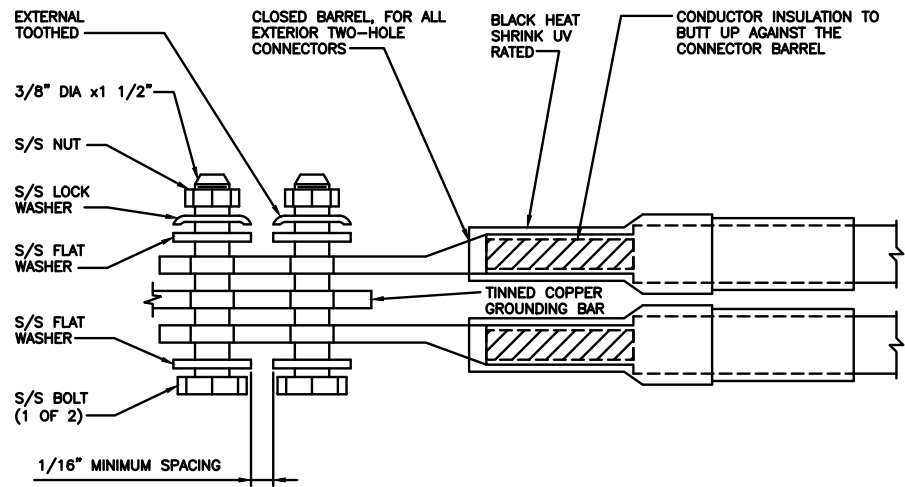

TYPICAL GROUNDING NOTES

NO SCALE 1

TYPICAL EXTERIOR TWO HOLE LUG

NO SCALE 2

TYPICAL INTERIOR TWO HOLE LUG

NO SCALE 3

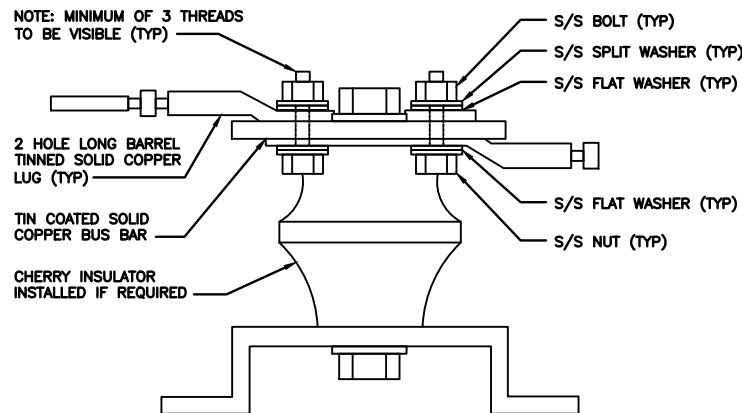

LUG DETAIL

NO SCALE 4

NOT USED

NO SCALE 5

NOT USED

NO SCALE 6

NOT USED

NO SCALE 7

NOT USED

NO SCALE 8

NOT USED

NO SCALE 9



5701 SOUTH SANTA FE DRIVE
LITTLETON, CO 80120



B&T ENGINEERING, INC.

IT IS A VIOLATION OF LAW FOR ANY PERSON, UNLESS THEY ARE ACTING UNDER THE DIRECTION OF A LICENSED PROFESSIONAL ENGINEER, TO ALTER THIS DOCUMENT.

DRAWN BY: ANP CHECKED BY: JCO APPROVED BY: MDW

RFDS REV #: 1.0

PRELIMINARY DOCUMENTS

SUBMITTALS		
REV	DATE	DESCRIPTION
A	8/13/21	ISSUED FOR REVIEW
0	8/27/21	ISSUED FOR CONSTRUCTION

A&E PROJECT NUMBER
153984.001.01

DISH Wireless L.L.C.
PROJECT INFORMATION
MNDLH00051A
2810 FANTA REED RD
LA CROSSE, WI 54603

SHEET TITLE
GROUNDING DETAILS

SHEET NUMBER
G-3

RF JUMPER COLOR CODING

3/4" TAPE WIDTHS WITH 3/4" SPACING

LOW-BAND RRH -
(600MHz N71 BASEBAND) +
(850MHz N26 BAND) +
(700MHz N29 BAND) - OPTIONAL PER MARKET

ADD FREQUENCY COLOR TO SECTOR BAND
(CBRS WILL USE YELLOW BANDS)

ALPHA RRH				BETA RRH				GAMMA RRH			
PORT 1 + SLANT	PORT 2 - SLANT	PORT 3 + SLANT	PORT 4 - SLANT	PORT 1 + SLANT	PORT 2 - SLANT	PORT 3 + SLANT	PORT 4 - SLANT	PORT 1 + SLANT	PORT 2 - SLANT	PORT 3 + SLANT	PORT 4 - SLANT
RED	RED	RED	RED	BLUE	BLUE	BLUE	BLUE	GREEN	GREEN	GREEN	GREEN
ORANGE	ORANGE	RED	RED	ORANGE	ORANGE	BLUE	BLUE	ORANGE	ORANGE	GREEN	GREEN
	WHITE (-) PORT	ORANGE	ORANGE		WHITE (-) PORT	ORANGE	ORANGE		WHITE (-) PORT	ORANGE	ORANGE
			WHITE (-) PORT				WHITE (-) PORT				WHITE (-) PORT

MID-BAND RRH -
(AWS BANDS N66+N70)

ADD FREQUENCY COLOR TO SECTOR BAND
(CBRS WILL USE YELLOW BANDS)

RED	RED	RED	RED	BLUE	BLUE	BLUE	BLUE	GREEN	GREEN	GREEN	GREEN
PURPLE	PURPLE	RED	RED	PURPLE	PURPLE	BLUE	BLUE	PURPLE	PURPLE	GREEN	GREEN
	WHITE (-) PORT	PURPLE	PURPLE		WHITE (-) PORT	PURPLE	PURPLE		WHITE (-) PORT	PURPLE	PURPLE
			WHITE (-) PORT				WHITE (-) PORT				WHITE (-) PORT

HYBRID/DISCREET CABLES

INCLUDE SECTOR BANDS BEING SUPPORTED
ALONG WITH FREQUENCY BANDS

EXAMPLE 1 - HYBRID, OR DISCREET, SUPPORTS
ALL SECTORS, BOTH LOW-BANDS AND MID-BANDS

EXAMPLE 2 - HYBRID, OR DISCREET, SUPPORTS
CBRS ONLY, ALL SECTORS

EXAMPLE 1	EXAMPLE 2	EXAMPLE 3
RED	RED	RED
BLUE	BLUE	
GREEN	GREEN	ORANGE
ORANGE	YELLOW	PURPLE
PURPLE		

FIBER JUMPERS TO RRHs

LOW-BAND RRH FIBER CABLES HAVE SECTOR
STRIPE ONLY

LOW BAND RRH	HIGH BAND RRH	LOW BAND RRH	HIGH BAND RRH	LOW BAND RRH	HIGH BAND RRH
RED	RED	BLUE	BLUE	GREEN	GREEN
	PURPLE		PURPLE		PURPLE

POWER CABLES TO RRHs

LOW-BAND RRH POWER CABLES HAVE SECTOR
STRIPE ONLY

LOW BAND RRH	HIGH BAND RRH	LOW BAND RRH	HIGH BAND RRH	LOW BAND RRH	HIGH BAND RRH
RED	RED	BLUE	BLUE	GREEN	GREEN
	PURPLE		PURPLE		PURPLE

RET MOTORS AT ANTENNAS

ANTENNA 1 LOW BAND/ "IN"	ANTENNA 1 HIGH BAND/ "IN"	ANTENNA 1 LOW BAND/ "IN"	ANTENNA 1 HIGH BAND/ "IN"	ANTENNA 1 LOW BAND/ "IN"	ANTENNA 1 HIGH BAND/ "IN"
RED	RED	BLUE	BLUE	GREEN	GREEN
	PURPLE		PURPLE		PURPLE

MICROWAVE RADIO LINKS

LINKS WILL HAVE A 1.5-2 INCH WHITE WRAP WITH
THE AZIMUTH COLOR OVERLAPPING IN THE MIDDLE.
ADD ADDITIONAL SECTOR COLOR BANDS FOR EACH
ADDITIONAL MW RADIO.

MICROWAVE CABLES WILL REQUIRE P-TOUCH
LABELS INSIDE THE CABINET TO IDENTIFY THE
LOCAL AND REMOTE SITE ID'S

FORWARD AZIMUTH OF 0-120 DEGREES		FORWARD AZIMUTH OF 120-240 DEGREES		FORWARD AZIMUTH OF 240-360 DEGREES	
PRIMARY	SECONDARY	PRIMARY	SECONDARY	PRIMARY	SECONDARY
WHITE	WHITE	WHITE	WHITE	WHITE	WHITE
RED	RED	BLUE	BLUE	GREEN	GREEN
WHITE	WHITE	WHITE	WHITE	WHITE	WHITE
	RED		BLUE		GREEN
	WHITE		WHITE		WHITE

RF CABLE COLOR CODES

NO SCALE

1

LOW BANDS (N71+N26)
OPTIONAL - (N29)



AWS
(N66+N70+H-BLOCK)



CBRS TECH
(3 GHz)



NEGATIVE SLANT PORT
ON ANT/RRH



ALPHA SECTOR



BETA SECTOR



GAMMA SECTOR



COLOR IDENTIFIER

NO SCALE

2

NOT USED

NO SCALE

3

NOT USED

NO SCALE

4



5701 SOUTH SANTA FE DRIVE
LITTLETON, CO 80120



B&T ENGINEERING, INC.

IT IS A VIOLATION OF LAW FOR ANY PERSON,
UNLESS THEY ARE ACTING UNDER THE DIRECTION
OF A LICENSED PROFESSIONAL ENGINEER,
TO ALTER THIS DOCUMENT.

DRAWN BY:	CHECKED BY:	APPROVED BY:
ANP	JCO	MDW

RFDS REV #: 1.0

PRELIMINARY DOCUMENTS

SUBMITTALS		
REV	DATE	DESCRIPTION
A	8/13/21	ISSUED FOR REVIEW
0	8/27/21	ISSUED FOR CONSTRUCTION

A&E PROJECT NUMBER
153984.001.01

DISH Wireless L.L.C.
PROJECT INFORMATION

MNDLH00051A
2810 FANTA REED RD
LA CROSSE, WI 54603

SHEET TITLE
RF
CABLE COLOR CODES

SHEET NUMBER

RF-1

EXOTHERMIC CONNECTION
 MECHANICAL CONNECTION
 BUSS BAR INSULATOR
 CHEMICAL ELECTROLYTIC GROUNDING SYSTEM
 TEST CHEMICAL ELECTROLYTIC GROUNDING SYSTEM
 EXOTHERMIC WITH INSPECTION SLEEVE
 GROUNDING BAR
 GROUND ROD
 TEST GROUND ROD WITH INSPECTION SLEEVE

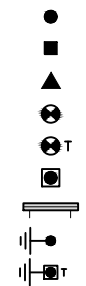

SINGLE POLE SWITCH
 DUPLEX RECEPTACLE
 DUPLEX GFCI RECEPTACLE
 FLUORESCENT LIGHTING FIXTURE (2) TWO LAMPS 48-T8

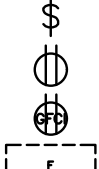

SMOKE DETECTION (DC)
 EMERGENCY LIGHTING (DC)
 SECURITY LIGHT W/PHOTOCELL LITHONIA ALXW LED-1-25A400/51K-SR4-120-PE-DOBTXD

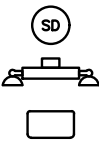

CHAIN LINK FENCE
 WOOD/WROUGHT IRON FENCE
 WALL STRUCTURE
 LEASE AREA
 PROPERTY LINE (PL)

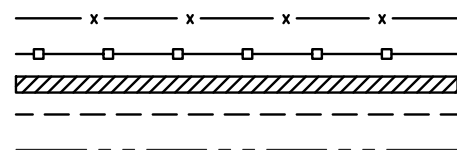

SETBACKS
 ICE BRIDGE
 CABLE TRAY
 WATER LINE

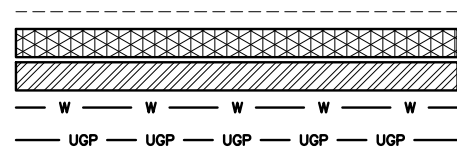

UNDERGROUND POWER
 UNDERGROUND TELCO
 OVERHEAD POWER
 OVERHEAD TELCO

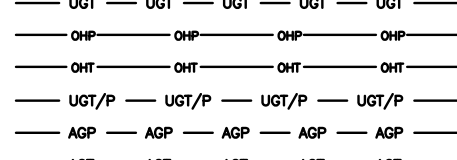

UNDERGROUND TELCO/POWER
 ABOVE GROUND POWER
 ABOVE GROUND TELCO
 ABOVE GROUND TELCO/POWER
 WORKPOINT

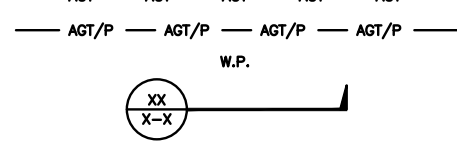

SECTION REFERENCE

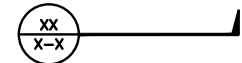

DETAIL REFERENCE



AB ANCHOR BOLT	IN INCH
ABV ABOVE	INT INTERIOR
AC ALTERNATING CURRENT	LB(S) POUND(S)
ADDL ADDITIONAL	LF LINEAR FEET
AFF ABOVE FINISHED FLOOR	LTE LONG TERM EVOLUTION
AFG ABOVE FINISHED GRADE	MAS MASONRY
AGL ABOVE GROUND LEVEL	MAX MAXIMUM
AIC AMPERAGE INTERRUPTION CAPACITY	MB MACHINE BOLT
ALUM ALUMINUM	MECH MECHANICAL
ALT ALTERNATE	MFR MANUFACTURER
ANT ANTENNA	MGB MASTER GROUND BAR
APPROX APPROXIMATE	MIN MINIMUM
ARCH ARCHITECTURAL	MISC MISCELLANEOUS
ATS AUTOMATIC TRANSFER SWITCH	MTL METAL
AWG AMERICAN WIRE GAUGE	MTS MANUAL TRANSFER SWITCH
BATT BATTERY	MW MICROWAVE
BLDG BUILDING	NEC NATIONAL ELECTRIC CODE
BLK BLOCK	NM NEWTON METERS
BLKG BLOCKING	NO. NUMBER
BM BEAM	# NUMBER
BTC BARE TINNED COPPER CONDUCTOR	NTS NOT TO SCALE
BOF BOTTOM OF FOOTING	OC ON-CENTER
CAB CABINET	OSHA OCCUPATIONAL SAFETY AND HEALTH ADMINISTRATION
CANT CANTILEVERED	OPNG OPENING
CHG CHARGING	P/C PRECAST CONCRETE
CLG CEILING	PCS PERSONAL COMMUNICATION SERVICES
CLR CLEAR	PCU PRIMARY CONTROL UNIT
COL COLUMN	PRC PRIMARY RADIO CABINET
COMM COMMON	PP POLARIZING PRESERVING
CONC CONCRETE	PSF POUNDS PER SQUARE FOOT
CONSTR CONSTRUCTION	PSI POUNDS PER SQUARE INCH
DBL DOUBLE	PT PRESSURE TREATED
DC DIRECT CURRENT	PWR POWER CABINET
DEPT DEPARTMENT	QTY QUANTITY
DF DOUGLAS FIR	RAD RADIUS
DIA DIAMETER	RECT RECTIFIER
DIAG DIAGONAL	REF REFERENCE
DIM DIMENSION	REINF REINFORCEMENT
DWG DRAWING	REQ'D REQUIRED
DWL DOWEL	RET REMOTE ELECTRIC TILT
EA EACH	RF RADIO FREQUENCY
EC ELECTRICAL CONDUCTOR	RMC RIGID METALLIC CONDUIT
EL ELEVATION	RRH REMOTE RADIO HEAD
ELEC ELECTRICAL	RRU REMOTE RADIO UNIT
EMT ELECTRICAL METALLIC TUBING	RWY RACEWAY
ENG ENGINEER	SCH SCHEDULE
EQ EQUAL	SHT SHEET
EXP EXPANSION	SIAD SMART INTEGRATED ACCESS DEVICE
EXT EXTERIOR	SIM SIMILAR
EW EACH WAY	SPEC SPECIFICATION
FAB FABRICATION	SQ SQUARE
FF FINISH FLOOR	SS STAINLESS STEEL
FG FINISH GRADE	STD STANDARD
FIF FACILITY INTERFACE FRAME	STL STEEL
FIN FINISH(ED)	TEMP TEMPORARY
FLR FLOOR	THK THICKNESS
FDN FOUNDATION	TMA TOWER MOUNTED AMPLIFIER
FOC FACE OF CONCRETE	TN TOE NAIL
FOM FACE OF MASONRY	TOA TOP OF ANTENNA
FOS FACE OF STUD	TOC TOP OF CURB
FOW FACE OF WALL	TOF TOP OF FOUNDATION
FS FINISH SURFACE	TOP TOP OF PLATE (PARAPET)
FT FOOT	TOS TOP OF STEEL
FTG FOOTING	TOW TOP OF WALL
GA GAUGE	TVSS TRANSIENT VOLTAGE SURGE SUPPRESSION
GEN GENERATOR	TYP TYPICAL
GFCI GROUND FAULT CIRCUIT INTERRUPTER	UG UNDERGROUND
GLB GLUE LAMINATED BEAM	UL UNDERWRITERS LABORATORY
GLV GALVANIZED	UNO UNLESS NOTED OTHERWISE
GPS GLOBAL POSITIONING SYSTEM	UMTS UNIVERSAL MOBILE TELECOMMUNICATIONS SYSTEM
GND GROUND	UPS UNINTERRUPTIBLE POWER SYSTEM (DC POWER PLANT)
GSM GLOBAL SYSTEM FOR MOBILE	VIF VERIFIED IN FIELD
HDG HOT DIPPED GALVANIZED	W WIDE
HDR HEADER	W/ WITH
HGR HANGER	WD WOOD
HVAC HEAT/VENTILATION/AIR CONDITIONING	WP WEATHERPROOF
HT HEIGHT	WT WEIGHT
IGR INTERIOR GROUND RING	

LEGEND

ABBREVIATIONS



5701 SOUTH SANTA FE DRIVE
 LITTLETON, CO 80120



B&T ENGINEERING, INC.

IT IS A VIOLATION OF LAW FOR ANY PERSON, UNLESS THEY ARE ACTING UNDER THE DIRECTION OF A LICENSED PROFESSIONAL ENGINEER, TO ALTER THIS DOCUMENT.

DRAWN BY:	CHECKED BY:	APPROVED BY:
ANP	JCO	MDW

RFDS REV #: 1.0

PRELIMINARY DOCUMENTS

SUBMITTALS		
REV	DATE	DESCRIPTION
A	8/13/21	ISSUED FOR REVIEW
0	8/27/21	ISSUED FOR CONSTRUCTION

A&E PROJECT NUMBER
 153984.001.01

DISH Wireless L.L.C.
 PROJECT INFORMATION
 MNDLH00051A
 2810 FANTA REED RD
 LA CROSSE, WI 54603

SHEET TITLE
 LEGEND AND ABBREVIATIONS

SHEET NUMBER
GN-1

SITE ACTIVITY REQUIREMENTS:

- NOTICE TO PROCEED – NO WORK SHALL COMMENCE PRIOR TO CONTRACTOR RECEIVING A WRITTEN NOTICE TO PROCEED (NTP) AND THE ISSUANCE OF A PURCHASE ORDER. PRIOR TO ACCESSING/ENTERING THE SITE YOU MUST CONTACT THE DISH Wireless L.L.C. AND TOWER OWNER NOC & THE DISH Wireless L.L.C. AND TOWER OWNER CONSTRUCTION MANAGER.
- "LOOK UP" – DISH Wireless L.L.C. AND TOWER OWNER SAFETY CLIMB REQUIREMENT:
THE INTEGRITY OF THE SAFETY CLIMB AND ALL COMPONENTS OF THE CLIMBING FACILITY SHALL BE CONSIDERED DURING ALL STAGES OF DESIGN, INSTALLATION, AND INSPECTION. TOWER MODIFICATION, MOUNT REINFORCEMENTS, AND/OR EQUIPMENT INSTALLATIONS SHALL NOT COMPROMISE THE INTEGRITY OR FUNCTIONAL USE OF THE SAFETY CLIMB OR ANY COMPONENTS OF THE CLIMBING FACILITY ON THE STRUCTURE. THIS SHALL INCLUDE, BUT NOT BE LIMITED TO: PINCHING OF THE WIRE ROPE, BENDING OF THE WIRE ROPE FROM ITS SUPPORTS, DIRECT CONTACT OR CLOSE PROXIMITY TO THE WIRE ROPE WHICH MAY CAUSE FRICTIONAL WEAR, IMPACT TO THE ANCHORAGE POINTS IN ANY WAY, OR TO IMPEDE/BLOCK ITS INTENDED USE. ANY COMPROMISED SAFETY CLIMB, INCLUDING EXISTING CONDITIONS MUST BE TAGGED OUT AND REPORTED TO YOUR DISH Wireless L.L.C. AND DISH Wireless L.L.C. AND TOWER OWNER POC OR CALL THE NOC TO GENERATE A SAFETY CLIMB MAINTENANCE AND CONTRACTOR NOTICE TICKET.
- PRIOR TO THE START OF CONSTRUCTION, ALL REQUIRED JURISDICTIONAL PERMITS SHALL BE OBTAINED. THIS INCLUDES, BUT IS NOT LIMITED TO, BUILDING, ELECTRICAL, MECHANICAL, FIRE, FLOOD ZONE, ENVIRONMENTAL, AND ZONING. AFTER ONSITE ACTIVITIES AND CONSTRUCTION ARE COMPLETED, ALL REQUIRED PERMITS SHALL BE SATISFIED AND CLOSED OUT ACCORDING TO LOCAL JURISDICTIONAL REQUIREMENTS.
- ALL CONSTRUCTION MEANS AND METHODS; INCLUDING BUT NOT LIMITED TO, ERECTION PLANS, RIGGING PLANS, CLIMBING PLANS, AND RESCUE PLANS SHALL BE THE RESPONSIBILITY OF THE GENERAL CONTRACTOR RESPONSIBLE FOR THE EXECUTION OF THE WORK CONTAINED HEREIN, AND SHALL MEET ANSI/ASSE A10.48 (LATEST EDITION); FEDERAL, STATE, AND LOCAL REGULATIONS; AND ANY APPLICABLE INDUSTRY CONSENSUS STANDARDS RELATED TO THE CONSTRUCTION ACTIVITIES BEING PERFORMED. ALL RIGGING PLANS SHALL ADHERE TO ANSI/ASSE A10.48 (LATEST EDITION) AND DISH Wireless L.L.C. AND TOWER OWNER STANDARDS, INCLUDING THE REQUIRED INVOLVEMENT OF A QUALIFIED ENGINEER FOR CLASS IV CONSTRUCTION, TO CERTIFY THE SUPPORTING STRUCTURE(S) IN ACCORDANCE WITH ANSI/TIA-322 (LATEST EDITION).
- ALL SITE WORK TO COMPLY WITH DISH Wireless L.L.C. AND TOWER OWNER INSTALLATION STANDARDS FOR CONSTRUCTION ACTIVITIES ON DISH Wireless L.L.C. AND TOWER OWNER TOWER SITE AND LATEST VERSION OF ANSI/TIA-1019-A-2012 "STANDARD FOR INSTALLATION, ALTERATION, AND MAINTENANCE OF ANTENNA SUPPORTING STRUCTURES AND ANTENNAS."
- IF THE SPECIFIED EQUIPMENT CAN NOT BE INSTALLED AS SHOWN ON THESE DRAWINGS, THE CONTRACTOR SHALL PROPOSE AN ALTERNATIVE INSTALLATION FOR APPROVAL BY DISH Wireless L.L.C. AND TOWER OWNER PRIOR TO PROCEEDING WITH ANY SUCH CHANGE OF INSTALLATION.
- ALL MATERIALS FURNISHED AND INSTALLED SHALL BE IN STRICT ACCORDANCE WITH ALL APPLICABLE CODES, REGULATIONS AND ORDINANCES. CONTRACTOR SHALL ISSUE ALL APPROPRIATE NOTICES AND COMPLY WITH ALL LAWS, ORDINANCES, RULES, REGULATIONS AND LAWFUL ORDERS OF ANY PUBLIC AUTHORITY REGARDING THE PERFORMANCE OF THE WORK. ALL WORK CARRIED OUT SHALL COMPLY WITH ALL APPLICABLE MUNICIPAL AND UTILITY COMPANY SPECIFICATIONS AND LOCAL JURISDICTIONAL CODES, ORDINANCES AND APPLICABLE REGULATIONS.
- THE CONTRACTOR SHALL INSTALL ALL EQUIPMENT AND MATERIALS IN ACCORDANCE WITH MANUFACTURER'S RECOMMENDATIONS UNLESS SPECIFICALLY STATED OTHERWISE.
- THE CONTRACTOR SHALL CONTACT UTILITY LOCATING SERVICES INCLUDING PRIVATE LOCATES SERVICES PRIOR TO THE START OF CONSTRUCTION.
- ALL EXISTING ACTIVE SEWER, WATER, GAS, ELECTRIC AND OTHER UTILITIES WHERE ENCOUNTERED IN THE WORK, SHALL BE PROTECTED AT ALL TIMES AND WHERE REQUIRED FOR THE PROPER EXECUTION OF THE WORK, SHALL BE RELOCATED AS DIRECTED BY CONTRACTOR. EXTREME CAUTION SHOULD BE USED BY THE CONTRACTOR WHEN EXCAVATING OR DRILLING PIERS AROUND OR NEAR UTILITIES. CONTRACTOR SHALL PROVIDE SAFETY TRAINING FOR THE WORKING CREW. THIS WILL INCLUDE BUT NOT BE LIMITED TO A) FALL PROTECTION B) CONFINED SPACE C) ELECTRICAL SAFETY D) TRENCHING AND EXCAVATION E) CONSTRUCTION SAFETY PROCEDURES.
- ALL SITE WORK SHALL BE AS INDICATED ON THE STAMPED CONSTRUCTION DRAWINGS AND DISH PROJECT SPECIFICATIONS, LATEST APPROVED REVISION.
- CONTRACTOR SHALL KEEP THE SITE FREE FROM ACCUMULATING WASTE MATERIAL, DEBRIS, AND TRASH AT THE COMPLETION OF THE WORK. IF NECESSARY, RUBBISH, STUMPS, DEBRIS, STICKS, STONES AND OTHER REFUSE SHALL BE REMOVED FROM THE SITE AND DISPOSED OF LEGALLY.
- ALL EXISTING INACTIVE SEWER, WATER, GAS, ELECTRIC AND OTHER UTILITIES, WHICH INTERFERE WITH THE EXECUTION OF THE WORK, SHALL BE REMOVED AND/OR CAPPED, PLUGGED OR OTHERWISE DISCONTINUED AT POINTS WHICH WILL NOT INTERFERE WITH THE EXECUTION OF THE WORK, SUBJECT TO THE APPROVAL OF DISH Wireless L.L.C. AND TOWER OWNER, AND/OR LOCAL UTILITIES.
- THE CONTRACTOR SHALL PROVIDE SITE SIGNAGE IN ACCORDANCE WITH THE TECHNICAL SPECIFICATION FOR SITE SIGNAGE REQUIRED BY LOCAL JURISDICTION AND SIGNAGE REQUIRED ON INDIVIDUAL PIECES OF EQUIPMENT, ROOMS, AND SHELTERS.
- THE SITE SHALL BE GRADED TO CAUSE SURFACE WATER TO FLOW AWAY FROM THE CARRIER'S EQUIPMENT AND TOWER AREAS.
- THE SUB GRADE SHALL BE COMPACTED AND BROUGHT TO A SMOOTH UNIFORM GRADE PRIOR TO FINISHED SURFACE APPLICATION.
- THE AREAS OF THE OWNERS PROPERTY DISTURBED BY THE WORK AND NOT COVERED BY THE TOWER, EQUIPMENT OR DRIVEWAY, SHALL BE GRADED TO A UNIFORM SLOPE, AND STABILIZED TO PREVENT EROSION AS SPECIFIED ON THE CONSTRUCTION DRAWINGS AND/OR PROJECT SPECIFICATIONS.
- CONTRACTOR SHALL MINIMIZE DISTURBANCE TO EXISTING SITE DURING CONSTRUCTION. EROSION CONTROL MEASURES, IF REQUIRED DURING CONSTRUCTION, SHALL BE IN CONFORMANCE WITH THE LOCAL GUIDELINES FOR EROSION AND SEDIMENT CONTROL.
- THE CONTRACTOR SHALL PROTECT EXISTING IMPROVEMENTS, PAVEMENTS, CURBS, LANDSCAPING AND STRUCTURES. ANY DAMAGED PART SHALL BE REPAIRED AT CONTRACTOR'S EXPENSE TO THE SATISFACTION OF OWNER.
- CONTRACTOR SHALL LEGALLY AND PROPERLY DISPOSE OF ALL SCRAP MATERIALS SUCH AS COAXIAL CABLES AND OTHER ITEMS REMOVED FROM THE EXISTING FACILITY. ANTENNAS AND RADIOS REMOVED SHALL BE RETURNED TO THE OWNER'S DESIGNATED LOCATION.
- CONTRACTOR SHALL LEAVE PREMISES IN CLEAN CONDITION. TRASH AND DEBRIS SHOULD BE REMOVED FROM SITE ON A DAILY BASIS.
- NO FILL OR EMBANKMENT MATERIAL SHALL BE PLACED ON FROZEN GROUND. FROZEN MATERIALS, SNOW OR ICE SHALL NOT BE PLACED IN ANY FILL OR EMBANKMENT.

GENERAL NOTES:

- FOR THE PURPOSE OF CONSTRUCTION DRAWING, THE FOLLOWING DEFINITIONS SHALL APPLY:
CONTRACTOR:GENERAL CONTRACTOR RESPONSIBLE FOR CONSTRUCTION
CARRIER:DISH Wireless L.L.C.
TOWER OWNER:TOWER OWNER
- THESE DRAWINGS HAVE BEEN PREPARED USING STANDARDS OF PROFESSIONAL CARE AND COMPLETENESS NORMALLY EXERCISED UNDER SIMILAR CIRCUMSTANCES BY REPUTABLE ENGINEERS IN THIS OR SIMILAR LOCALITIES. IT IS ASSUMED THAT THE WORK DEPICTED WILL BE PERFORMED BY AN EXPERIENCED CONTRACTOR AND/OR WORKPEOPLE WHO HAVE A WORKING KNOWLEDGE OF THE APPLICABLE CODE STANDARDS AND REQUIREMENTS AND OF INDUSTRY ACCEPTED STANDARD GOOD PRACTICE. AS NOT EVERY CONDITION OR ELEMENT IS (OR CAN BE) EXPLICITLY SHOWN ON THESE DRAWINGS, THE CONTRACTOR SHALL USE INDUSTRY ACCEPTED STANDARD GOOD PRACTICE FOR MISCELLANEOUS WORK NOT EXPLICITLY SHOWN.
- THESE DRAWINGS REPRESENT THE FINISHED STRUCTURE. THEY DO NOT INDICATE THE MEANS OR METHODS OF CONSTRUCTION. THE CONTRACTOR SHALL BE SOLELY RESPONSIBLE FOR THE CONSTRUCTION MEANS, METHODS, TECHNIQUES, SEQUENCES, AND PROCEDURES. THE CONTRACTOR SHALL PROVIDE ALL MEASURES NECESSARY FOR PROTECTION OF LIFE AND PROPERTY DURING CONSTRUCTION. SUCH MEASURES SHALL INCLUDE, BUT NOT BE LIMITED TO, BRACING, FORMWORK, SHORING, ETC. SITE VISITS BY THE ENGINEER OR HIS REPRESENTATIVE WILL NOT INCLUDE INSPECTION OF THESE ITEMS AND IS FOR STRUCTURAL OBSERVATION OF THE FINISHED STRUCTURE ONLY.
- NOTES AND DETAILS IN THE CONSTRUCTION DRAWINGS SHALL TAKE PRECEDENCE OVER GENERAL NOTES AND TYPICAL DETAILS. WHERE NO DETAILS ARE SHOWN, CONSTRUCTION SHALL CONFORM TO SIMILAR WORK ON THE PROJECT, AND/OR AS PROVIDED FOR IN THE CONTRACT DOCUMENTS. WHERE DISCREPANCIES OCCUR BETWEEN PLANS, DETAILS, GENERAL NOTES, AND SPECIFICATIONS, THE GREATER, MORE STRICT REQUIREMENTS, SHALL GOVERN. IF FURTHER CLARIFICATION IS REQUIRED CONTACT THE ENGINEER OF RECORD.
- SUBSTANTIAL EFFORT HAS BEEN MADE TO PROVIDE ACCURATE DIMENSIONS AND MEASUREMENTS ON THE DRAWINGS TO ASSIST IN THE FABRICATION AND/OR PLACEMENT OF CONSTRUCTION ELEMENTS BUT IT IS THE SOLE RESPONSIBILITY OF THE CONTRACTOR TO FIELD VERIFY THE DIMENSIONS, MEASUREMENTS, AND/OR CLEARANCES SHOWN IN THE CONSTRUCTION DRAWINGS PRIOR TO FABRICATION OR CUTTING OF ANY NEW OR EXISTING CONSTRUCTION ELEMENTS. IF IT IS DETERMINED THAT THERE ARE DISCREPANCIES AND/OR CONFLICTS WITH THE CONSTRUCTION DRAWINGS THE ENGINEER OF RECORD IS TO BE NOTIFIED AS SOON AS POSSIBLE.
- PRIOR TO THE SUBMISSION OF BIDS, THE BIDDING CONTRACTOR SHALL VISIT THE CELL SITE TO FAMILIARIZE WITH THE EXISTING CONDITIONS AND TO CONFIRM THAT THE WORK CAN BE ACCOMPLISHED AS SHOWN ON THE CONSTRUCTION DRAWINGS. ANY DISCREPANCY FOUND SHALL BE BROUGHT TO THE ATTENTION OF CARRIER POC AND TOWER OWNER.
- ALL MATERIALS FURNISHED AND INSTALLED SHALL BE IN STRICT ACCORDANCE WITH ALL APPLICABLE CODES, REGULATIONS AND ORDINANCES. CONTRACTOR SHALL ISSUE ALL APPROPRIATE NOTICES AND COMPLY WITH ALL LAWS, ORDINANCES, RULES, REGULATIONS AND LAWFUL ORDERS OF ANY PUBLIC AUTHORITY REGARDING THE PERFORMANCE OF THE WORK. ALL WORK CARRIED OUT SHALL COMPLY WITH ALL APPLICABLE MUNICIPAL AND UTILITY COMPANY SPECIFICATIONS AND LOCAL JURISDICTIONAL CODES, ORDINANCES AND APPLICABLE REGULATIONS.
- UNLESS NOTED OTHERWISE, THE WORK SHALL INCLUDE FURNISHING MATERIALS, EQUIPMENT, APPURTENANCES AND LABOR NECESSARY TO COMPLETE ALL INSTALLATIONS AS INDICATED ON THE DRAWINGS.
- THE CONTRACTOR SHALL INSTALL ALL EQUIPMENT AND MATERIALS IN ACCORDANCE WITH MANUFACTURER'S RECOMMENDATIONS UNLESS SPECIFICALLY STATED OTHERWISE.
- IF THE SPECIFIED EQUIPMENT CAN NOT BE INSTALLED AS SHOWN ON THESE DRAWINGS, THE CONTRACTOR SHALL PROPOSE AN ALTERNATIVE INSTALLATION FOR APPROVAL BY THE CARRIER AND TOWER OWNER PRIOR TO PROCEEDING WITH ANY SUCH CHANGE OF INSTALLATION.
- CONTRACTOR IS TO PERFORM A SITE INVESTIGATION, BEFORE SUBMITTING BIDS, TO DETERMINE THE BEST ROUTING OF ALL CONDUITS FOR POWER, AND TELCO AND FOR GROUNDING CABLES AS SHOWN IN THE POWER, TELCO, AND GROUNDING PLAN DRAWINGS.
- THE CONTRACTOR SHALL PROTECT EXISTING IMPROVEMENTS, PAVEMENTS, CURBS, LANDSCAPING AND STRUCTURES. ANY DAMAGED PART SHALL BE REPAIRED AT CONTRACTOR'S EXPENSE TO THE SATISFACTION OF DISH Wireless L.L.C. AND TOWER OWNER
- CONTRACTOR SHALL LEGALLY AND PROPERLY DISPOSE OF ALL SCRAP MATERIALS SUCH AS COAXIAL CABLES AND OTHER ITEMS REMOVED FROM THE EXISTING FACILITY. ANTENNAS REMOVED SHALL BE RETURNED TO THE OWNER'S DESIGNATED LOCATION.
- CONTRACTOR SHALL LEAVE PREMISES IN CLEAN CONDITION. TRASH AND DEBRIS SHOULD BE REMOVED FROM SITE ON A DAILY BASIS.



5701 SOUTH SANTA FE DRIVE
LITTLETON, CO 80120



B&T ENGINEERING, INC.

IT IS A VIOLATION OF LAW FOR ANY PERSON, UNLESS THEY ARE ACTING UNDER THE DIRECTION OF A LICENSED PROFESSIONAL ENGINEER, TO ALTER THIS DOCUMENT.

DRAWN BY:	CHECKED BY:	APPROVED BY:
ANP	JCO	MDW

RFDS REV #: 1.0

PRELIMINARY DOCUMENTS

SUBMITTALS		
REV	DATE	DESCRIPTION
A	8/13/21	ISSUED FOR REVIEW
0	8/27/21	ISSUED FOR CONSTRUCTION

A&E PROJECT NUMBER
153984.001.01

DISH Wireless L.L.C.
PROJECT INFORMATION

MNDLH00051A
2810 FANTA REED RD
LA CROSSE, WI 54603

SHEET TITLE
GENERAL NOTES

SHEET NUMBER
GN-2

CONCRETE, FOUNDATIONS, AND REINFORCING STEEL:

1. ALL CONCRETE WORK SHALL BE IN ACCORDANCE WITH THE ACI 301, ACI 318, ACI 336, ASTM A184, ASTM A185 AND THE DESIGN AND CONSTRUCTION SPECIFICATION FOR CAST-IN-PLACE CONCRETE.
2. UNLESS NOTED OTHERWISE, SOIL BEARING PRESSURE USED FOR DESIGN OF SLABS AND FOUNDATIONS IS ASSUMED TO BE 1000 psf.
3. ALL CONCRETE SHALL HAVE A MINIMUM COMPRESSIVE STRENGTH (f'c) OF 3000 psi AT 28 DAYS, UNLESS NOTED OTHERWISE. NO MORE THAN 90 MINUTES SHALL ELAPSE FROM BATCH TIME TO TIME OF PLACEMENT UNLESS APPROVED BY THE ENGINEER OF RECORD. TEMPERATURE OF CONCRETE SHALL NOT EXCEED 90°f AT TIME OF PLACEMENT.
4. CONCRETE EXPOSED TO FREEZE-THAW CYCLES SHALL CONTAIN AIR ENTRAINING ADMIXTURES. AMOUNT OF AIR ENTRAINMENT TO BE BASED ON SIZE OF AGGREGATE AND F3 CLASS EXPOSURE (VERY SEVERE). CEMENT USED TO BE TYPE II PORTLAND CEMENT WITH A MAXIMUM WATER-TO-CEMENT RATIO (W/C) OF 0.45.
5. ALL STEEL REINFORCING SHALL CONFORM TO ASTM A615. ALL WELDED WIRE FABRIC (WWF) SHALL CONFORM TO ASTM A185. ALL SPLICES SHALL BE CLASS "B" TENSION SPLICES, UNLESS NOTED OTHERWISE. ALL HOOKS SHALL BE STANDARD 90 DEGREE HOOKS, UNLESS NOTED OTHERWISE. YIELD STRENGTH (Fy) OF STANDARD DEFORMED BARS ARE AS FOLLOWS:
 - #4 BARS AND SMALLER 40 ksi
 - #5 BARS AND LARGER 60 ksi
6. THE FOLLOWING MINIMUM CONCRETE COVER SHALL BE PROVIDED FOR REINFORCING STEEL UNLESS SHOWN OTHERWISE ON DRAWINGS:
 - CONCRETE CAST AGAINST AND PERMANENTLY EXPOSED TO EARTH 3"
 - CONCRETE EXPOSED TO EARTH OR WEATHER:
 - #6 BARS AND LARGER 2"
 - #5 BARS AND SMALLER 1-1/2"
 - CONCRETE NOT EXPOSED TO EARTH OR WEATHER:
 - SLAB AND WALLS 3/4"
 - BEAMS AND COLUMNS 1-1/2"
7. A TOOLED EDGE OR A 3/4" CHAMFER SHALL BE PROVIDED AT ALL EXPOSED EDGES OF CONCRETE, UNLESS NOTED OTHERWISE, IN ACCORDANCE WITH ACI 301 SECTION 4.2.4.

ELECTRICAL INSTALLATION NOTES:

1. ALL ELECTRICAL WORK SHALL BE PERFORMED IN ACCORDANCE WITH THE PROJECT SPECIFICATIONS, NEC AND ALL APPLICABLE FEDERAL, STATE, AND LOCAL CODES/ORDINANCES.
2. CONDUIT ROUTINGS ARE SCHEMATIC. CONTRACTOR SHALL INSTALL CONDUITS SO THAT ACCESS TO EQUIPMENT IS NOT BLOCKED AND TRIP HAZARDS ARE ELIMINATED.
3. WIRING, RACEWAY AND SUPPORT METHODS AND MATERIALS SHALL COMPLY WITH THE REQUIREMENTS OF THE NEC.
4. ALL CIRCUITS SHALL BE SEGREGATED AND MAINTAIN MINIMUM CABLE SEPARATION AS REQUIRED BY THE NEC.
- 4.1. ALL EQUIPMENT SHALL BEAR THE UNDERWRITERS LABORATORIES LABEL OF APPROVAL, AND SHALL CONFORM TO REQUIREMENT OF THE NATIONAL ELECTRICAL CODE.
- 4.2. ALL OVERCURRENT DEVICES SHALL HAVE AN INTERRUPTING CURRENT RATING THAT SHALL BE GREATER THAN THE SHORT CIRCUIT CURRENT TO WHICH THEY ARE SUBJECTED, 22,000 AIC MINIMUM. VERIFY AVAILABLE SHORT CIRCUIT CURRENT DOES NOT EXCEED THE RATING OF ELECTRICAL EQUIPMENT IN ACCORDANCE WITH ARTICLE 110.24 NEC OR THE MOST CURRENT ADOPTED CODE PRE THE GOVERNING JURISDICTION.
5. EACH END OF EVERY POWER PHASE CONDUCTOR, GROUNDING CONDUCTOR, AND TELCO CONDUCTOR OR CABLE SHALL BE LABELED WITH COLOR-CODED INSULATION OR ELECTRICAL TAPE (3M BRAND, 1/2" PLASTIC ELECTRICAL TAPE WITH UV PROTECTION, OR EQUAL). THE IDENTIFICATION METHOD SHALL CONFORM WITH NEC AND OSHA.
6. ALL ELECTRICAL COMPONENTS SHALL BE CLEARLY LABELED WITH LAMICOID TAGS SHOWING THEIR RATED VOLTAGE, PHASE CONFIGURATION, WIRE CONFIGURATION, POWER OR AMPACITY RATING AND BRANCH CIRCUIT ID NUMBERS (i.e. PANEL BOARD AND CIRCUIT ID'S).
7. PANEL BOARDS (ID NUMBERS) SHALL BE CLEARLY LABELED WITH PLASTIC LABELS.
8. TIE WRAPS ARE NOT ALLOWED.
9. ALL POWER AND EQUIPMENT GROUND WIRING IN TUBING OR CONDUIT SHALL BE SINGLE COPPER CONDUCTOR (#14 OR LARGER) WITH TYPE THHW, THWN, THWN-2, XHHW, XHHW-2, THW, THW-2, RHW, OR RHW-2 INSULATION UNLESS OTHERWISE SPECIFIED.
10. SUPPLEMENTAL EQUIPMENT GROUND WIRING LOCATED INDOORS SHALL BE SINGLE COPPER CONDUCTOR (#6 OR LARGER) WITH TYPE THHW, THWN, THWN-2, XHHW, XHHW-2, THW, THW-2, RHW, OR RHW-2 INSULATION UNLESS OTHERWISE SPECIFIED.
11. POWER AND CONTROL WIRING IN FLEXIBLE CORD SHALL BE MULTI-CONDUCTOR, TYPE SOOW CORD (#14 OR LARGER) UNLESS OTHERWISE SPECIFIED.
12. POWER AND CONTROL WIRING FOR USE IN CABLE TRAY SHALL BE MULTI-CONDUCTOR, TYPE TC CABLE (#14 OR LARGER), WITH TYPE THHW, THWN, THWN-2, XHHW, XHHW-2, THW, THW-2, RHW, OR RHW-2 INSULATION UNLESS OTHERWISE SPECIFIED.
13. ALL POWER AND GROUNDING CONNECTIONS SHALL BE CRIMP-STYLE, COMPRESSION WIRE LUGS AND WIRE NUTS BY THOMAS AND BETTS (OR EQUAL). LUGS AND WIRE NUTS SHALL BE RATED FOR OPERATION NOT LESS THAN 75° C (90° C IF AVAILABLE).
14. RACEWAY AND CABLE TRAY SHALL BE LISTED OR LABELED FOR ELECTRICAL USE IN ACCORDANCE WITH NEMA, UL, ANSI/IEEE AND NEC.
15. ELECTRICAL METALLIC TUBING (EMT), INTERMEDIATE METAL CONDUIT (IMC), OR RIGID METAL CONDUIT (RMC) SHALL BE USED FOR EXPOSED INDOOR LOCATIONS.

16. ELECTRICAL METALLIC TUBING (EMT) OR METAL-CLAD CABLE (MC) SHALL BE USED FOR CONCEALED INDOOR LOCATIONS.
17. SCHEDULE 40 PVC UNDERGROUND ON STRAIGHTS AND SCHEDULE 80 PVC FOR ALL ELBOWS/90s AND ALL APPROVED ABOVE GRADE PVC CONDUIT.
18. LIQUID-TIGHT FLEXIBLE METALLIC CONDUIT (LIQUID-TITE FLEX) SHALL BE USED INDOORS AND OUTDOORS, WHERE VIBRATION OCCURS OR FLEXIBILITY IS NEEDED.
19. CONDUIT AND TUBING FITTINGS SHALL BE THREADED OR COMPRESSION-TYPE AND APPROVED FOR THE LOCATION USED. SET SCREW FITTINGS ARE NOT ACCEPTABLE.
20. CABINETS, BOXES AND WIRE WAYS SHALL BE LABELED FOR ELECTRICAL USE IN ACCORDANCE WITH NEMA, UL, ANSI/IEEE AND THE NEC.
21. WIREWAYS SHALL BE METAL WITH AN ENAMEL FINISH AND INCLUDE A HINGED COVER, DESIGNED TO SWING OPEN DOWNWARDS (WIREMOLD SPECMATE WIREWAY).
22. SLOTTED WIRING DUCT SHALL BE PVC AND INCLUDE COVER (PANDUIT TYPE E OR EQUAL).
23. CONDUITS SHALL BE FASTENED SECURELY IN PLACE WITH APPROVED NON-PERFORATED STRAPS AND HANGERS. EXPLOSIVE DEVICES (i.e. POWDER-ACTUATED) FOR ATTACHING HANGERS TO STRUCTURE WILL NOT BE PERMITTED. CLOSELY FOLLOW THE LINES OF THE STRUCTURE, MAINTAIN CLOSE PROXIMITY TO THE STRUCTURE AND KEEP CONDUITS IN TIGHT ENVELOPES. CHANGES IN DIRECTION TO ROUTE AROUND OBSTACLES SHALL BE MADE WITH CONDUIT OUTLET BODIES. CONDUIT SHALL BE INSTALLED IN A NEAT AND WORKMANLIKE MANNER. PARALLEL AND PERPENDICULAR TO STRUCTURE WALL AND CEILING LINES. ALL CONDUIT SHALL BE FISHED TO CLEAR OBSTRUCTIONS. ENDS OF CONDUITS SHALL BE TEMPORARILY CAPPED FLUSH TO FINISH GRADE TO PREVENT CONCRETE, PLASTER OR DIRT FROM ENTERING. CONDUITS SHALL BE RIGIDLY CLAMPED TO BOXES BY GALVANIZED MALLEABLE IRON BUSHING ON INSIDE AND GALVANIZED MALLEABLE IRON LOCKNUT ON OUTSIDE AND INSIDE.
24. EQUIPMENT CABINETS, TERMINAL BOXES, JUNCTION BOXES AND PULL BOXES SHALL BE GALVANIZED OR EPOXY-COATED SHEET STEEL SHALL MEET OR EXCEED UL 50 AND BE RATED NEMA 1 (OR BETTER) FOR INTERIOR LOCATIONS AND NEMA 3 (OR BETTER) FOR EXTERIOR LOCATIONS.
25. METAL RECEPTACLE, SWITCH AND DEVICE BOXES SHALL BE GALVANIZED, EPOXY-COATED OR NON-CORRODING; SHALL MEET OR EXCEED UL 514A AND NEMA OS 1 AND BE RATED NEMA 1 (OR BETTER) FOR INTERIOR LOCATIONS AND WEATHER PROTECTED (WP OR BETTER) FOR EXTERIOR LOCATIONS.
26. NONMETALLIC RECEPTACLE, SWITCH AND DEVICE BOXES SHALL MEET OR EXCEED NEMA OS 2 (NEWEST REVISION) AND BE RATED NEMA 1 (OR BETTER) FOR INTERIOR LOCATIONS AND WEATHER PROTECTED (WP OR BETTER) FOR EXTERIOR LOCATIONS.
27. THE CONTRACTOR SHALL NOTIFY AND OBTAIN NECESSARY AUTHORIZATION FROM THE CARRIER AND/OR DISH Wireless L.L.C. AND TOWER OWNER BEFORE COMMENCING WORK ON THE AC POWER DISTRIBUTION PANELS.
28. THE CONTRACTOR SHALL PROVIDE NECESSARY TAGGING ON THE BREAKERS, CABLES AND DISTRIBUTION PANELS IN ACCORDANCE WITH THE APPLICABLE CODES AND STANDARDS TO SAFEGUARD LIFE AND PROPERTY.
29. INSTALL LAMICOID LABEL ON THE METER CENTER TO SHOW "DISH Wireless L.L.C.".
30. ALL EMPTY/SPARE CONDUITS THAT ARE INSTALLED ARE TO HAVE A METERED MULE TAPE PULL CORD INSTALLED.



5701 SOUTH SANTA FE DRIVE
LITTLETON, CO 80120



B&T ENGINEERING, INC.

IT IS A VIOLATION OF LAW FOR ANY PERSON, UNLESS THEY ARE ACTING UNDER THE DIRECTION OF A LICENSED PROFESSIONAL ENGINEER, TO ALTER THIS DOCUMENT.

DRAWN BY:	CHECKED BY:	APPROVED BY:
ANP	JCO	MDW

RFDS REV #: 1.0

PRELIMINARY DOCUMENTS

SUBMITTALS		
REV	DATE	DESCRIPTION
A	8/13/21	ISSUED FOR REVIEW
0	8/27/21	ISSUED FOR CONSTRUCTION

A&E PROJECT NUMBER
153984.001.01

DISH Wireless L.L.C.
PROJECT INFORMATION
MNDLH00051A
2810 FANTA REED RD
LA CROSSE, WI 54603

SHEET TITLE
GENERAL NOTES

SHEET NUMBER
GN-3

GROUNDING NOTES:

1. ALL GROUND ELECTRODE SYSTEMS (INCLUDING TELECOMMUNICATION, RADIO, LIGHTNING PROTECTION AND AC POWER GES'S) SHALL BE BONDED TOGETHER AT OR BELOW GRADE, BY TWO OR MORE COPPER BONDING CONDUCTORS IN ACCORDANCE WITH THE NEC.
2. THE CONTRACTOR SHALL PERFORM IEEE FALL-OF-POTENTIAL RESISTANCE TO EARTH TESTING (PER IEEE 1100 AND 81) FOR GROUND ELECTRODE SYSTEMS, THE CONTRACTOR SHALL FURNISH AND INSTALL SUPPLEMENTAL GROUND ELECTRODES AS NEEDED TO ACHIEVE A TEST RESULT OF 5 OHMS OR LESS.
3. THE CONTRACTOR IS RESPONSIBLE FOR PROPERLY SEQUENCING GROUNDING AND UNDERGROUND CONDUIT INSTALLATION AS TO PREVENT ANY LOSS OF CONTINUITY IN THE GROUNDING SYSTEM OR DAMAGE TO THE CONDUIT AND PROVIDE TESTING RESULTS.
4. METAL CONDUIT AND TRAY SHALL BE GROUNDED AND MADE ELECTRICALLY CONTINUOUS WITH LISTED BONDING FITTINGS OR BY BONDING ACROSS THE DISCONTINUITY WITH #6 COPPER WIRE UL APPROVED GROUNDING TYPE CONDUIT CLAMPS.
5. METAL RACEWAY SHALL NOT BE USED AS THE NEC REQUIRED EQUIPMENT GROUND CONDUCTOR. STRANDED COPPER CONDUCTORS WITH GREEN INSULATION, SIZED IN ACCORDANCE WITH THE NEC, SHALL BE FURNISHED AND INSTALLED WITH THE POWER CIRCUITS TO BTS EQUIPMENT.
6. EACH CABINET FRAME SHALL BE DIRECTLY CONNECTED TO THE MASTER GROUND BAR WITH GREEN INSULATED SUPPLEMENTAL EQUIPMENT GROUND WIRES, #6 STRANDED COPPER OR LARGER FOR INDOOR BTS; #2 BARE SOLID TINNED COPPER FOR OUTDOOR BTS.
7. CONNECTIONS TO THE GROUND BUS SHALL NOT BE DOUBLED UP OR STACKED BACK TO BACK CONNECTIONS ON OPPOSITE SIDE OF THE GROUND BUS ARE PERMITTED.
8. ALL EXTERIOR GROUND CONDUCTORS BETWEEN EQUIPMENT/GROUND BARS AND THE GROUND RING SHALL BE #2 SOLID TINNED COPPER UNLESS OTHERWISE INDICATED.
9. ALUMINUM CONDUCTOR OR COPPER CLAD STEEL CONDUCTOR SHALL NOT BE USED FOR GROUNDING CONNECTIONS.
10. USE OF 90° BENDS IN THE PROTECTION GROUNDING CONDUCTORS SHALL BE AVOIDED WHEN 45° BENDS CAN BE ADEQUATELY SUPPORTED.
11. EXOTHERMIC WELDS SHALL BE USED FOR ALL GROUNDING CONNECTIONS BELOW GRADE.
12. ALL GROUND CONNECTIONS ABOVE GRADE (INTERIOR AND EXTERIOR) SHALL BE FORMED USING HIGH PRESS CRIMPS.
13. COMPRESSION GROUND CONNECTIONS MAY BE REPLACED BY EXOTHERMIC WELD CONNECTIONS.
14. ICE BRIDGE BONDING CONDUCTORS SHALL BE EXOTHERMICALLY BONDED OR BOLTED TO THE BRIDGE AND THE TOWER GROUND BAR.
15. APPROVED ANTIOXIDANT COATINGS (i.e. CONDUCTIVE GEL OR PASTE) SHALL BE USED ON ALL COMPRESSION AND BOLTED GROUND CONNECTIONS.
16. ALL EXTERIOR GROUND CONNECTIONS SHALL BE COATED WITH A CORROSION RESISTANT MATERIAL.
17. MISCELLANEOUS ELECTRICAL AND NON-ELECTRICAL METAL BOXES, FRAMES AND SUPPORTS SHALL BE BONDED TO THE GROUND RING, IN ACCORDANCE WITH THE NEC.
18. BOND ALL METALLIC OBJECTS WITHIN 6 ft OF MAIN GROUND RING WITH (1) #2 BARE SOLID TINNED COPPER GROUND CONDUCTOR.
19. GROUND CONDUCTORS USED FOR THE FACILITY GROUNDING AND LIGHTNING PROTECTION SYSTEMS SHALL NOT BE ROUTED THROUGH METALLIC OBJECTS THAT FORM A RING AROUND THE CONDUCTOR, SUCH AS METALLIC CONDUITS, METAL SUPPORT CLIPS OR SLEEVES THROUGH WALLS OR FLOORS. WHEN IT IS REQUIRED TO BE HOUSED IN CONDUIT TO MEET CODE REQUIREMENTS OR LOCAL CONDITIONS, NON-METALLIC MATERIAL SUCH AS PVC CONDUIT SHALL BE USED. WHERE USE OF METAL CONDUIT IS UNAVOIDABLE (i.e., NONMETALLIC CONDUIT PROHIBITED BY LOCAL CODE) THE GROUND CONDUCTOR SHALL BE BONDED TO EACH END OF THE METAL CONDUIT.
20. ALL GROUNDS THAT TRANSITION FROM BELOW GRADE TO ABOVE GRADE MUST BE #2 BARE SOLID TINNED COPPER IN 3/4" NON-METALLIC, FLEXIBLE CONDUIT FROM 24" BELOW GRADE TO WITHIN 3" TO 6" OF CAD-WELD TERMINATION POINT. THE EXPOSED END OF THE CONDUIT MUST BE SEALED WITH SILICONE CAULK. (ADD TRANSITIONING GROUND STANDARD DETAIL AS WELL).
21. BUILDINGS WHERE THE MAIN GROUNDING CONDUCTORS ARE REQUIRED TO BE ROUTED TO GRADE, THE CONTRACTOR SHALL ROUTE TWO GROUNDING CONDUCTORS FROM THE ROOFTOP, TOWERS, AND WATER TOWERS GROUNDING RING, TO THE EXISTING GROUNDING SYSTEM, THE GROUNDING CONDUCTORS SHALL NOT BE SMALLER THAN 2/0 COPPER. ROOFTOP GROUNDING RING SHALL BE BONDED TO THE EXISTING GROUNDING SYSTEM, THE BUILDING STEEL COLUMNS, LIGHTNING PROTECTION SYSTEM, AND BUILDING MAIN WATER LINE (FERROUS OR NONFERROUS METAL PIPING ONLY). DO NOT ATTACH GROUNDING TO FIRE SPRINKLER SYSTEM PIPES.



5701 SOUTH SANTA FE DRIVE
LITTLETON, CO 80120



AMERICAN TOWER®
10 PRESIDENTIAL WAY
WOBBURN, MA 01801



1717 S. BOULDER
SUITE 300
TULSA, OK 74119
PH: (918) 587-4630
www.blgrp.com



B&T ENGINEERING, INC.

IT IS A VIOLATION OF LAW FOR ANY PERSON, UNLESS THEY ARE ACTING UNDER THE DIRECTION OF A LICENSED PROFESSIONAL ENGINEER, TO ALTER THIS DOCUMENT.

DRAWN BY:	CHECKED BY:	APPROVED BY:
ANP	JCO	MDW

RFDS REV #: 1.0

PRELIMINARY DOCUMENTS

SUBMITTALS		
REV	DATE	DESCRIPTION
A	8/13/21	ISSUED FOR REVIEW
0	8/27/21	ISSUED FOR CONSTRUCTION

A&E PROJECT NUMBER
153984.001.01

DISH Wireless L.L.C.
PROJECT INFORMATION

MNDLH00051A
2810 FANTA REED RD
LA CROSSE, WI 54603

SHEET TITLE
GENERAL NOTES

SHEET NUMBER
GN-4