

**HSR ASSOCIATES INC.**  
100 MILWAUKEE STREET  
LA CROSSE, WISCONSIN  
PHONE: 608.784.1830  
FAX: 608.782.5844  
www.hsrassociates.com

Consultant:  
**POB**  
Point of Beginning

Project Title: **WESTERN TECHNICAL COLLEGE  
ARC & WELCOME CENTER PHASE 2 REMODEL**

Project Location: **400 N. 7TH STREET  
LA CROSSE, WI 54601**

Sheet Title: **DEMOLITION PLAN**

HSR Project Number: **18047**

Project Date: **2/12/2019**

Drawn By: **AAS**

Key Plan:

Revisions:

Graphic Scale: **1" = 20'**

Last Update: **2/11/2019**

**C100**

**GENERAL NOTES:**

- CONTACT DIGGER'S HOTLINE 5 WORKING DAYS PRIOR TO THE START OF DEMOLITION/CONSTRUCTION.
- ALL DEMOLITION MATERIALS SHALL BE REMOVED FROM THE SITE AND DISPOSED OF IN A LEGAL MANNER EXCEPT FOR THOSE ITEMS NOTED TO BE SALVAGED, WHICH SHOULD BE TURNED OVER TO THE OWNER.
- INSTALL AND MAINTAIN ALL REQUIRED EROSION CONTROL MEASURES FOR PERIMETER PROTECTION PRIOR TO THE START OF DEMOLITION/CONSTRUCTION, IN ACCORDANCE WITH THE LOCAL AND STATE GOVERNING AUTHORITIES.
- ALL BIDDERS SHALL VISIT THE SITE AND REVIEW EXISTING CONDITIONS PRIOR TO SUBMITTING A BID.
- COORDINATE WITH THE OWNER AND LOCAL UTILITY COMPANIES TO LOCATE ANY EXISTING UTILITIES ON SITE PRIOR TO THE START OF WORK.
- ANY EXISTING UTILITIES NOT SHOWN ON THIS DOCUMENT WHICH NEED TO BE REMOVED, RELOCATED OR ADJUSTED SHALL BE THE RESPONSIBILITY OF THE SITE GRADING CONTRACTOR AND INCLUDED IN THE BASE BID CONTRACT.
- STRIP TOPSOIL WITHIN THE PROJECT LIMITS IN ACCORDANCE WITH THE PROJECT MANUAL SPECIFICATIONS.
- IF STRIPPED TOPSOIL IS STOCKPILED ON SITE, SILT FENCE SHALL BE INSTALLED AROUND THE BASE OF THE STOCKPILE TO PREVENT SEDIMENT TRANSPORT.
- PRIOR TO PERFORMING WORK WITHIN PUBLIC RIGHT OF WAYS, NOTIFY AND COORDINATE WORK WITH THE LOCAL MUNICIPALITY AND OBTAIN ALL REQUIRED PERMITS.
- MAINTAIN TRAFFIC CIRCULATION ON ALL PUBLIC STREETS.

**KEYNOTES:**

- |  |   |
|--|---|
| 1 SAWCUT EXISTING CONCRETE CURBING         | 19 MAINTAIN EXISTING BUILDING CURBING   |
| 2 REMOVE EXISTING CONCRETE CURBING         | 20 MAINTAIN EXISTING FENCE  |
| 3 SAWCUT EXISTING BITUMINOUS PAVEMENT      | 21 REMOVE EXISTING RETAINING WALL   |
| 4 SAWCUT EXISTING CONCRETE WALK            | 22 MAINTAIN EXISTING RETAINING WALL   |
| 5 MAINTAIN EXISTING CONCRETE WALK          | 23 MAINTAIN EXISTING LANDSCAPE AREA: TREES, SHRUBS, MULCH AND FILTER FABRIC- VERIFY WITH LANDSCAPE PLAN |
| 6 MAINTAIN EXISTING CONCRETE CURBING       | 24 REMOVE EXISTING LANDSCAPE AREA: SHRUBS, MULCH AND FILTER FABRIC                                      |
| 7 MAINTAIN EXISTING SIGN                   | 25 MAINTAIN EXISTING POWER/LIGHT POLE   |
| 8 REMOVE/SALVAGE EXISTING SIGN             | 26 REMOVE AND SALVAGE EXISTING POWER/LIGHT POLE   |
| 9 MAINTAIN EXISTING TREE/VEGETATION        | 27 MAINTAIN EXISTING TRANSFORMER BOX  |
| 10 CLEAR & GRUB EXISTING TREE/VEGETATION   | 28 MAINTAIN EXISTING ELECTRICAL LINE  |
| 11 MAINTAIN EXISTING STORM SEWER STRUCTURE | 29 MAINTAIN EXISTING FIBER OPTIC LINE   |
| 12 REMOVE EXISTING STORM SEWER STRUCTURE   | 30 MAINTAIN EXISTING GAS LINE   |
| 13 REMOVE AND SALVAGE EXISTING BIKE RACK   | 31 MAINTAIN EXISTING BRICK PAVERS   |
| 14 MAINTAIN EXISTING BENCH                 | 32 MAINTAIN EXISTING COMMUNICATION LINE   |
| 15 MAINTAIN EXISTING WATER PIPE            | 33 SALVAGE EXISTING ELECTRICAL SIGN AND REINSTALL (SEE ELECTRICAL PLAN)                                 |
| 16 MAINTAIN EXISTING STORM SEWER PIPE      |   |
| 17 REMOVE EXISTING STORM SEWER PIPE        |   |
| 18 MAINTAIN EXISTING CANOPY                |   |

**DEMOLITION HATCH PATTERNS:**

- |                             |  |
|-----------------------------|--|
| BITUMINOUS AND BASE REMOVAL |  |
| CONCRETE REMOVAL            |  |
| BRICK PAVER REMOVAL         |  |

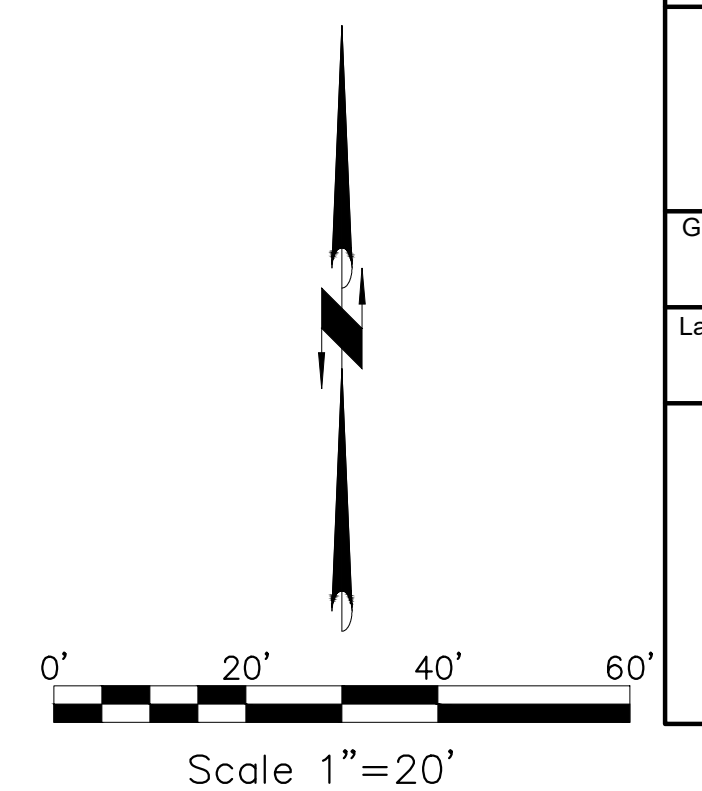
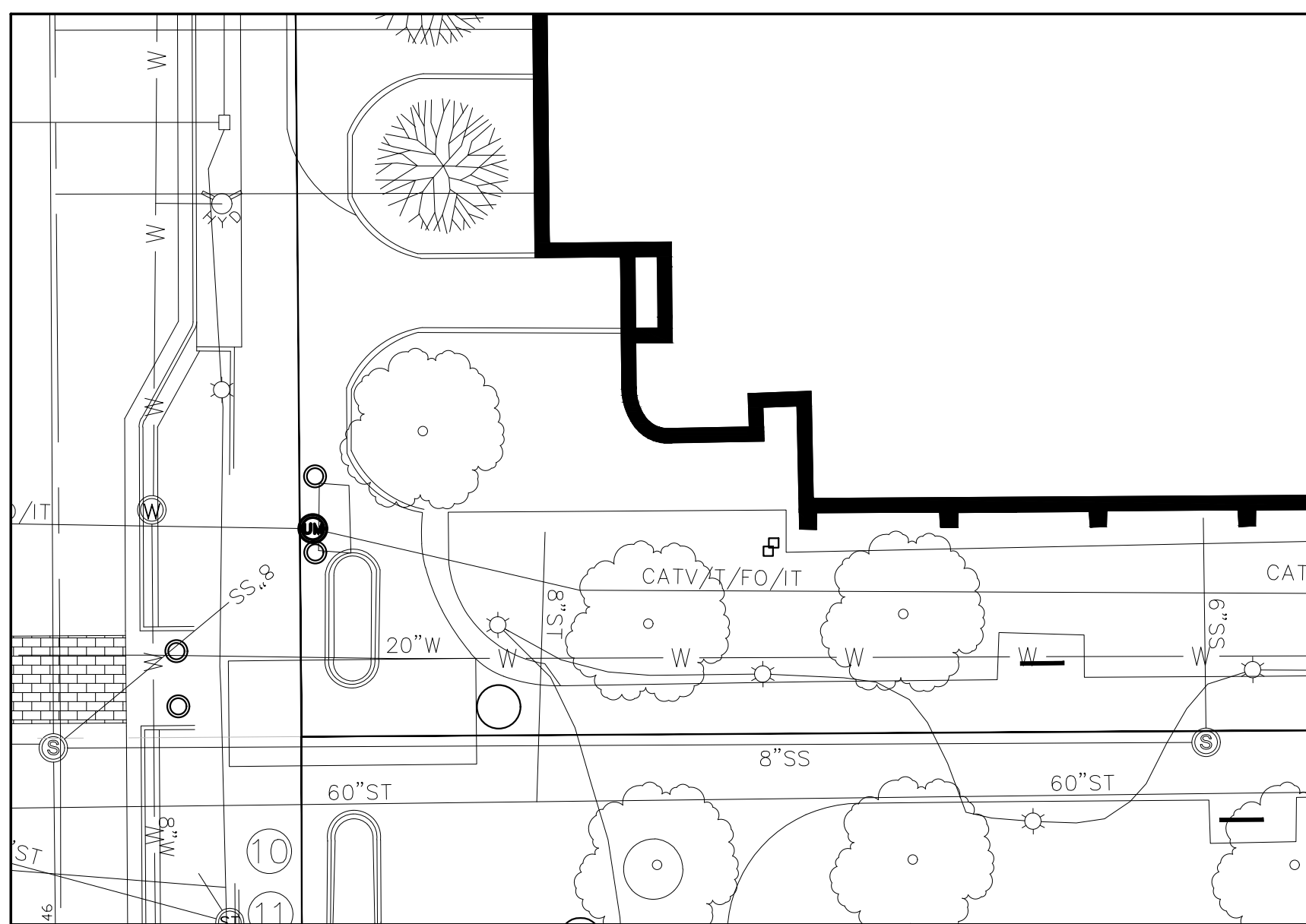
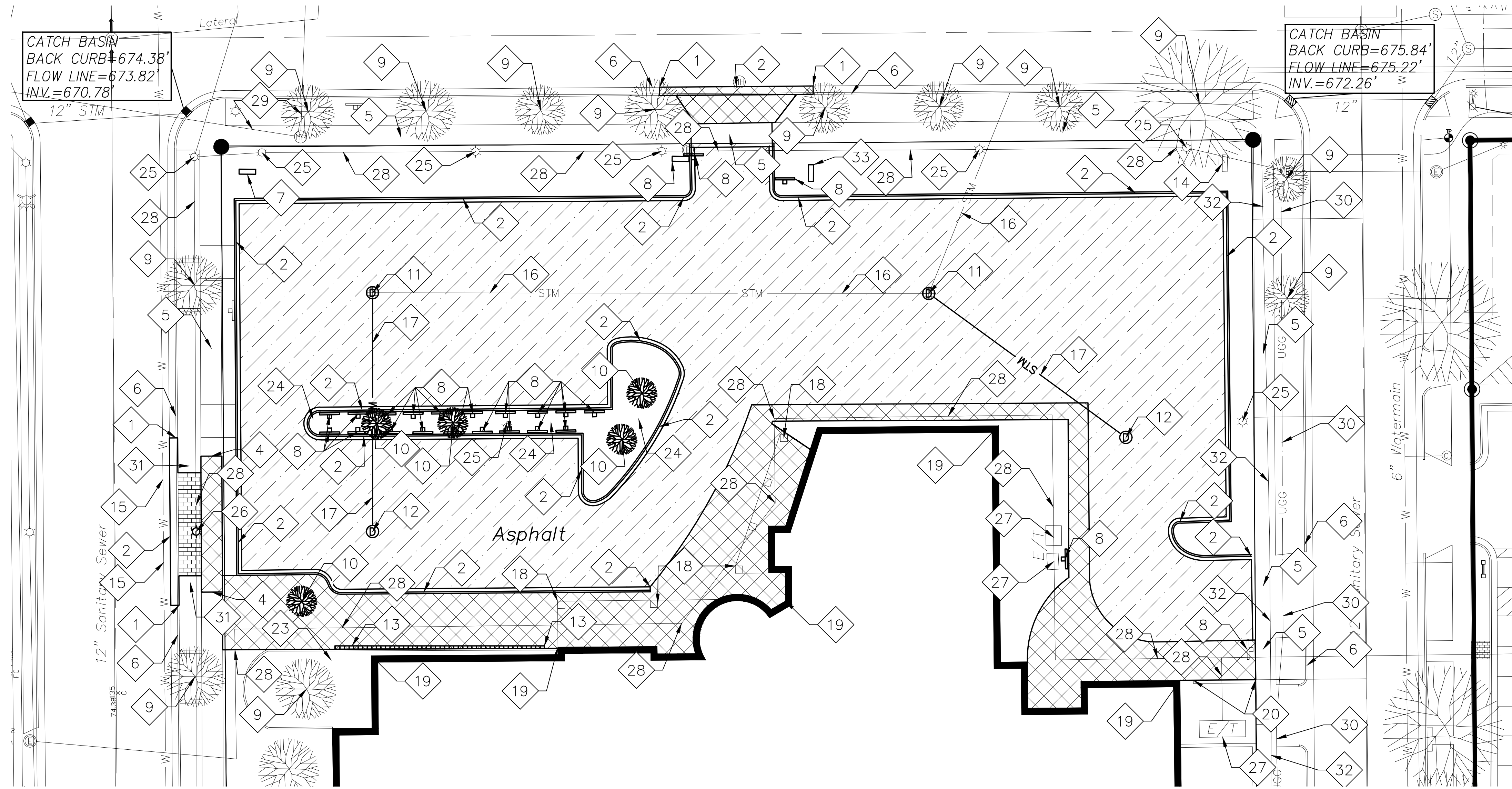

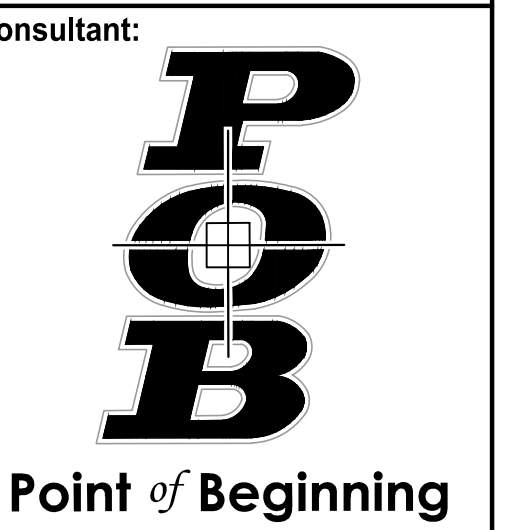
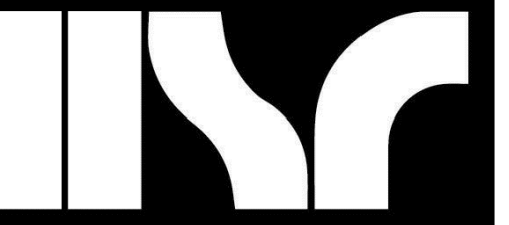

Revisions:

Revisions:

**GENERAL NOTES:**

- CONTACT DIGGER'S HOTLINE 5 WORKING DAYS PRIOR TO THE START OF DEMOLITION/CONSTRUCTION.
- GRADE, LINE, AND LEVEL TO BE REVIEWED IN THE FIELD BY THE CONSTRUCTION MANAGER.
- ALL REQUIRED EROSION CONTROL MEASURES ARE TO BE INSTALLED AND MAINTAINED IN ACCORDANCE WITH LOCAL MUNICIPAL AND DEPARTMENT OF NATURAL RESOURCES REGULATIONS.
- SEE SHEET C400 FOR ALL REQUIRED EROSION CONTROL ELEMENTS.
- ANY EXISTING UTILITIES NOT SHOWN ON THIS DOCUMENT WHICH NEED TO BE REMOVED, RELOCATED AND OR ADJUSTED SHALL BE THE RESPONSIBILITY OF THE SITE GRADING CONTRACTOR AND INCLUDED IN THE BASE BID CONTRACT.
- VERIFY THE LOCATION OF ALL EXISTING UTILITIES PRIOR TO THE START OF DEMOLITION/CONSTRUCTION.
- ALL BIDDERS SHALL VISIT THE SITE AND REVIEW EXISTING CONDITIONS PRIOR TO SUBMITTING A BID.
- PRIOR TO THE START OF WORK VERIFY WITH THE LOCAL AUTHORITIES THAT ALL REQUIRED PERMITS HAVE BEEN ACQUIRED.
- COORDINATE CONSTRUCTION IN THE RIGHT OF WAY WITH THE LOCAL AUTHORITIES.
- PROVIDE PROPER BARRICADES, SIGNS AND TRAFFIC CONTROL TO MAINTAIN THRU TRAFFIC ALONG ADJACENT STREETS IN ACCORDANCE WITH LOCAL MUNICIPAL REQUIREMENTS.
- SIDEWALK JOINTS TO BE AS INDICATED OR AS APPROVED BY CONSTRUCTION MANAGER.
- ALL SAWCUTS SHALL BE AT AN EXISTING JOINT IN THE CURB AND PAVEMENT.
- ALL GENERAL LANDSCAPE AREAS SHALL BE SEEDED/FERTILIZED/CRIMP HAY MULCHED IN ACCORDANCE WITH THE PROJECT SPECIFICATIONS.

**KEYNOTES:**

- |   |        |   |
|---|--------|---|
| ① 18" CONCRETE CURB & GUTTER                                  | ① C200 | ⑮ EXISTING LIGHT POLE TO REMAIN                               |
| ② 18" CONCRETE CURB & GUTTER (REJECT)                         | ① C200 | ⑯ EXISTING TREE TO REMAIN                                     |
| ③ 6" CURB TAPER SECTION                                       |        | ⑰ INSTALL VISITOR/ 1-HOUR PARKING SIGN                        |
| ④ STANDARD CURB TO REJECT CURB TRANSITION POINT               |        | ⑱ STOP SIGN   |
| ⑤ DRIVE APRON   | ② C200 | ⑲ ONE WAY SIGN  |
| ⑥ ADA CURB RAMP   | ⑤ C200 | ⑳ DO NOT ENTER SIGN   |
| ⑦ PARKING LOT STRIPING  | ① C300 | ㉑ DOWEL CURBING TO EXISTING WITH 2-#5 AT 18" EMBEDDED 6" TYP. |
| ⑧ DIRECTIONAL ARROW   | ① C300 | ㉒ EXISTING ELECTRICAL LINE TO REMAIN                          |
| ⑨ HANDICAP PARKING STALL                                      | ② C300 | ㉓ EXISTING GAS LINE TO REMAIN                                 |
| ⑩ HANDICAP PARKING SIGN                                       | ⑤ C300 | ㉔ EXISTING COMMUNICATION LINE TO REMAIN                       |
| ⑪ 8" PARKING STOP   |        | ㉕ INSTALL SALVAGED "WELCOME CENTER" SIGN                      |
| ⑫ INSTALL SALVAGED LIGHT POLE                                 |        | ㉖ DRIVE-OVER CURB & GUTTER                                    |
| ⑬ REINSTALL BIKE RACK-VERIFY FINAL LOCATION WITH OWNER        |        | ㉗ INSTALL MOTORCYCLE PARKING SIGN                             |
| ⑭ INSTALL SALVAGED "PARKING LOT C" SIGN (SEE ELECTRICAL PLAN) |        |   |

**PAVEMENT HATCH PATTERNS:**

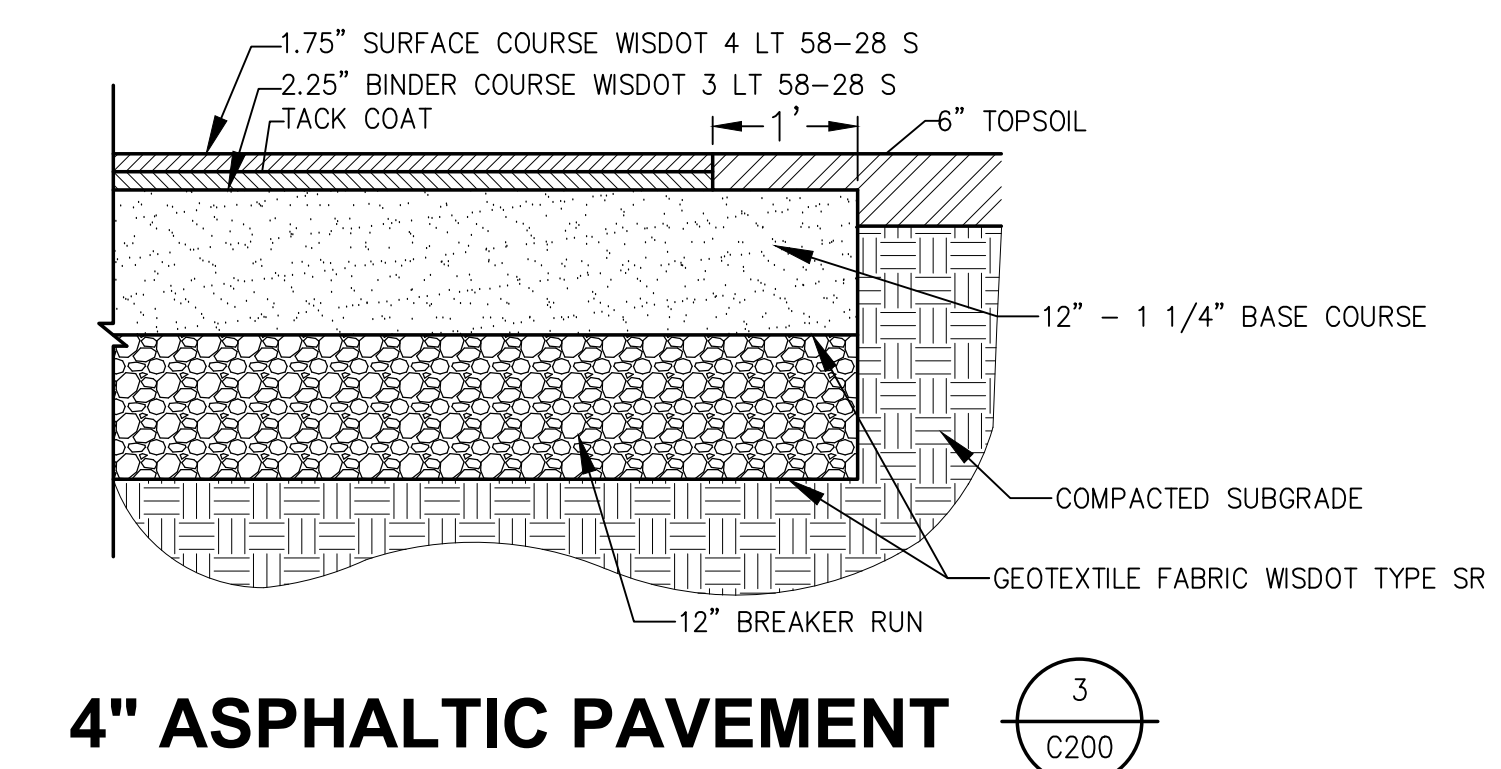
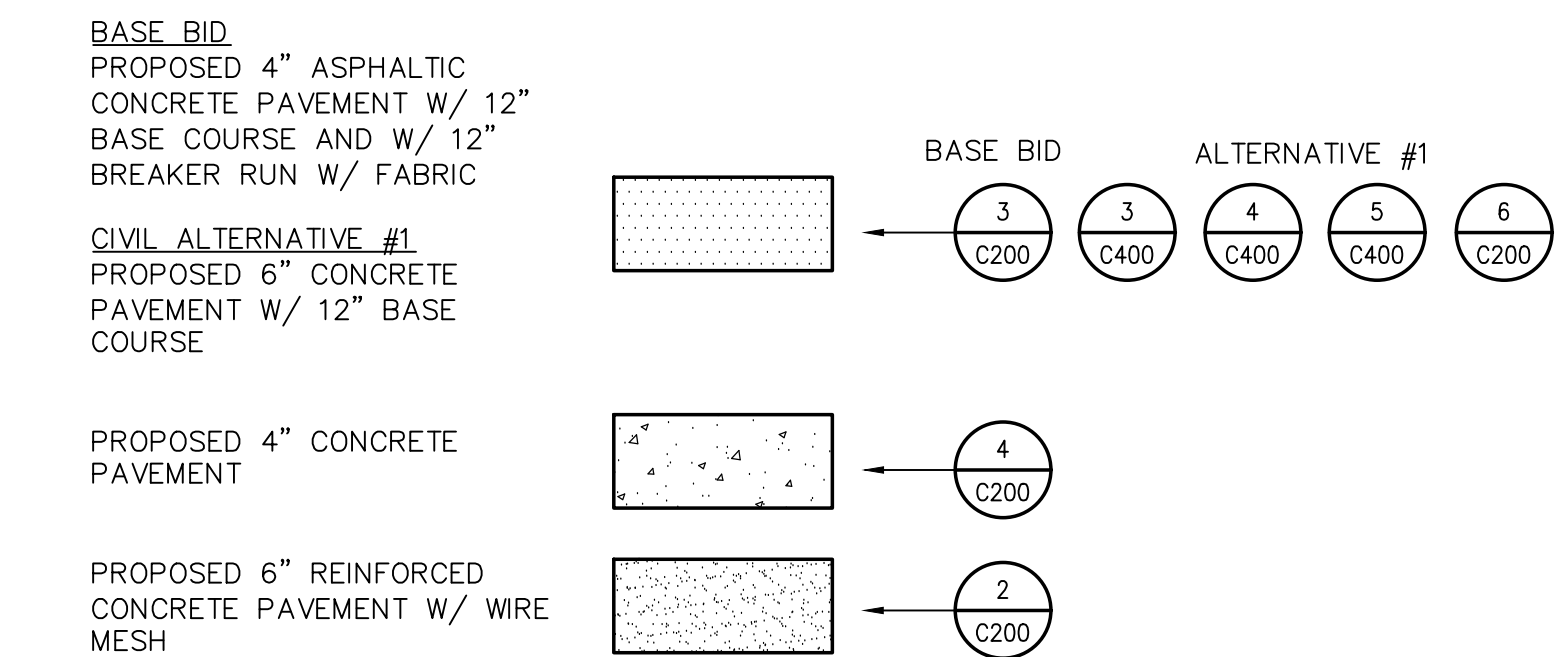

**6" CONCRETE PAVEMENT** ⑥ C200

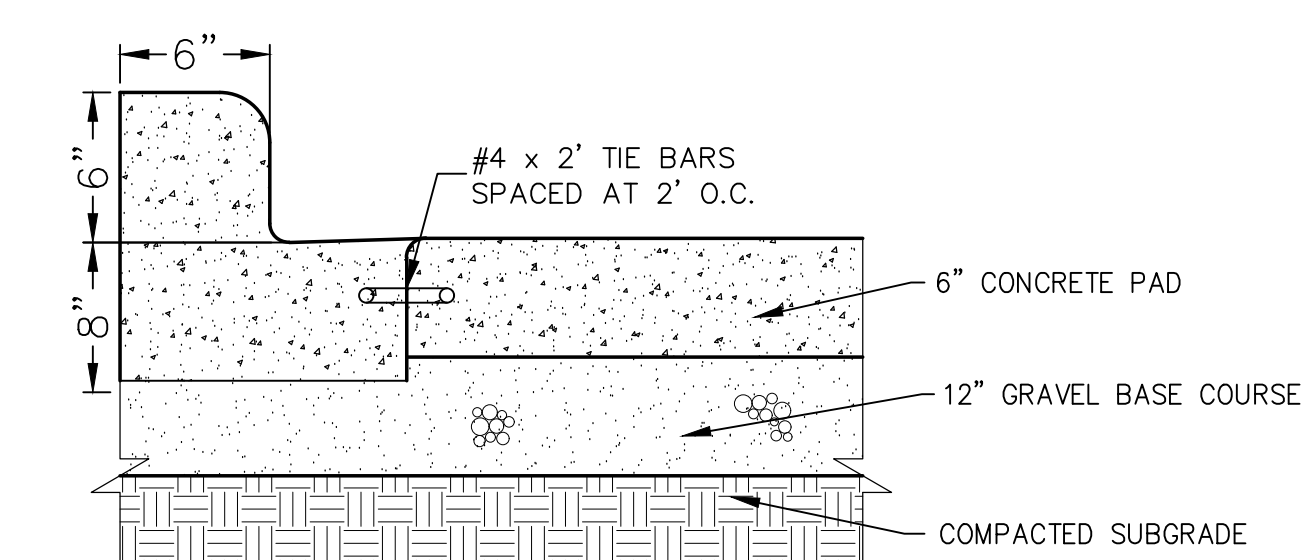

**4" ASPHALTIC PAVEMENT** ③ C200

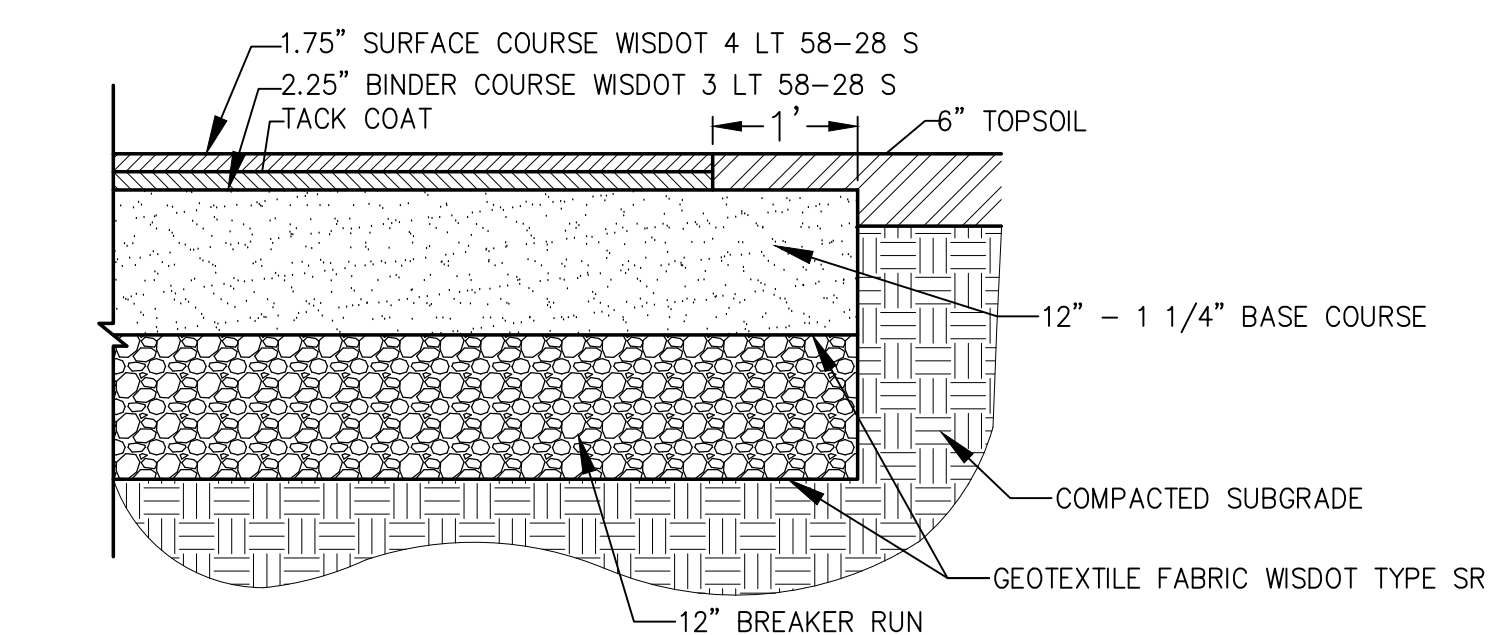

**REINFORCED CONCRETE** ② C200

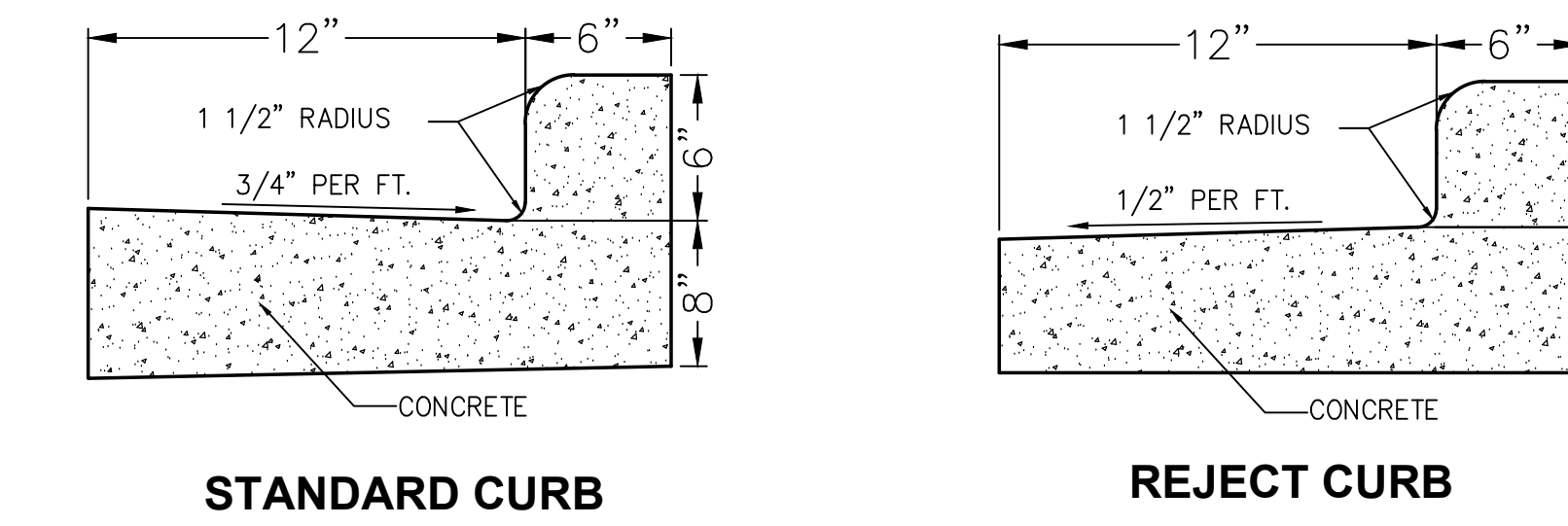

**CONCRETE CURB & GUTTER** ① C200

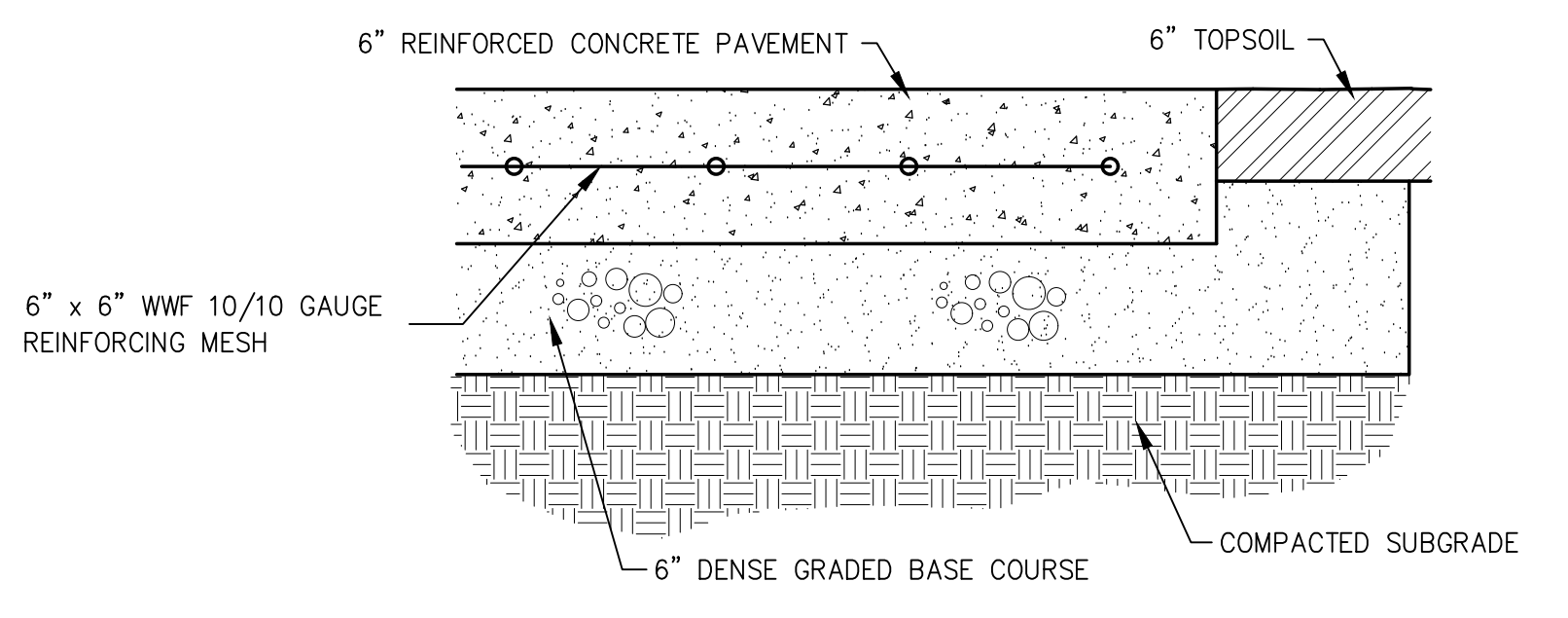

**REINFORCED CONCRETE** ② C200

**ADA CURB RAMP** ⑤ C200

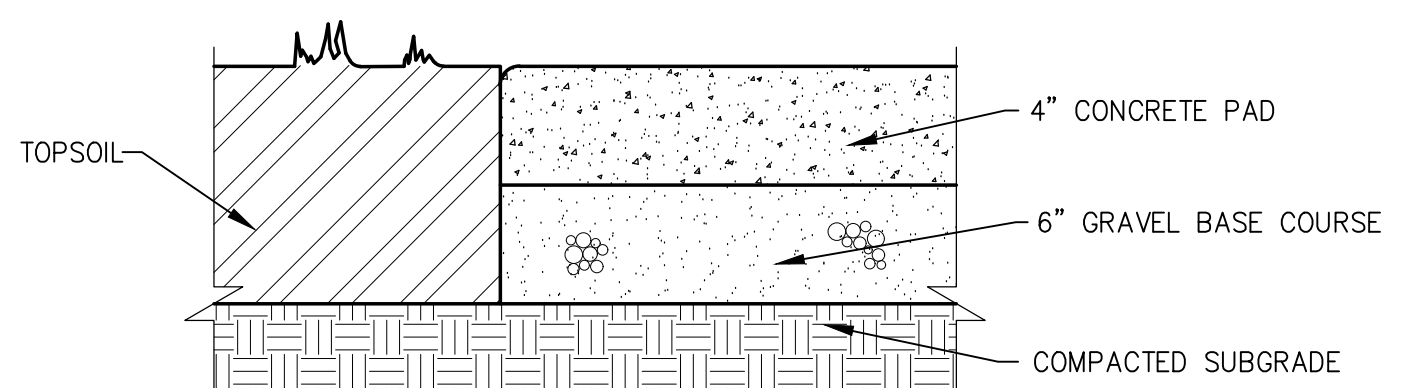
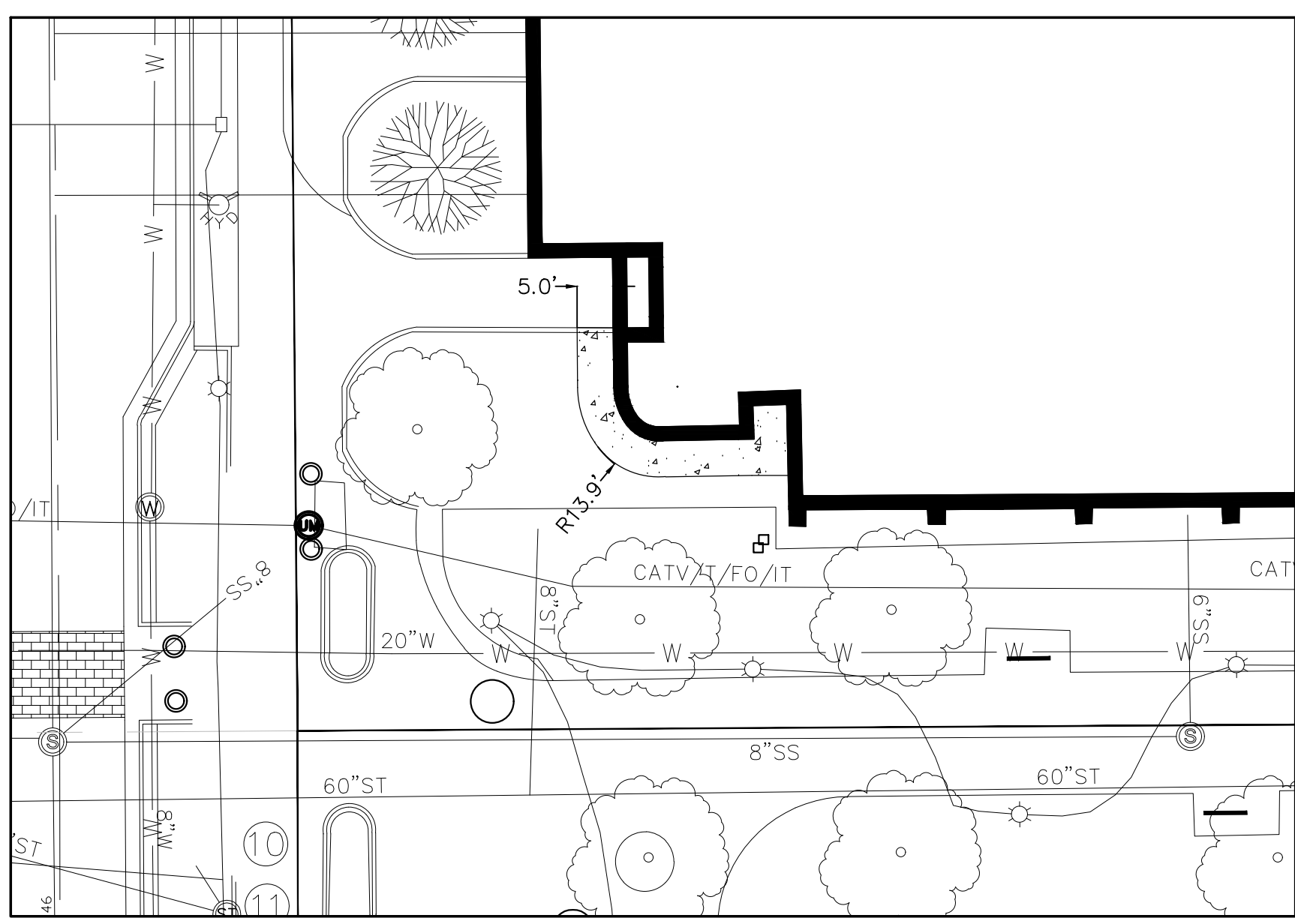
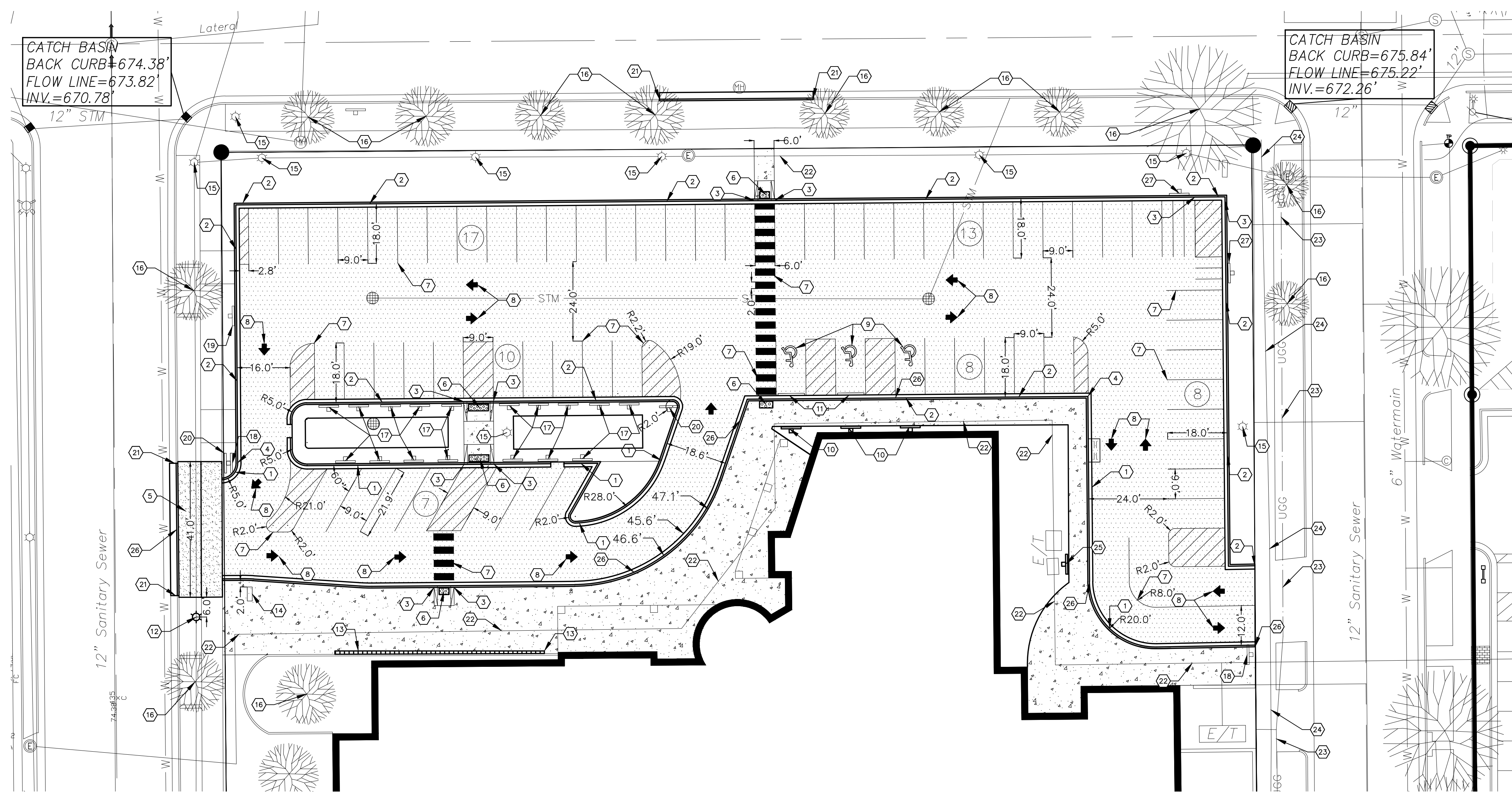
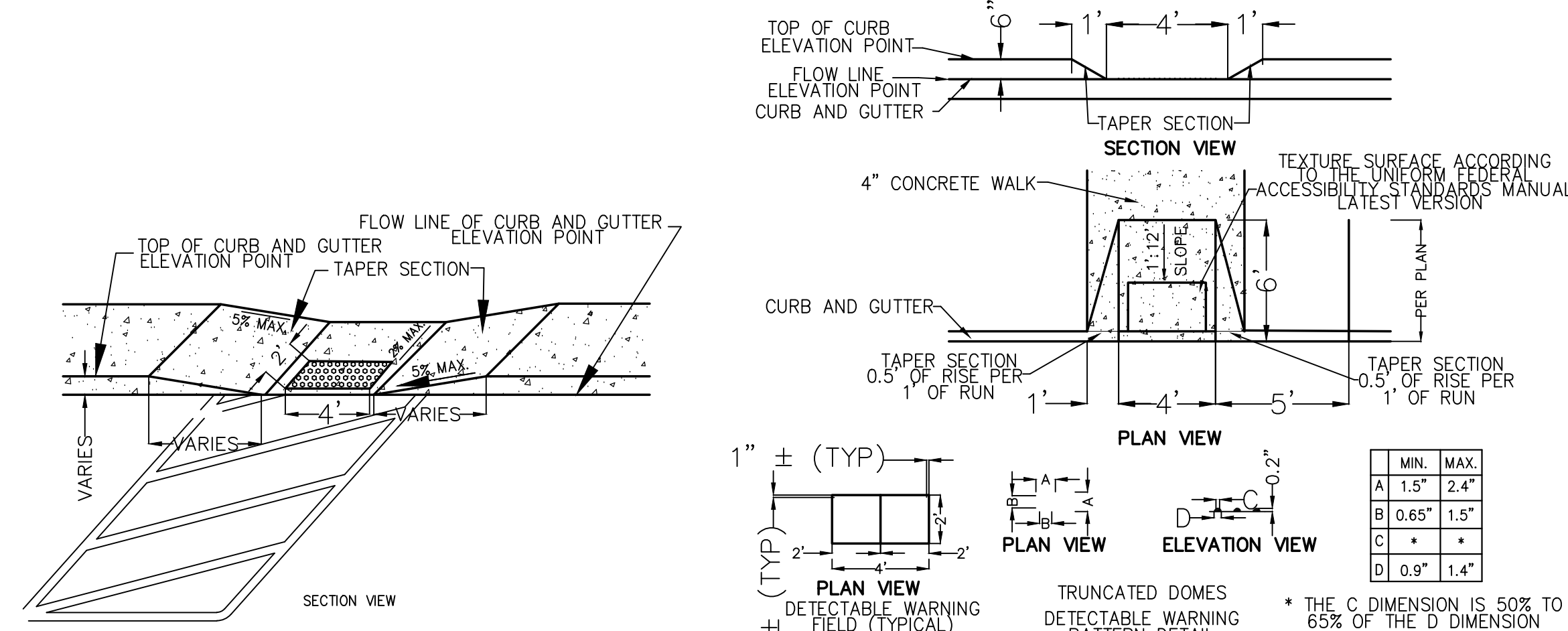

**4" CONCRETE PAVEMENT** ④ C200

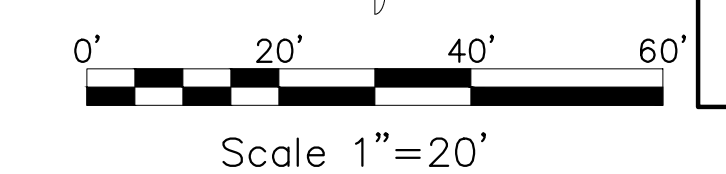

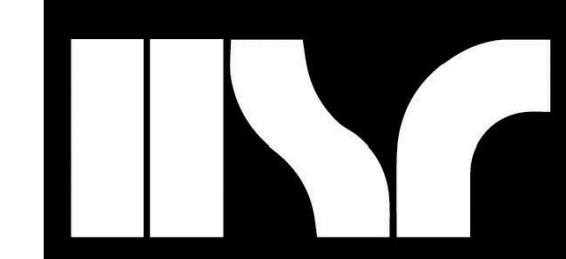

**HSR ASSOCIATES INC.**  
100 MILWAUKEE STREET  
LA CROSSE, WISCONSIN  
PHONE: 608.784.1830  
FAX: 608.782.5844  
www.hsrassociates.com

Consultant:  
**POB**  
Point of Beginning

WESTERN TECHNICAL COLLEGE  
ARC & WELCOME CENTER PHASE 2 REMODEL  
GRADING PLAN

Project Title:  
Project Location: 400 N. 7TH STREET  
LA CROSSE, WI 54601  
Sheet Title:

HSR Project Number: 18047  
Project Date: 2/12/2019  
Drawn By: AAS  
Key Plan:  
Revisions:  
Graphic Scale: 1" = 20'  
Last Update: 2/11/2019  
**C300**

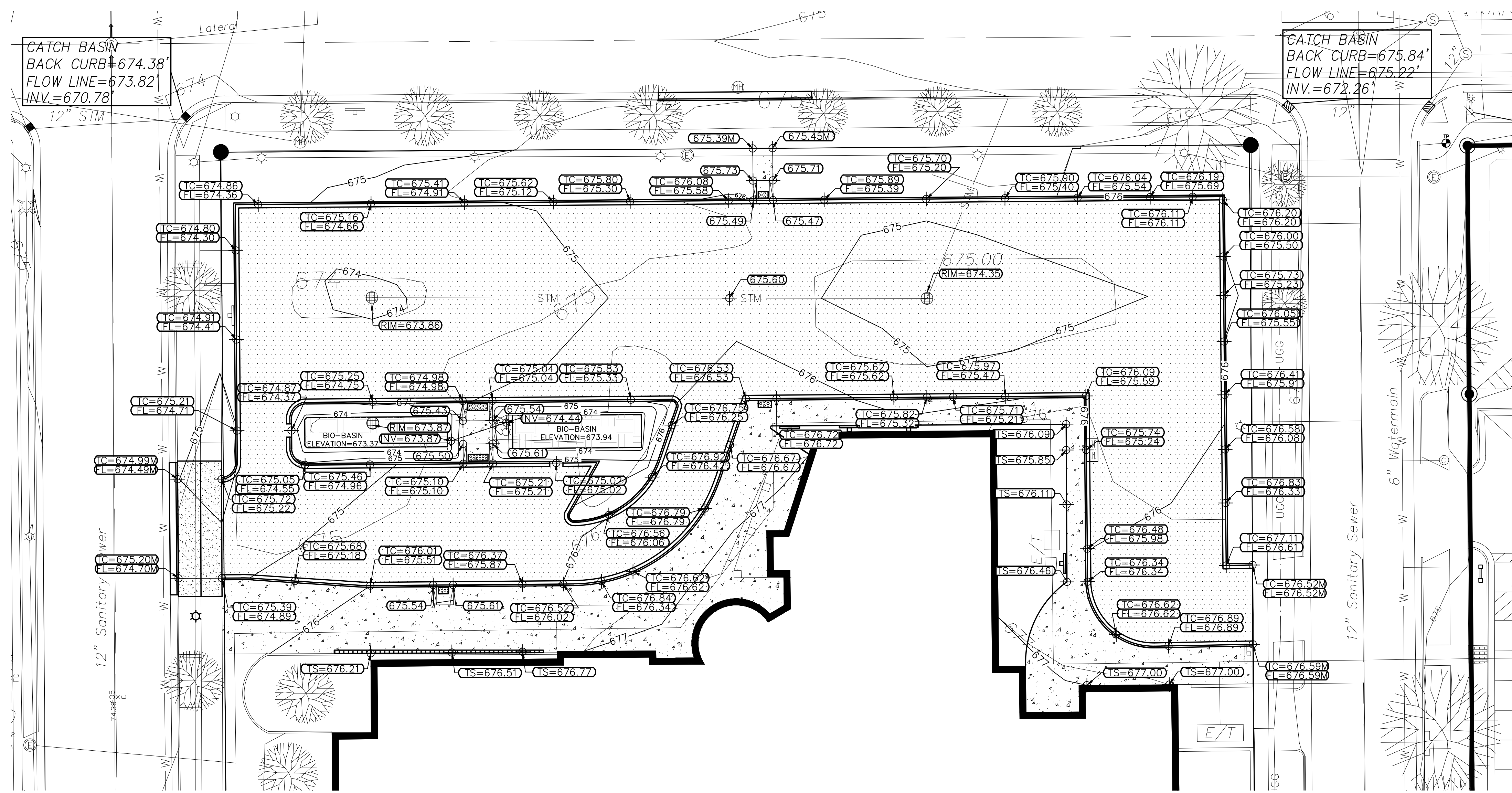

**GENERAL NOTES:**

- CONTACT DIGGER'S HOTLINE 5 WORKING DAYS PRIOR TO THE START OF DEMOLITION/CONSTRUCTION.
- GRADE, LINE, AND LEVEL TO BE REVIEWED IN THE FIELD BY THE CONSTRUCTION MANAGER.
- INSTALL AND MAINTAIN ALL REQUIRED EROSION CONTROL MEASURES IN ACCORDANCE WITH LOCAL AUTHORITIES AND THE DEPARTMENT OF NATURAL RESOURCES REGULATIONS.
- 6" OF TOPSOIL SHALL BE PROVIDED IN ALL GENERAL LAWN AREAS AND 12" SHALL BE PROVIDED IN ALL PLANTING BED AREAS.
- SEE SHEET C400 FOR ALL REQUIRED EROSION CONTROL ELEMENTS.
- ANY EXISTING UTILITIES NOT SHOWN ON THIS DOCUMENT WHICH NEED TO BE REMOVED, RELOCATED OR ADJUSTED SHALL BE THE RESPONSIBILITY OF THE SITE GRADING CONTRACTOR AND INCLUDED IN THE BASE BID CONTRACT.
- COORDINATE ALL EARTHWORK ACTIVITIES WITH THE RESPECTIVE TRADES RESPONSIBLE FOR THE INSTALLATION OF GAS, CABLE, TELEPHONE AND ELECTRICAL (INCLUDING MAIN SERVICE, SITE LIGHTING, CONDUITS AND SIGNAGE)
- PROVIDE RIP RAP AT PROPOSED CULVERT ENDWALL STRUCTURES TO PREVENT WASHOUT AND EROSION.
- RIP RAP SHALL HAVE WISDOT TYPE HR FILTER FABRIC PLACED BENEATH.
- EXCESS TOPSOIL SHALL BE REMOVED FROM SITE, UNLESS OTHERWISE DIRECTED BY THE OWNER. COORDINATE WITH OWNER FOR LOCATION OF STOCKPILE IF THE OWNER CHOOSES TO SALVAGE EXCESS TOPSOIL FOR FUTURE USE. SILT FENCE SHALL BE PLACED AROUND STOCKPILE.
- THE ENGINEERED SOIL SHALL NOT BE PLACED IN THE BIORETENTION AREAS UNTIL THE SURROUNDING DRAINAGE AREA HAS BEEN FULLY STABILIZED. ALL CONSTRUCTION SITE SEDIMENT SHALL BE REMOVED FROM THE SUBGRADE OF THE BIORETENTION AREA PRIOR TO PLACEMENT OF THE ENGINEERED SOIL.
- TESTING AND INSPECTION SHALL BE DONE IN ACCORDANCE WITH SPS 382.21.
- THE LOCAL MUNICIPALITY SHALL BE CONTACTED PRIOR TO ANY EXCAVATION IN THE PUBLIC RIGHT-OF-WAY. THE LOCAL MUNICIPALITY SHALL OPERATE ALL EXISTING WATER VALVES IF NEEDED.
- GRADES AT BUILDING EDGE SHALL BE 6" BELOW FINISHED FLOOR ELEVATION EXCEPT AT DOOR WAY ENTRANCES OR UNLESS OTHERWISE NOTED.

**GRADING LEGEND:**

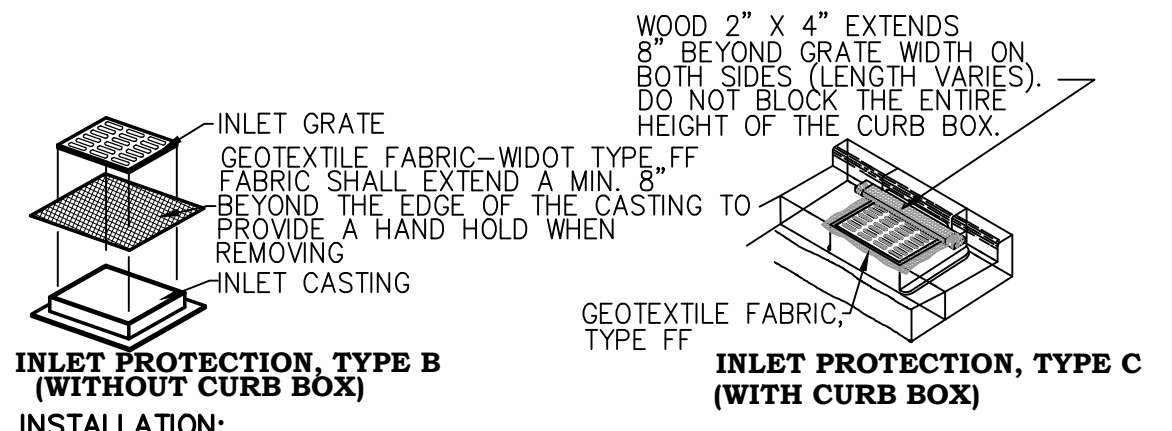
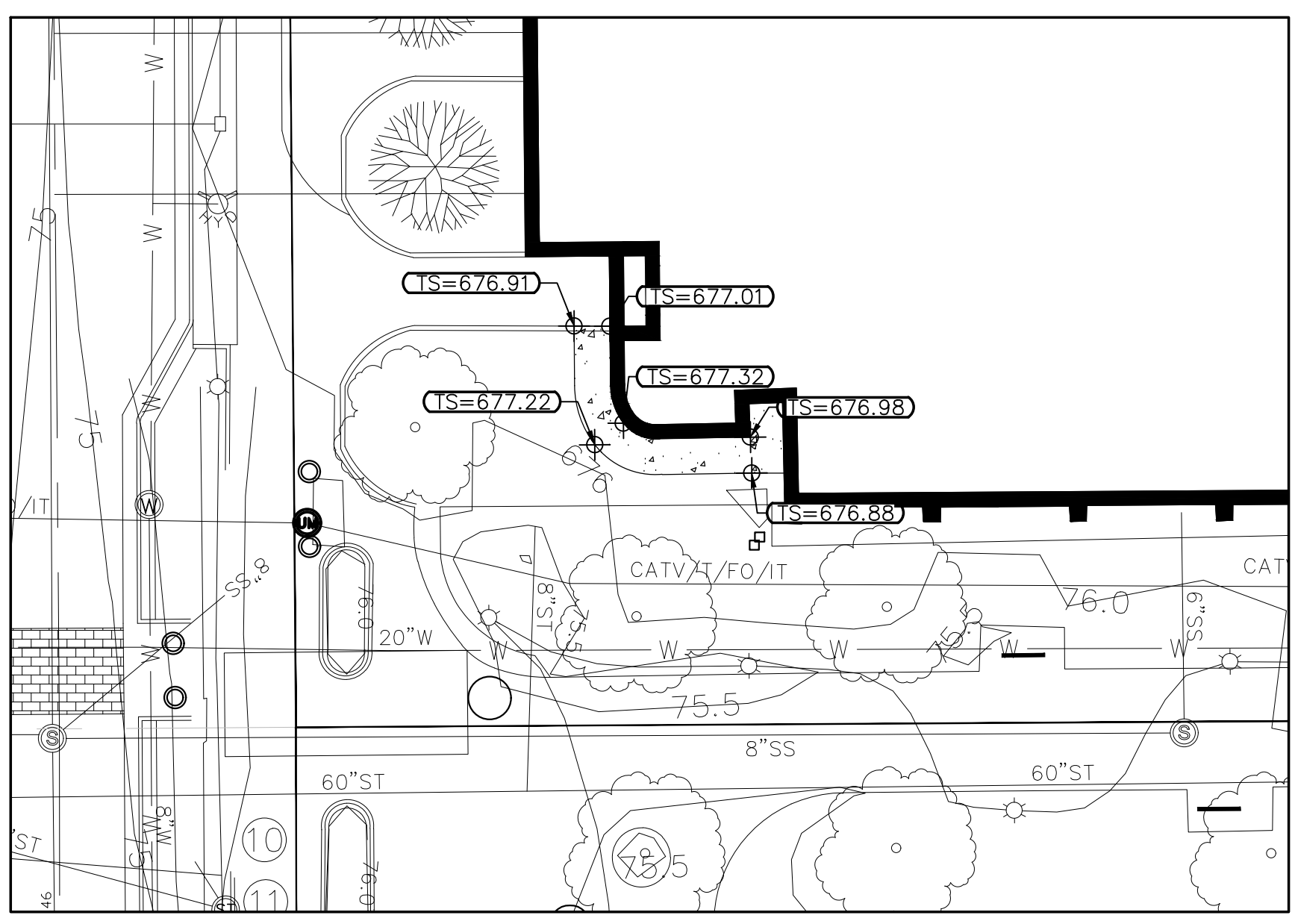
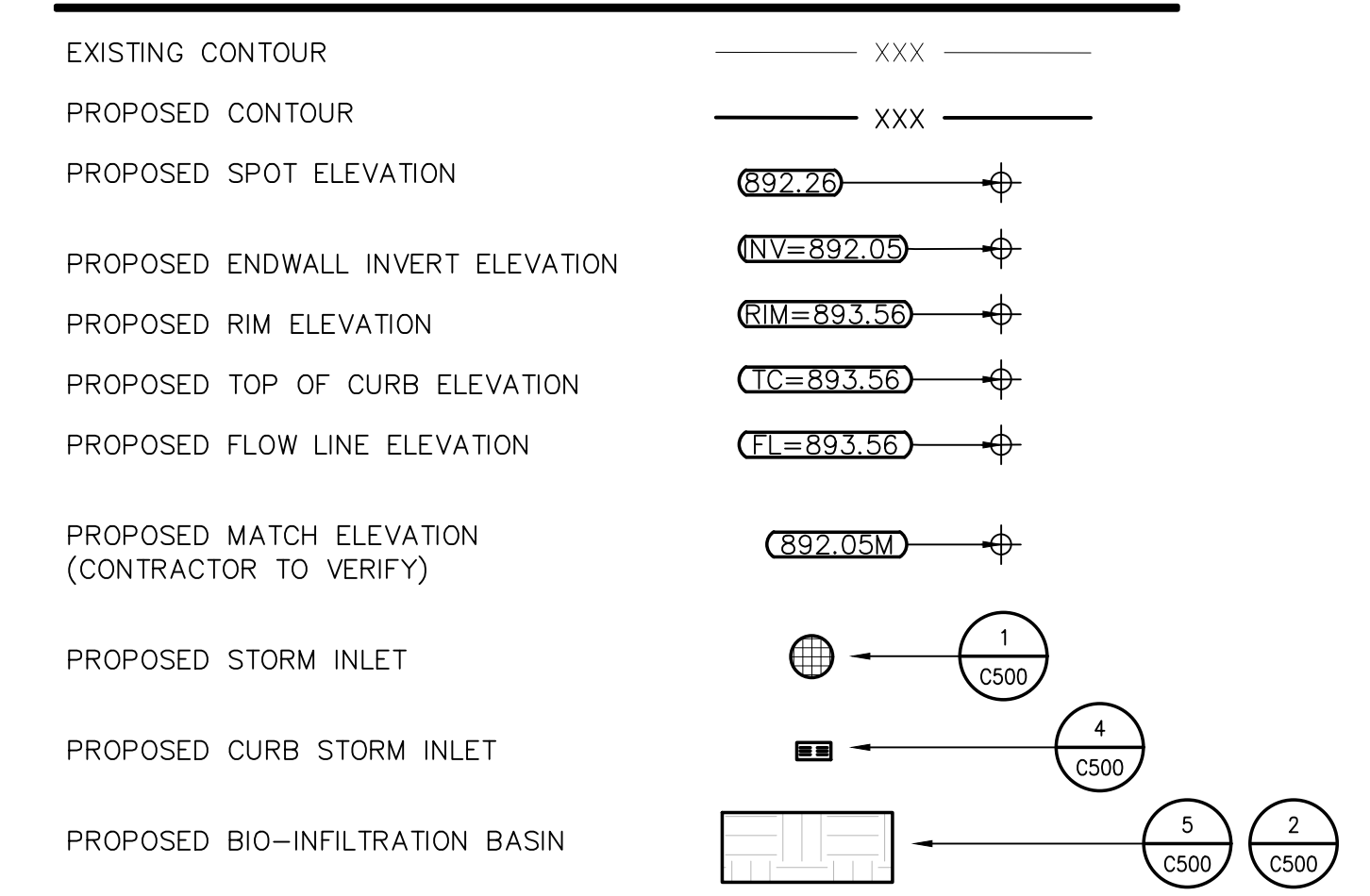

**INSTALLATION:**  
1. REMOVE INLET GRATE  
2. PLACE FABRIC OVER THE TOP OF THE CASTING  
3. PLACE THE GRATE BACK IN PLACE KEEPING A MINIMUM OF 8" OF FABRIC EXTENDING ON ALL SIDES

**MAINTENANCE:**  
CLEAN AS NEEDED TO MAINTAIN FLOW. DO NOT CUT OR RIP FABRIC TO INCREASE FLOWS. USE OF FABRIC WILL CREATE SHORT TERM PONDING OF WATER. DO NOT USE FABRIC INLET PROTECTION IF ADJACENT BUILDINGS OR PROPERTIES MAY BE DAMAGED BY PONDING WATER. ELEVATIONS ON SITE SHALL BE SUCH THAT ANY PONDED WATER WILL HAVE AN EMERGENCY OVERFLOW POINT AWAY FROM AREAS THAT MAY BE DAMAGED BY FLOODING.

**GENERAL NOTES:**  
USE ONLY THE FOLLOWING GEOTEXTILE FABRIC THAT ARE APPROVED BY THE WIDOT FOR USE AS INLET PROTECTION: A) LINDO INDUSTRIAL FABRICS - GTF 403 B) TC MIRAFIL FILTERWEAVE 401. FOR INLET PROTECTION, TYPE C, WITH A CURB BOX, AN ADDITIONAL 18" OF FABRIC IS WRAPPED AROUND THE WOOD AND SECURED WITH STAPLES.

**INLET PROTECTION** 3 C300

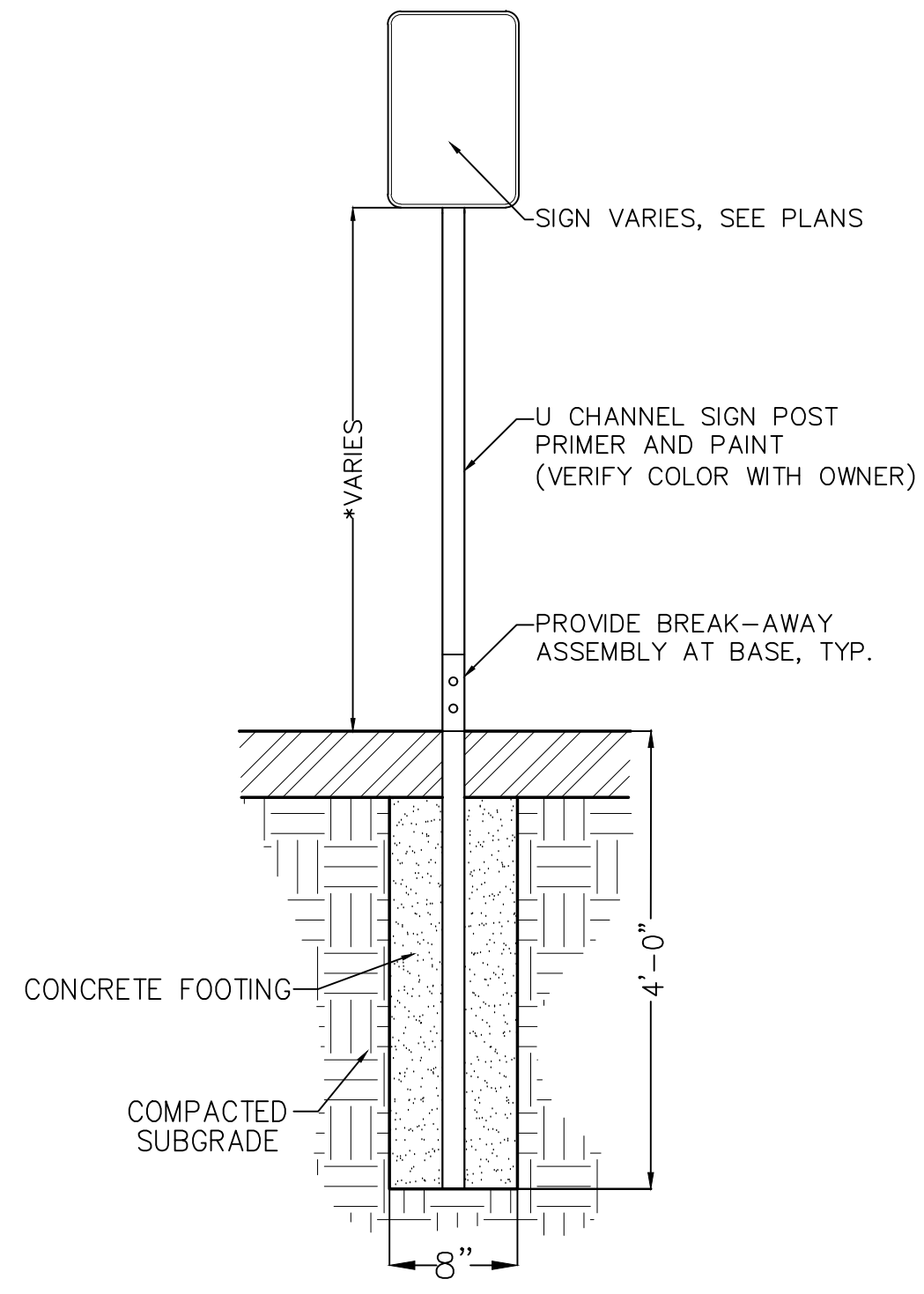

**NOTES:** \* ALL REGULATORY SIGNS SHOULD BE OF HEIGHT 6'-3". ALL OTHER SIGNS SHOULD BE HEIGHT OF 5'-0". CONFIRM SIGN HEIGHT WITH ENGINEER.

**SIGNAGE** 4 C300

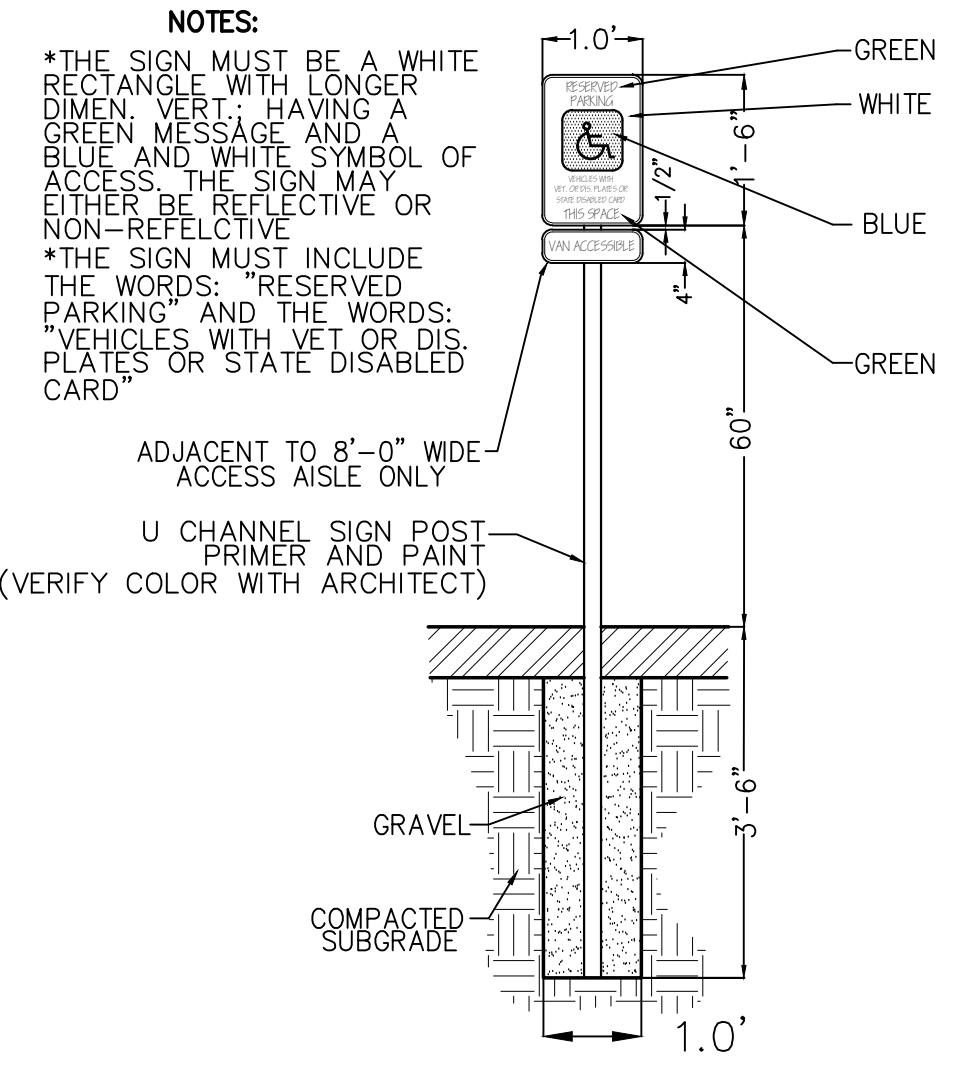
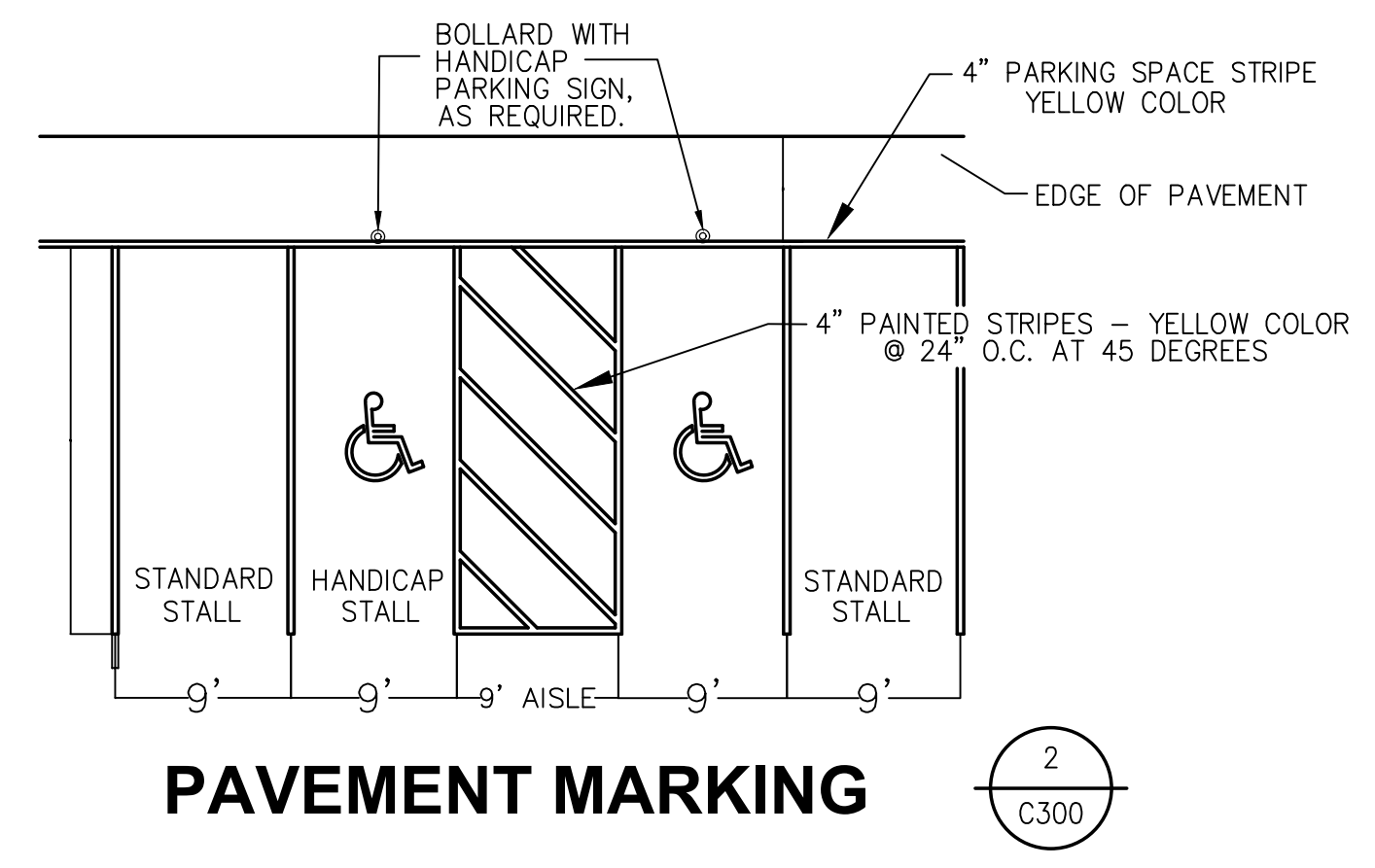
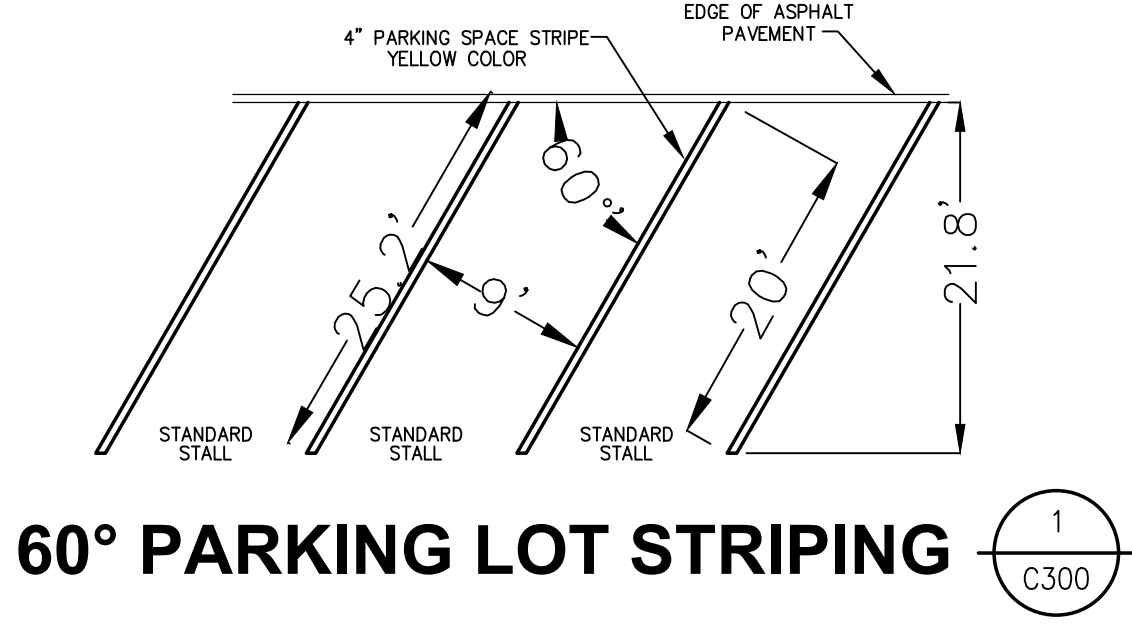

**ADA PARKING SIGN (TOPSOIL)** 5 C300

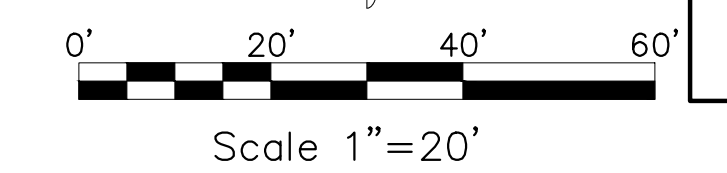
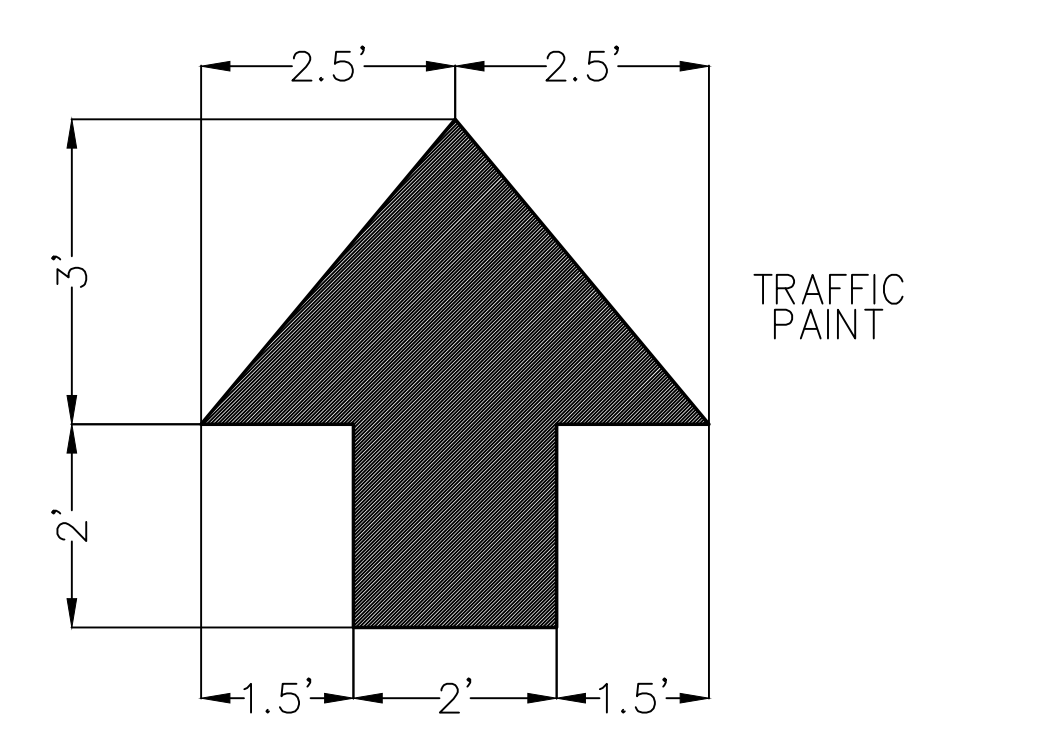

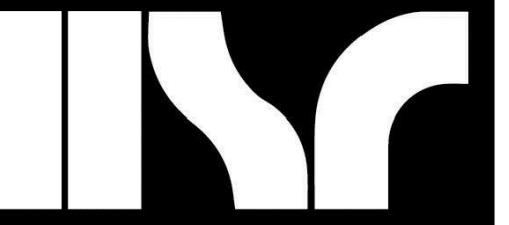

**HSR ASSOCIATES INC.**  
100 MILWAUKEE STREET  
LA CROSSE, WISCONSIN  
PHONE: 608.784.1830  
FAX: 608.782.5844  
www.hsrassociates.com

Consultant:



Point of Beginning

WESTERN TECHNICAL COLLEGE  
ARC & WELCOME CENTER PHASE 2 REMODEL

400 N. 7TH STREET  
LA CROSSE, WI 54601

EROSION CONTROL PLAN

Project Title: WESTERN TECHNICAL COLLEGE  
ARC & WELCOME CENTER PHASE 2 REMODEL

HSR Project Number: 18047

Project Date: 2/12/2019

Drawn By: AAS

Key Plan:

Revisions:

Graphic Scale: 1" = 20'

Last Update: 2/11/2019

Scale 1" = 20'

C400

**GENERAL NOTES:**

- CONTACT DIGGER'S HOTLINE 5 WORKING DAYS PRIOR TO THE START OF DEMOLITION/CONSTRUCTION.
- NOTIFY THE LOCAL MUNICIPALITY AT LEAST 2 WORKING DAYS PRIOR TO THE START OF SOIL DISTURBING ACTIVITIES.
- INSTALL ALL TEMPORARY EROSION CONTROL ELEMENTS PRIOR TO THE START OF DEMOLITION/CONSTRUCTION.
- ALL ACTIVITIES SHALL BE CONDUCTED IN A LOGICAL SEQUENCE AS TO MINIMIZE THE AMOUNT OF BARE SOIL EXPOSED AT ANY ONE TIME. MAINTAIN EXISTING VEGETATION AS LONG AS POSSIBLE.
- CRUSHED ROCK DRIVES FOR SEDIMENT TRACKING UTILIZING 3" CRUSHED ROCK SHALL BE MAINTAINED AT ALL CONSTRUCTION ENTRANCES TO THE SITE. THE ROCK DRIVE SHALL BE A MINIMUM OF 12" THICK AND BE A MINIMUM OF 50' FEET IN LENGTH BY THE WIDTH OF THE DRIVEWAY.
- OFF SITE SEDIMENT DEPOSITS OCCURRING AS A RESULT OF A STORM EVENT SHALL BE CLEANED UP BY THE END OF THE NEXT WORK DAY. ALL OFF SITE SEDIMENT DEPOSITS OCCURRING AS A RESULT OF CONSTRUCTION ACTIVITIES, INCLUDING SOIL TRACKED BY CONSTRUCTION TRAFFIC, SHALL AT A MINIMUM BE CLEANED BY THE END OF EACH WORK DAY. EXCESSIVE AMOUNTS OF SEDIMENT OR OTHER DEBRIS TRACKED ONTO ADJACENT STREETS BY THE USE OF MECHANICAL OR MANUAL SWEEPING OPERATIONS SHALL BE CLEANED FROM ADJACENT STREETS BY THE USE OF MECHANICAL OR MANUAL SWEEPING OPERATIONS ONCE A WEEK AT A MINIMUM AND BEFORE IMMINENT RAIN EVENTS.
- DISTURBED GROUND OUTSIDE OF THE EVERYDAY CONSTRUCTION AREAS, INCLUDING SOIL STOCKPILES, THAT IS LEFT INACTIVE FOR MORE THAN 7 DAYS SHALL BE TEMPORARILY STABILIZED BY SEEDING/MULCHING OR OTHER APPROVED METHODS.
- WASTE MATERIAL THAT IS GENERATED ON THE CONSTRUCTION SITE SHALL BE PROPERLY DISPOSED OF AND NOT ALLOWED TO RUN INTO RECEIVING WATERS.
- EROSION CONTROL DEVICES DESTROYED AS A RESULT OF CONSTRUCTION ACTIVITIES SHALL BE REPAIRED BY THE END OF EACH WORK DAY.
- INSPECT ALL EROSION CONTROL MEASURES AT LEAST ONCE A WEEK AND AFTER ANY RAINFALL OF 0.5" OR MORE. MAKE NEEDED REPAIRS AND DOCUMENT ALL ACTIVITIES AS PER THE REQUIREMENTS OF THE NOTICE OF INTENT SUBMITTED BY THE PROJECT CIVIL ENGINEER.
- ALL TEMPORARY EROSION CONTROL ELEMENTS SHALL REMAIN IN PLACE UNTIL A SUFFICIENT GROWTH OF VEGETATION IS ESTABLISHED AND THEN BE REMOVED AS PART OF THE BASE BID.
- IF SEDIMENT LADEN WATER NEEDS TO BE REMOVED FROM THE SITE, FILTER BAGS OR SCREENING SHALL BE USED IN ACCORDANCE WITH WDNR TECHNICAL STANDARD 1061 TO PREVENT SEDIMENT DISCHARGE TO THE MAXIMUM EXTENT PRACTICABLE.
- PROVIDE RIP RAP AT PROPOSED CULVERT ENDWALL STRUCTURES TO PREVENT WASHOUT AND EROSION.
- RIP RAP SHALL HAVE WisDOT TYPE HR FILTER FABRIC PLACED BENEATH.
- IF BARE SOIL IS EXPOSED DURING THE WINTER MONTHS, STABILIZATION BY MULCHING OR ANIONIC POLYACRYLAMIDE SHALL OCCUR PRIOR TO SNOW OR FROZEN GROUND.
- SILT FENCE SHALL BE INSTALLED AROUND THE TOPSOIL STOCKPILE.
- SILT FENCE SHALL BE INSTALLED AROUND THE BIORETENTION AREA IMMEDIATELY FOLLOWING INSTALLATION OF THE ENGINEERED SOIL TO PROTECT IT FROM SILT CONTAMINATION.
- THE ENGINEERED SOIL SHALL NOT BE PLACED IN THE BIORETENTION AREAS UNTIL THE SURROUNDING DRAINAGE AREA HAS BEEN FULLY STABILIZED. ALL CONSTRUCTION SITE SEDIMENT SHALL BE REMOVED FROM THE SUBGRADE OF THE BIORETENTION AREA PRIOR TO PLACEMENT OF THE ENGINEERED SOIL.
- THE CONTRACTOR SHALL PERFORM INSPECTIONS AND MONITORING OF EROSION CONTROL PRACTICES IN ACCORDANCE WITH THE W DNR "CONSTRUCTION SITE INSPECTION REPORT" FORM 3400-187. THIS FORM CAN BE FOUND IN THE CONSTRUCTION SPECIFICATIONS.

**EROSION CONTROL LEGEND:**

EXISTING CONTOUR	---	885
PROPOSED CONTOUR	---	888
PROPOSED INLET PROTECTION		
STORM WATER OVERLAND FLOW DIRECTION	---	
LIGHT RIP RAP W/FILTER FABRIC BENEATH		

**EROSION CONTROL SEQUENCING**

- INSTALL PERIMETER EROSION CONTROL
- BEGIN DEMOLITION
- BEGIN ROUGH GRADING AND UTILITY INSTALLATION
- DURING GRADING ACTIVITIES EXISTING GRASS AND VEGETATION, TO BE REMOVED, SHALL REMAIN IN PLACE FOR AS LONG AS POSSIBLE, TO AVOID SEDIMENT TRANSPORT.
- TEMPORARY STABILIZATION ACTIVITY SHALL COMMENCE WHEN LAND DISTURBING CONSTRUCTION ACTIVITIES HAVE TEMPORARILY CEASED AND WILL NOT RESUME FOR A PERIOD EXCEEDING 14 CALENDAR DAYS.
- FINAL STABILIZATION ACTIVITY SHALL COMMENCE WHEN LAND DISTURBING ACTIVITIES CEASE AND FINAL GRADE HAS BEEN REACHED ON ANY PORTION OF THE SITE.
- ANY CONSTRUCTION SITE SEDIMENT BUILD UP SHALL BE REMOVED FROM THE PROPOSED BIO-RETENTION BASIN BEFORE EXCAVATION TO THE FINAL DEPTH AND INSTALLATION OF THE ENGINEERED SOIL.
- IF DISTURBED AREAS MUST BE LEFT OVER WINTER, AN ANIONIC POLYACRYLAMIDE SHALL BE APPLIED TO ALL DISTURBED AREAS PRIOR TO GROUND FREEZE.

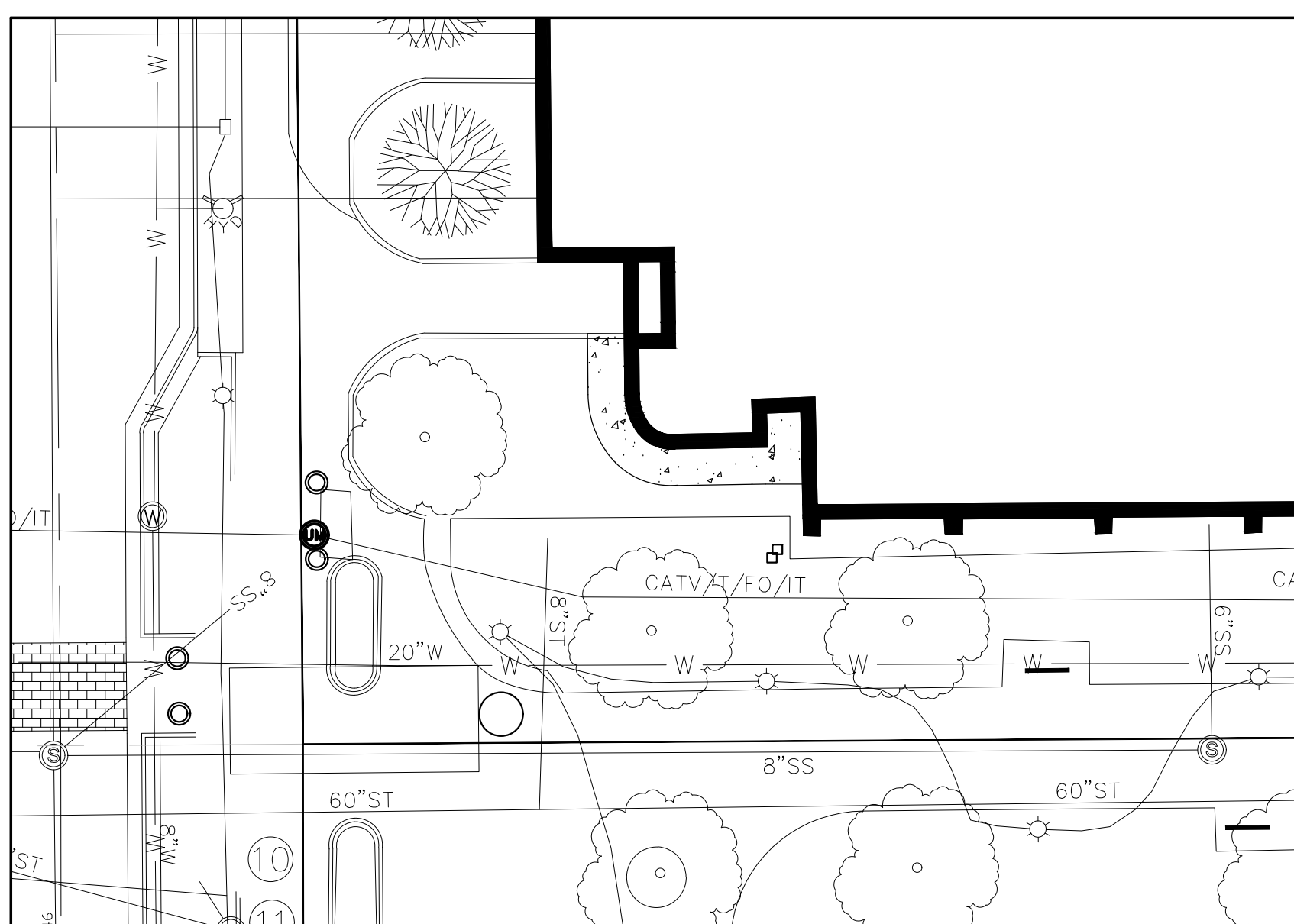
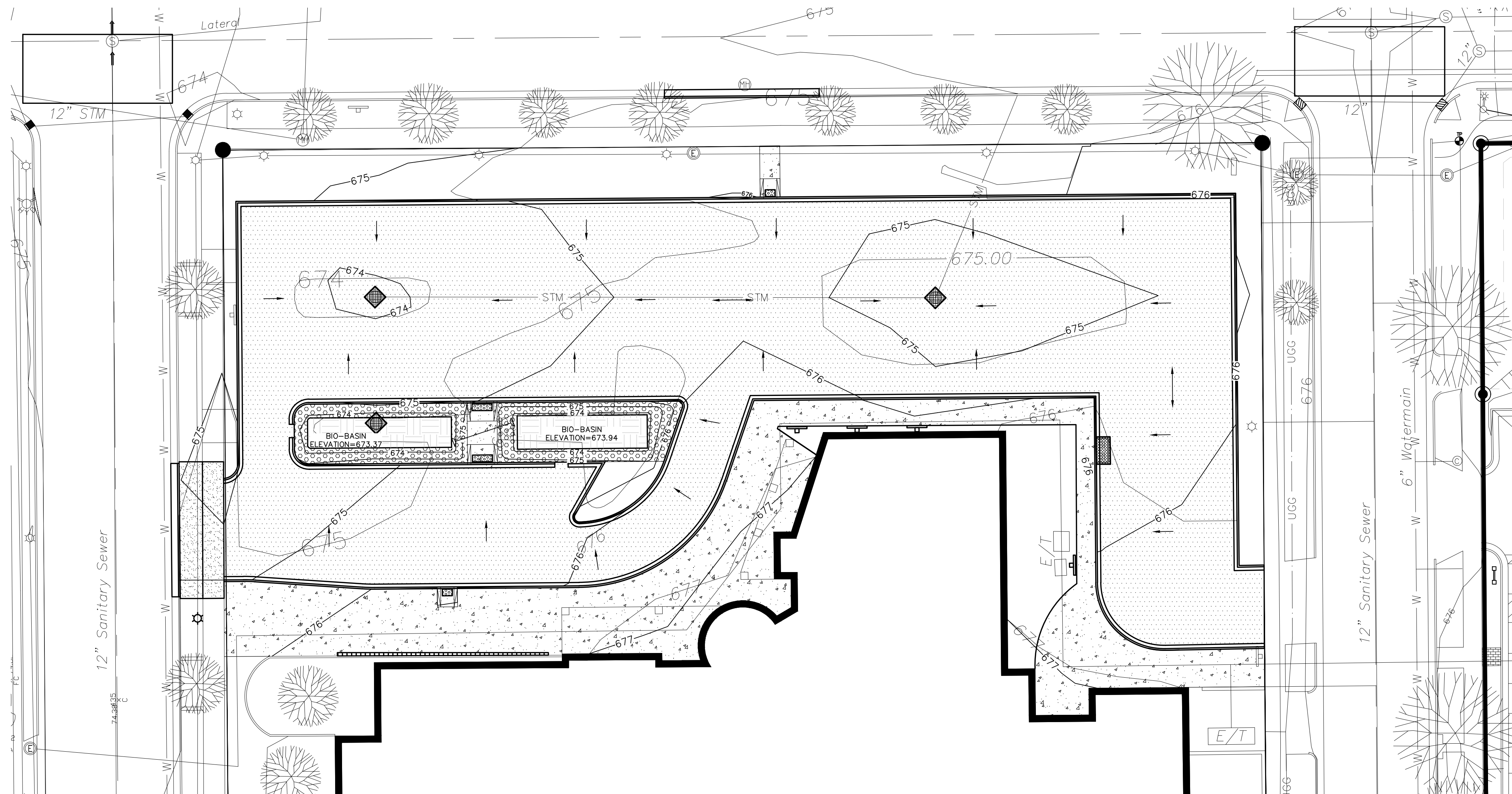

**CURB CUT & LIGHT RIP RAP**

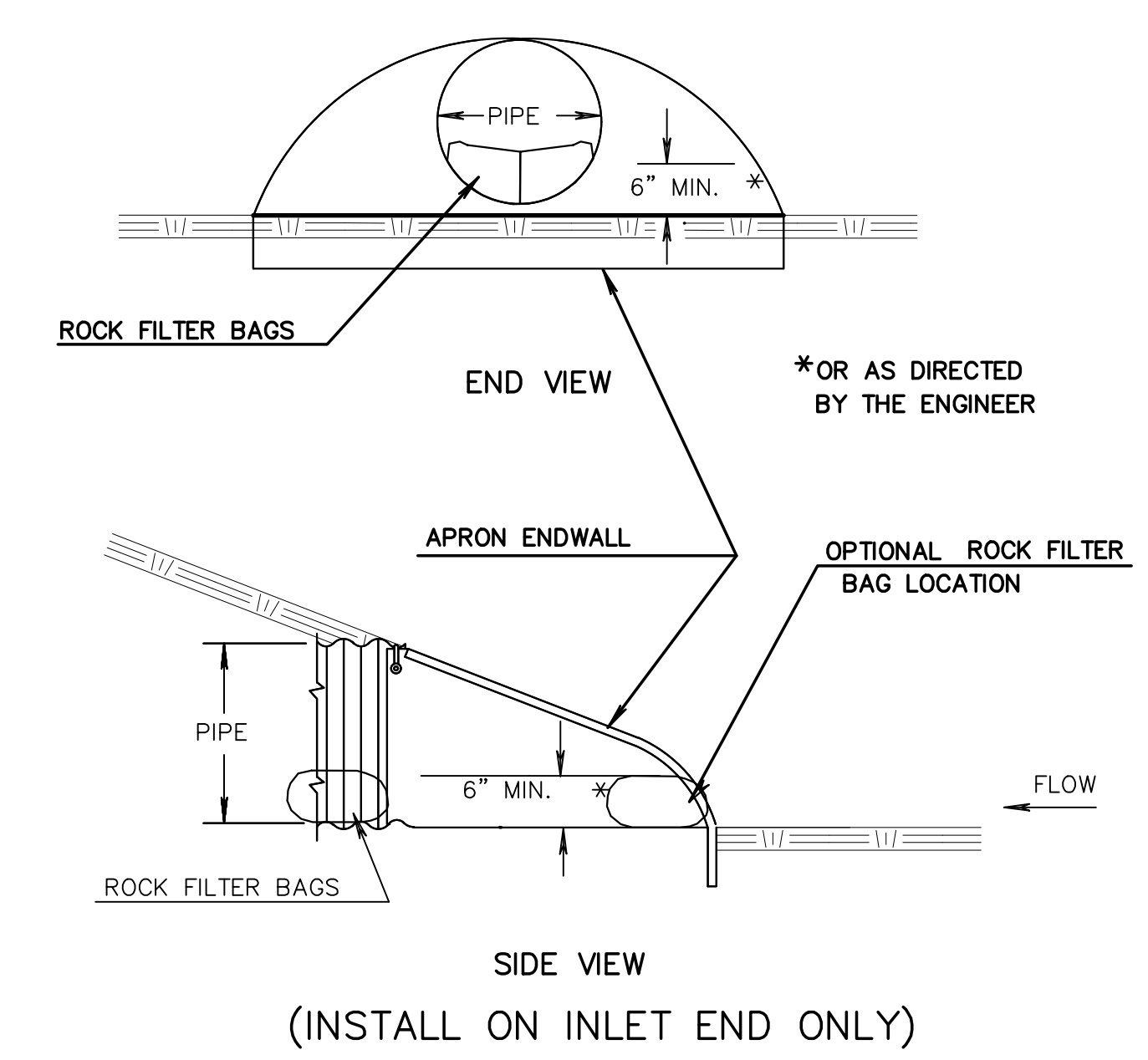

**ROCK FILTER BAG**

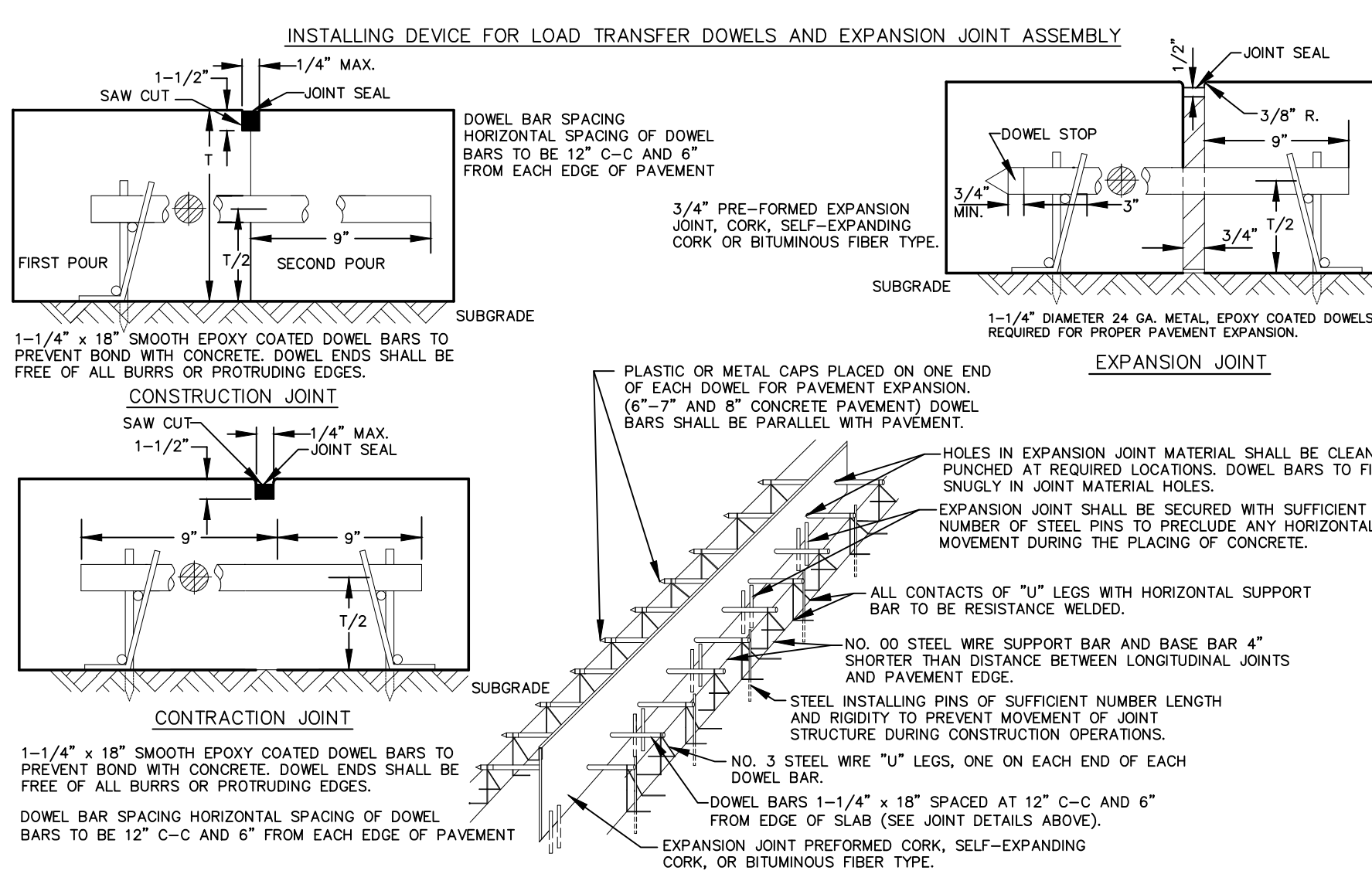

**PCC PAVEMENT CONSTRUCTION JOINTS**

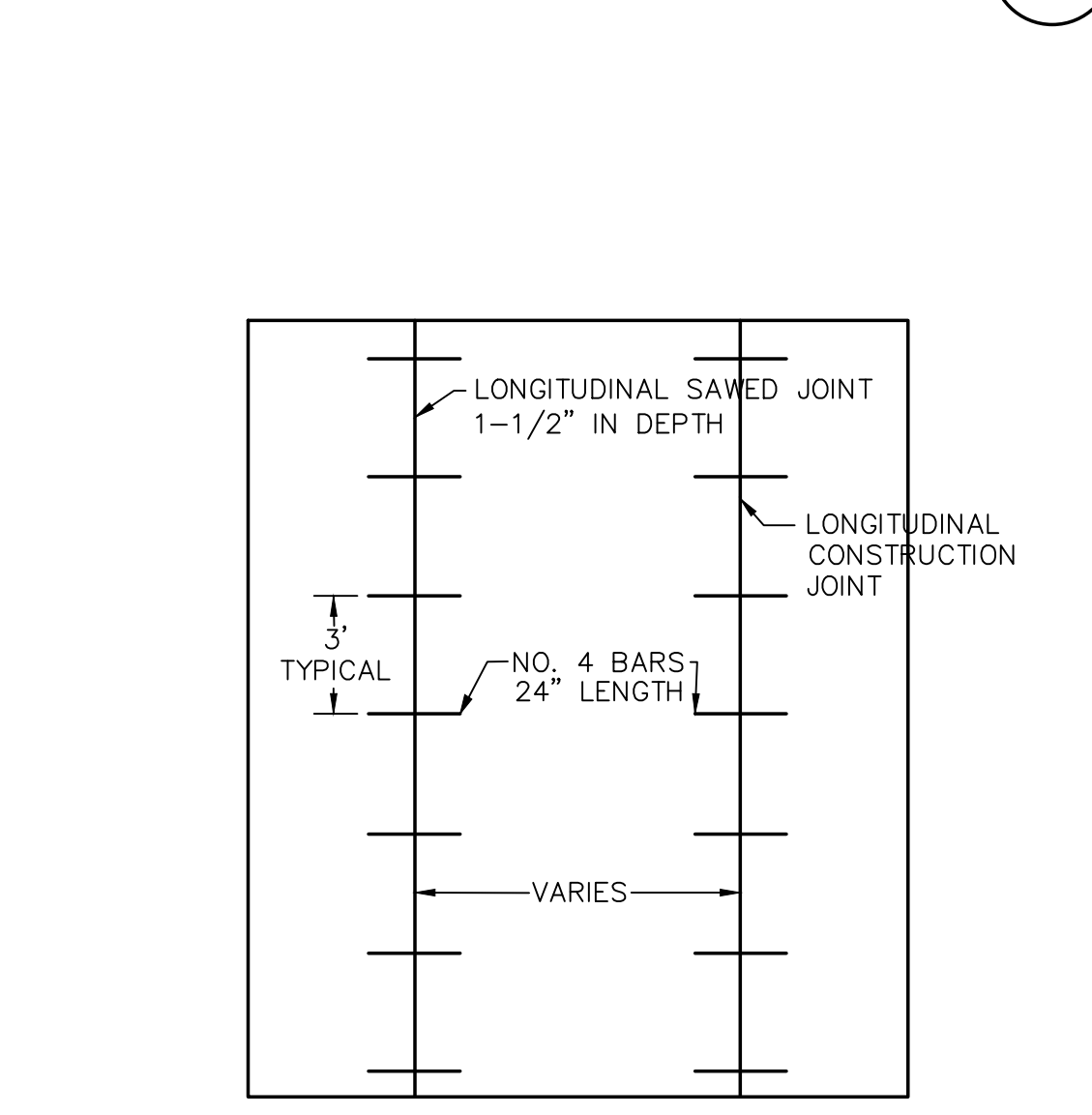

**PCC PAVEMENT LONGITUDINAL JOINTS**

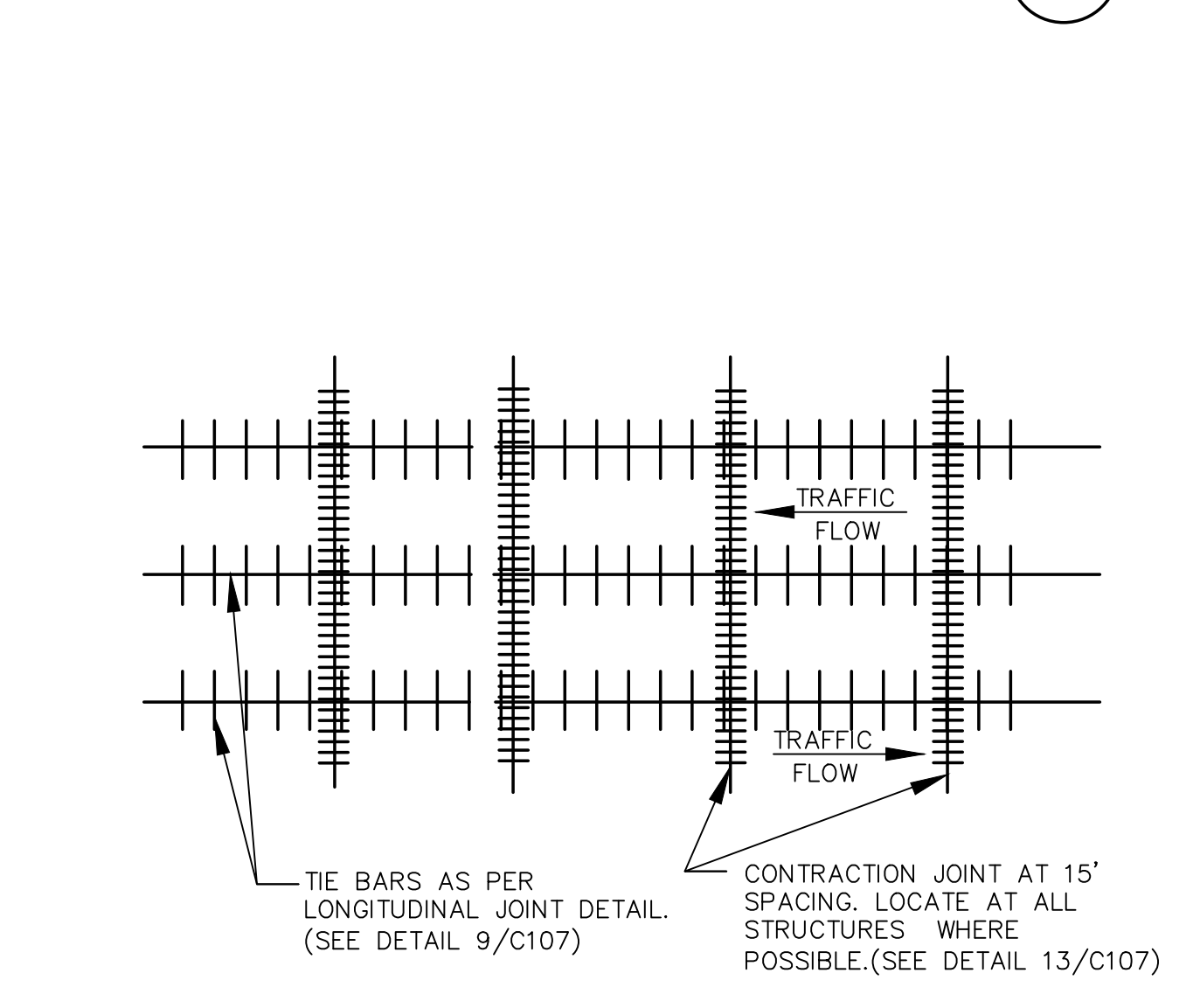

**PCC PAVEMENT JOINT LAYOUT**

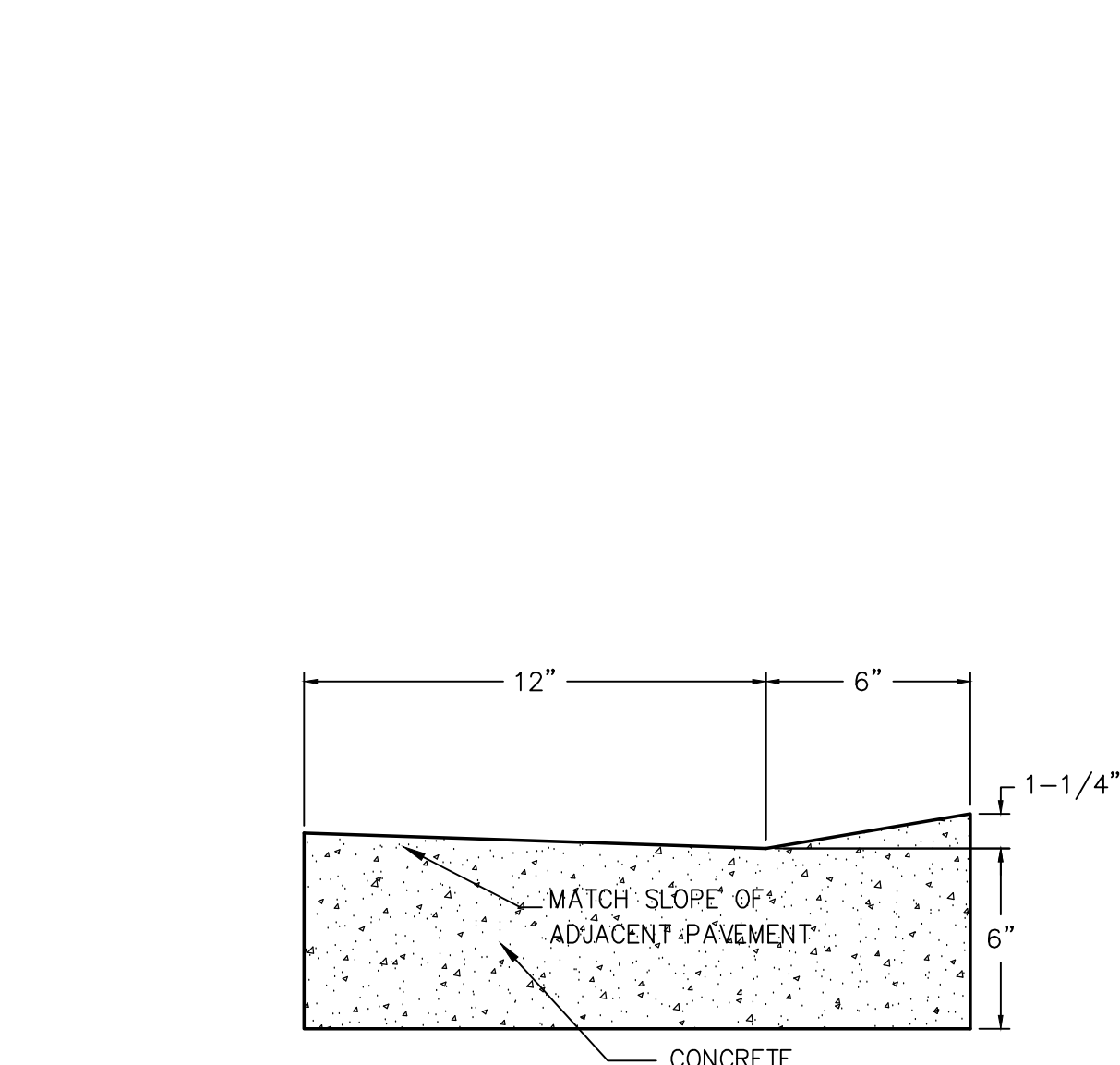

**DRIVE OVER CURB**



**C400**

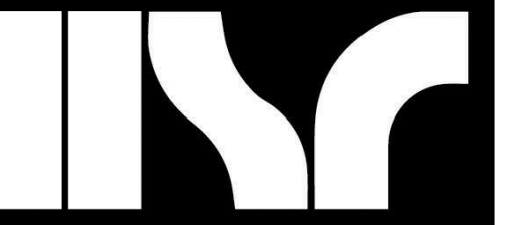

**HSR ASSOCIATES INC.**  
100 MILWAUKEE STREET  
LA CROSSE, WISCONSIN  
PHONE: 608.784.1830  
FAX: 608.782.5844  
www.hsrassociates.com

Consultant:  
**POB**  
Point of Beginning

WESTERN TECHNICAL COLLEGE  
ARC & WELCOME CENTER PHASE 2 REMODEL

Project Location: 400 N. 7TH STREET  
LA CROSSE, WI 54601

Utility Plan

HSR Project Number: 18047  
Project Date: 2/12/2019  
Drawn By: AAS

Key Plan:

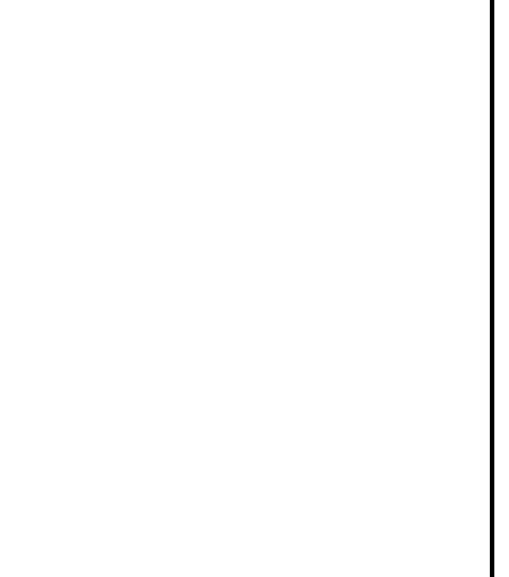

Revisions:



Graphic Scale: 1" = 20'  
Last Update: 2/11/2019

**C500**

**GENERAL NOTES:**

- CONTACT DIGGER'S HOTLINE 5 WORKING DAYS PRIOR TO THE START OF CONSTRUCTION.
- GRADE, LINE, AND LEVEL SHALL BE REVIEWED IN THE FIELD BY THE CONSTRUCTION MANAGER.
- ANY EXISTING UTILITIES NOT SHOWN ON THIS DOCUMENT WHICH NEED TO BE REMOVED, RELOCATED OR ADJUSTED SHALL BE THE RESPONSIBILITY OF THE SITE GRADING CONTRACTOR.
- COORDINATE ALL UTILITY WORK WITH THE RESPECTIVE TRADES RESPONSIBLE FOR THE INSTALLATION OF GAS, CABLE, TELEPHONE AND ELECTRICAL (INCLUDING MAIN SERVICE, SITE LIGHTING, CONDUITS AND SIGNAGE).
- COORDINATE ALL WORK WITHIN THE PUBLIC RIGHT OF WAY WITH THE LOCAL MUNICIPALITY.
- TESTING AND INSPECTION SHALL BE DONE IN ACCORDANCE WITH SPS 382.21.
- THE MUNICIPALITY SHALL BE CONTACTED PRIOR TO ANY EXCAVATION IN THE PUBLIC RIGHT-OF-WAY AND PRIOR TO CONNECTING SANITARY SEWER AND WATER LATERALS TO THE PUBLIC MAINS. THE CONTRACTOR SHALL HAVE A TRAFFIC CONTROL PLAN APPROVED PRIOR TO WORK COMMENCING. THE MUNICIPALITY SHALL OPERATE EXISTING WATER VALVES, IF NEEDED.
- PROVIDE RIP RAP AT PROPOSED CULVERT ENDWALL STRUCTURES TO PREVENT WASHOUT AND EROSION.
- RIP RAP SHALL HAVE WISDOT TYPE HR FILTER FABRIC PLACED BENEATH.

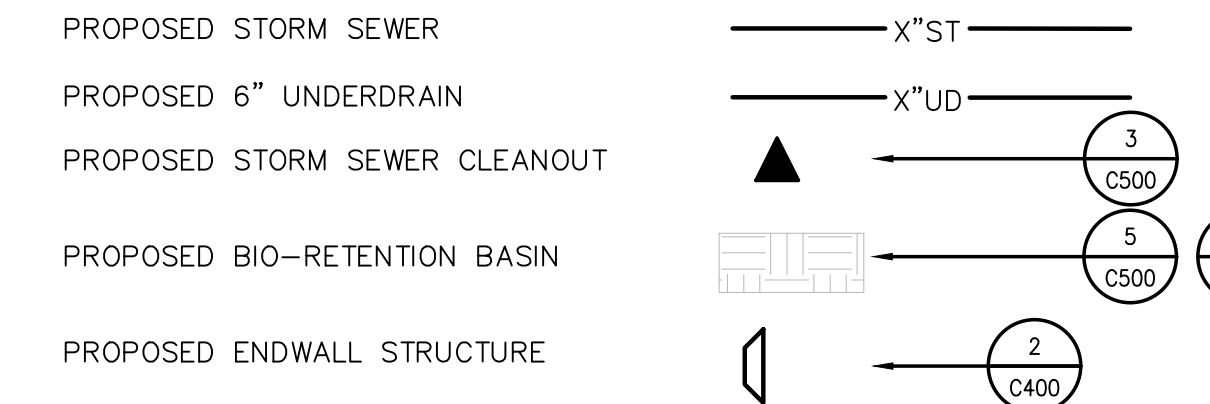
**UTILITY LEGEND:**



**STORM MANHOLE SCHEDULE:**

ST#1	ST#2
RIM INV. N 673.87 671.23	RIM INV. NE 675.24 672.74
DEPTH 2.64	DEPTH 2.5
48" I.D. PRECAST MANHOLE W/ NEENAH R-1710 CASTING W/ TYPE "A" COVER	2'X3' CURB BOX INLET W/ NEENAH R-3085 CASTING W/ TYPE "C" COVER
EX ST#1 RIM E 673.86 INV. E 671.14 INV. S 671.14 DEPTH 2.72	EX ST#2 RIM W 674.35 INV. W 670.27 INV. SW 670.27 INV. NW 670.27 DEPTH 4.08
48" I.D. PRECAST MANHOLE W/ NEENAH R-1710 CASTING W/ TYPE "A" COVER	48" I.D. PRECAST MANHOLE W/ NEENAH R-1710 CASTING W/ TYPE "A" COVER

**CLEAN OUT SCHEDULE:**

CO#1	CO#2
RIM INV. 673.37 671.23	RIM INV. 673.94 671.24
DEPTH 2.72	DEPTH 2.70
6" UNDERDRAIN	6" UNDERDRAIN

\* NOTE: INVERT ELEVATION SHOWN AT 90° BEND/VERTICAL RISER

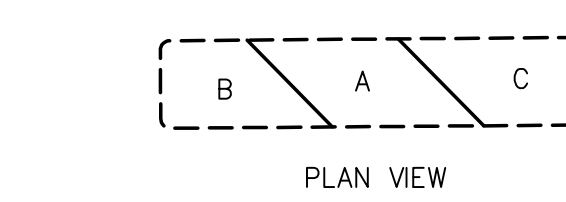

PLANT CLUSTER SIZE	TOTAL PLUGS
A	PLUG 70
B	PLUG 60
C	PLUG 60

BOTANICAL NAME	COMMON NAME
A- ASTER NOVAE-ANGIAE	NEW ENGLAND ASTER
B- ASCLEPIAS INCARNATA	RED MILKWEED
C- LIATRIS PYNOSTACHYA	PRAIRIE BLAZINGSTAR

\*\*1 PLUG FOR EVERY 2. SQUARE FEET

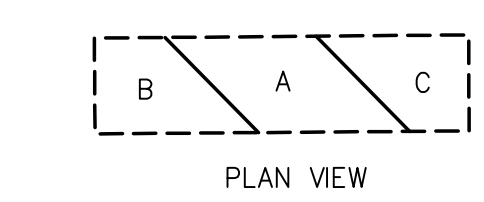

PLANT CLUSTER SIZE	TOTAL PLUGS
A	PLUG 80
B	PLUG 60
C	PLUG 60

BOTANICAL NAME	COMMON NAME
A- ASTER NOVAE-ANGIAE	NEW ENGLAND ASTER
B- ASCLEPIAS INCARNATA	RED MILKWEED
C- LIATRIS PYNOSTACHYA	PRAIRIE BLAZINGSTAR

\*\*1 PLUG FOR EVERY 2. SQUARE FEET

**BIO-RETENTION AREA (EAST)**

**BIO-RETENTION AREA (WEST)**

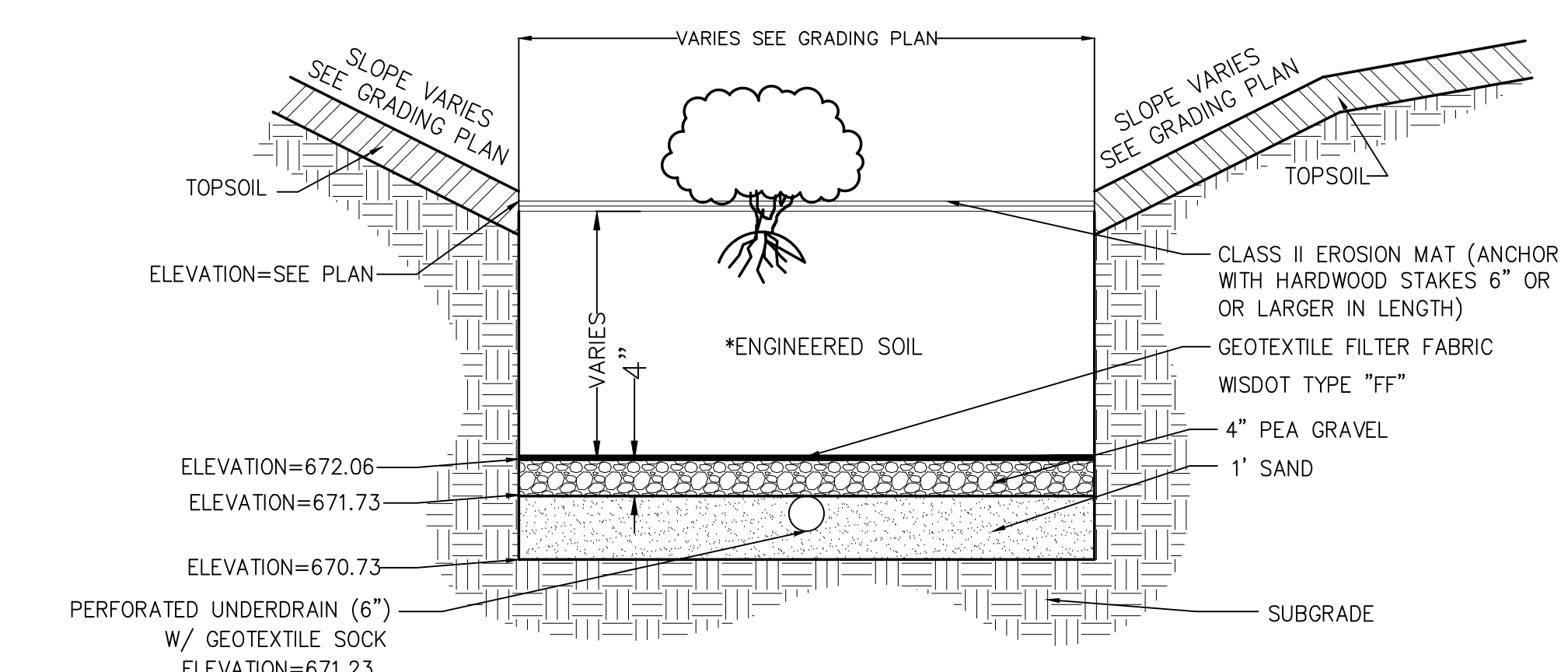

- NOTES:**
- ENGINEERED SOIL SHALL NOT BE INSTALLED UNTIL GRADING IS COMPLETE AND DISTURBED GROUND HAS BEEN TEMPORARILY STABILIZED TO PREVENT CLOGGING.
  - ENGINEERED SOIL SHOULD CONSIST OF CONCRETE SAND, .02-.04 INCHES.
  - DO NOT ADD ENGINEERED MEDIA UNTIL SITE PAVING HAS OCCURRED AND TURF AREAS HAVE BEEN ESTABLISHED WITH VEGETATION.
  - ENGINEERED MEDIA TO BE INSTALLED WITH NO MECHANICAL COMPACTION (INCLUDING EQUIPMENT TRACKING).
  - ENGINEERED MEDIA TO BE INSTALLED IN 6 INCH LIFTS AND SPRINKLER WATERED (TO SIMULATE RAINFALL) AT EACH LIFT TO ACHIEVE SETTLEMENT. ALTERNATELY, ENGINEERED MEDIA MAY BE PLACED IN 6 INCH LIFTS WITHOUT WATERING AND FINISHED GRADE PLACED 3 INCHES ABOVE THE PLAN ELEVATION TO ACCOUNT FOR EXPECTED SETTLEMENT DURING INITIAL RAINFALLS.
  - IF IN SITU SOILS DO NOT MEET THE REQUIREMENTS OF A TYPE B CLAY LINER IN APPENDIX D OF THE WOPR TECHNICAL STANDARD 1001, THE CONTRACTOR SHALL OVER EXCAVATE THE POND BY 2 FOOT, AND INSTALL A CLAY LINER THAT MEETS THE ABOVEMENTIONED SPECIFICATIONS. THE CONTRACTOR MAY USE OTHER LINER METHODS LISTED IN THE AFOREMENTIONED APPENDIX D, IF APPROVED BY THE CIVIL ENGINEER.

**BIO-RETENTION BASIN**

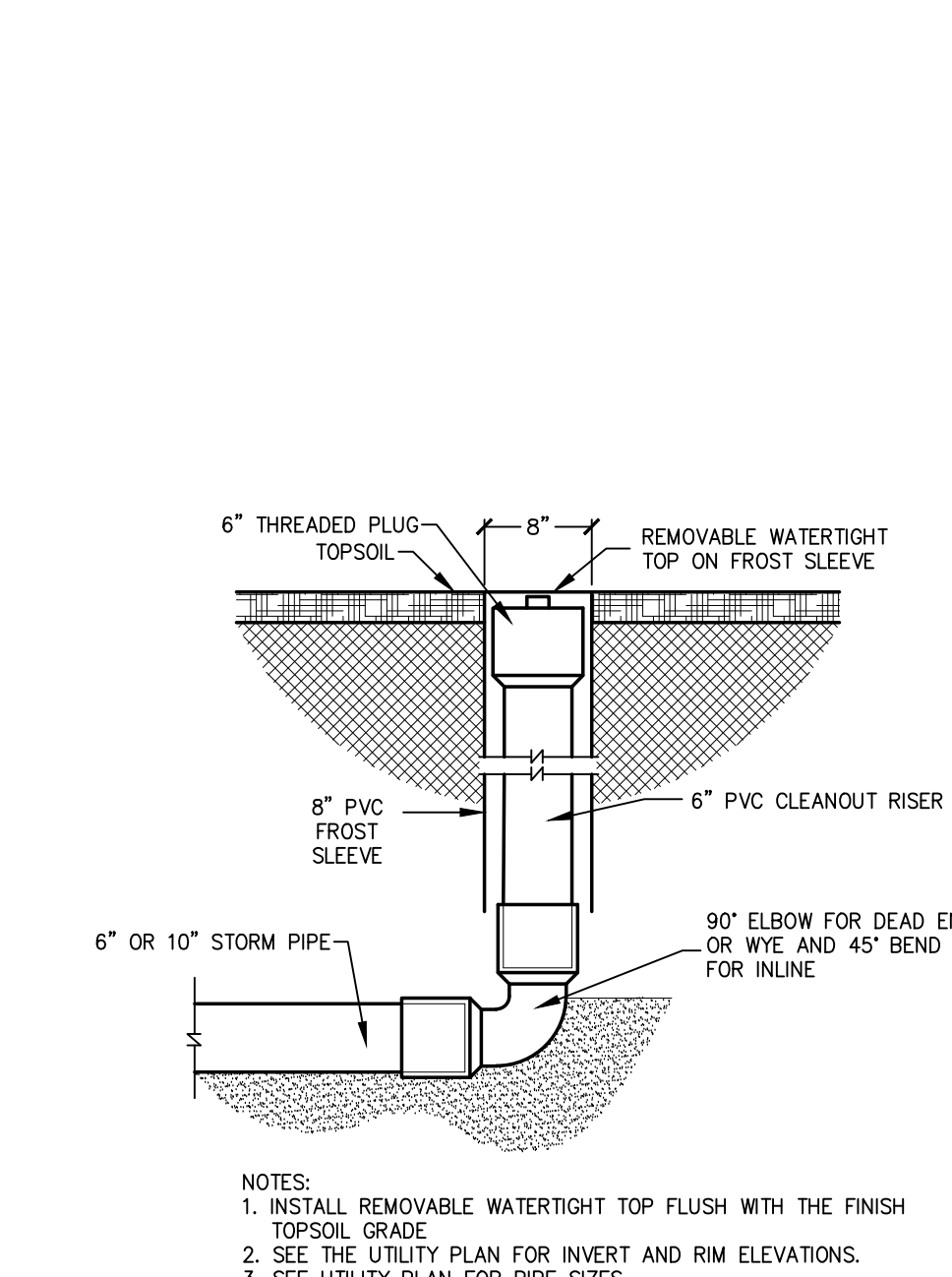
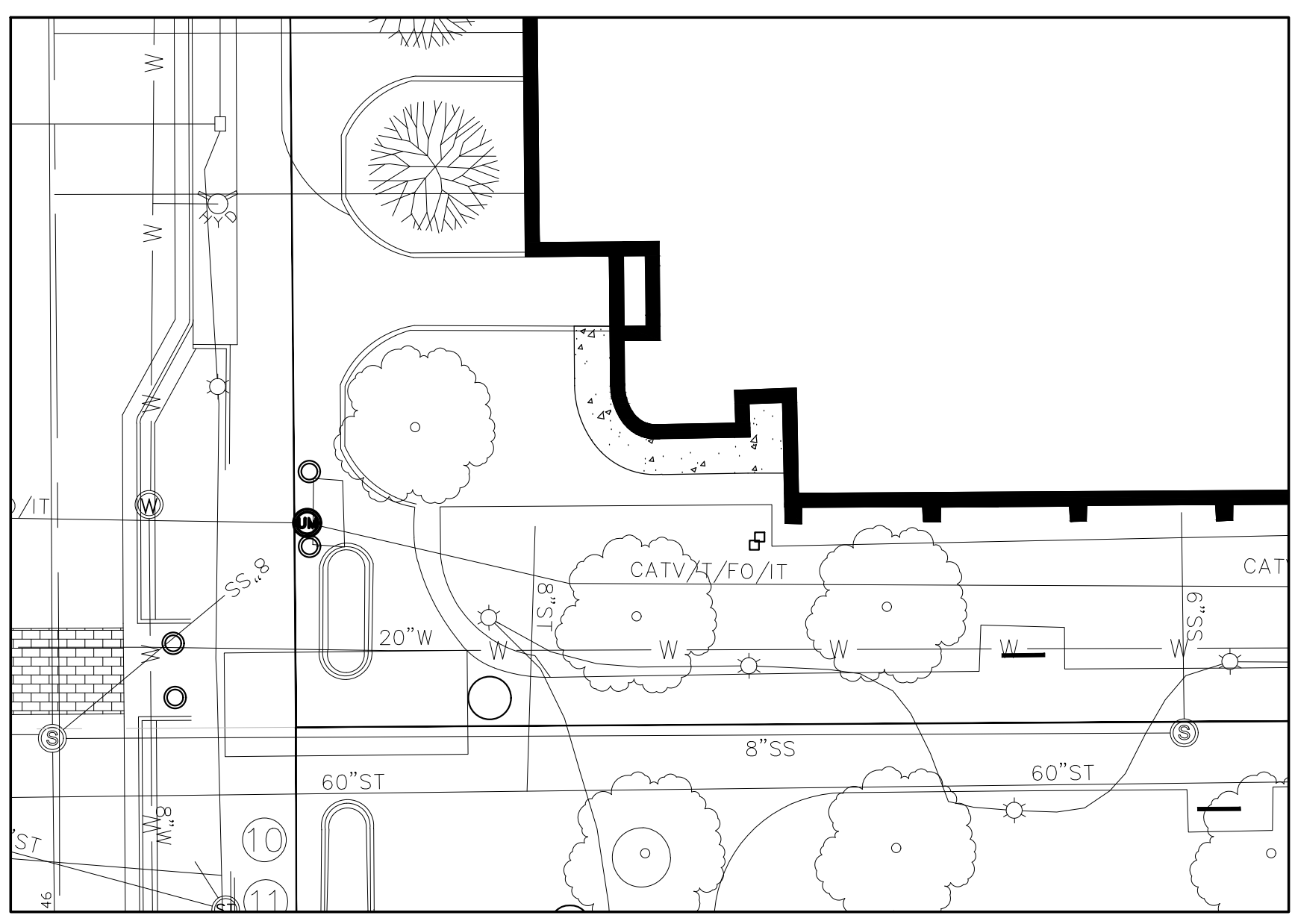
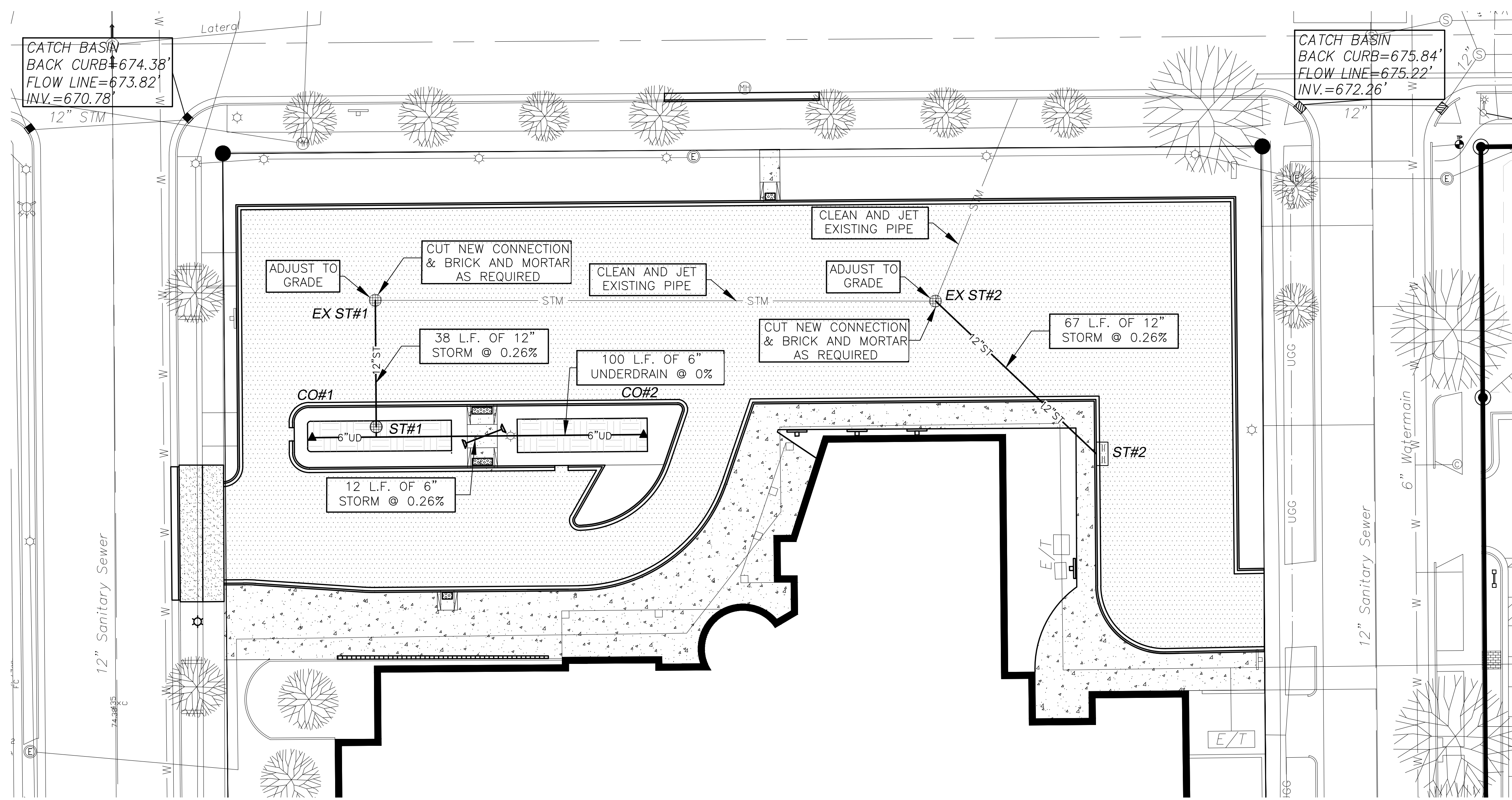

**STORM SEWER CLEANOUT**

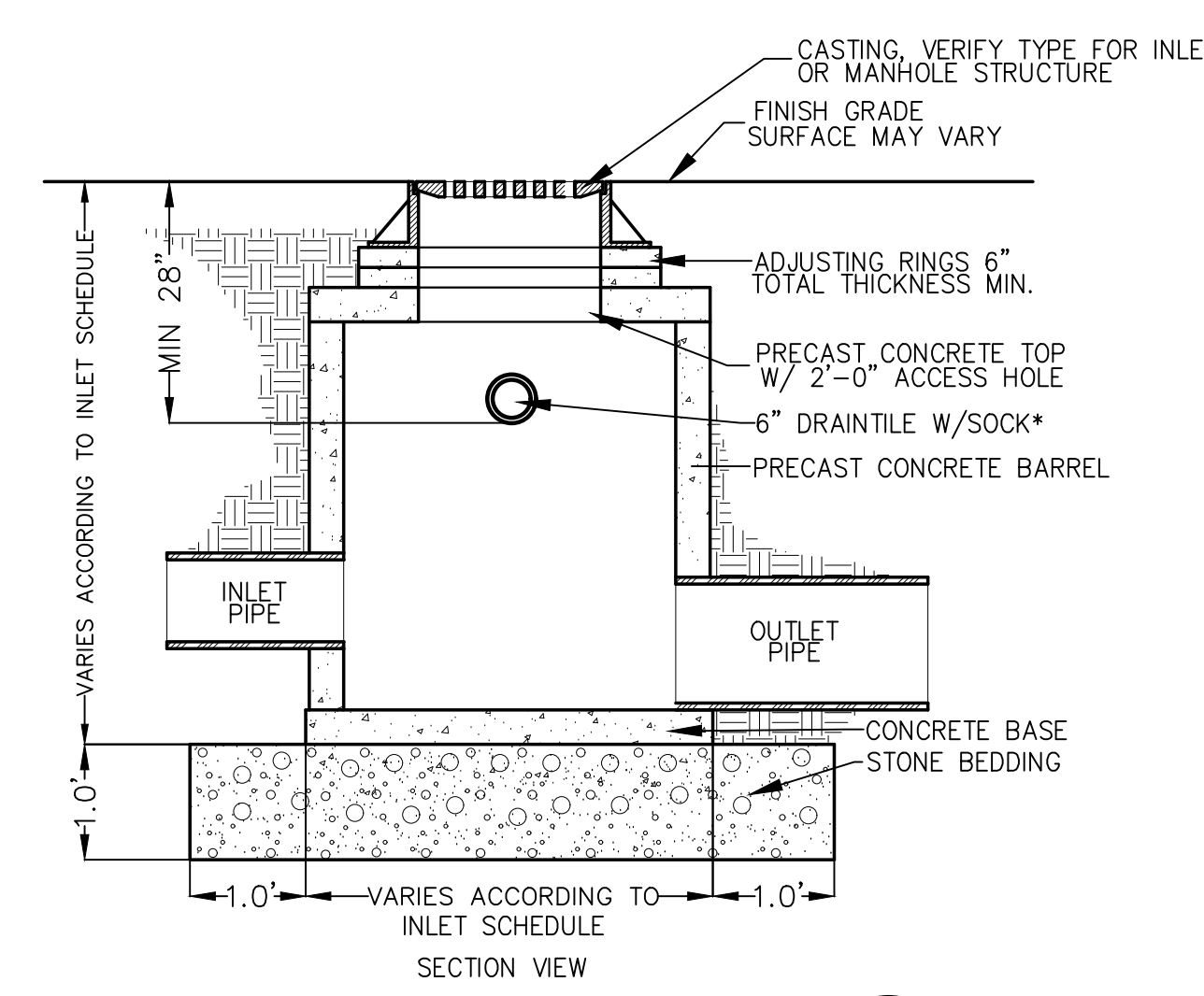

**STORM MANHOLE**

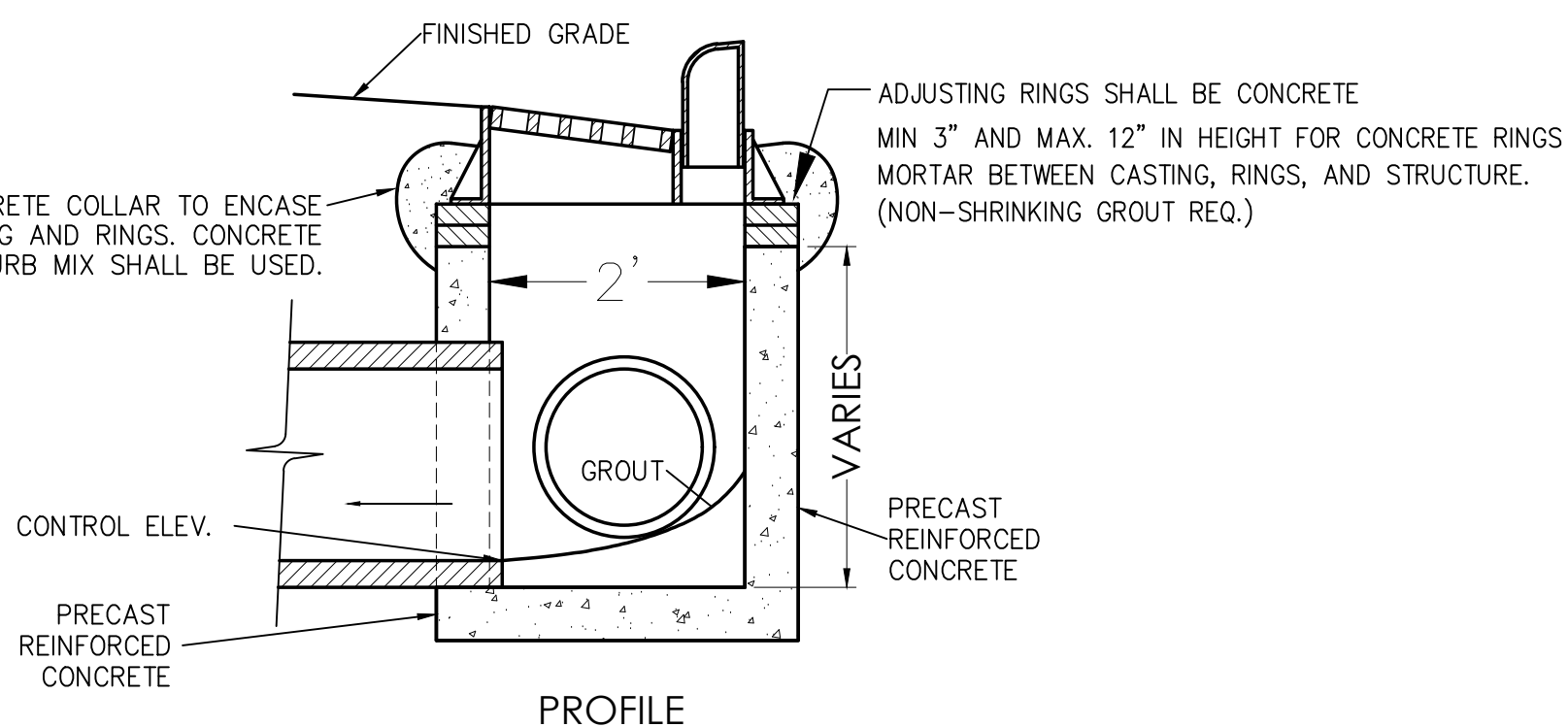
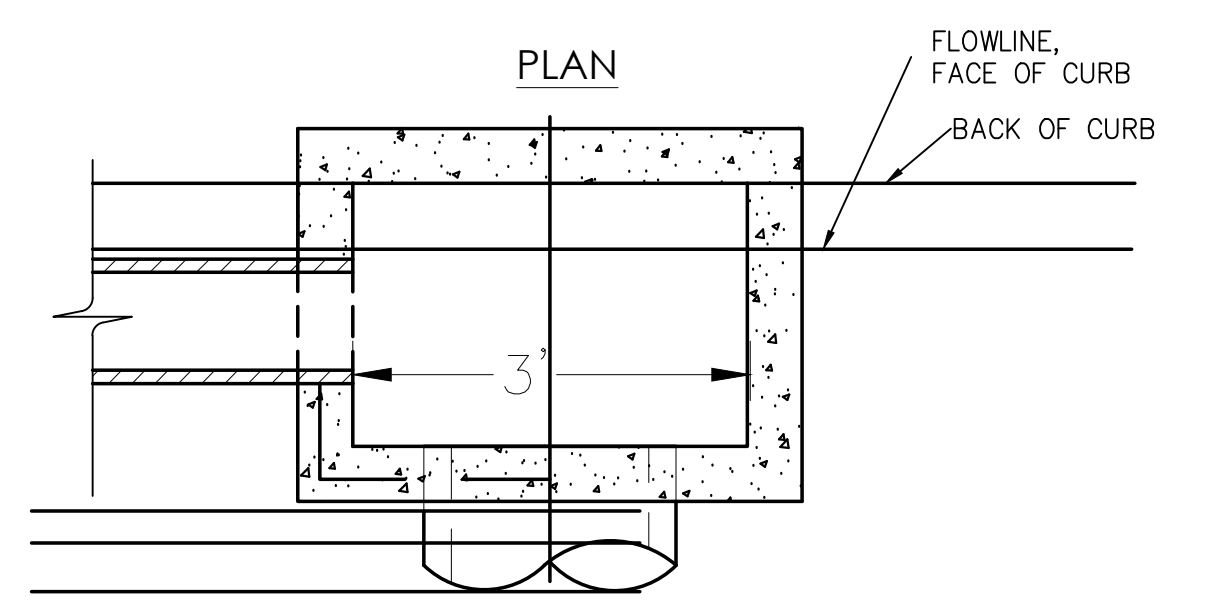

**2'X3' BOX CATCH BASIN**

