

BORTON CONSTRUCTION NEW OFFICE

CITY SDP SUBMITTAL

LA CROSSE, WISCONSIN

ISG PROJECT # 26-34320



LOCATION MAP

SHEET INDEX

- C0-00 TITLE SHEET
- C0-01 LEGEND AND NOTES
- C0-20 TYPICAL DETAILS
- C0-21 TYPICAL DETAILS
- C0-22 TYPICAL DETAILS
- C0-23 TYPICAL DETAILS
- C1-10 SWPPP NARRATIVE
- C1-11 SWPPP NARRATIVE
- C1-12 SWPPP DETAILS
- C1-13 PRE CONSTRUCTION SWPPP
- C1-14 POST CONSTRUCTION SWPPP
- C2-10 EXISTING SITE AND REMOVALS
- C3-10 SITE AND UTILITY PLAN
- C4-10 GRADING PLAN

PROJECT GENERAL NOTES

1. ALL WORK SHALL CONFORM TO THE CONTRACT DOCUMENTS, WHICH INCLUDE, BUT ARE NOT LIMITED TO, THE OWNER - CONTRACTOR AGREEMENT, THE PROJECT MANUAL (WHICH INCLUDES GENERAL SUPPLEMENTARY CONDITIONS AND SPECIFICATIONS), DRAWINGS OF ALL DISCIPLINES AND ALL ADDENDA, MODIFICATIONS, AND CLARIFICATIONS ISSUED BY ARCHITECT/ENGINEER.
2. CONTRACT DOCUMENTS SHALL BE ISSUED TO ALL SUBCONTRACTORS BY THE GENERAL CONTRACTOR IN COMPLETE SETS IN ORDER TO ACHIEVE THE FULL EXTENT AND COMPLETE COORDINATION OF ALL WORK.
3. WRITTEN DIMENSIONS TAKE PRECEDENCE OVER SCALED DIMENSIONS. NOTIFY ARCHITECT/ENGINEER OF ANY DISCREPANCIES OR CONDITIONS REQUIRING INFORMATION OR CLARIFICATION BEFORE PROCEEDING WITH THE WORK.
4. FIELD VERIFY ALL EXISTING CONDITIONS AND DIMENSIONS. NOTIFY ARCHITECT/ENGINEER OF ANY DISCREPANCIES OR CONDITIONS REQUIRING INFORMATION OR CLARIFICATION BEFORE PROCEEDING WITH THE WORK.
5. DETAILS SHOWN ARE INTENDED TO BE INDICATIVE OF THE PROFILES AND TYPE OF DETAILING REQUIRED THROUGHOUT THE WORK. DETAILS NOT SHOWN ARE SIMILAR IN CHARACTER TO DETAILS SHOWN. WHERE SPECIFIC DIMENSIONS, DETAILS, OR DESIGN INTENT CANNOT BE DETERMINED, NOTIFY ARCHITECT/ENGINEER BEFORE PROCEEDING WITH THE WORK.
6. ALL MANUFACTURED ARTICLES, MATERIALS, AND EQUIPMENT SHALL BE APPLIED, INSTALLED, CONNECTED, ERECTED, CLEANED, AND CONDITIONED ACCORDING TO MANUFACTURERS' INSTRUCTIONS. IN CASE OF DISCREPANCIES BETWEEN MANUFACTURERS' INSTRUCTIONS AND THE CONTRACT DOCUMENTS, NOTIFY ARCHITECT/ENGINEER BEFORE PROCEEDING WITH THE WORK.
7. ALL DISSIMILAR METALS SHALL BE EFFECTIVELY ISOLATED FROM EACH OTHER TO AVOID GALVANIC CORROSION.
8. THE LOCATION AND TYPE OF ALL EXISTING UTILITIES SHOWN ON THE PLANS ARE FOR GENERAL INFORMATION ONLY AND ARE ACCURATE AND COMPLETE TO THE BEST OF THE KNOWLEDGE OF I & S GROUP, INC. (ISG). NO WARRANTY OR GUARANTEE IS IMPLIED. THE CONTRACTOR SHALL VERIFY THE SIZES, LOCATIONS, AND ELEVATIONS OF ALL EXISTING UTILITIES PRIOR TO CONSTRUCTION. CONTRACTOR SHALL IMMEDIATELY NOTIFY ENGINEER OF ANY DISCREPANCIES OR VARIATIONS FROM PLAN.
9. THE CONTRACTOR IS TO CONTACT "DIGGERS HOTLINE" FOR UTILITY LOCATIONS A MINIMUM OF 3 BUSINESS DAYS PRIOR TO ANY EXCAVATION / CONSTRUCTION (811 OR 1-800-242-8511).



SHEET NOT VALID UNLESS THIS TEXT IS COLOR.
THIS DOCUMENT IS THE PROPERTY OF I & S GROUP, INC. AND MAY NOT BE USED, COPIED OR DUPLICATED WITHOUT PRIOR WRITTEN CONSENT.
© 2024 I & S GROUP, INC.

PROJECT
**BORTON
CONSTRUCTION
NEW OFFICE**

LA CROSSE WISCONSIN

REVISION SCHEDULE		
DATE	DESCRIPTION	BY

PROJECT NO.	26-34320
FILE NAME	34320 C0-GENERAL
DRAWN BY	AAE
DESIGNED BY	AAE
REVIEWED BY	KBR
ORIGINAL ISSUE DATE	06/05/2026
CLIENT PROJECT NO.	-

PROJECT INDEX:

OWNER:
BORTON CONSTRUCTION, INC.

PAUL BORSHEIM
2 COPELAND AVENUE + SUITE 201
LA CROSSE, WISCONSIN, 54603

PHONE: 608.779.0400
paulborsheim@bortonconstruction.com

PROJECT ADDRESS / LOCATION:

1325 ST ANDREW ST
LA CROSSE, WISCONSIN, 54603

MANAGING OFFICE:
I & S GROUP, INC. (ISG)

LA CROSSE OFFICE
201 MAIN STREET
SUITE 1020
LA CROSSE, WI 54601
PHONE: 608.789.2034

PROJECT MANAGER: KRIS ROPPE
EMAIL: Kristopher.Roppe@ISGinc.com



SPECIFICATIONS REFERENCE

ALL CONSTRUCTION SHALL COMPLY WITH THE CITY OF LA CROSSE STANDARD SPECIFICATIONS, CURRENT EDITION, WISDOT STANDARD SPECIFICATIONS, 2025 EDITION, WISDOT CONSTRUCTION AND MATERIALS MANUAL, CURRENT EDITION, WISCONSIN DEPARTMENT OF SAFETY AND PROFESSIONAL SERVICES STATE PLUMBING CODE, CURRENT EDITION, AND STANDARD SPECIFICATION FOR SEWER & WATER CONSTRUCTION IN WISCONSIN, 6th EDITION, UNLESS DIRECTED OTHERWISE.

PROJECT DATUM

HORIZONTAL COORDINATES HAVE BEEN REFERENCED TO THE NORTH AMERICAN DATUM OF 1983 (NAD83), 2011 ADJUSTMENT (NAD83(2011)) ON THE LA CROSSE COUNTY COORDINATE SYSTEM, IN U.S. SURVEY FEET.

B.M. ELEVATION=645.45
TINH NW CORNER OF
ST. ANDREWS AND WOOD STREET

TOPOGRAPHIC SURVEY

THIS PROJECT'S TOPOGRAPHIC SURVEY CONSISTS OF DATA COLLECTED IN MAY 2026 BY ISG.

TITLE
TITLE SHEET

SHEET
C0-00



SHEET NOT VALID UNLESS THIS TEXT IS COLOR.

THIS DOCUMENT IS THE PROPERTY OF I & S GROUP, INC. AND MAY NOT BE USED, COPIED OR DUPLICATED WITHOUT PRIOR WRITTEN CONSENT.
© 2024 I & S GROUP, INC.

PROJECT
**BORTON
CONSTRUCTION
NEW OFFICE**

LA CROSSE WISCONSIN

REVISION SCHEDULE		
DATE	DESCRIPTION	BY

PROJECT NO.	26-34320
FILE NAME	34320 CO-GENERAL
DRAWN BY	AAE
DESIGNED BY	AAE
REVIEWED BY	KBR
ORIGINAL ISSUE DATE	06/05/2026
CLIENT PROJECT NO.	-

TITLE
**LEGEND AND
NOTES**

SHEET
C0-01

SYMBOL LEGEND

EXISTING		PROPOSED
○ EX STM MH	STORM MANHOLE	●
□ EX CB	STORM CATCH BASIN	■
EX CO → >> ---	STORM CLEANOUT	→ >> ---
--- >> ---	STORM CULVERT	--- >> ---
□	DOWNSPOUT	○
○	ROOF DRAIN	○
○ EX SAN MH	SANITARY MANHOLE	●
EX CO → >> ---	SANITARY CLEANOUT	→ >> ---
LS	LIFT STATION	▶
▷	WATER REDUCER	▶
⋈	WATER VALVE	⋈
⊗	WATER VALVE MAHOLE	⊗
⊙	WATER CURB STOP	⊙
⊕	WATER SHUT-OFF	⊕
EX POST INDICATOR VALVE	POST INDICATOR VALVE	⊗
⊕	FIRE DEPARTMENT CONNECTION	⊕
⊙	WELL	⊙
EX MW	MONITORING WELL	⊙
⊕	LAWN SPRINKLER BOX	⊕
×	LAWN SPRINKLER HEAD	×
⊕	HYDRANT	⊕
EX YARD HYD	YARD HYDRANT	⊕
⊕	UTILITY POLE	⊕
⊕	LIGHT POLE	⊕
⊕	GROUND LIGHT	⊕
→	GUY WIRE	→
▭	TRANSFORMER	▭
EX HH	HANDHOLE	▭
EX ELEC MH	ELECTRIC MANHOLE	○
EM	ELECTRIC METER	EM
UV	UTILITY VAULT	UV
AC	AIR CONDITIONER	AC
GM	GAS METER	GM
GV	GAS VALVE	GV
SB-1	SOIL BORING	SB-1
FP	FLAG POLE	FP
MB	MAILBOX	MB
EX SIGNAL	TRAFFIC SIGNAL	⊕
S	SIGN	S
+	STREET SIGN	+
W	WHEEL STOP	W
RR	RAILROAD CROSSING SIGN	RR
⊕	POST	⊕
○	DECIDUOUS TREE	○
★	CONIFEROUS TREE	★
⊕	BUSH	⊕
⊕	TREE STUMP	⊕
⊕	WETLAND / MARSH	⊕
⊕	ROCK / BOULDER	⊕

NOTE:
CONTRACTOR SHALL FIELD VERIFY THE LOCATIONS OF ALL EXISTING UTILITIES.

LINETYPE LEGEND

EXISTING		PROPOSED
--- >> ---	STORM DRAIN	--- >> ---
--- > ---	SANITARY SEWER	--- > ---
--- > ---	SANITARY SEWER FORCEMAIN	--- > ---
--- ---	WATER MAIN	--- ---
--- G ---	GAS	--- G ---
--- OE ---	OVERHEAD ELECTRIC	--- OE ---
--- UE ---	UNDERGROUND ELECTRIC	--- UE ---
--- UT ---	UNDERGROUND TELEPHONE	--- UT ---
--- UTV ---	UNDERGROUND TV	--- UTV ---
--- OHL ---	OVERHEAD UTILITY	--- OHL ---
--- UTL ---	UNDERGROUND UTILITY	--- UTL ---
--- FBO ---	FIBER OPTIC	--- FBO ---
--- WET ---	WETLAND	--- WET ---
--- W ---	WATER EDGE	--- W ---
~> ~>	DITCH / SWALE	→ →
--- x --- x ---	FENCE LINE	--- x --- x ---
~ ~ ~ ~ ~	TREE LINE	~ ~ ~ ~ ~
---	PROPERTY / LOT LINE	---
---	RIGHT OF WAY LINE	---
--- Δ --- Δ ---	ACCESS CONTROL	--- Δ --- Δ ---
---	EASEMENT LINE	---

NOTE:
CONTRACTOR SHALL FIELD VERIFY THE LOCATIONS OF ALL EXISTING UTILITIES.

ABBREVIATIONS

ADA	AMERICANS WITH DISABILITIES ACT	GAL	GALLON	PP	POLYPROPYLENE
ADD	ADDENDUM	GALV	GALVANIZED	PSI	POUNDS PER SQUARE INCH
AFF	ABOVE FINISHED FLOOR	GC	GENERAL CONTRACTOR	PVC	POLYVINYL CHLORIDE
AGG	AGGREGATE	GD	GROUND	PVMT	PAVEMENT
APPROX	APPROXIMATE	GFE	ELEVATION	QTY	QUANTITY
ARCH	ARCHITECT, ARCHITECTURAL	GL	GUTTERLINE	R	RIM
ARCH	ARCHITECTURAL BASEMENT FLOOR	GPM	GALLONS PER MINUTE	RAD	RADIUS
BFE	ELEVATION	GV	GATE VALVE	RCP	REINFORCED CONCRETE PIPE
BIT	BITUMINOUS	HDPE	HIGH DENSITY POLYETHYLENE	RD	ROOF DRAIN
BLDG	BUILDING	HD	HEAVY DUTY	REBAR	REINFORCING BAR
BM	BENCHMARK	HH	HANDHOLE	REM	REMOVE
CAD	COMPUTER-AIDED DESIGN	HMA	HOT MIX ASPHALT	ROW	RIGHT OF WAY
CB	CATCH BASIN	HORIZ	HORIZONTAL	R/W	RIGHT OF WAY
CFS	CUBIC FEET PER SECOND	HR	HOUR	SAN	SANITARY
CF	CUBIC FOOT	HWL	HIGH WATER LEVEL	SCH	SCHEDULE
CI	CAST IRON	HWY	HIGHWAY	SF	SQUARE FOOT
CIP	CAST IRON PIPE CAST IN PLACE	HYD	HYDRANT	SPEC	SPECIFICATION
CIPC	CONCRETE	I	INVERT	SQ	SQUARE
CJ	CONTROL JOINT	ID	INSIDE DIAMETER	STA	STATION
CL	CENTERLINE	IN	INCH	STM	STORM
CMP	CORRUGATED METAL PIPE	INV	INVERT	SY	SQUARE YARD
CO	CLEANOUT	IP	IRON PIPE	T/C	TOP OF CURB
CONC	CONCRETE	IPS	IRON PIPE SIZE	TEL	TELEPHONE
CONST	CONSTRUCTION	J-BOX	JUNCTION BOX	TEMP	TEMPORARY
CONT	CONTINUOUS	JT	JOINT	THRU	THROUGH
CR	COUNTY ROAD	LF	LINEAR FEET	TNFH	TOP NUT OF FIRE HYDRANT
CY	CUBIC YARD	LIN	LINEAR	TRANS	TRANSFORMER
C&G	CURB AND GUTTER	LPS	LOW PRESSURE	TV	TELEVISION
DEMO	DEMOLITION	LS	LUMP SUM	T/W	TOP OF WALL
DI	DROP INTAKE	LSO	LOWEST	TYP	TYPICAL UTILITY
DIA	DIAMETER	MAX	MAXIMUM	UT	UNDERGROUND TELEPHONE
DIM	DIMENSION	MB	MAIL BOX	VCP	VITRIFIED CLAY PIPE
DS	DOWNSPOUT	MECH	MECHANICAL	W/O	WITHOUT
EA	EACH	MH	MANHOLE	WI	WITH
EG	EXISTING GROUND	MIN	MINIMUM	YD	YARD
ELEC	ELECTRICAL	MISC	MISCELLANEOUS	YR	YEAR
ELEV	ELEVATION	NO	NUMBER		
EOF	EMERGENCY OVERFLOW	NTS	NOT TO SCALE		
EQ	EQUAL	NWL	NORMAL WATER LEVEL		
EX	EXISTING	OC	ON CENTER		
FG	FINISHED GROUND	OCEW	ON CENTER EACH WAY		
FIG	FORM GRADE	OD	OUTSIDE DIAMETER		
FDC	FIRE DEPARTMENT CONNECTION	OH	OVERHEAD		
FDN	FOUNDATION	OHWL	ORDINARY HIGH WATER LEVEL		
FES	FLARED END SECTION	OHD	OVERHEAD DOOR		
FFE	FINISHED FLOOR ELEVATION	OZ	OUNCE		
FPM	FEET PER MINUTE	PCC	PORTLAND CEMENT CONCRETE		
FPS	FEET PER SECOND	PED	PEDESTAL		
FT	FOOT, FEET	PERF	PERFORATED		
FTG	FOOTING	PL	PROPERTY LINE		
GA	GAUGE				

NOTE:
CONTRACTOR SHALL FIELD VERIFY THE LOCATIONS OF ALL EXISTING UTILITIES.

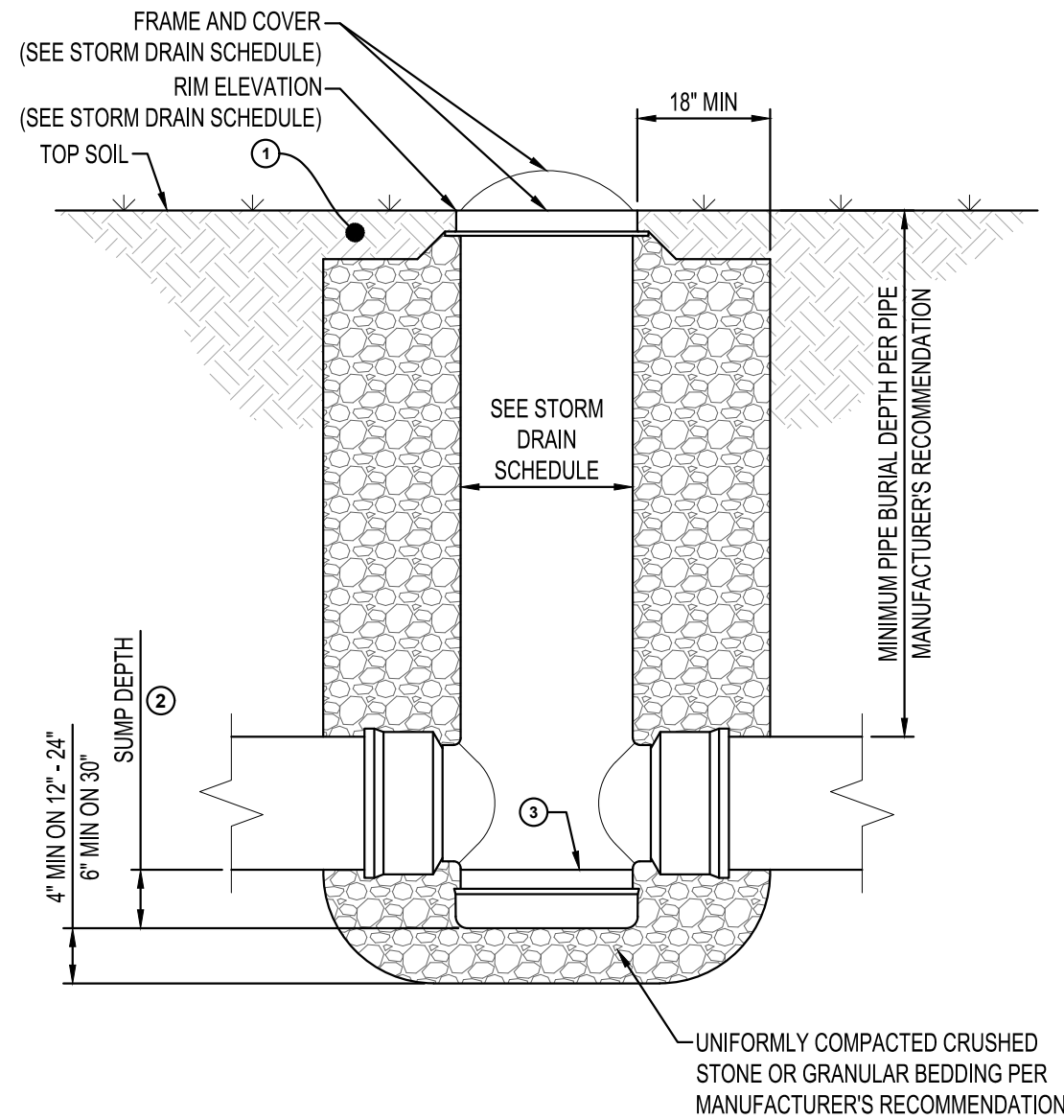

KEY NOTES:

- ① IF ASPHALT PAVEMENT, TOP OF CONCRETE COLLAR SHOULD BE SET AT BOTTOM OF NON-WEAR COURSE.
- ② 6" MIN ON 8" - 24" DRAIN BASIN, 10" MIN ON 30° DRAIN BASIN. VERIFY WITH MANUFACTURER'S RECOMMENDATIONS.
- ③ INVERT ELEVATION (SEE STORM DRAIN SCHEDULE)

DRAIN BASIN IN TURF
NTS SD320-U

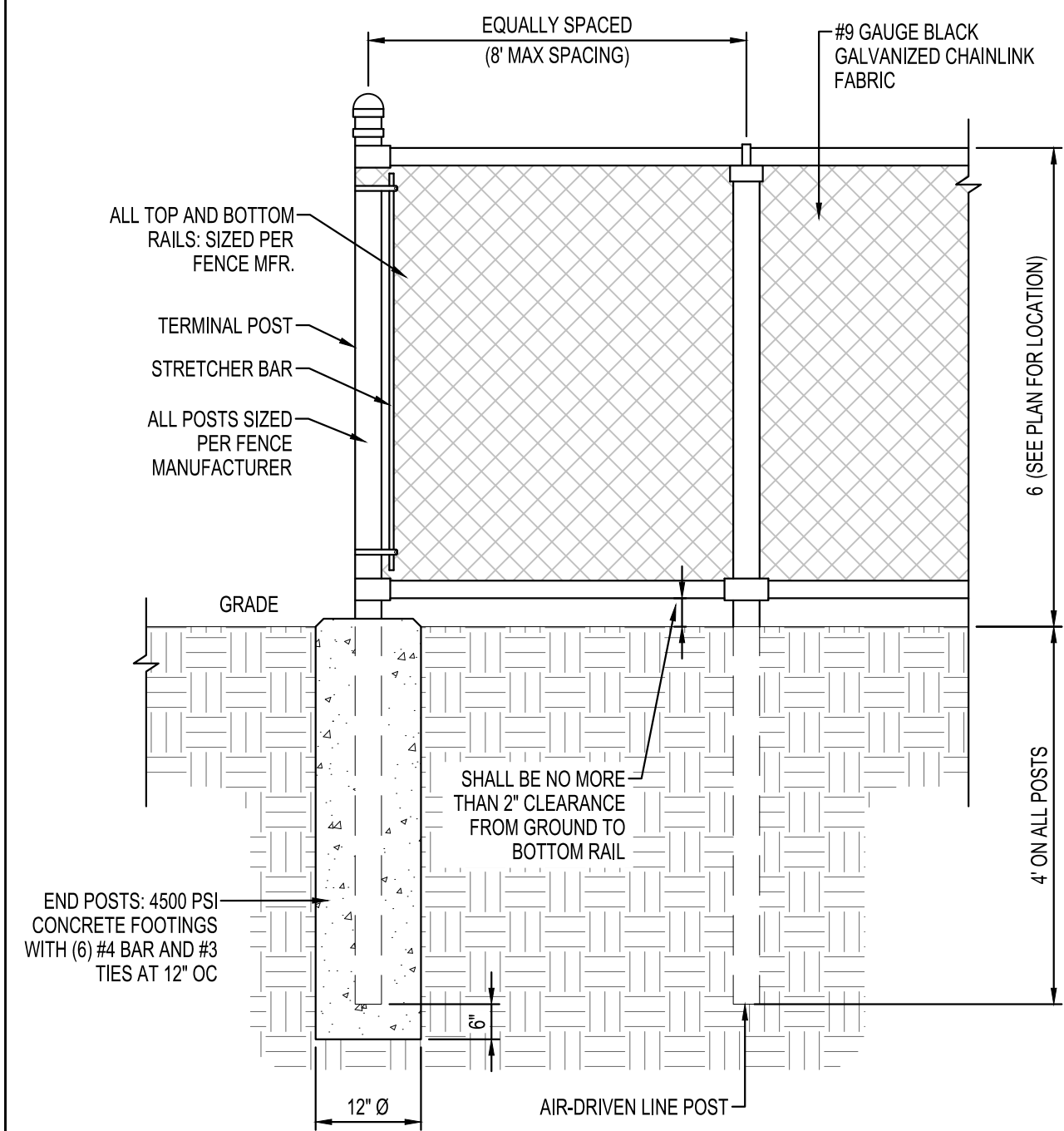

6' CHAINLINK FENCE
NTS AT600-U

NOTE:
1. VERIFY GATE OPENING WIDTH REQUIREMENT WITH MANUFACTURER

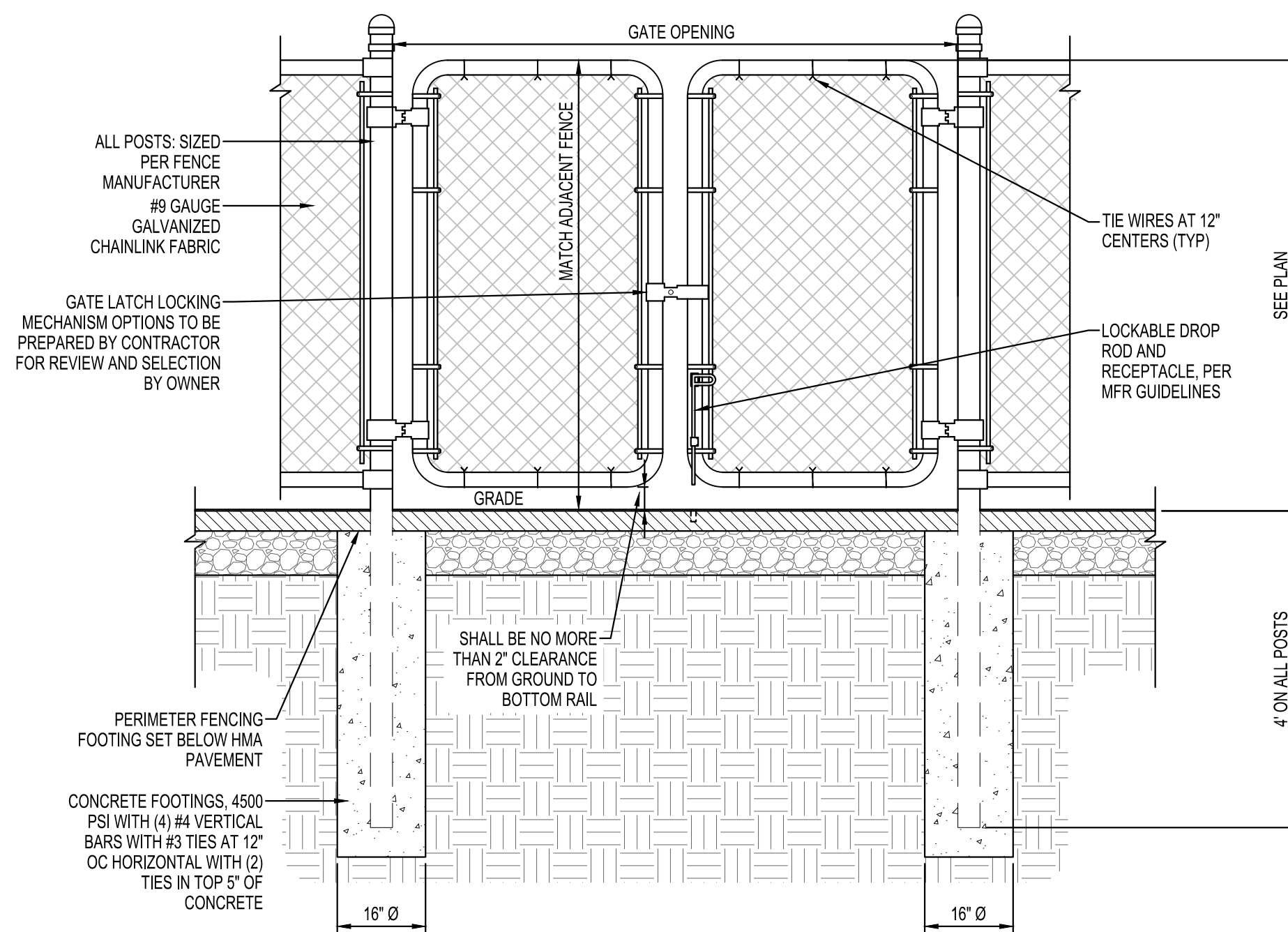

DOUBLE SWING GATE
NTS AT652-U

SHEET NOT VALID UNLESS THIS TEXT IS COLOR.

THIS DOCUMENT IS THE PROPERTY OF I & S GROUP, INC. AND MAY NOT BE USED, COPIED OR DUPLICATED WITHOUT PRIOR WRITTEN CONSENT.
© 2024 I & S GROUP, INC.

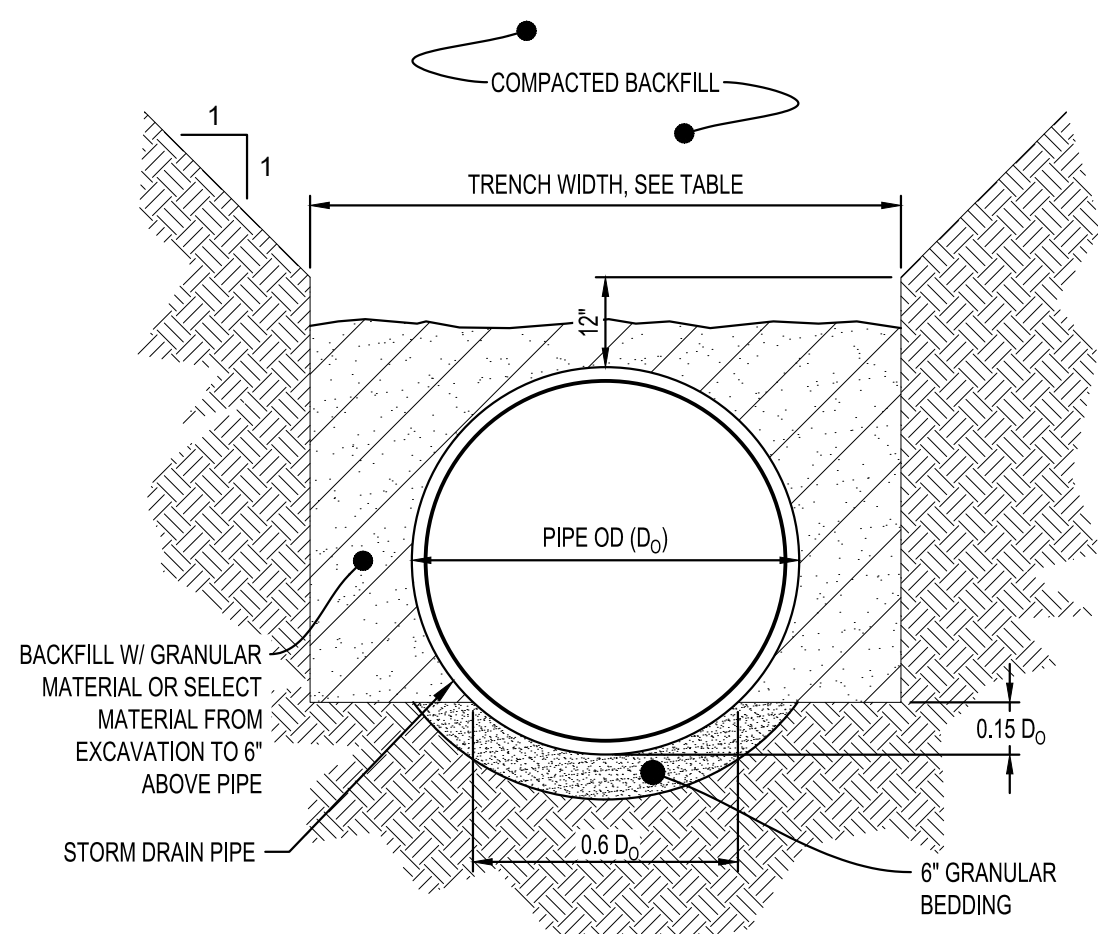

TRENCH WIDTH	
PIPE Ø	TRENCH WIDTH
36" OR LESS	D ₀ + 24"
42" TO 54"	1.5 x D ₀
60" OR OVER	D ₀ + 36"

NOTES:

- 1. GRANULAR BEDDING AND BACKFILL FOR STORM DRAIN PIPES SHALL BE INCIDENTAL TO STORM DRAIN CONSTRUCTION

NON-CONCRETE STORM DRAIN PIPE BEDDING
NTS SD600-MN

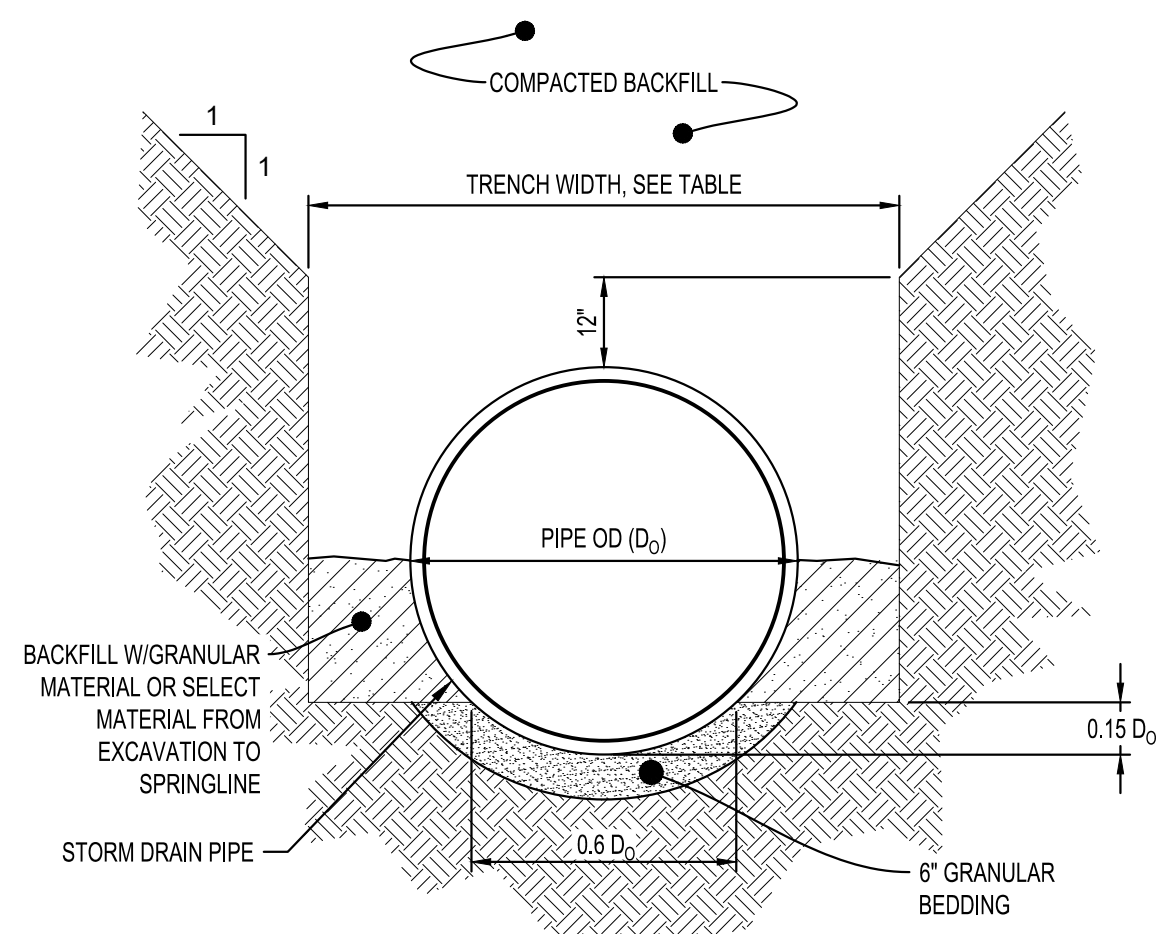

TRENCH WIDTH	
PIPE Ø	TRENCH WIDTH
36" OR LESS	D ₀ + 24"
42" TO 54"	1.5 x D ₀
60" OR OVER	D ₀ + 36"

NOTES:

- 1. GRANULAR BEDDING AND BACKFILL FOR STORM DRAIN PIPES SHALL BE INCIDENTAL TO STORM DRAIN CONSTRUCTION

REINFORCED CONCRETE STORM DRAIN PIPE BEDDING
NTS SD601-MN

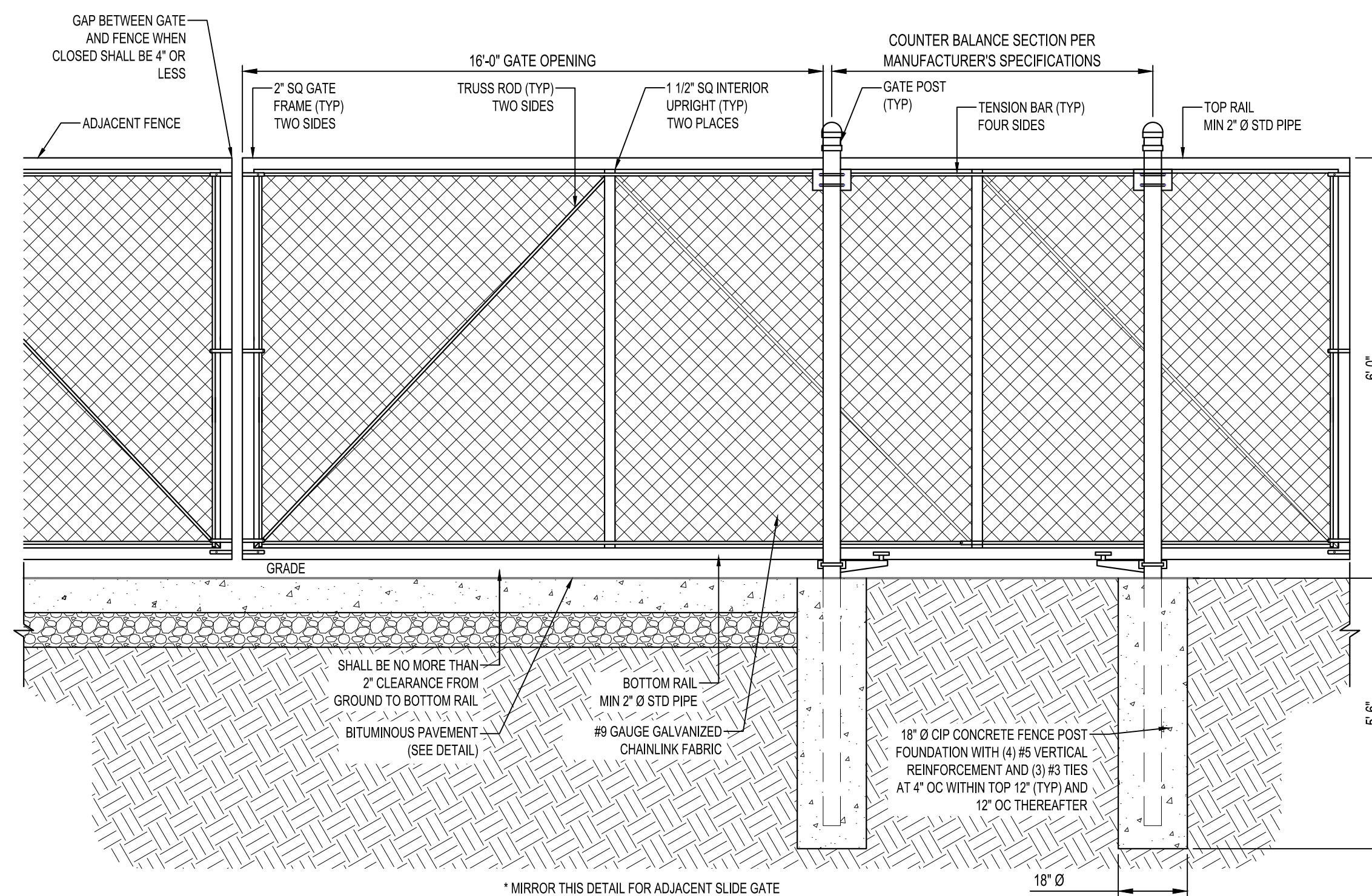

* MIRROR THIS DETAIL FOR ADJACENT SLIDE GATE
** REFER TO ELECTRICAL PLANS FOR GATE OPERATORS POWER AND CONTROLS.

16' MANUAL SLIDING GATE
NTS

BORTON CONSTRUCTION
NEW OFFICE

LA CROSSE WISCONSIN

REVISION SCHEDULE		
DATE	DESCRIPTION	BY

PROJECT NO.	26-34320
FILE NAME	34320 CO-DETAILS
DRAWN BY	AAE
DESIGNED BY	AAE
REVIEWED BY	KBR
ORIGINAL ISSUE DATE	06/05/2026
CLIENT PROJECT NO.	-

TYPICAL DETAILS

SHEET
C0-21



PREFORM - Industrial/Commercial

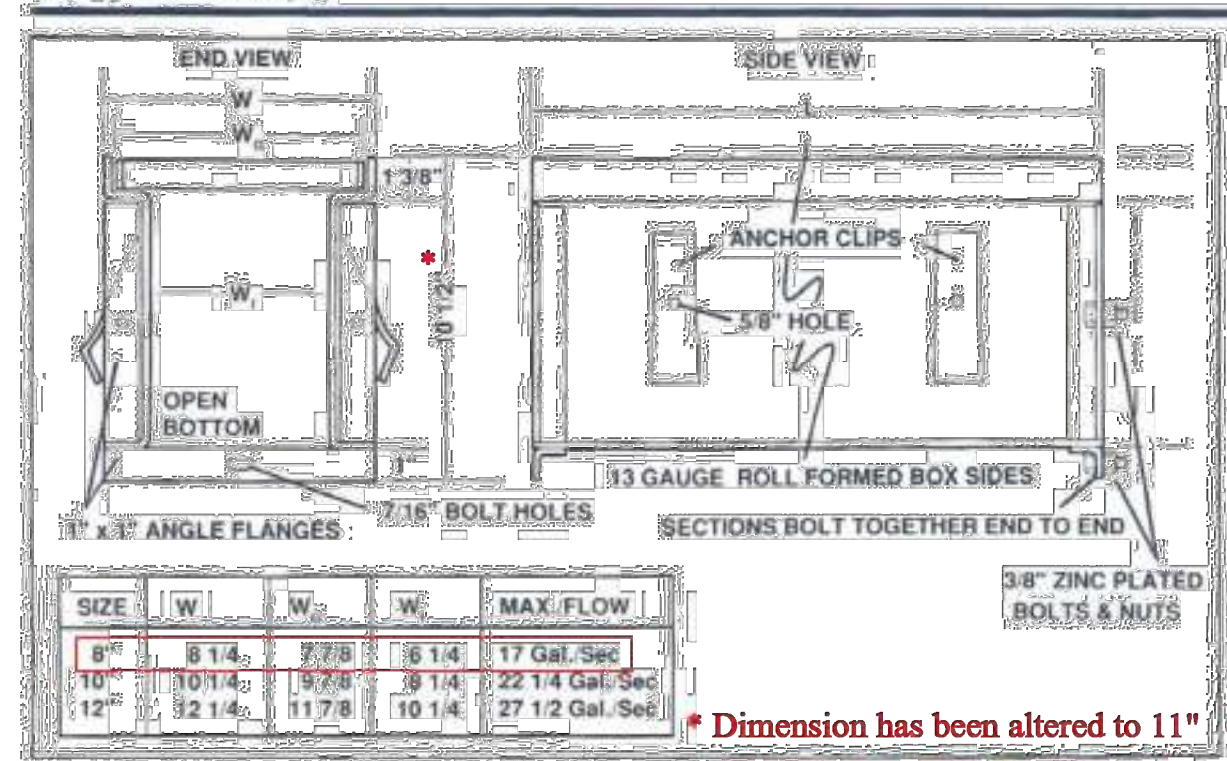

PREFORM RESIDENTIAL and Commercial

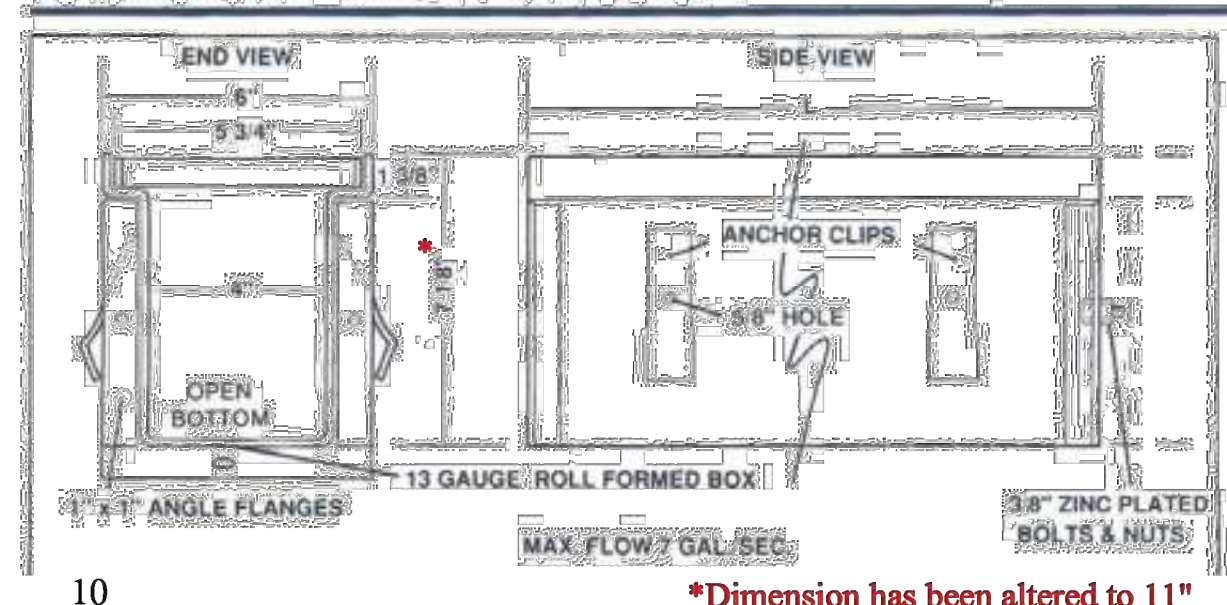

GRATES for DRAINAGE SYSTEMS

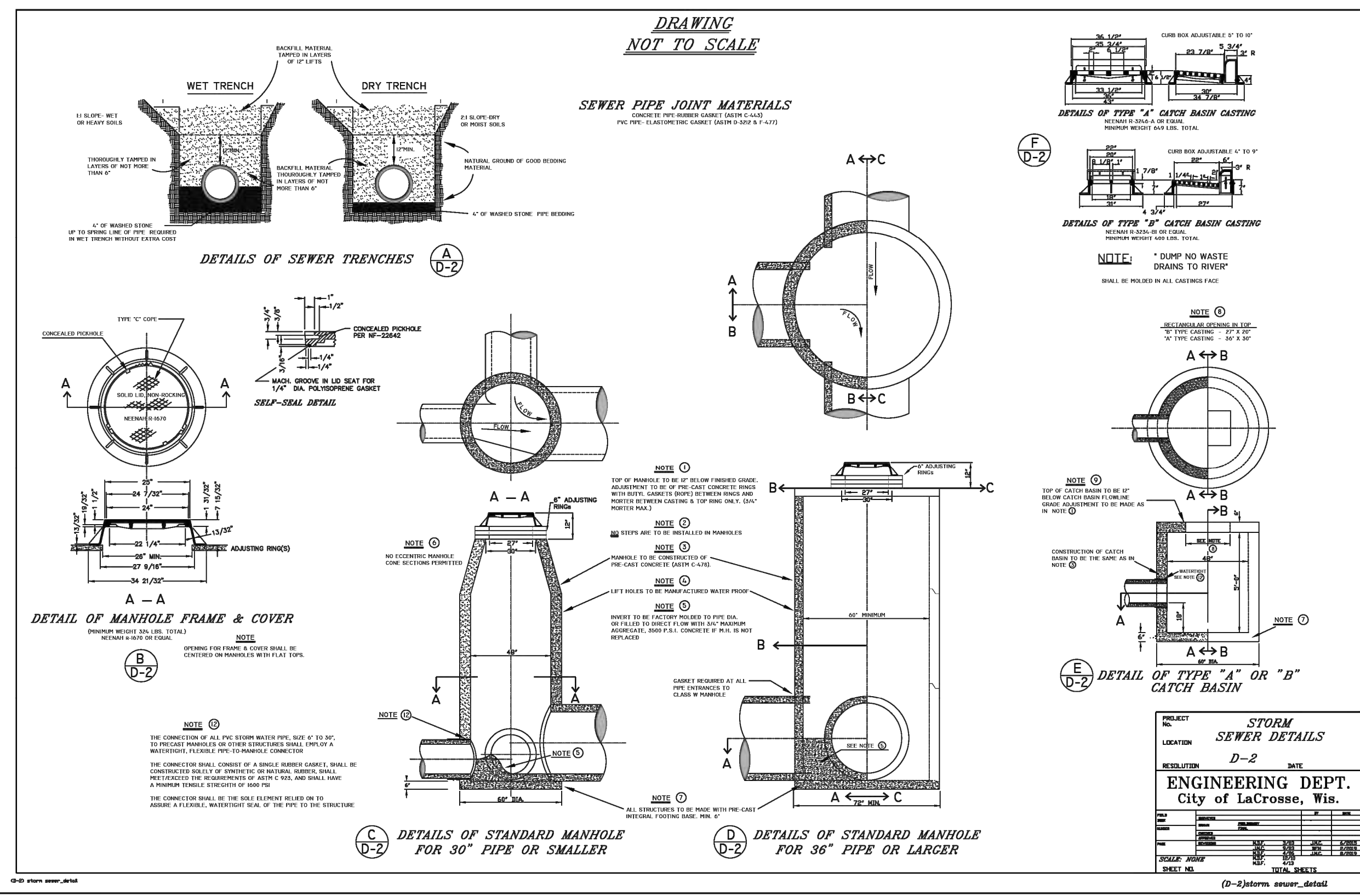
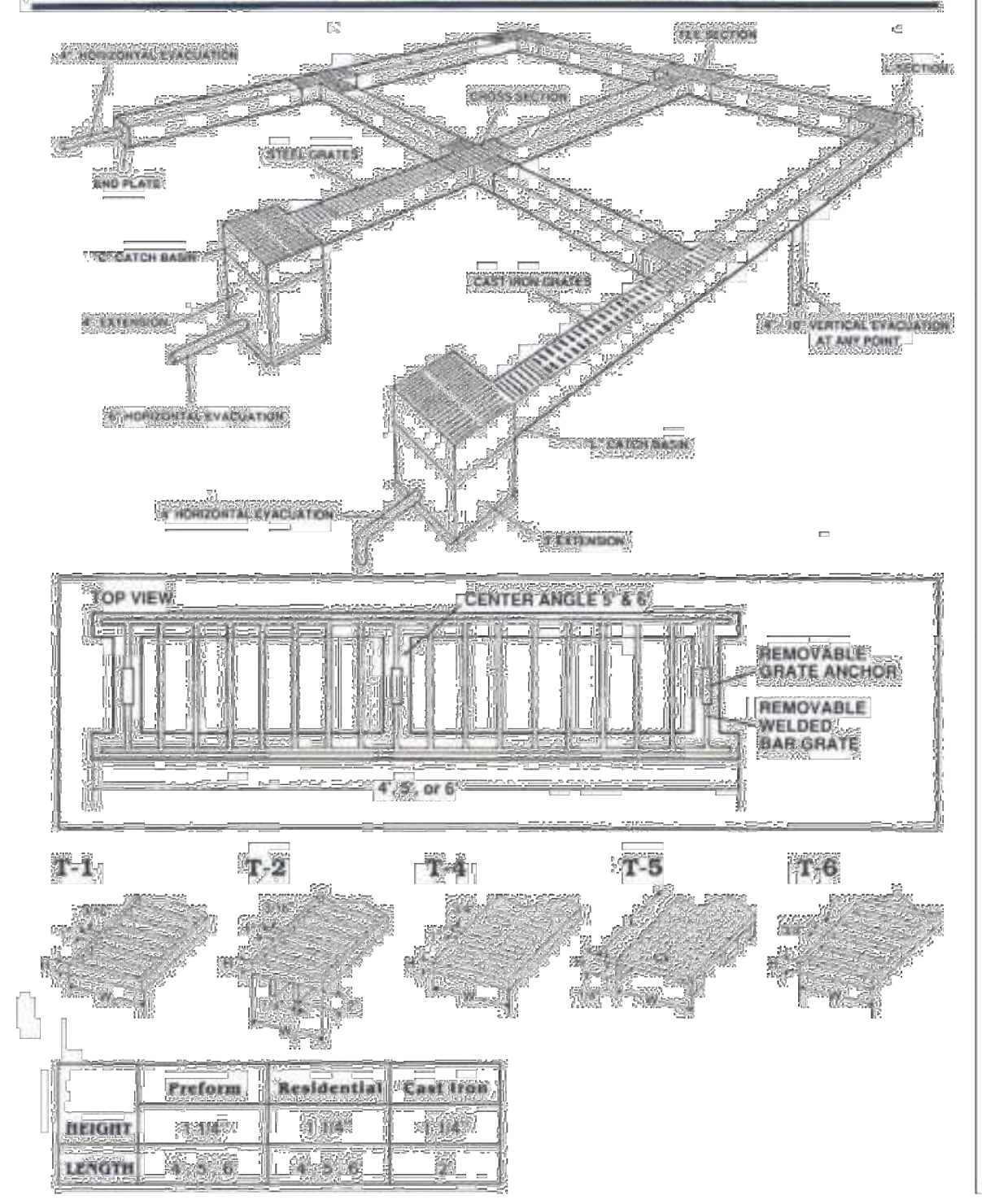

PIPE TRENCH

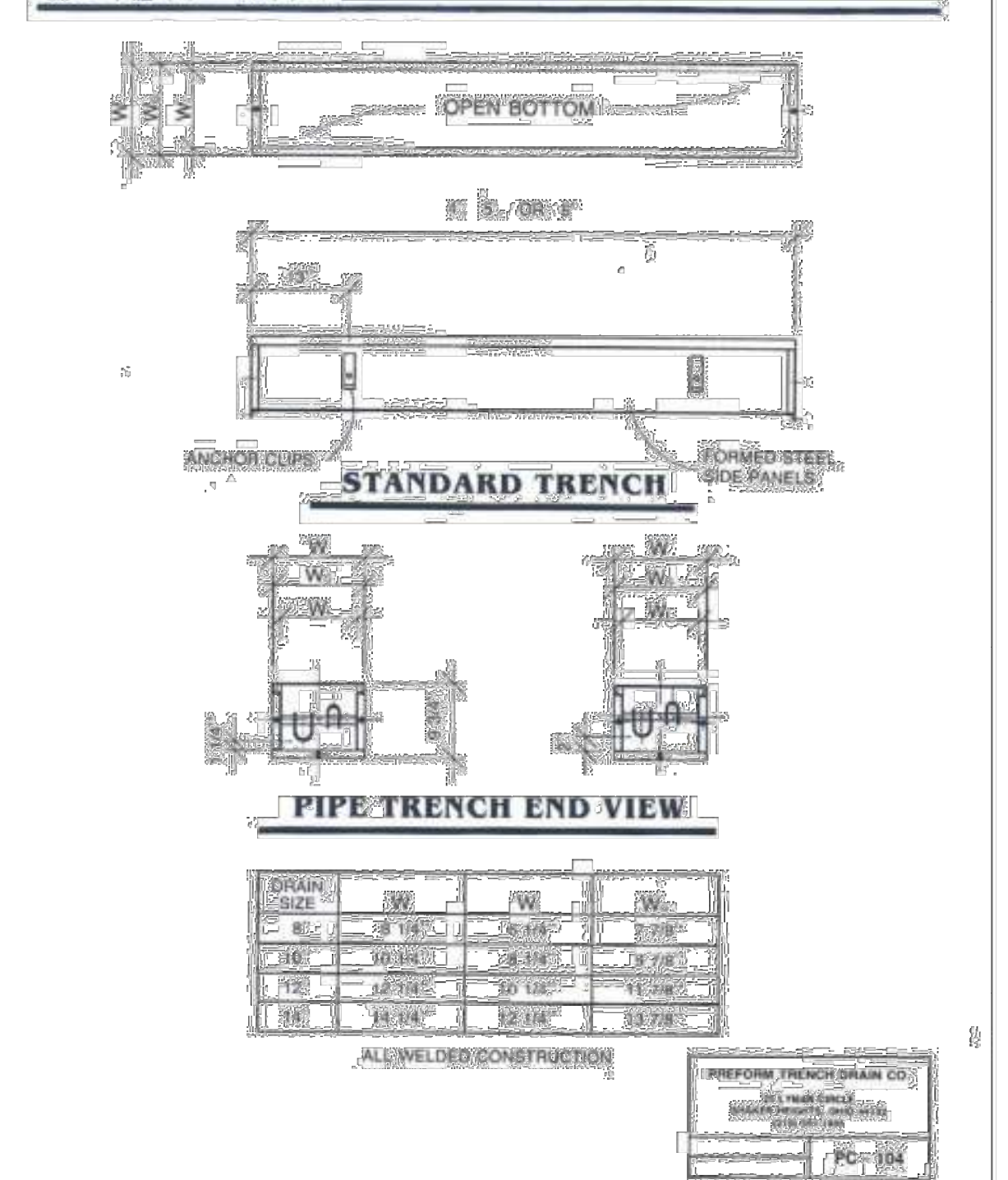

CATCH BASINS: INLET CONFIGURATIONS

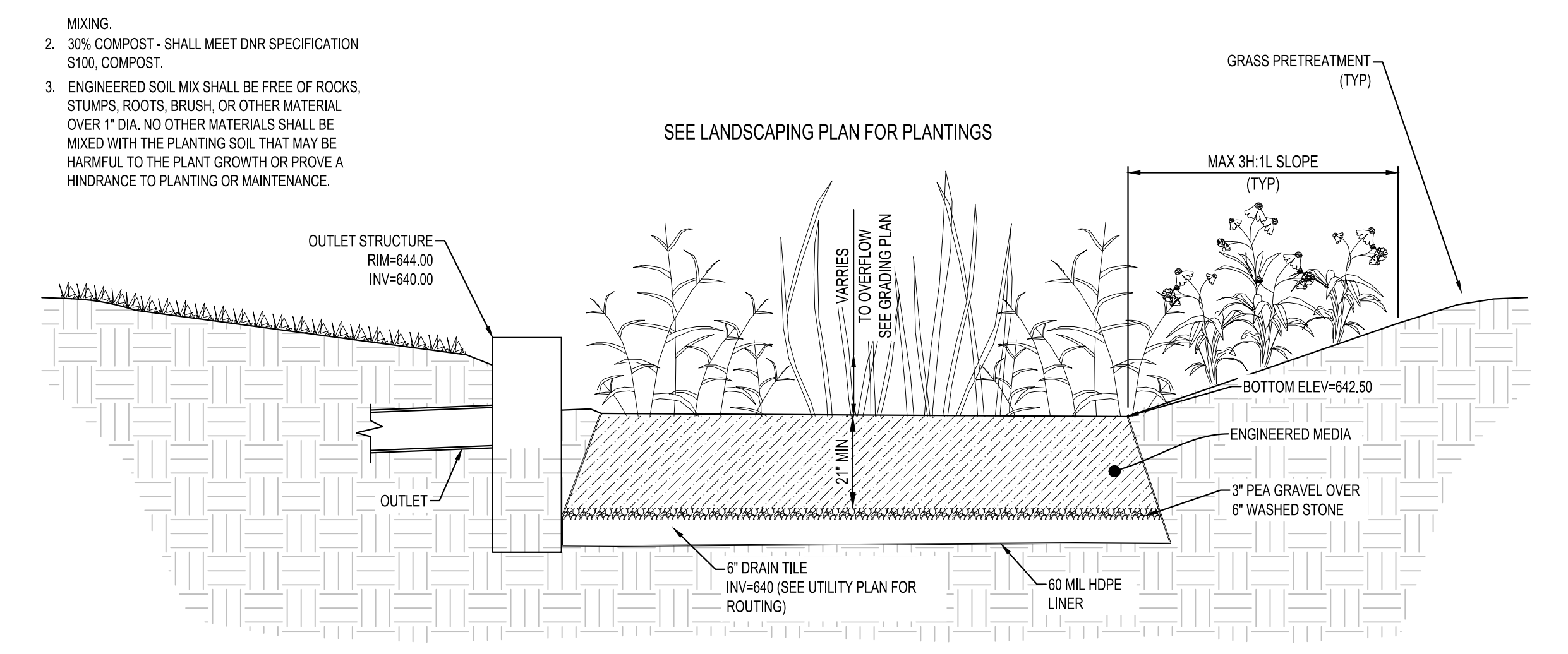
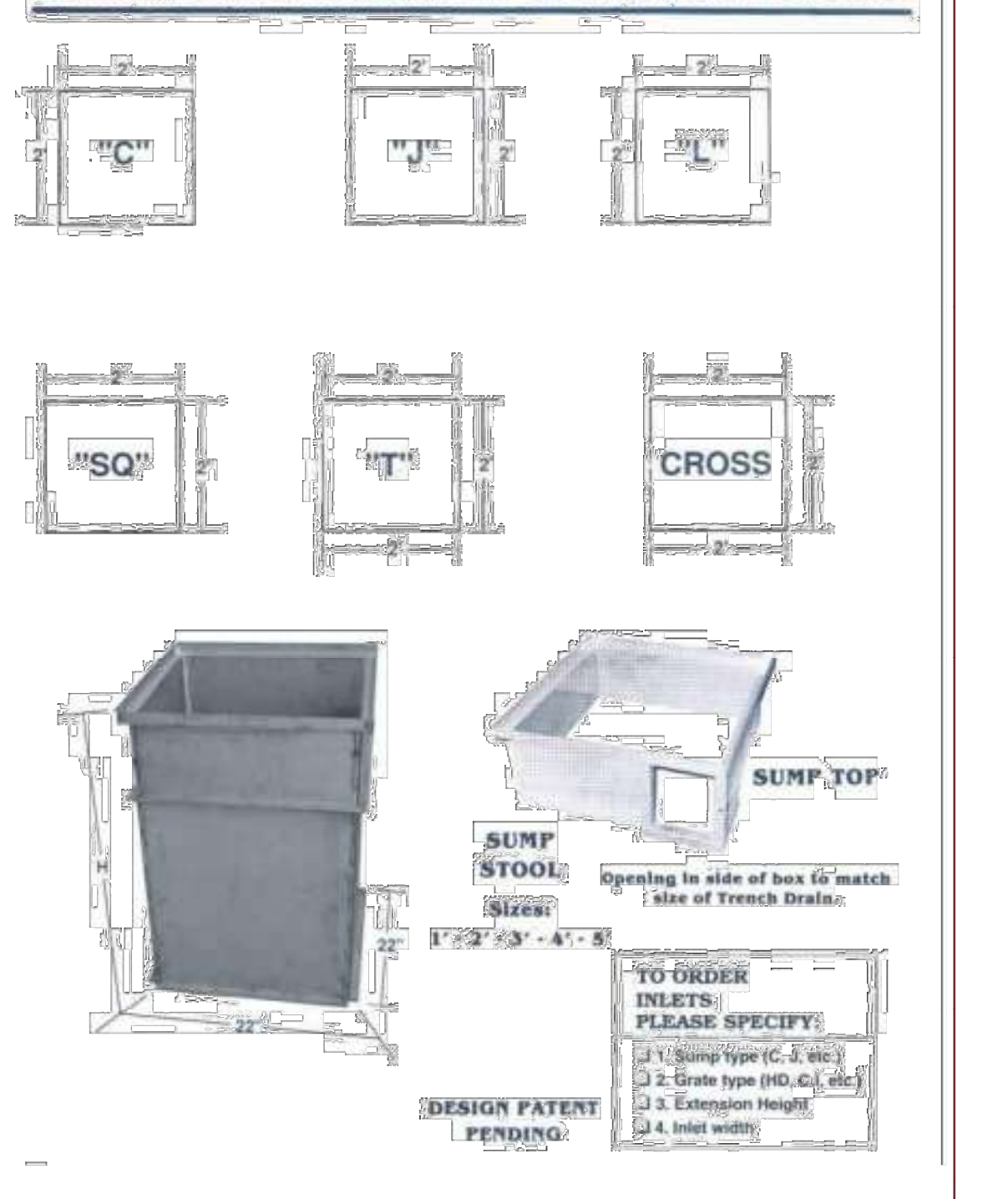

SHEET NOT VALID UNLESS THIS TEXT IS COLOR.

THIS DOCUMENT IS THE PROPERTY OF I & S GROUP, INC. AND MAY NOT BE USED, COPIED OR DUPLICATED WITHOUT PRIOR WRITTEN CONSENT. © 2024 I & S GROUP, INC.

PROJECT

BORTON CONSTRUCTION NEW OFFICE

LA CROSSE WISCONSIN

REVISION SCHEDULE		
DATE	DESCRIPTION	BY

PROJECT NO.	26-34320
FILE NAME	34320 CO-DETAILS
DRAWN BY	AAE
DESIGNED BY	AAE
REVIEWED BY	KBR
ORIGINAL ISSUE DATE	06/05/2026
CLIENT PROJECT NO.	-

TITLE

TYPICAL DETAILS

SHEET

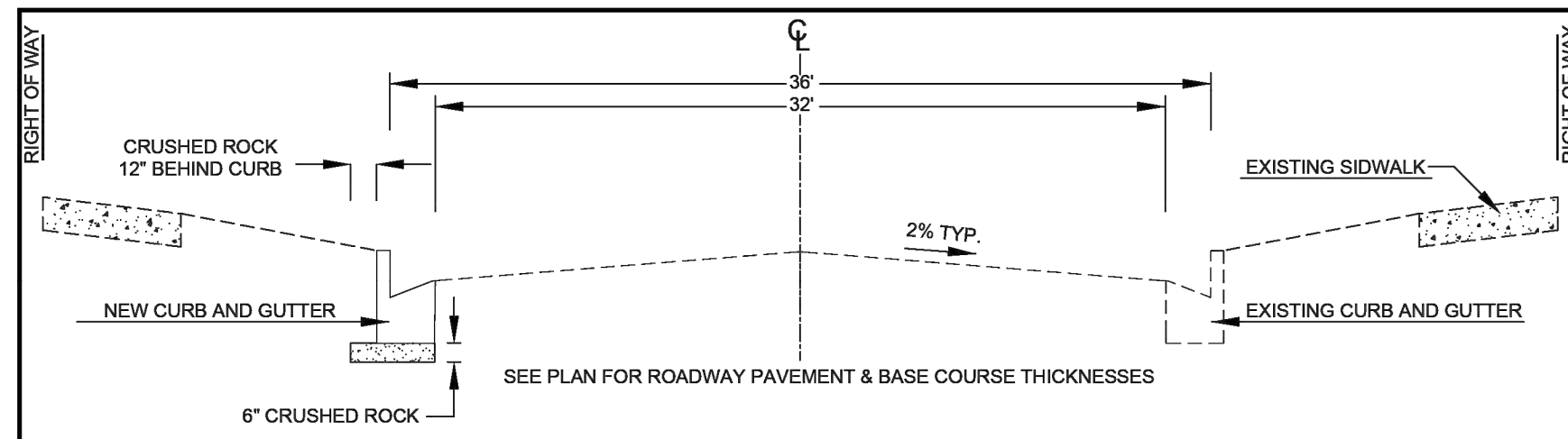

TYPICAL CROSS SECTION FOR 36' ROADWAY

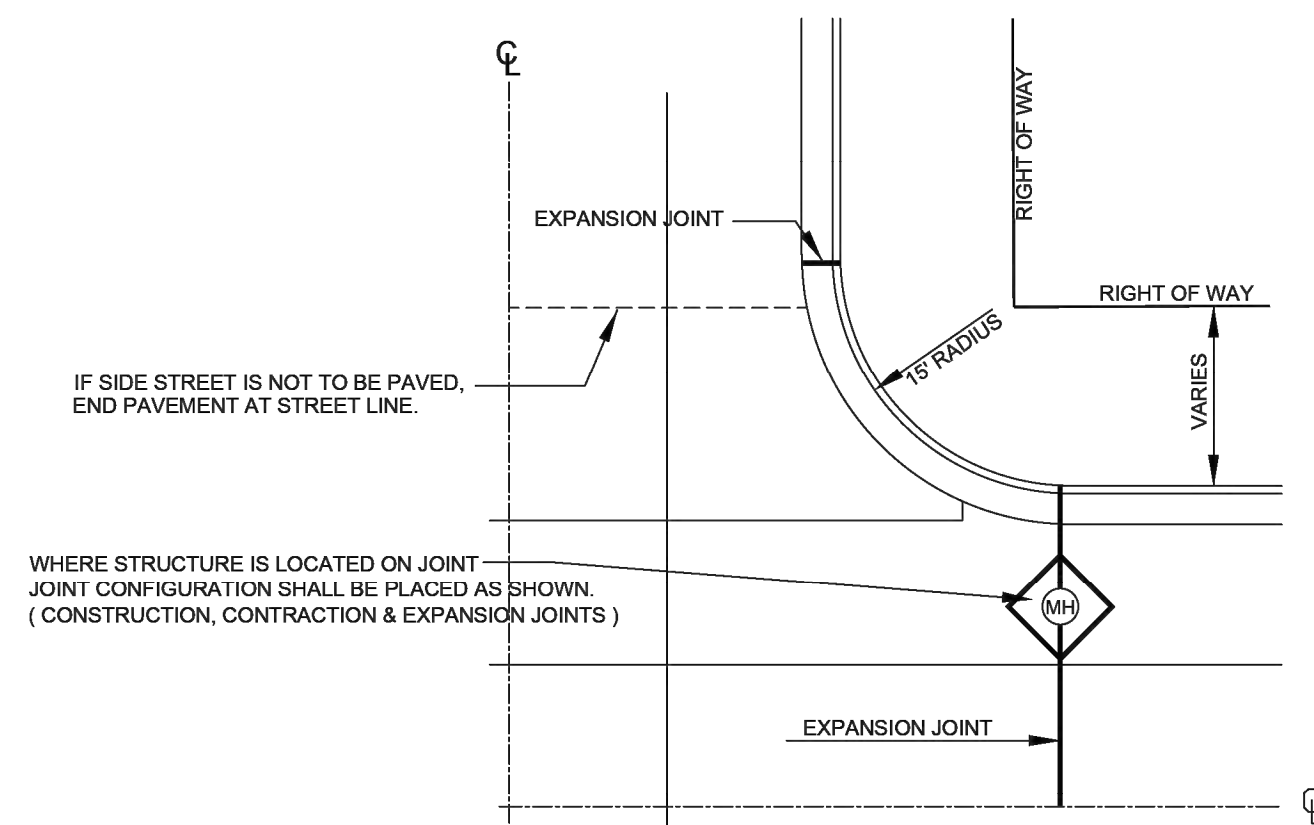

1/4 TYPICAL INTERSECTION

NOTES: JOINTS

1. EXPANSION JOINTS SHALL BE PLACED AT THE END OF RADII AT STREET INTERSECTIONS AND MID-BLOCK BETWEEN INTERSECTIONS. IN NO CASE SHALL THE DISTANCE BETWEEN EXPANSION JOINTS EXCEED 160 FEET.
2. THE DISTANCE BETWEEN TRANSVERSE JOINTS SHALL NOT BE LESS THAN 10 FEET AND SHALL BE TYPICALLY 20 FEET APART.
3. LONGITUDINAL CONSTRUCTION JOINTS BETWEEN CURB AND GUTTER SECTION AND CONC. PAVING SECTION SHALL BE SEALED AS SHOWN ON JOINT DETAILS.

CONCRETE PAVEMENT JOINT DETAILS

CONTRACTION

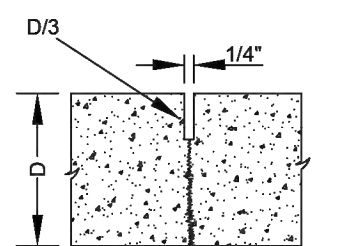

TOOLED / SAWED

CONSTRUCTION

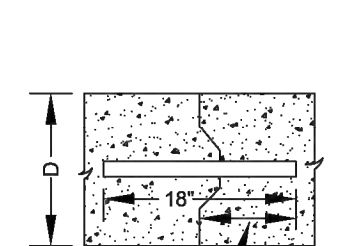

Doweled & Keyed Transverse

EXPANSION

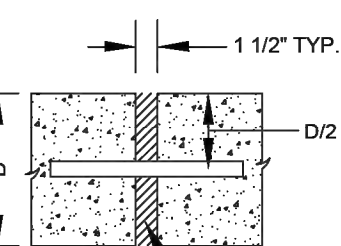

Doweled Transverse

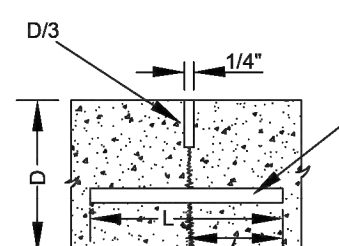

Tied Longitudinal

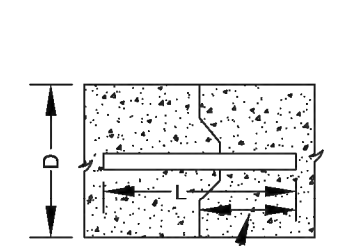

Tied & Keyed Longitudinal

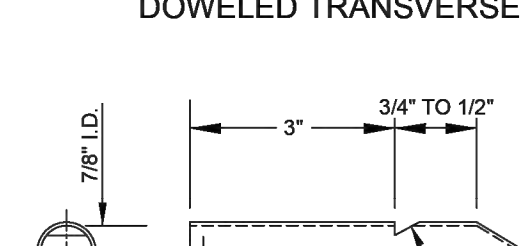

Dowel Socket Detail

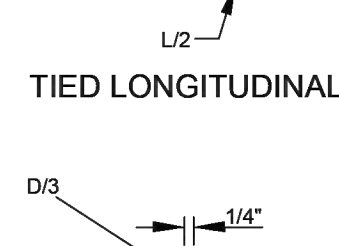

Doweled Transverse

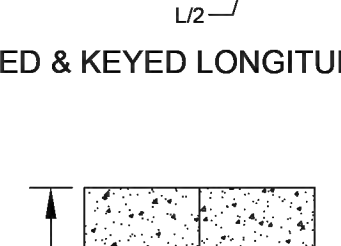

Tied Longitudinal

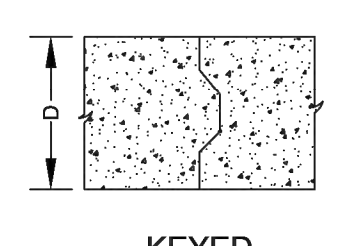

Keyed

ALL JOINTS TO BE SEALED TO KEEP OUT FOREIGN DEBRIS

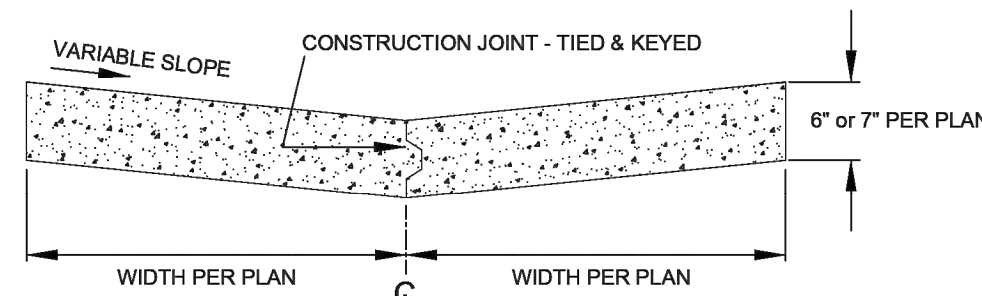

TYPICAL ALLEY PAVEMENT SECTION DETAIL

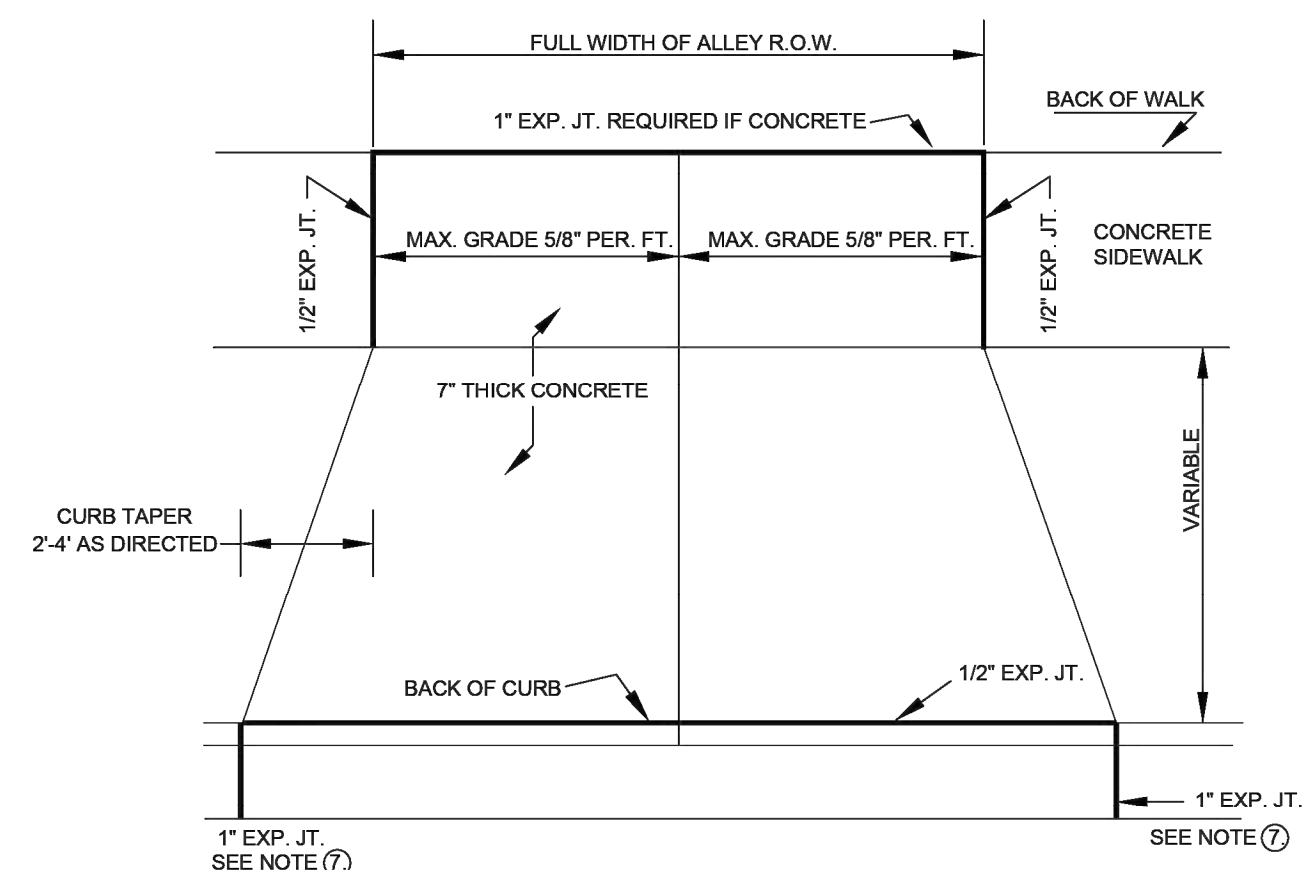

STANDARD ALLEY DRIVEWAY DETAIL

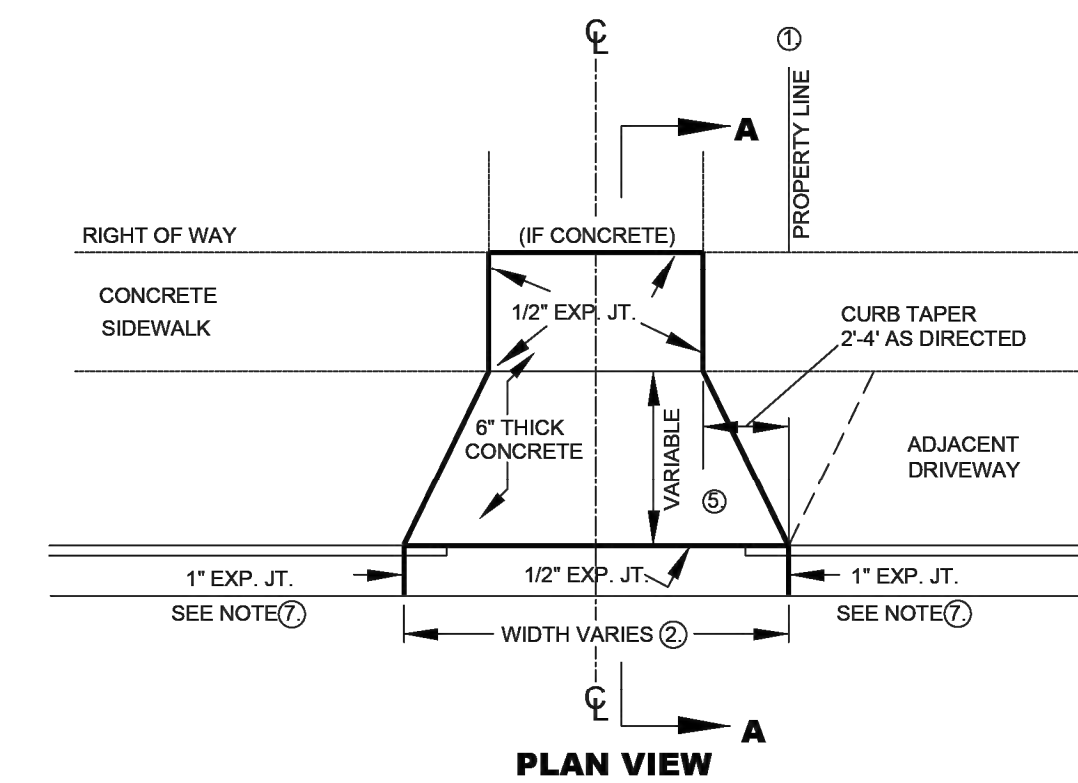

PLAN VIEW

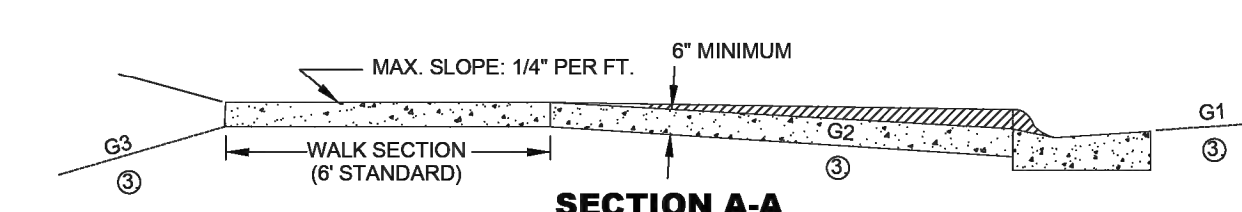

**SECTION A-A
STANDARD DRIVEWAY DETAIL**

1. DRIVE SECTION SHALL NOT OVERLAP PROPERTY LINE EXTENDED, EXCEPT WHERE PERMITTED BY THE ENGINEER, OR WHEN A JOINT DRIVEWAY AGREEMENT IS EXECUTED BY OWNERS OF ADJACENT PROPERTIES.
2. MAXIMUM DRIVEWAY WIDTH AT THE CURB AND SIDEWALK IS SET FORTH IN CITY ORDINANCE SEC. 40-4. FINAL DIMENSIONS SHALL BE APPROVED BY THE ENGINEERING DEPARTMENT.
3. THE BREAKOVER ANGLE (CAUSE OF CARS BOTTOMING) BECOMES CRITICAL WHEN THE ALGEBRAIC DIFFERENCE OF GRADES (G1, G2, & G3) EXCEEDS 11%.
4. A REINFORCED DRIVE SECTION IS REQUIRED FOR CURB & GUTTER IN AREAS ZONED INDUSTRIAL OR COMMERCIAL.
5. BACK OF CURB TO FRONT OF CONCRETE SIDEWALK MUST BE CONCRETE, BRICK OR ASPHALT.
6. MECHANICAL COMPACTION OF SUBSOIL IN LAYERS LESS THAN 12" TO ACHIEVE MINIMUM COMPACTION OF 95% OF MAXIMUM DENSITY FROM MODIFIED PROCTOR IS REQUIRED. (INCLUDING STREET SIDE AFTER FORMS ARE REMOVED)
7. EXPANSION JOINT IS REQUIRED AT BOTH ENDS OF DRIVEWAY WHEN ONLY DRIVEWAY IS INSTALLED OR REPLACED. WHEN ENTIRE BLOCK OF CURB & GUTTER IS INSTALLED THE EXPANSION JOINT AT DRIVEWAY ENDS MAY BE OMITTED.
8. TURNING OF 2" DIAMETER DRIVEWAY RETURNS IN LIEU OF DIMINISHING CURB AS SHOWN IS PERMITTED IF DESIRED BY PROPERTY OWNER.
9. INSTALLATION OF A DRIVEWAY BY REMOVING EXISTING CURB ONLY IS NOT ALLOWED. ENTIRE EXISTING C&G MUST BE REMOVED FOR NEW DRIVEWAYS. SAWING & REMOVAL OF A MINIMUM 2' WIDTH OF ASPHALT STREET PAVEMENT TO INSTALL FRONT FORMS IS REQUIRED.

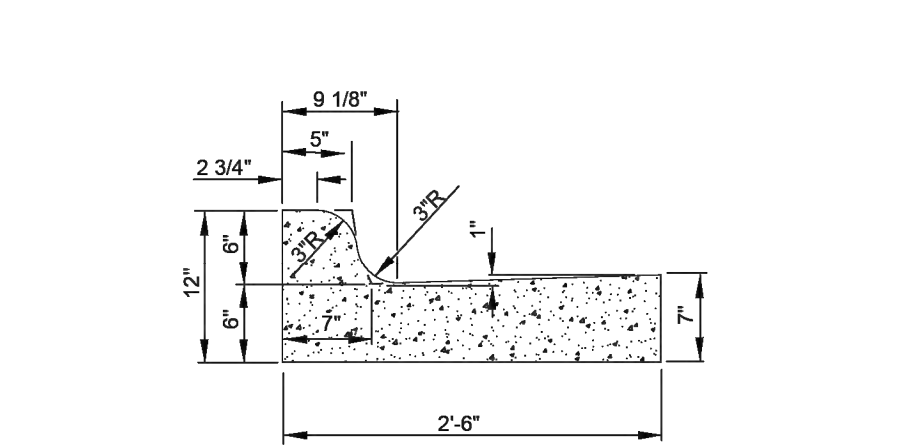

STANDARD CURB & GUTTER SECTION

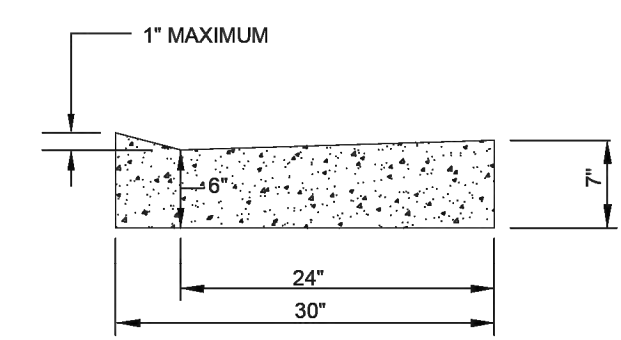

GUTTER ONLY SECTION

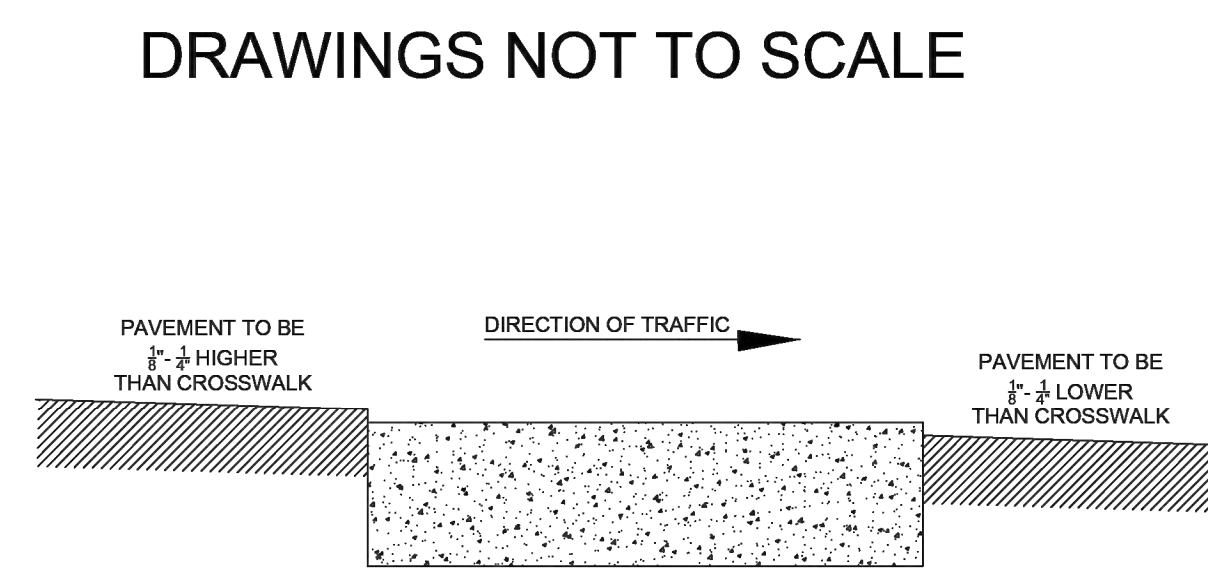

CONCRETE CROSSWALK DETAIL

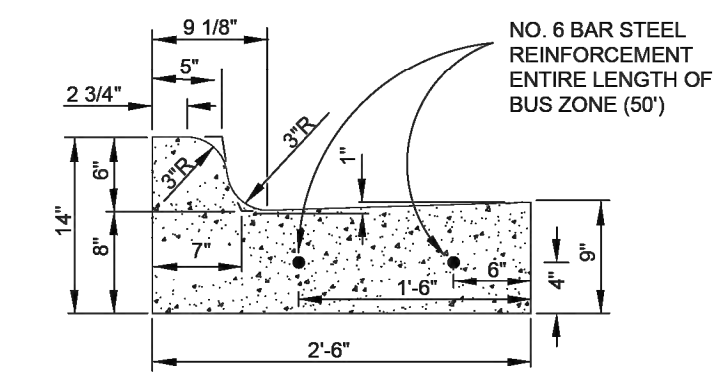

REINFORCED CURB & GUTTER SECTION (BUS STOP LOCATIONS)

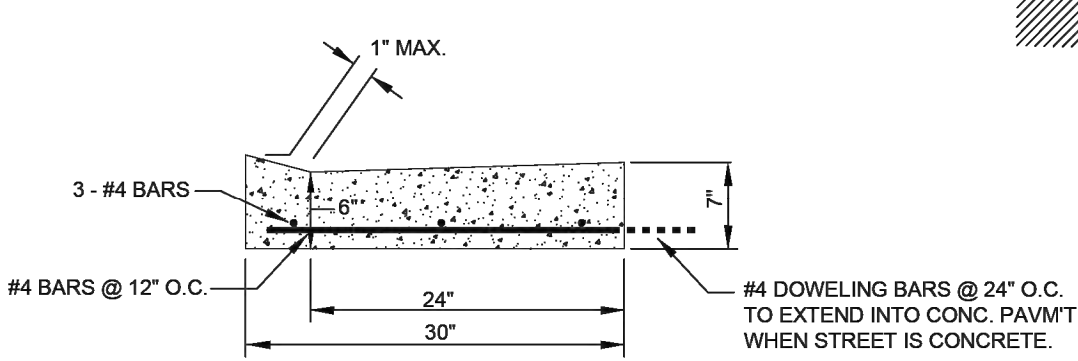

REINFORCED DRIVEWAY SECTION

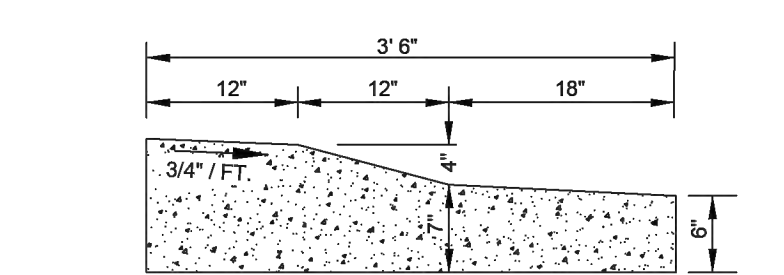

TRAFFIC CIRCLE CURB SECTION

DRAWINGS NOT TO SCALE

**STANDARD DETAIL D-1-1
CONCRETE PAVEMENT & CURB AND GUTTER**

ENGINEERING DEPT.
City of LaCrosse, Wis.

FIELD NO.	DATE	BY	DATE
DESIGNED			
CHECKED			
APPROVED			
REVIEWED			

SCALE: NONE

SHEET NOT VALID UNLESS THIS TEXT IS COLOR.

THIS DOCUMENT IS THE PROPERTY OF I & S GROUP, INC. AND MAY NOT BE USED, COPIED OR DUPLICATED WITHOUT PRIOR WRITTEN CONSENT.
© 2024 I & S GROUP, INC.

PROJECT
**BORTON CONSTRUCTION
NEW OFFICE**

LA CROSSE WISCONSIN

REVISION SCHEDULE		
DATE	DESCRIPTION	BY

PROJECT NO. 26-34320
FILE NAME 34320 CO-DETAILS
DRAWN BY AAE
DESIGNED BY AAE
REVIEWED BY KBR
ORIGINAL ISSUE DATE 06/05/2026
CLIENT PROJECT NO. -

TITLE
TYPICAL DETAILS

SHEET
C0-23

EROSION CONTROL NOTES

PROJECT LOCATION

PROJECT LOCATION:
CITY/TOWNSHIP:
COUNTY/STATE:
ZIP CODE:
LATITUDE/LONGITUDE:

PROJECT DESCRIPTION

THE PROJECT INCLUDES CONSTRUCTION OF AN APARTMENT BUILDING, CONCRETE PAVEMENT, ASPHALT PAVEMENT, CURB & GUTTER, AND CONCRETE WALK, ALONG WITH ALL THE NECESSARY GRADING, UTILITIES, STORM WATER MANAGEMENT, EROSION CONTROL, AND ANY ADDITIONAL COMPONENTS.

TENTATIVE CONSTRUCTION SCHEDULE (OPERATOR SHOULD PROVIDE ESTIMATED CONSTRUCTION SCHEDULE TO THE OWNER'S REPRESENTATIVE)	
CONSTRUCTION ACTIVITIES:	ESTIMATED DATES OF SOIL DISTURBANCE ACTIVITIES:
CLEARING AND GRUBBING OPERATIONS, GRADING, BASIN EXCAVATION	APRIL – JUNE 2024
BASIN SEEDING	JUNE 2024
BRIDGE	APRIL – OCTOBER 2024
CULVERT REMOVAL AND REPLACEMENT	JUNE – AUGUST 2024
CURB & GUTTER/SIDEWALK	AUGUST – OCTOBER 2024
PAVING	SEPTEMBER – OCTOBER 2024
INITIAL TURF, BRIDGE RAILING/LIGHTING	NOVEMBER 2024
LANDSCAPING, FINAL TURF, MISC.	APRIL – AUGUST 2024

PRE-CONSTRUCTION IMPERVIOUS SURFACE AND DISTURBED AREA CALCULATIONS

TOTAL AREA TO BE DISTURBED = XXXX ACRES
MINIMUM AREA REQUIREING WPDES PERMIT = 1.00 ACRES
****PROJECT DOES NOT REQUIRE A WPDES PERMIT****
IMPERVIOUS AREA: PRE-CONSTRUCTION = X.XX ACRES/POST-CONSTRUCTION = X.XX ACRES
NET INCREASE OF IMPERVIOUS AREA = X.XX ACRES (AREAS EXCLUDES 0.525 ACRES MILL & OVERLAY ON EXCELSIOR BLVD.)

CONTACT INFORMATION/RESPONSIBLE PARTIES

THE OWNER OWNS THE LAND, ADJACENT ROADS, AND EASEMENT AREAS ASSOCIATED WITH THE PROJECT. THE OWNER IS THE OWNER CO-PERMITTEE APPLYING FOR PERMIT COVERAGE AND WILL BE RESPONSIBLE FOR COMPLIANCE WITH ALL TERMS AND CONDITIONS OF THE PERMIT INCLUDING DEVELOPING THIS EROSION CONTROL PLAN AND THE LONG-TERM MAINTENANCE PLAN OF THE PERMANENT STORMWATER MANAGEMENT SYSTEM FOR THIS PROJECT (IF APPLICABLE). THE OWNER WILL ENSURE THAT THE DESCRIBED WORK IN THE EROSION CONTROL PLAN IS BEING COMPLETED BY THE OPERATOR PERMITTEE.

OWNER/PERMITTEE: COMPANY (CONTACT NAME, TITLE)
ADDRESS
CITY, STATE ZIP
000.000.0000/EMAIL

THE PRIMARY CONTRACTOR WILL ENTER INTO A CONTRACT WITH THE OWNER TO COMPLETE THE REQUIRED WORK FOR THIS PROJECT. THE PRIMARY CONTRACTOR WILL BECOME (UNDER CONTRACT) THE OPERATOR CO-PERMITTEE APPLYING FOR PERMIT COVERAGE ON THE WPDES, AND THEREBY AGREE TO IMPLEMENT THIS EROSION CONTROL PLAN IN COOPERATION WITH THE OWNER. THE OPERATOR IS RESPONSIBLE FOR IDENTIFYING AN EROSION CONTROL SUPERVISOR PRIOR TO STARTING CONSTRUCTION (REFER TO EROSION CONTROL AMENDMENT SECTION).

THE OPERATOR WILL ENSURE THAT INDIVIDUALS OVERSEEING OR IMPLEMENTING THE EROSION CONTROL PLAN HAVE BEEN PROPERLY TRAINED AND THAT CERTIFICATIONS WILL BE MADE AVAILABLE UPON REQUEST. THIS INCLUDES ANY SUB-CONTRACTORS THAT THE OPERATOR EMPLOYS UNDER SEPARATE CONTRACT. THE OPERATOR WILL PROVIDE THE CONTACT INFORMATION FOR THE EROSION CONTROL SUPERVISOR, SITE SUPERINTENDENT/FOREMAN, AND BMP INSTALLERS. THE EROSION CONTROL SUPERVISOR SHALL BE A RESPONSIBLE EMPLOYEE OF THE PRIME CONTRACTOR AND/OR DULY AUTHORIZED BY THE PRIME CONTRACTOR TO REPRESENT THE PRIME CONTRACTOR ON ALL MATTERS PERTAINING TO THE WORK. CONSTRUCTION STORMWATER PERMIT COMPLIANCE. THE EROSION CONTROL SUPERVISOR SHALL HAVE AUTHORITY OVER ALL OPERATOR ACTIVITIES WHICH INFLUENCE WPDES PERMIT COMPLIANCE, INCLUDING GRADING, EXCAVATION, BRIDGE CONSTRUCTION, CULVERT INSTALLATION, UTILITY WORK, CLEARING/GRUBBING, DEWATERING, AND ANY OTHER OPERATION THAT INCREASES THE EROSION POTENTIAL ON THE PROJECT.

THE OPERATOR WILL PERFORM A PRECONSTRUCTION SITE VISIT TO ADDRESS ANY AREAS OF CONCERN PERTAINING TO ENVIRONMENTAL COMPLIANCE. THE OPERATOR WILL IMPLEMENT AND MAINTAIN BMPs FOR THE DURATION OF CONSTRUCTION PROJECT. THE OPERATOR WILL COMPLETE THE REQUIRED SITE INSPECTIONS.

ISG INC. HAS BEEN CONTRACTED BY THE OWNER TO DEVELOP THE EROSION CONTROL PLAN FOR THIS PROJECT. ISG INC. WILL OFFER GUIDANCE FOR COMPLIANCE WITH THE WPDES PERMIT BEFORE, DURING, AND AFTER CONSTRUCTION OF THE PROJECT.

DESIGNER:
ISG INC. (XXXXXXXX)
201 MAIN ST., SUITE 1020
LA CROSSE, WI 54601
XXX-XXX-XXXXXXX@ISGINC.COM

PERMANENT STORMWATER MANAGEMENT DESIGNER:
ISG INC. (XXXXXXXXXXXX)
201 MAIN ST., SUITE 1020
LA CROSSE, WI 54601
XXX-XXX-XXXXXXX@ISGINC.COM

EXISTING SITE CONDITIONS, SOILS, & WATER RESOURCES

SOILS AND NATIVE TOPSOIL: NATIVE TOPSOIL WILL BE STRIPPED AND STOCKPILED FOR FINAL GRADING OPERATIONS, WHERE INDICATED IN THE CONSTRUCTION PLANS AND SPECIFICATIONS. METHODS AND EQUIPMENT TO MINIMIZE SOIL COMPACTION (IN PROPOSED INFILTRATION AREAS, DRIP LINE OF TREES TO BE PRESERVED, ETC.) SHALL BE DETERMINED BY THE OPERATOR'S EROSION CONTROL PLAN AMENDMENT. TRACKED VEHICLES ARE PREFERRED AND WHEELED VEHICLES ARE DISCOURAGED IN THESE AREAS. THE ON-SITE SOILS INCLUDE TOPSOIL, SAND AND LEAN CLAY AT X% TO X% SLOPES. REFER TO THE GEOTECHNICAL REPORT INCLUDED WITHIN THE PROJECT SPECIFICATIONS FOR MORE DETAILED SOIL INFORMATION. THE EXISTING SITE INCLUDES PAVED AND GRAVEL SURFACING. VEGETATED AREAS ARE GRASS IN FAIR CONDITION AND A PORTION OF THE SITE IS FARMED. NO HISTORIC SITE CONTAMINATION IS KNOWN.

IMMEDIATE RECEIVING WATERS: STORMWATER FROM THIS PROJECT WILL BE CONVEYED INTO SEVERAL CONSTRUCTED DITCHES AND STORMWATER PONDS. PROJECT DISCHARGE POINTS DISCHARGE TO DES PLAINES RIVER (WBC 734000). A RECEIVING WATERS REVIEW WAS COMPLETED ON X/XX/2018. BASED ON THIS REVIEW THE RECEIVING WATER DES PLAINES RIVER IS AN OUTSTANDING RESOURCE WATER (ORW), EXCEPTIONAL RESOURCE WATER (ERW), FISH AND AQUATIC LIFE WATER AND/OR AN IMPAIRED WATER, THEREFORE SECTION 4.4 REQUIREMENTS APPLY TO THIS PROJECT.

THE RECEIVING WATER DES PLAINES RIVER IS NOT AN OUTSTANDING RESOURCE WATER (ORW), EXCEPTIONAL RESOURCE WATER (ERW), FISH AND AQUATIC LIFE WATER AND/OR AN IMPAIRED WATER

ORW, ERW AND IMPAIRED WATER STORMWATER DISCHARGE: STORMWATER DISCHARGE THAT WOULD FIRST OCCUR AFTER THE PERMITTEE'S START DATE OF COVERAGE TO A SURFACE WATER TO WHICH THE SITE DID NOT PREVIOUSLY DISCHARGE STORM WATER SHALL NOT BE ESTABLISHED DIRECTLY TO AN ORW, ERW, FISH AND AQUATIC LIFE WATER OR IMPAIRED WATER UNLESS THE DISCHARGE OF POLLUTANTS IS LESS THAN OR EQUAL TO THE EXISTING LEVELS OF POLLUTANTS IMMEDIATELY UPSTREAM OF THE DISCHARGE SITE.

PROTECTIVE AREA OF NO LESS THAN 75 FEET SHALL BE MAINTAINED TO ANY ORW AND ERW.

DISCHARGE OF POLLUTANT(S) OF CONCERN VIA STORMWATER TO AN IMPAIRED WATER OR APPROVED TMDL SHALL BE MANAGED BY XXXX CONTROL MEASURES AND MANAGEMENT PRACTICES THAT WILL COLLECTIVELY BE USED TO REDUCE OR ELIMINATE THE STORMWATER DISCHARGE OF POLLUTANT(S) OF CONCERN THAT CONTRIBUTE TO THE IMPAIRMENT OF THE WATER BODY. THESE CONTROL MEASURES AND MANAGEMENT PRACTICES WERE CHOSEN OPPOSED TO OTHER ALTERNATIVES BECAUSE XXX.

PERMANENT STORMWATER TREATMENT SYSTEMS

THIS SITE IS A NEW DEVELOPMENT / REDEVELOPMENT AND IS REQUIRED TO MEET XX% TSS REMOVAL FROM THE POST-CONSTRUCTION SITE. POST-DEVELOPMENT PEAK RUNOFF DISCHARGE RATES SHALL BE EQUAL TO OR LESS THAN PRE-DEVELOPMENT CONDITIONS FOR THE 1-YEAR, 24-HOUR AND THE 2-YEAR, 24-HOUR DESIGN STORMS. THE POST-DEVELOPMENT SITE HAS LOW / MODERATE / HIGH IMPERVIOUSNESS AND SHALL INFILTRATE AT LEAST XX% OF THE PRE-DEVELOPMENT INFILTRATION VOLUME. HYDROLOGIC AND WATER QUALITY MODELING DATA AND THE CONTAMINATION CHECKLIST IS AVAILABLE UPON REQUEST.

POTENTIAL FOR SEDIMENT AND/OR OTHER POLLUTANT(S) DISCHARGING FROM THE PROJECT SITE

THE TEMPORARY EROSION AND SEDIMENT CONTROL BMPs IN THIS EROSION CONTROL PLAN HAVE BEEN DESIGNED TO MINIMIZE THE POTENTIAL OF SEDIMENTS DISCHARGING OFF-SITE FROM A 0.5 INCH RAINFALL WITHIN A 24 HOUR PERIOD. THE NOAA ATLAS 14 POINT PRECIPITATION FREQUENCY ESTIMATE FOR THE PROJECT LOCATION WAS REVIEWED AND USED FOR ANTICIPATED INSPECTION FREQUENCY, BMP DESIGN, AND ESTIMATING CONSTRUCTION ACTIVITIES IN THIS EROSION CONTROL PLAN. ATLAS 14 RESULTS DO NOT NECESSARILY REFLECT ANY DESIGN CRITERIA IN THE PERMANENT STORMWATER MANAGEMENT SYSTEM.

ROUTINE INSPECTION AND BMP MAINTENANCE BY THE OPERATOR IS CRUCIAL IN ENSURING THE FUNCTIONALITY OF EACH BMP. STEEP SLOPES AND OTHER ENVIRONMENTALLY SENSITIVE AREAS THAT ARE AT A HIGHER RISK OF SEDIMENTATION ARE DEFINED IN THIS SWPPP (IF APPLICABLE).

CONSTRUCTION PHASING/STAGING, BUFFERS, & AREAS NOT TO BE DISTURBED

AREAS NOT TO BE DISTURBED ARE TO BE DELINEATED BEFORE WORK BEGINS. PERMITTEES ARE RESPONSIBLE FOR PRESERVING A 75 FOOT NATURAL BUFFER OR (IF INFEASIBLE AND DOCUMENTED) PROVIDE REDUNDANT SEDIMENT CONTROL BMPs, WHEN A SURFACE WATER IS LOCATED WITHIN 50 FEET AND RECEIVES DRAINAGE FROM THE PROJECT'S GRADING LIMITS. THIS REQUIREMENT DOES NOT APPLY TO ADJACENT ROADSIDE DITCHES, JUDICIAL/COUNTY DITCHES, STORMWATER CONVEYANCES, STORM DRAIN INLETS, AND SEDIMENT BASINS.

EXISTING VEGETATION SHALL BE PRESERVED WHERE FEASIBLE AND LAND DISTURBING CONSTRUCTION ACTIVITIES SHALL BE STAGED TO LIMIT EXPOSED SOIL AREAS SUBJECT TO EROSION. DISTURBED PORTIONS OF THE CONSTRUCTION SITE ARE TO BE TEMPORARILY OR PERMANENTLY STABILIZED AS SOON AS PRACTICABLE AND SHALL BE INITIATED NO LATER THAN THE END OF THE NEXT WORKDAY FOLLOWING THE DAY EARTH-DISTURBING ACTIVITIES IN THAT PORTION OF THE SITE HAS TEMPORARILY OR PERMANENTLY CEASED. INITIATED STABILIZATION IS DEFINED AS COMPLETING ONE (OR MORE) OF THE FOLLOWING: SOIL PREPARATION FOR VEGETATION, MULCHING (OR OTHER TEMPORARY NON-VEGETATIVE BMP), SEEDING/PLANTING, OR SCHEDULING STABILIZATION MEASURES TO BE FULLY INSTALLED AND COMPLETED AS SOON AS PRACTICABLE.

EROSION AND SEDIMENT CONTROL BMPs

EROSION AND SEDIMENT CONTROL PRACTICES SHALL BE USED TO PREVENT OR REDUCE THE FOLLOWING IN ORDER TO DISCHARGE NO MORE THAN 5 TONS PER ACRE PER YEAR OF SEDIMENT FROM THE DISTURBED AREA.

THE OPERATOR SHALL CLEARLY IDENTIFY THE CONTRACTOR(S) AND SUBCONTRACTOR(S) THAT ARE RESPONSIBLE FOR THE INSTALLATION, OPERATION, AND CONTINUED MAINTENANCE OF ALL TEMPORARY AND PERMANENT WATER QUALITY MANAGEMENT BMPs, AS WELL AS ALL EROSION PREVENTION AND SEDIMENT CONTROL BMPs, FOR THE DURATION OF THE CONSTRUCTION WORK AT THE SITE, UNTIL FINAL STABILIZATION IS ACHIEVED. ALL BMPs MUST BE ADEQUATELY LOCATED, DESIGNED, INSTALLED, AND MAINTAINED TO PREVENT EROSION FROM A MINIMUM 0.5 INCH TOTAL RAINFALL EVENT WITHIN 24 HOURS.

ALL NONFUNCTIONAL BMPs MUST BE REPAIRED, REPLACED, OR SUPPLEMENTED WITH FUNCTIONAL BMPs BY THE END OF THE NEXT BUSINESS DAY AFTER DISCOVERY, OR AS SOON AS FIELD CONDITIONS ALLOW ACCESS UNLESS ANOTHER TIME FRAME IS SPECIFIED IN THE EROSION CONTROL PLAN. ALL ERODED MATERIAL THAT LEAVES THE SITE SHALL BE COLLECTED BY THE OPERATOR AND RETURNED TO THE SITE AT THE OPERATOR'S EXPENSE AND INCIDENTAL TO THE PROJECT COST.

TEMPORARY STABILIZATION BMPs SHALL ONLY BE IMPLEMENTED WHEN PERMANENT STABILIZATION BMPs CANNOT BE IMPLEMENTED WITHIN A REASONABLE TIMEFRAME FOR EXPOSED SOILS.

DEWATERING

DEWATERING, STREAM DIVERSION, OR BASIN DRAINING MAY BE REQUIRED DURING CONSTRUCTION OF THIS PROJECT. WHEN DEWATERING IS REQUIRED, THE CONTRACTOR SHALL SUBMIT A DEWATERING PLAN AND NARRATIVE TO THE PROJECT ENGINEER FOR APPROVAL PRIOR TO UNDERTAKING THESE ACTIVITIES. DEWATERING PLAN MUST BE DESIGNED IN ACCORDANCE WITH WI DNR TECHNICAL STANDARD 1081 INCLUDE BMPs TO PREVENT SEDIMENT TRANSPORT, EROSION, AND ADVERSE IMPACTS TO DOWNSTREAM RECEIVING WATERS. THE DEWATERING PLAN MUST ALSO INCLUDE ANY SPECIFIC CHEMICAL TREATMENTS (FLOC, POLYMERS, ETC.) THAT WILL BE USED. THE DEWATERING PLAN AND DNR APPROPRIATIONS PERMIT WILL BECOME PART OF THE EROSION CONTROL PLAN. WATER THAT IS TURBID OR HAS SEDIMENT MUST BE DISCHARGED TO A TEMPORARY OR PERMANENT SEDIMENTATION BASIN (AND/OR OTHER APPROPRIATE BMPs) ON THE PROJECT SITE WHENEVER POSSIBLE. DISCHARGE FROM THE TEMPORARY OR PERMANENT SEDIMENTATION BASIN MUST BE VISUALLY CHECKED TO ENSURE ADEQUATE TREATMENT IS OBTAINED IN THE BASIN AND THAT NUISANCE CONDITIONS, IMPACTS TO WETLANDS, AND EROSION IN RECEIVING CHANNELS OR ON DOWNSLOPE PROPERTIES WILL NOT RESULT FROM THE DISCHARGE. THE DISCHARGE MUST BE DISPERSED OVER NATURAL ROCK RIPRAP, SANDBAGS, PLASTIC SHEETING, OR OTHER ACCEPTED ENERGY DISSIPATION MEASURES. ADEQUATE SEDIMENTATION CONTROL MEASURES AND ADDITIONAL FILTRATION BMPs ARE REQUIRED FOR DISCHARGE WATER THAT CONTAINS SUSPENDED SOLIDS, OIL, OR GREASE.

SEQUENCE OF CONSTRUCTION/TIMING OF BMP INSTALLATION

NO CONSTRUCTION OPERATIONS, INCLUDING REMOVALS, THAT REQUIRE EROSION & SEDIMENT CONTROL PER THE EROSION CONTROL PLAN CAN COMMENCE UNTIL THE OPERATOR'S EROSION CONTROL SUPERVISOR CERTIFIES THE PROPER INSTALLATION OF BMPs AND A CHAIN OF RESPONSIBILITY FOR EROSION CONTROL PLAN IMPLEMENTATION IS CREATED FOR ALL OPERATORS ON THE SITE. PERIMETER SEDIMENT CONTROLS (SILT FENCE, INLET PROTECTION, CONSTRUCTION ENTRANCES, ETC.) SHALL BE INSTALLED PRIOR TO THE START OF CONSTRUCTION. THESE PRACTICES SHALL REMAIN IN PLACE UNTIL FINAL STABILIZATION IS ACHIEVED. OPERATOR SHALL IMPLEMENT THE NECESSARY ON-SITE BMPs IN ACCORDANCE WITH THE WPDES PERMIT REQUIREMENTS TO PREVENT NUISANCE CONDITIONS FROM ANY DISCHARGES UNDER COVERAGE OF THE WPDES PERMIT. IN SOME CASES, MULTIPLE OR REDUNDANT APPLICATIONS OF SOME BMPs MAY BE NEEDED TO MEET THESE REQUIREMENTS.

TEMPORARY & PERMANENT EROSION PREVENTION BMPs

TEMPORARY/PERMANENT DRAINAGE DITCHES & SWALES: THE NORMAL WETTED PERIMETER (2-YEAR, 24-HOUR PRECIPITATION EVENT) OF ANY TEMPORARY OR PERMANENT DRAINAGE DITCH, CHANNEL, OR SWALE THAT DRAINS WATER FROM ANY PORTION OF THE CONSTRUCTION SITE, OR DIVERTS WATER AROUND THE SITE, MUST BE STABILIZED WITHIN THE LAST 200 LINEAL FEET FROM THE PROPERTY EDGE, OR FROM THE POINT OF DISCHARGE INTO ANY SURFACE WATER WITHIN 24 HOURS OF CONNECTION. STABILIZATION REMAINING OF THE REMAINING PORTIONS OF THE CHANNEL MUST BE STABILIZED WITHIN 14 DAYS. ALL STORMWATER CONVEYANCE CHANNELS MUST USE EROSION CONTROL AND VELOCITY DISSIPATION DEVICES WITHIN AND ALONG THE LENGTH OF THE CHANNEL AND AT ANY OUTLETS. TEMPORARY OR PERMANENT DITCHES OR SWALES THAT ARE BEING USED AS A TEMPORARY SEDIMENT CONTAINMENT SYSTEM (WITH PROPERLY DESIGNED ROCK DITCH CHECKS, BIO ROLLS, SILT DIKES ETC.) DO NOT NEED TO BE STABILIZED. THESE AREAS HOWEVER MUST BE STABILIZED WITHIN 24 HOURS AFTER NO LONGER BEING USED AS A SEDIMENT CONTAINMENT SYSTEM. MULCH, HYDROMULCH, TACKIFIER, OR POLYACRYLAMIDE BELOW THE WETTED PERIMETER OF A DITCH, SWALE, OR OTHER SURFACE WATER CONVEYANCE IS NOT ACCEPTABLE STABILIZATION.

EROSION CONTROL BLANKETS/MATS: OPERATOR SHALL VERIFY DURING REGULAR INSPECTIONS THAT NO GULLIES, RILLS, OR SCOUR HOLES HAVE FORMED UNDER EROSION CONTROL BLANKETS AND MATS. ALL REPAIRS MUST BE COMPLETED WITHIN 24 HOURS OF DISCOVERY, OR AS SOON AS FIELD CONDITIONS ALLOW ACCESS. USE THE REQUIRED CLASS AND TYPE OF EROSION MAT THE PLANS SHOW OR IS SPECIFIED.

MULCH: OPERATOR MUST APPLY MULCH IN A UNIFORM PATTERN OVER THE DISTURBED SOILS, TO ACHIEVE A MINIMUM OF 90% GROUND COVER.
METHOD A, NETTING: SECURELY ANCHOR MULCHING MATERIAL BY APPROVED NETTING AND PEGS OR STAPLES
METHOD B, TACKIFIER: UTILIZE A TACKIFIER TO TREAT OR APPLY TO THE MULCHING MATERIAL

DUST CONTROL: DUST FROM THE SITE WILL BE CONTROLLED BY INCREASED STREET SWEEPING AND/OR USING A MOBILE PRESSURE-TYPE DISTRIBUTOR TRUCK TO APPLY POTABLE WATER TO DISTURBED AREAS. THE MOBILE UNIT WILL APPLY WATER AT A RATE NECESSARY TO PREVENT RUNOFF AND PONDING.

STORM SEWER OUTLETS: PIPE OUTLETS MUST HAVE TEMPORARY OR PERMANENT ENERGY DISSIPATION WITHIN 24 HOURS AFTER HYDRAULIC CONNECTION TO A RECEIVING SURFACE WATER.

TEMPORARY WINTER COVER: AREAS OF EXPOSED SOILS THAT ARE NOT COMPLETED BEFORE THE WINTER SHALL BE STABILIZED BEFORE CONSTRUCTION IS COMPLETED FOR THE SEASON.

TEMPORARY & PERMANENT SEDIMENT CONTROL BMPs

DOWNGRADIENT SYSTEMS: IF THE DOWNGRADIENT TREATMENT SYSTEM IS OVERLOADED, ADDITIONAL UP GRADIENT SEDIMENT CONTROL PRACTICES OR REDUNDANT BMPs MUST BE INSTALLED TO ELIMINATE THE OVERLOADING, AND THE EROSION CONTROL PLAN MUST BE AMENDED TO IDENTIFY THESE ADDITIONAL PRACTICES.

PERIMETER CONTROL BMPs (SILT FENCES, CHIP/SLASH MULCH SACKS, BIOROLLS, FLOATING SILT CURTAIN, ETC.): PERIMETER CONTROL BMPs SHALL BE INSTALLED ON ALL DOWNGRADIENT PERIMETERS AND UPGRADED IF ANY BUFFER AREAS, PRIOR TO INITIATING UPGRADED LAND DISTURBANCE ACTIVITIES. UPLAND PERIMETER CONTROLS BMPs SHALL BE PLACED AS CLOSE AS POSSIBLE TO FOLLOW A SINGLE CONTOUR ELEVATION. ALL PERIMETER CONTROL DEVICES MUST BE REPAIRED, REPLACED, OR MAINTAINED WHEN THEY BECOME NONFUNCTIONAL OR THE SEDIMENT REACHES 1/2 OF THE HEIGHT OF THE DEVICE. FLOATING SILT CURTAIN SHALL BE INSTALLED AS CLOSE TO THE SHORELINE AS POSSIBLE FOR SHORELAND-IN-WATER SHORT-TERM CONSTRUCTION ACTIVITIES. IMMEDIATELY AFTER THE SHORT-TERM ACTIVITY IN THAT AREA IS COMPLETE, AN UPLAND PERIMETER CONTROL MUST BE INSTALLED IF EXPOSED SOILS CONTINUE TO DRAIN TO THE SURFACE WATER.

TEMPORARY SEDIMENTATION BASINS AND TRAPS: THE BASIN INTAKE MUST BE DESIGNED IN ACCORDANCE WITH WI DNR TECHNICAL STANDARD 1083. THE BASIN SHALL WITHDRAW WATER FROM THE SURFACE, PREVENT SHORT CIRCUITING AND THE DISCHARGE OF FLOATING DEBRIS. INCLUDE AN EMERGENCY OVERFLOW ABOVE THE LIVE STORAGE ELEVATION, AND PROVIDE ENERGY DISSIPATION AT THE BASIN OUTLET. BASINS MUST BE DRAINED AND SEDIMENT REMOVED WHEN THE DEPTH OF COLLECTED SEDIMENT IN THE BASIN REACHES 1/2 THE LIVE STORAGE VOLUME.

TEMPORARY STOCKPILES: ALL STOCKPILES MUST HAVE SILT FENCE OR EQUIVALENT PERIMETER SEDIMENT CONTROLS IMPLEMENTED AND MAINTAINED AT ALL TIMES. PILES CANNOT BE PLACED IN BUFFER AREAS OR SURFACE WATERS, INCLUDING STORMWATER CONVEYANCES SUCH AS CURB AND GUTTER SYSTEMS, OR CONDUITS AND DITCHES UNLESS THERE IS A BYPASS IN PLACE TO PREVENT STORMWATER RUN-ON INTO THE STOCKPILE. STABILIZATION ON TEMPORARY STOCKPILES WITHOUT SIGNIFICANT SILT, CLAY OR ORGANIC COMPONENTS IS NOT REQUIRED.

CONSTRUCTION SITE ENTRANCE/VEHICLE TRACKING: OPERATOR MUST MINIMIZE SEDIMENT FROM LEAVING THE CONSTRUCTION SITE (OR ONTO STREETS WITHIN THE SITE) BY IMPLEMENTING BMPs SUCH AS ROCK PADS, SLASH MULCH, CONCRETE OR STEEL WASH RACKS, OR EQUIVALENT SYSTEMS. STREET SWEEPING MUST BE USED DAILY DURING CONSTRUCTION OPERATIONS IF SUCH BMPs ARE NOT ADEQUATE TO PREVENT SEDIMENT FROM BEING TRACKED ONTO THE STREET. TRACKED SEDIMENT MUST BE REMOVED FROM ALL PAVED SURFACES (ON AND OFF-SITE) WITHIN 24 HOURS OF DISCOVERY, OR SOONER AS DIRECTED BY THE PROJECT OWNER. MULTIPLE STREET SWEEPINGS AT THE OPERATOR'S EXPENSE MAY BE REQUIRED ON ALL ENTRY/EXIT POINTS TO THE SITE AT THE DISCRETION OF THE PROJECT OWNER.

SURFACE WATERS: INCLUDING OFF-SITE AND DOWNSTREAM DRAINAGE DITCHES, CATCH BASINS, AND CONVEYANCE SYSTEMS, MUST BE INSPECTED FOR EVIDENCE OF EROSION AND SEDIMENT DEPOSITION. THE REMOVAL AND STABILIZATION OF EXPOSED SOILS MUST TAKE PLACE WITHIN SEVEN (7) DAYS OF DISCOVERY UNLESS PRECLUDED BY LEGAL, REGULATORY, OR PHYSICAL ACCESS CONSTRAINTS. IF PRECLUDED, REMOVAL AND STABILIZATION MUST TAKE PLACE WITHIN SEVEN (7) CALENDAR DAYS OF OBTAINING ACCESS. THE PERMITTEES ARE RESPONSIBLE FOR CONTACTING ALL LOCAL, REGIONAL, STATE AND FEDERAL AGENCIES AND RECEIVING ANY APPLICABLE PERMITS, PRIOR TO CONDUCTING ANY WORK.

INLET PROTECTION: ALL STORM DRAIN INLETS (INCLUDING DOWNGRADIENT, OFF-SITE) MUST BE PROTECTED BY APPROPRIATE BMPs DURING CONSTRUCTION UNTIL ALL SOURCES WITH POTENTIAL FOR DISCHARGING TO THE INLET HAVE BEEN STABILIZED. SILT FENCE IS NOT AN ACCEPTABLE CATCH BASIN INLET PROTECTION BMP. CONTACTOR SHALL CLEAN, REMOVE AND DISPOSE OF SEDIMENT, AND/OR REPLACE STORM DRAIN INLET PROTECTION ON A ROUTINE BASIS TO ENSURE THE DEVICE IS FULLY FUNCTIONAL PRIOR TO THE NEXT FORECASTED PRECIPITATION EVENT (90% OR GREATER). INLET PROTECTION MAY BE REMOVED FOR A PARTICULAR INLET IF A SPECIFIC SAFETY CONCERN (STREET FLOODING/FREEZING) HAS BEEN IDENTIFIED BY THE PERMITTEE(S) OR THE JURISDICTIONAL AUTHORITY (E.G. CITY/COUNTY/TOWNSHIP/DOT ENGINEER). WRITTEN CORRESPONDENCE REGARDING THE NEED FOR REMOVAL MUST BE DOCUMENTED IN THE EROSION CONTROL PLAN.

CHEMICAL TREATMENTS: OPERATOR MUST AMEND THE SWPEROSION CONTROL PLAN TO INCLUDE THE INTENDED USES AND LOCATIONS OF FLOCCULANTS, POLYMERS, AND OTHER SEDIMENTATION TREATMENT CHEMICALS. CHEMICAL TREATMENTS MAY ONLY BE APPLIED IN AREAS WHERE TREATED STORMWATER IS DIRECTED TO A RECEIVING SEDIMENT CONTROL SYSTEM (NOT DIRECTLY DISCHARGED TO NATURAL WATER BODIES). THIS INCLUDES DOCUMENTING THE EXPECTED SOIL TYPES, MANUFACTURER'S RECOMMENDED DOSING, APPLICATION RATES/QUANTITIES, AND MONITORING RESULTS (TURBIDITY, PH).

POLLUTION PREVENTION MANAGEMENT MEASURES

THE FOLLOWING PREVENTATIVE MEASURES SHALL BE INCORPORATED:

1. MAINTENANCE OF EXISTING VEGETATION, ESPECIALLY ADJACENT TO SURFACE WATERS WHENEVER POSSIBLE;
2. MINIMIZATION OF SOIL COMPACTION AND PRESERVATION OF TOP SOIL;



SHEET NOT VALID UNLESS THIS TEXT IS COLOR.

THIS DOCUMENT IS THE PROPERTY OF I & S GROUP, INC. AND MAY NOT BE USED, COPIED OR DUPLICATED WITHOUT PRIOR WRITTEN CONSENT.
©2024 I & S GROUP, INC.

PROJECT

**BORTON
CONSTRUCTION
NEW OFFICE**

LA CROSSE

WISCONSIN

REVISION SCHEDULE

DATE	DESCRIPTION	BY

PROJECT NO. 26-34320

FILE NAME 34320 C1-SWPPP

DRAWN BY AAE

DESIGNED BY AAE

REVIEWED BY KBR

ORIGINAL ISSUE DATE 06/05/2026

CLIENT PROJECT NO. -

TITLE

SWPPP NARITIVE

SHEET

C1-10

3. MINIMIZATION OF LAND DISTURBING CONSTRUCTION ACTIVITY ON SLOPES OF 20% OR MORE;
4. DEVELOPMENT OF SPILL PREVENTION AND RESPONSE PROCEDURES.

POTENTIAL SOURCES OF UNAUTHORIZED DISCHARGES CONSTRUCTION ACTIVITIES INCLUDE WASTEWATER DISCHARGES FROM WASHOUT AND CLEANOUT OF STUCCO, PAINT, FORM RELEASE OILS, CURING COMPOUNDS AND OTHER CONSTRUCTION MATERIALS; FUELS, OILS AND OTHER POLLUTANTS USED IN VEHICLE OPERATION AND MAINTENANCE; AND SOAPS OR SOLVENTS USED IN VEHICLE AND/OR EQUIPMENT WASHING.

THE PERMITTEE SHALL NOTIFY THE DEPARTMENT OF ANY RELEASE OR SPILL OF A HAZARDOUS SUBSTANCE TO THE ENVIRONMENT IN ACCORDANCE WITH S. 292.11, WIS. STATS., AND CH. CR 706 WIS. ADM. CODE AT (800) 943-0003.

INSPECTIONS & MAINTENANCE

THE OPERATOR MUST INSPECT THE ENTIRE CONSTRUCTION SITE AT LEAST ONCE EVERY SEVEN (7) DAYS DURING ACTIVE CONSTRUCTION AND WITHIN 24 HOURS AFTER A RAINFALL EVENT GREATER THAN 0.5 INCHES IN 24 HOURS. THE OPERATOR SHALL PROVIDE A RAINFALL GAUGE ON-SITE, WITHIN ONE MILE OF THE SITE, OR SOURCE OF THE WEATHER REPORTING SYSTEM THAT USES SITE SPECIFIC RAINFALL DATA FROM RADAR SUMMARIES. THE LOCATION AND SOURCE OF THE RAINFALL GAUGE OR REPORTING SYSTEM MUST BE DOCUMENTED IN THE FIRST EROSION CONTROL INSPECTION REPORT. ALL MAINTENANCE SHALL BE DONE IN ACCORDANCE WITH TECHNICAL STANDARDS DEVELOPED PURSUANT TO SUBCH. V OF CH. NR 151, WIS. ADM. CODE. ALL INSPECTIONS AND MAINTENANCE CONDUCTED MUST BE RECORDED IN WRITING BY THE OPERATOR AND RETAINED WITH THE EROSION CONTROL PLAN. THE DEPARTMENT HAS DEVELOPED A MODEL INSPECTION REPORT AVAILABLE AT [HTTP://DNR.WI.GOV/TOPI/STORMWATER/CONSTRUCTION/FORMS.HTML](http://dnr.wi.gov/topic/stormwater/construction/forms.html) OR AVAILABLE UPON REQUEST FOR THE PROJECT OWNER. RECORDS OF EACH INSPECTION AND MAINTENANCE ACTIVITY SHALL INCLUDE:

- A. DATE, TIME AND EXACT LOCATION OF THE INSPECTION;
- B. NAME OF PERSON(S) CONDUCTING INSPECTIONS;
- C. AN ASSESSMENT OF THE CONDITION OF EROSION AND SEDIMENT CONTROLS;
- D. A DESCRIPTION OF ANY EROSION AND SEDIMENT CONTROL INSTALLATION OR MAINTENANCE PERFORMED IN RESPONSE TO THE INSPECTION;
- E. DESCRIPTION OF THE PRESENT PHASE OF CONSTRUCTION AT THE SITE AND ANY SCHEDULE MODIFICATIONS THAT MAY INCREASE SEDIMENT DISCHARGE.

THE OWNER SHALL BE IN CHARGE OF THE LONG-TERM MAINTENANCE OF PERMANENT BMPS.

EROSION CONTROL PLAN AMENDMENTS & RECORD KEEPING

EROSION CONTROL PLAN AMENDMENTS AND SITE PLANS WILL BE PREPARED BY THE OPERATOR AND SUBMITTED TO THE OWNER FOR REVIEW AND WRITTEN APPROVAL BY THE PROJECT OWNER (OR DESIGNATED REPRESENTATIVE). ALL OWNER ACCEPTED AND DENIED EROSION CONTROL PLAN AMENDMENTS AND SITE PLANS MUST BE RECORDED IN WRITING AND RETAINED WITH THE EROSION CONTROL PLAN.

THE EROSION CONTROL PLAN SHALL BE AMENDED IF:

1. THERE IS A CHANGE IN DESIGN, CONSTRUCTION, OPERATION OR MAINTENANCE AT THE CONSTRUCTION SITE, WHICH HAS THE REASONABLE POTENTIAL FOR THE DISCHARGE OF POLLUTANTS AND WHICH HAS NOT OTHERWISE BEEN ADDRESSED IN THE EROSION CONTROL AND STORM WATER MANAGEMENT PLANS;
2. THERE IS A CHANGE IN THE SEQUENCE, SCHEDULE, OR PHASING OF CONSTRUCTION AT THE CONSTRUCTION SITE WHICH HAS A REASONABLE POTENTIAL TO CAUSE AN EXCEEDANCE OF THE 5 TONS PER ACRE PER YEAR SEDIMENT PERFORMANCE STANDARD;
3. THE ACTIONS REQUIRED BY THE EROSION CONTROL AND STORM WATER MANAGEMENT PLANS FAIL TO REDUCE THE IMPACTS OF POLLUTANTS CARRIED BY CONSTRUCTION SITE STORM WATER RUNOFF.

FOR CONSTRUCTION SITES FOR WHICH THERE HAS BEEN EARLIER DEPARTMENT REVIEW OF THE EROSION CONTROL AND STORM WATER MANAGEMENT PLANS, IF THE PERMITTEE IDENTIFIES CHANGES NEEDED IN EITHER PLAN, THE PERMITTEE SHALL NOTIFY THE DEPARTMENT AT LEAST 5 WORKING DAYS PRIOR TO MAKING THE CHANGES IN THE PLAN.

THE EROSION CONTROL PLAN (ORIGINAL OR COPIES), ALL CHANGES TO THE EROSION CONTROL PLAN, PROJECT MANUAL, AND INSPECTIONS/MAINTENANCE RECORDS MUST BE KEPT AT THE SITE DURING CONSTRUCTION BY THE OPERATOR WHO HAS OPERATIONAL CONTROL OF THAT PORTION OF THE SITE. THE EROSION CONTROL PLAN CAN BE KEPT IN THE FIELD OFFICE OR ON SITE VEHICLE DURING NORMAL WORKING HOURS. THE PERMITTEES MUST KEEP AND MAKE AVAILABLE TO FEDERAL, STATE, AND LOCAL OFFICIALS WITHIN FIVE DAYS THE EROSION CONTROL PLAN, OTHER STORMWATER RELATED PERMITS, RECORDS OF ALL INSPECTION/MAINTENANCE, ALL PERMANENT OPERATIONS AND MAINTENANCE AGREEMENTS, ALL REQUIRED CALCULATIONS FOR DESIGN OF THE TEMPORARY AND PERMANENT STORMWATER MANAGEMENT SYSTEMS AND OTHER INFORMATION REQUIRED BY THE GENERAL PERMIT FOR THREE YEARS FOLLOWING THE NOTICE OF TERMINATION.

NOTICE OF TERMINATION

THE PERMITTEE SHALL SIGN AND SUBMIT A NOTICE OF TERMINATION (NOT) (AVAILABLE THROUGH THE DEPARTMENT AT [HTTP://DNR.WI.GOV/TOPI/STORMWATER/CONSTRUCTION/FORMS.HTML](http://dnr.wi.gov/topic/stormwater/construction/forms.html)) TO THE DEPARTMENT WITHIN 45 DAYS AFTER FINAL STABILIZATION, REMOVAL OF TEMPORARY EROSION CONTROL BMPS AND ALL LAND DISTURBING CONSTRUCTION ACTIVITY UNDER THIS PERMIT HAVE CEASED.

FINAL STABILIZATION MEANS THAT ALL LAND DISTURBING CONSTRUCTION ACTIVITIES AT THE CONSTRUCTION SITE HAVE BEEN COMPLETED AND THAT A UNIFORM PERENNIAL VEGETATIVE COVER HAS BEEN ESTABLISHED WITH A DENSITY OF AT LEAST 70% OF THE COVER FOR THE UNPAVED AREAS AND AREAS NOT COVERED BY PERMANENT STRUCTURES OR THAT EMPLOY EQUIVALENT PERMANENT STABILIZATION MEASURES.

TERMINATION OF COVERAGE UNDER THIS PERMIT SHALL BE EFFECTIVE UPON THE DEPARTMENT'S WRITTEN CONFIRMATION OF PERMIT TERMINATION TO THE PERMITTEE.

EROSION CONTROL NOTES:

1. POST WDNR CERTIFICATE OF PERMIT COVERAGE ON SITE AND MAINTAIN UNTIL CONSTRUCTION ACTIVITIES HAVE CEASED, THE SITE IS STABILIZED, AND A NOTICE OF TERMINATION IS FILED WITH WDNR.
2. KEEP A COPY OF THE CURRENT EROSION CONTROL PLAN ON SITE THROUGHOUT THE DURATION OF THE PROJECT.
3. SUBMIT PLAN REVISIONS OR AMENDMENTS TO THE WDNR AT LEAST 5 DAYS PRIOR TO FIELD IMPLEMENTATION.
4. THE CONTRACTOR IS RESPONSIBLE FOR ROUTINE SITE INSPECTIONS AT LEAST ONCE EVERY 7 DAYS AND WITHIN 24 HOURS AFTER A RAINFALL EVENT OF 0.5 INCHES OR GREATER. KEEP INSPECTION REPORTS ON-SITE AND MAKE THEM AVAILABLE UPON REQUEST.
5. INSPECT AND MAINTAIN ALL INSTALLED EROSION CONTROL PRACTICES UNTIL THE CONTRIBUTING DRAINAGE AREA HAS BEEN STABILIZED.
6. WHEN POSSIBLE: PRESERVE EXISTING VEGETATION (ESPECIALLY ADJACENT TO SURFACE WATERS), MINIMIZE LAND-DISTURBING CONSTRUCTION ACTIVITY ON SLOPES OF 20% OR MORE, MINIMIZE SOIL COMPACTION, AND PRESERVE TOPSOIL.
7. REFER TO THE WDNR STORMWATER CONSTRUCTION TECHNICAL STANDARDS AT [HTTP://DNR.WI.GOV/TOPI/STORMWATER/STANDARDS/CONST_STANDARDS.HTML](http://dnr.wi.gov/topic/stormwater/standards/const_standards.html)
8. INSTALL PERIMETER EROSION CONTROLS AND ROCK TRACKING PAD CONSTRUCTION ENTRANCE(S) PRIOR TO ANY LAND-DISTURBING ACTIVITIES, INCLUDING CLEARING AND GRUBBING. USE WDNR TECHNICAL STANDARD STONE TRACKING PAD AND TIRE WASHING #1057 FOR ROCK CONSTRUCTION ENTRANCE(S).
9. INSTALL INLET PROTECTION PRIOR TO LAND-DISTURBING ACTIVITIES IN THE CONTRIBUTING DRAINAGE AREA AND/OR IMMEDIATELY UPON INLET INSTALLATION. COMPLY WITH WDNR TECHNICAL STANDARD STORM DRAIN INLET PROTECTION FOR CONSTRUCTION SITES #1060.
10. STAGE CONSTRUCTION GRADING ACTIVITIES TO MINIMIZE THE CUMMULATIVE EXPOSED CONDUCT TEMPORARY GRADING FOR EROSION CONTROL PER WDNR TECHNICAL STANDARD TEMPORARY GRADING PRACTICES FOR EROSION CONTROL #1067.
11. PERMITTING OF GROUNDWATER DEWATERING IS THE RESPONSIBILITY OF THE CONTRACTOR. GROUNDWATER DEWATERING IS SUBJECT TO A DNR WASTEWATER DISCHARGE PERMIT AND A DNR HIGH CAPACITY WELL APPROVAL IF CUMULATIVE PUMP CAPACITY IS 70 GPM OR MORE. (REV. FEBRUARY 2017)
12. PROVIDE ANTI-SCOUR PROTECTION AND MAINTAIN NON-EROSIVE FLOW DURING DEWATERING. PERFORM DEWATERING OF ACCUMULATED SURFACE RUNOFF IN ACCORDANCE WITH WDNR TECHNICAL STANDARD DE-WATERING #1061 (REV. FEBRUARY 2017)
13. COMPLETE AND STABILIZE SEDIMENT BASINS/TRAPS OR WET PONDS PRIOR TO MASS LAND DISTURBANCE TO CONTROL RUNOFF DURING CONSTRUCTION. REMOVE SEDIMENT AS NEEDED TO MAINTAIN 3 FEET OF DEPTH TO THE OUTLET, AND PROPERLY DISPOSE OF SEDIMENT REMOVED DURING MAINTENANCE (REFER TO NR 528). CONSTRUCT AND MAINTAIN THE SEDIMENT BASIN PER WDNR TECHNICAL STANDARD SEDIMENT BASIN #1064 AND SEDIMENT TRAP # 1063.
14. CONSTRUCT AND PROTECT THE BIOINFILTRATION BASIN AND VEGETATION FROM RUNOFF AND SEDIMENT DURING CONSTRUCTION. REFERENCE THE WDNR TECHNICAL STANDARD BIORETENTION FOR INFILTRATION # 1004.
15. INSTALL AND MAINTAIN SILT FENCING PER WDNR TECHNICAL STANDARD SILT FENCE REMOVE SEDIMENT FROM BEHIND SILT FENCES AND SEDIMENT BARRIERS BEFORE SEDIMENT REACHES A DEPTH THAT IS EQUAL TO ONE-HALF OF THE FENCE AND/OR BARRIER HEIGHT.
16. REPAIR BREAKS AND GAPS IN SILT FENCES AND BARRIERS IMMEDIATELY. REPLACE DECOMPOSING STRAW BALES (TYPICAL BALE LIFE IS 3 MONTHS). LOCATE, INSTALL, AND MAINTAIN STRAW BALES PER WDNR TECHNICAL STANDARD DITCH CHECKS #1062.
17. INSTALL AND MAINTAIN FILTER SOCKS IN ACCORDANCE WITH WDNR TECHNICAL STANDARD INTERIM MANUFACTURED PERIMETER CONTROL AND SLOPE INTERRUPTION PRODUCTS # 1071.
18. IMMEDIATELY STABILIZE STOCKPILES AND SURROUND STOCKPILES AS NEEDED WITH SILT FENCE OR OTHER PERIMETER CONTROL IF STOCKPILES WILL REMAIN INACTIVE FOR 7 DAYS OR LONGER.
19. IMMEDIATELY STABILIZE ALL DISTURBED AREAS THAT WILL REMAIN INACTIVE FOR 14 DAYS OR LONGER. BETWEEN SEPTEMBER 15 AND OCTOBER 15: STABILIZE WITH MULCH, TACKIFIER, AND A PERENNIAL SEED MIXED WITH WINTER WHEAT, ANNUAL OATS, OR ANNUAL RYE, AS APPROPRIATE FOR REGION AND SOIL TYPE. OCTOBER 15 THROUGH COLD WEATHER: STABILIZE WITH A POLYMER AND DORMANT SEED MIX, AS APPROPRIATE FOR REGION AND SOIL TYPE.
20. STABILIZE AREAS OF FINAL GRADING WITHIN 7 DAYS OF REACHING FINAL GRADE.
21. SWEEP/CLEAN UP ALL SEDIMENT/TRASH THAT MOVES OFF-SITE DUE TO CONSTRUCTION ACTIVITY OR STORM EVENTS BEFORE THE END OF THE SAME WORKDAY. SEPARATE SWEEP MATERIALS (SOILS AND TRASH) AND DISPOSE OF APPROPRIATELY.
22. THE CONTRACTOR IS RESPONSIBLE FOR CONTROLLING DUST PER WDNR TECHNICAL STANDARD DUST CONTROL ON CONSTRUCTION SITES # 1068.
23. PROPERLY DISPOSE OF ALL WASTE AND UNUSED BUILDING MATERIALS (INCLUDING GARBAGE, DEBRIS, CLEANING WASTES, OR OTHER CONSTRUCTION MATERIALS) AND DO NOT ALLOW THESE MATERIALS TO BE CARRIED BY RUNOFF INTO THE RECEIVING CHANNEL.
24. THE CONTRACTOR IS RESPONSIBLE FOR UPDATING THE LAND DISTURBANCE PERMIT TO INDICATE THE ANTICIPATED OR LIKELY DISPOSAL LOCATIONS FOR ANY EXCAVATED SOILS OR CONSTRUCTION DEBRIS THAT WILL BE HAULED OFF-SITE FOR DISPOSAL. THE DEPOSITED OR STOCKPILED MATERIAL NEEDS TO INCLUDE PERIMETER SEDIMENT CONTROL MEASURES (SUCH AS SILT FENCE, HAY BALES, FILTER SOCKS, OR COMPACTED EARTHEN BERMS).
25. FOR NON-CHANNELIZED FLOW ON DISTURBED OR CONSTRUCTED SLOPES, PROVIDE CLASS I TYPE A EROSION CONTROL MATTING. SELECT EROSION MATTING FROM APPROPRIATE MATRIX IN WISDOT'S WIDOT PRODUCT ACCEPTABILITY LIST (PAL); INSTALL AND MAINTAIN PER WDNR TECHNICAL STANDARD NON-CHANNEL EROSION MAT #1052.
26. FOR CHANNELIZED FLOW ON DISTURBED OR CONSTRUCTED AREAS, PROVIDE CLASS I TYPE B EROSION CONTROL MATTING. SELECT EROSION MATTING FROM APPROPRIATE MATRIX IN WISDOT'S WIDOT PRODUCT ACCEPTABILITY LIST (PAL); INSTALL AND MAINTAIN PER WDNR TECHNICAL STANDARD CHANNEL EROSION MAT #1053.
27. MAKE PROVISIONS FOR WATERING DURING THE FIRST 8 WEEKS FOLLOWING SEEDING OR PLANTING OF DISTURBED AREAS WHENEVER MORE THAN 7 CONSECUTIVE DAYS OF DRY WEATHER OCCUR.
28. THE CONTRACTOR IS RESPONSIBLE FOR COMPLYING WITH ALL APPLICABLE WDNR REMEDIATION AND WASTE MANAGEMENT REQUIREMENTS FOR HANDLING AND DISPOSING OF CONTAMINATED MATERIALS. SITE SPECIFIC INFORMATION FOR AREAS WITH KNOWN OR SUSPECTED SOIL AND/OR GROUNDWATER CONTAMINATION CAN BE FOUND ON WDNR'S BUREAU OF REMEDIATION AND REDEVELOPMENT TRACKING SYSTEM (BRRTS) PUBLIC DATABASE AT: [HTTP://DNR.WI.GOV/BOTW/](http://dnr.wi.gov/botw/)
29. THE CONTRACTOR IS RESPONSIBLE FOR PROVIDING A SPILL PLAN. REFER TO THIS DOCUMENT IF THERE IS A DISCHARGE OF SEDIMENT AND/OR OTHER CONTAMINANTS. A SPILL PLAN IS REQUIRED IF THERE IS POTENTIAL TO DISCHARGE CONTAMINANTS TO WATERS OF THE STATE.
30. THE CONTRACTOR IS RESPONSIBLE FOR PROVIDING A FRAC OUT PLAN IF DRILLING IS TO OCCUR. REFER TO THIS DOCUMENT IF AN INADVERTANT DISCHARGE OF DRILLING FLUIDS ("FRAC OUT") OCCURS. A SPILL PLAN IS REQUIRED IF THERE IS POTENTIAL TO DISCHARGE CONTAMINANTS TO WATERS OF THE STATE.
31. INSTALL AND MAINTAIN A CONCRETE WASHOUT BASIN PER EPA 833-F-11-006: [HTTPS://WWW3.EPA.GOV/NPDES/PUBS/CONCRETEWASHOUT.PDF](https://www3.epa.gov/npdes/pubs/concretewashout.pdf). REQUIRE USE BY ALL CONCRETE CONTRACTORS. LIQUID MAY BE REUSED IN CONCRETE MIXING, EVAPORATED, OR DISPOSED OF AS WASTEWATER.



SHEET NOT VALID UNLESS THIS TEXT IS COLOR.

THIS DOCUMENT IS THE PROPERTY OF I & S GROUP, INC. AND MAY NOT BE USED, COPIED OR DUPLICATED WITHOUT PRIOR WRITTEN CONSENT.
© 2024 I & S GROUP, INC.

PROJECT

**BORTON
CONSTRUCTION
NEW OFFICE**

LA CROSSE WISCONSIN

REVISION SCHEDULE		
DATE	DESCRIPTION	BY

PROJECT NO.	26-34320
FILE NAME	34320 C1-SWPPP
DRAWN BY	AAE
DESIGNED BY	AAE
REVIEWED BY	KBR
ORIGINAL ISSUE DATE	06/05/2026
CLIENT PROJECT NO.	-

TITLE

SWPPP NARITIVE

SHEET

C1-11

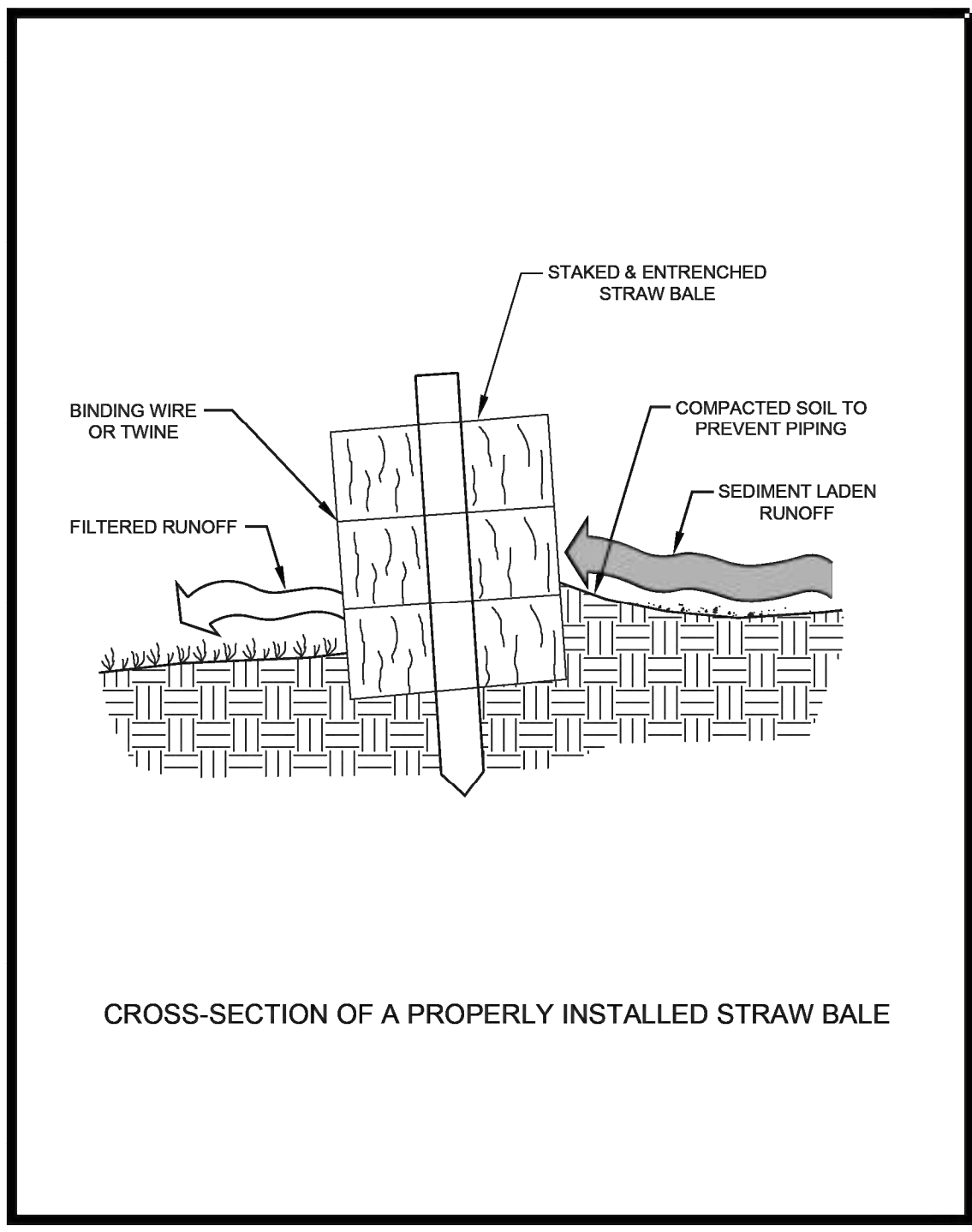
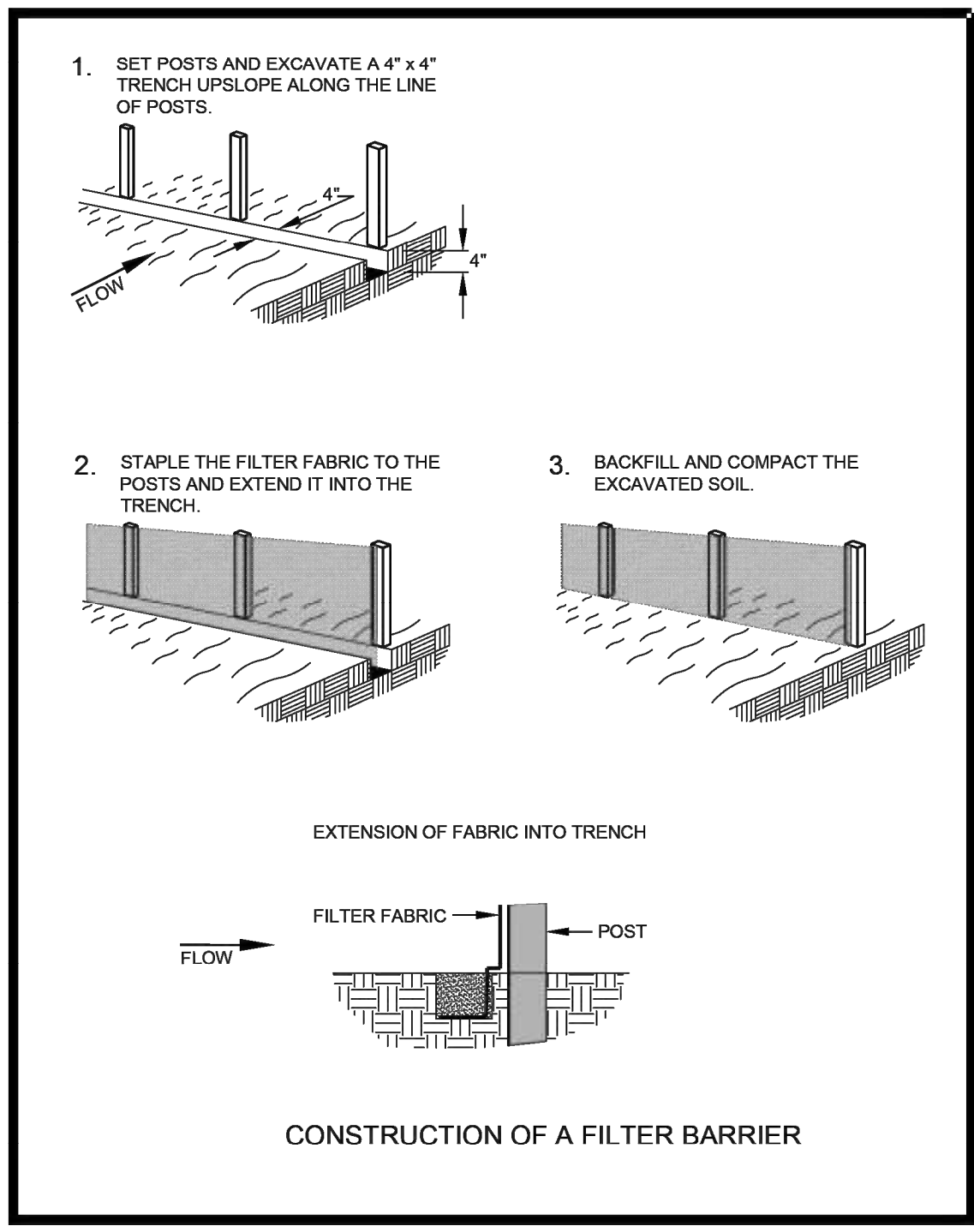
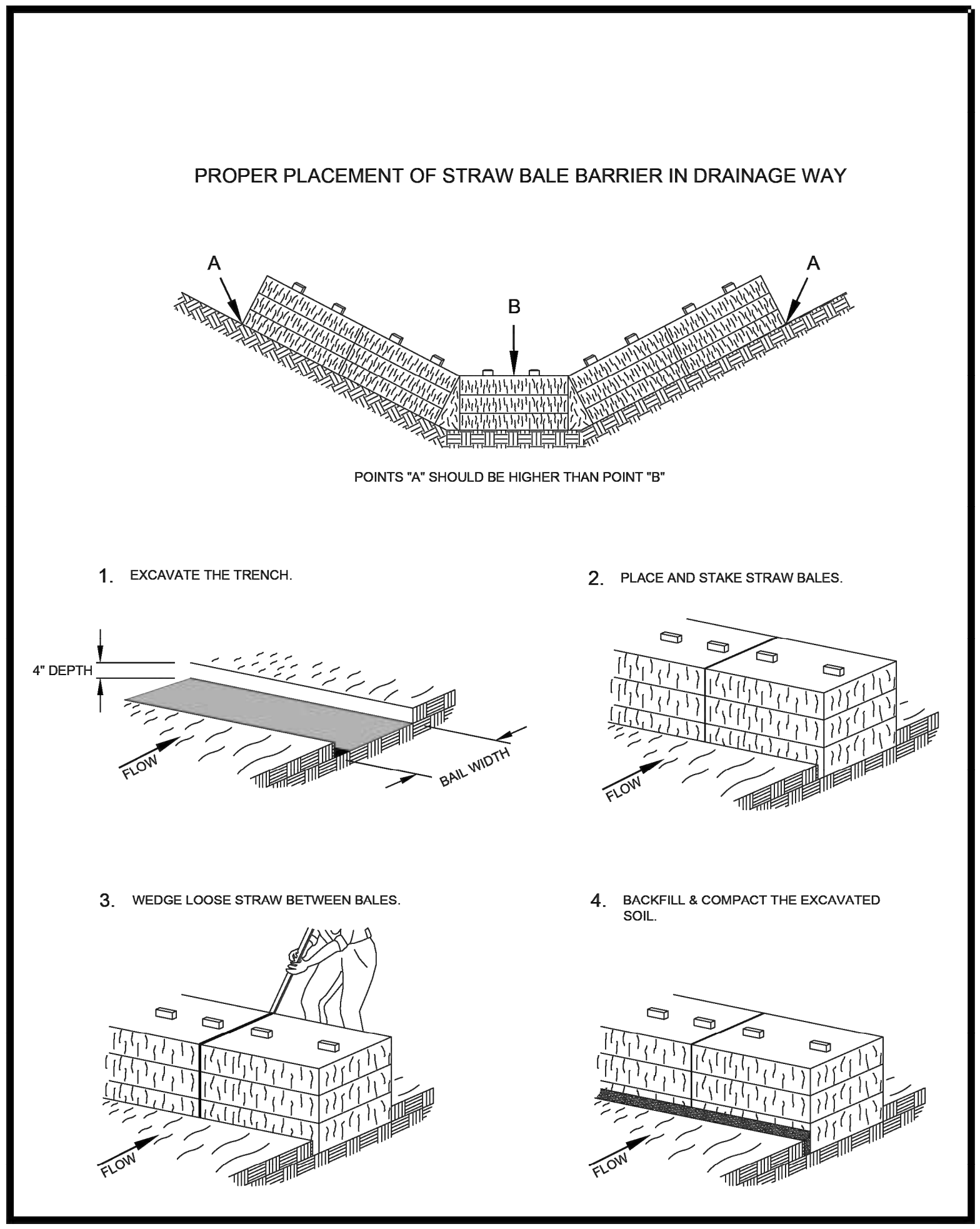
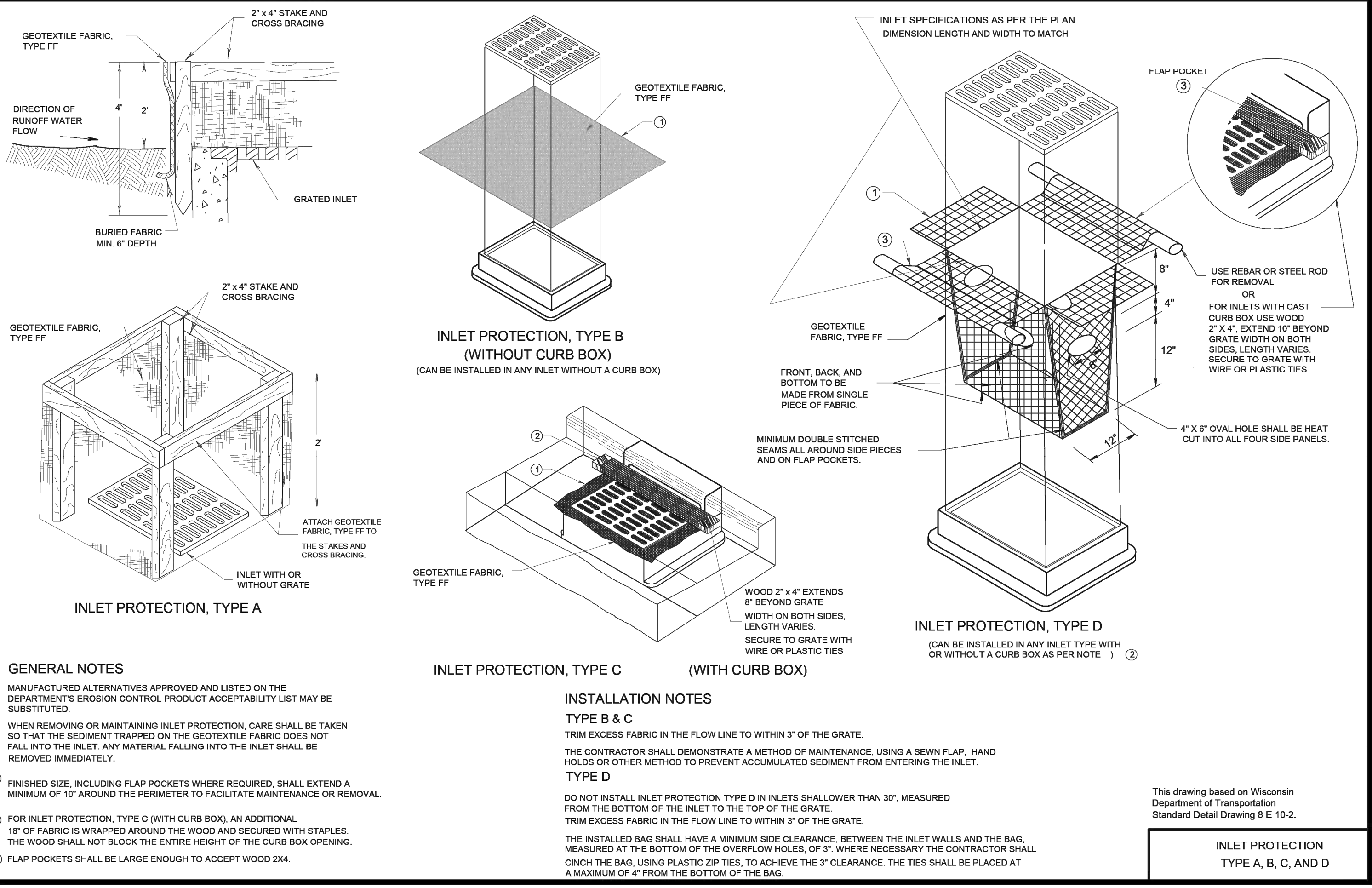
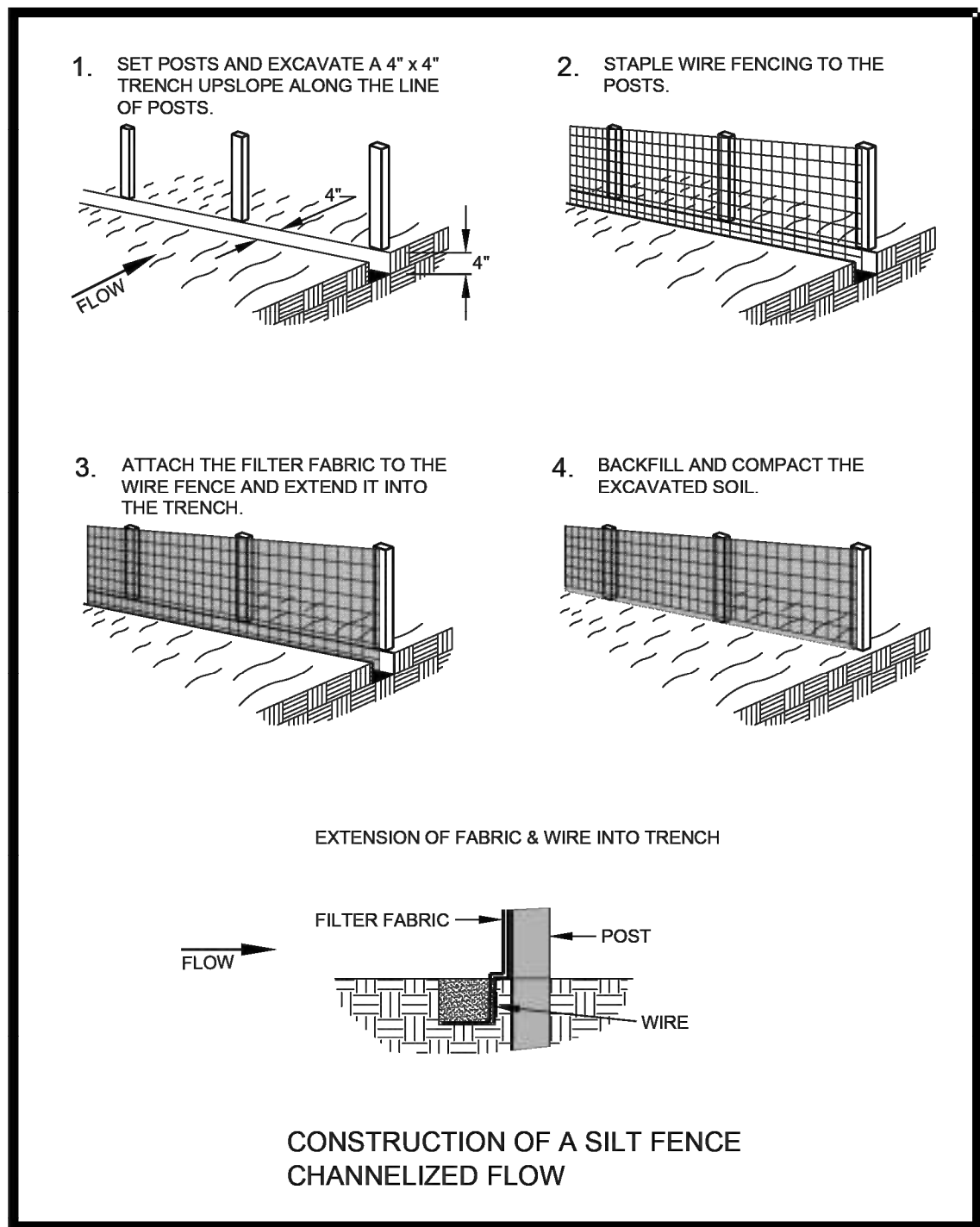

EDF #	DWG NAME: EROSION-CONTROL-DWG		
PROJECT No.	EROSION CONTROL DETAILS		
LOCATION	D-1-2		
RESOLUTION	DATE		
ENGINEERING DEPT. City of La Crosse, Wis.			
FIELD BOOK	SURVEYED	BY	DATE
NUMBER	DRAWN	PRELIMINARY	
	CHECKED	FINAL	JMC 2/2009
PAGE	APPROVED		
	REVISIONS		
SHEET NO.	TOTAL SHEETS		

SHEET NOT VALID UNLESS THIS TEXT IS COLOR.

THIS DOCUMENT IS THE PROPERTY OF I & S GROUP, INC. AND MAY NOT BE USED, COPIED OR DUPLICATED WITHOUT PRIOR WRITTEN CONSENT.
© 2024 I & S GROUP, INC.

PROJECT
BORTON CONSTRUCTION
NEW OFFICE

LA CROSSE WISCONSIN

REVISION SCHEDULE		
DATE	DESCRIPTION	BY

PROJECT NO. 26-34320
FILE NAME 34320 C1-SWPPP
DRAWN BY AAE
DESIGNED BY AAE
REVIEWED BY KBR
ORIGINAL ISSUE DATE 06/05/2026
CLIENT PROJECT NO. -

TITLE

SWPPP DETAILS

SHEET

C1-12



EROSION CONTROL LEGEND

SYMBOL	DESCRIPTION
	SILT FENCE, PREASSEMBLED
	ROCK CONSTRUCTION EXIT
	CONCRETE WASHOUT AREA
	EXISTING DRAINAGE ARROW
	EXISTING CONTOUR (MINOR INTERVAL)
	EXISTING CONTOUR (MAJOR INTERVAL)

PERIMETER CONTROL CAN BE SILT FENCE OR SEDIMENT CONTROL LOG.
 NOTE: EROSION CONTROL PLAN COVERAGE INCLUDES ELECTRIC, GAS, TELEPHONE, AND CABLE INSTALLATION. EACH COMPANY OR THEIR SUBCONTRACTOR IS RESPONSIBLE TO FOLLOW THE REQUIREMENTS OF THIS PLAN, INCLUDING PROVIDING THEIR OWN RESTORATION IF INSTALLATION OCCURS AFTER PRIMARY INSTALLATION OF SEEDING/SODDING/MULCHING DURING CONSTRUCTION OF EACH UTILITY.

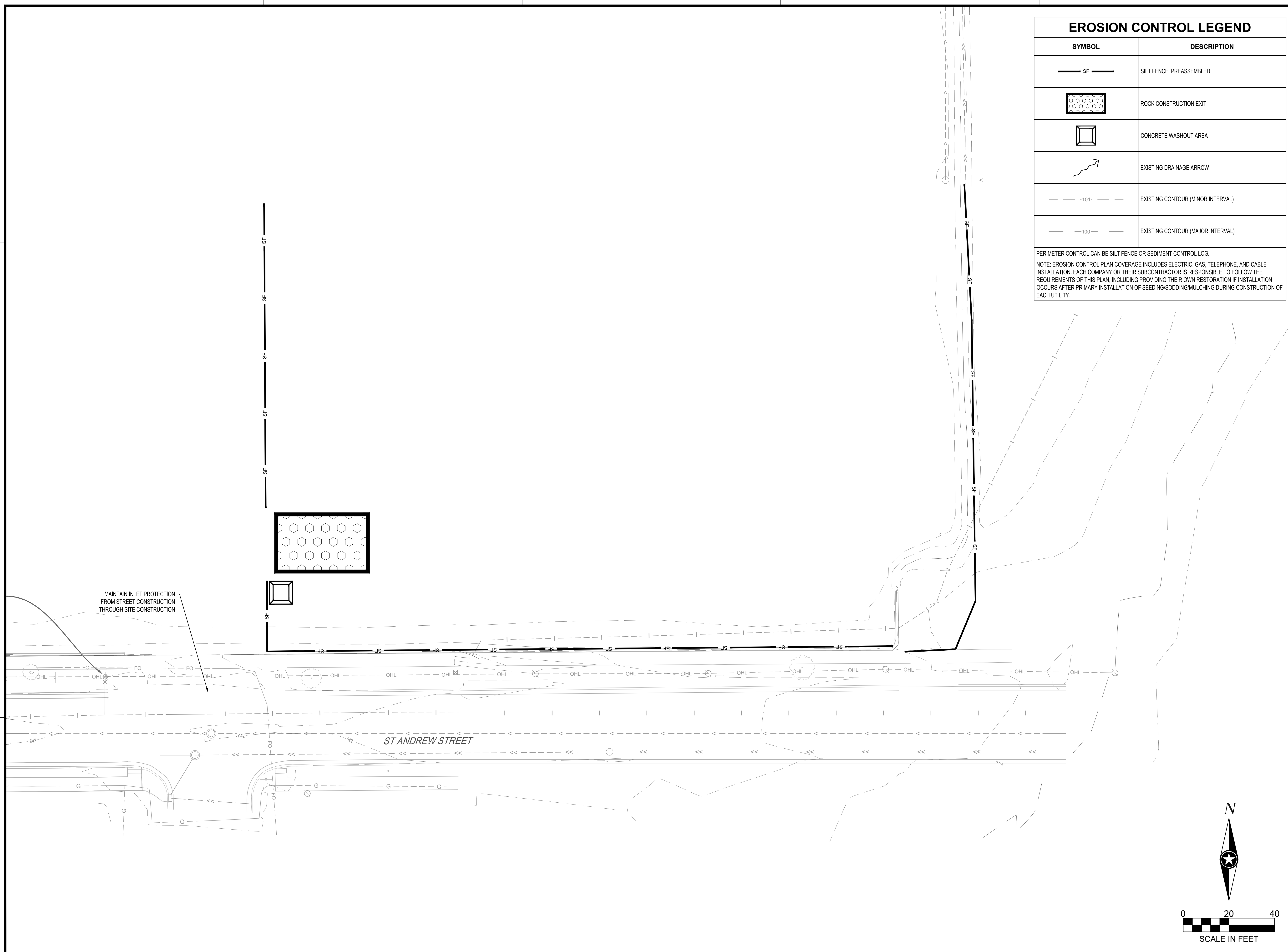

SHEET NOT VALID UNLESS THIS TEXT IS COLOR.

THIS DOCUMENT IS THE PROPERTY OF I & S GROUP, INC. AND MAY NOT BE USED, COPIED OR DUPLICATED WITHOUT PRIOR WRITTEN CONSENT.
 © 2024 I & S GROUP, INC.

PROJECT

**BORTON
 CONSTRUCTION
 NEW OFFICE**

LA CROSSE WISCONSIN

REVISION SCHEDULE

DATE	DESCRIPTION	BY

PROJECT NO. 26-34320

FILE NAME 34320 C1-SWPPP

DRAWN BY AAE

DESIGNED BY AAE

REVIEWED BY KBR

ORIGINAL ISSUE DATE 06/05/2026

CLIENT PROJECT NO. -

TITLE

**PRE
 CONSTRUCTION
 SWPPP**

SHEET

C1-13

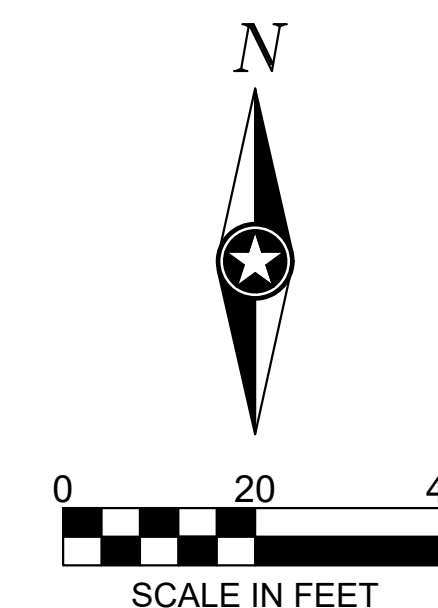

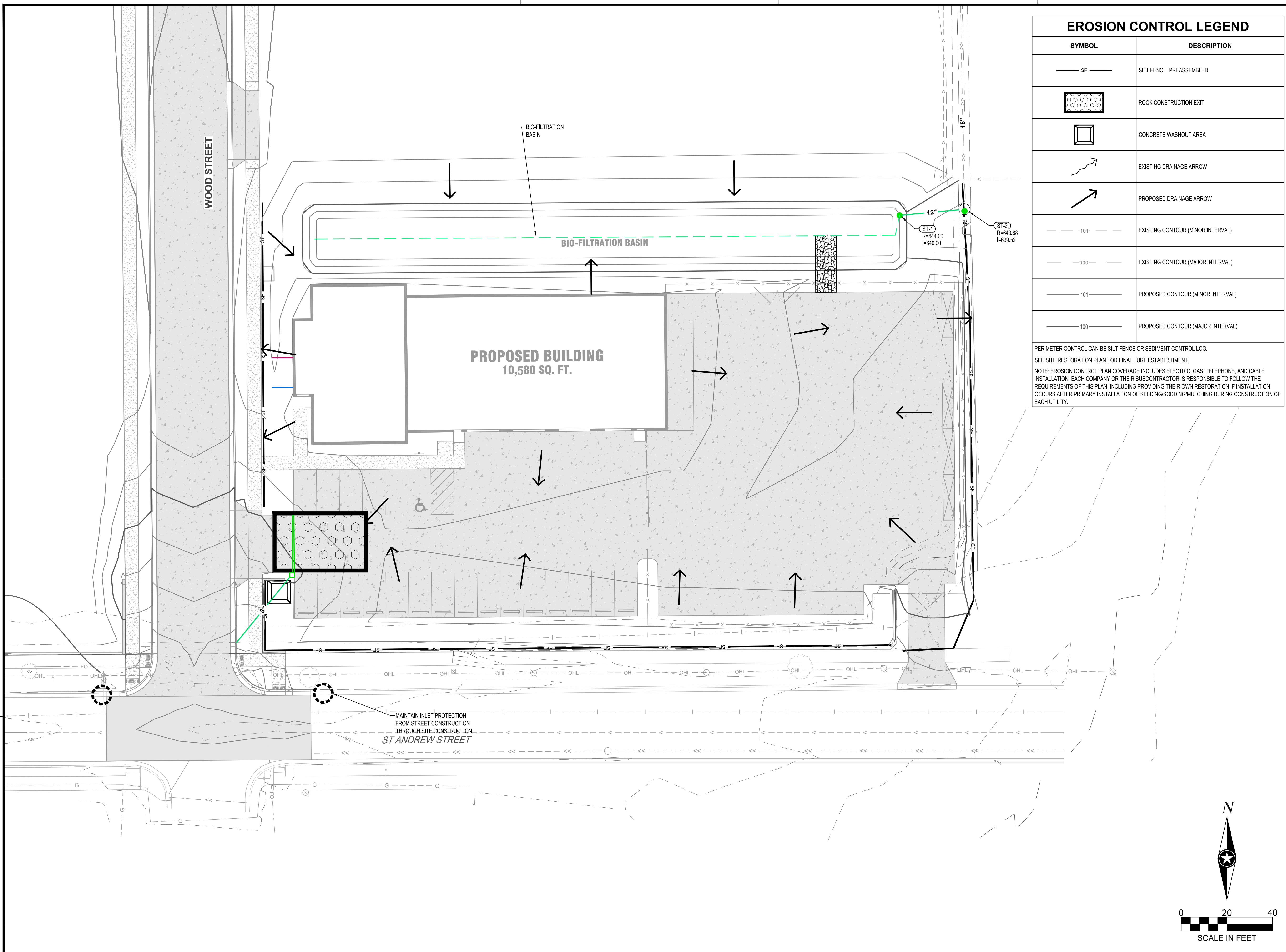

EROSION CONTROL LEGEND	
SYMBOL	DESCRIPTION
	SILT FENCE, PREASSEMBLED
	ROCK CONSTRUCTION EXIT
	CONCRETE WASHOUT AREA
	EXISTING DRAINAGE ARROW
	PROPOSED DRAINAGE ARROW
	EXISTING CONTOUR (MINOR INTERVAL)
	EXISTING CONTOUR (MAJOR INTERVAL)
	PROPOSED CONTOUR (MINOR INTERVAL)
	PROPOSED CONTOUR (MAJOR INTERVAL)

PERIMETER CONTROL CAN BE SILT FENCE OR SEDIMENT CONTROL LOG.
 SEE SITE RESTORATION PLAN FOR FINAL TURF ESTABLISHMENT.
 NOTE: EROSION CONTROL PLAN COVERAGE INCLUDES ELECTRIC, GAS, TELEPHONE, AND CABLE INSTALLATION. EACH COMPANY OR THEIR SUBCONTRACTOR IS RESPONSIBLE TO FOLLOW THE REQUIREMENTS OF THIS PLAN, INCLUDING PROVIDING THEIR OWN RESTORATION IF INSTALLATION OCCURS AFTER PRIMARY INSTALLATION OF SEEDING/SODDING/MULCHING DURING CONSTRUCTION OF EACH UTILITY.



SHEET NOT VALID UNLESS THIS TEXT IS COLOR.
 THIS DOCUMENT IS THE PROPERTY OF I & S GROUP, INC. AND MAY NOT BE USED, COPIED OR DUPLICATED WITHOUT PRIOR WRITTEN CONSENT.
 © 2024 I & S GROUP, INC.

PROJECT
**BORTON
 CONSTRUCTION
 NEW OFFICE**

LA CROSSE WISCONSIN

REVISION SCHEDULE		
DATE	DESCRIPTION	BY

PROJECT NO.	26-34320
FILE NAME	34320 C1-SWPPP
DRAWN BY	AAE
DESIGNED BY	AAE
REVIEWED BY	KBR
ORIGINAL ISSUE DATE	06/05/2026
CLIENT PROJECT NO.	-

TITLE
**POST
 CONSTRUCTION
 SWPPP**

SHEET
C1-14

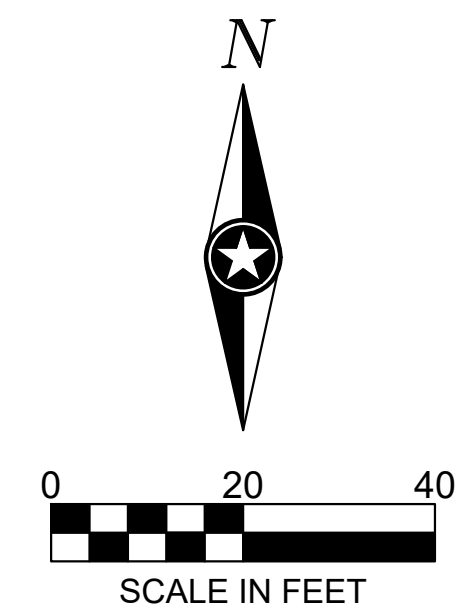

2
55,437 SQ FT
1.27 AC

PAVEMENT LEGEND	
SYMBOL	DESCRIPTION
	HEAVY DUTY CONCRETE PAVEMENT
	CONCRETE WALK
	STANDARD CURB AND GUTTER

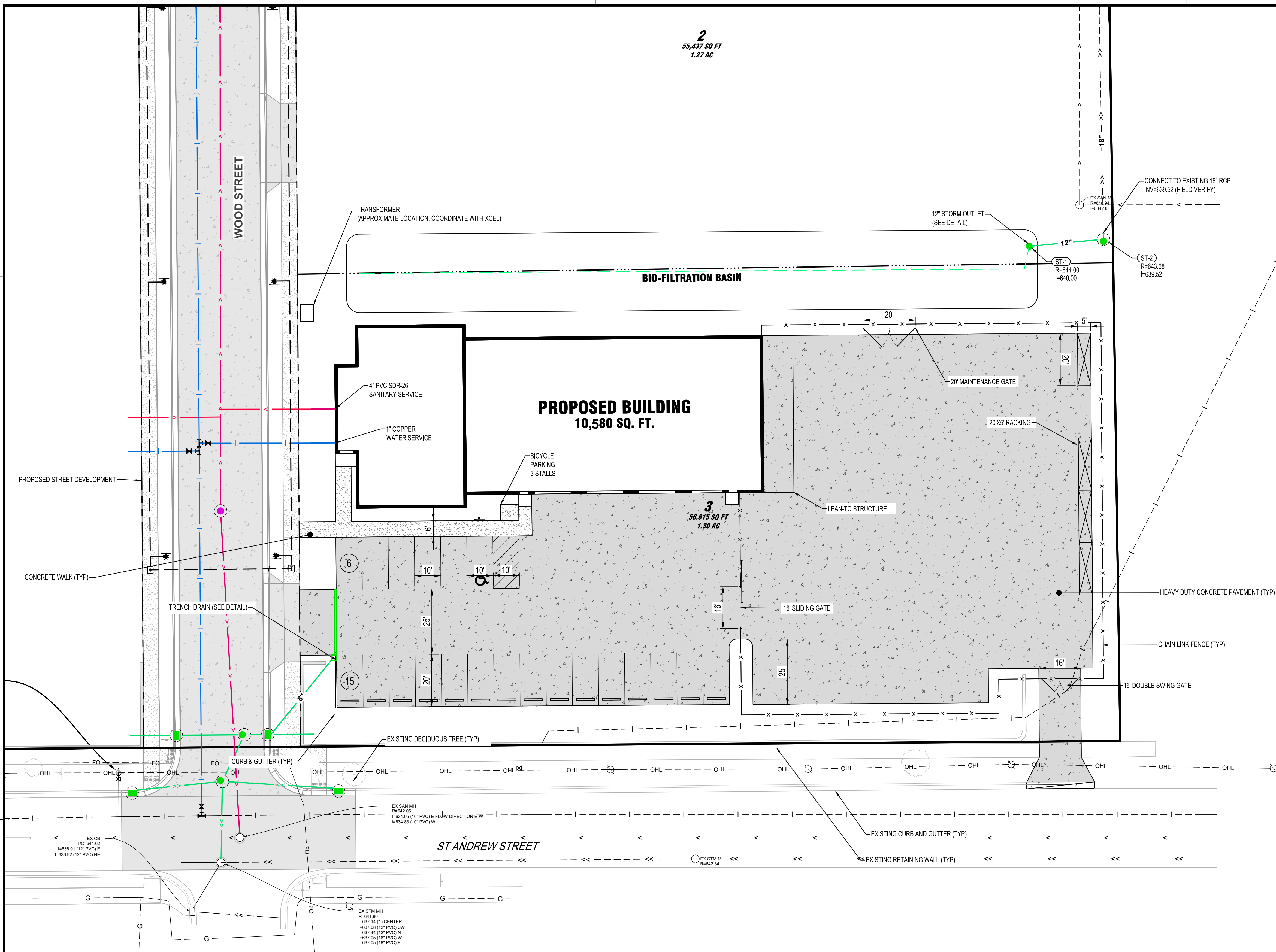

SHEET NOT VALID UNLESS THIS TEXT IS COLOR.

THIS DOCUMENT IS THE PROPERTY OF I & S GROUP, INC. AND MAY NOT BE USED, COPIED OR DUPLICATED WITHOUT PRIOR WRITTEN CONSENT. © 2024 I & S GROUP, INC.

PROJECT
BORTON CONSTRUCTION
NEW OFFICE

LA CROSSE WISCONSIN

REVISION SCHEDULE		
DATE	DESCRIPTION	BY

PROJECT NO.	26-34320
FILE NAME	34320 C3-SITE
DRAWN BY	AAE
DESIGNED BY	AAE
REVIEWED BY	KBR
ORIGINAL ISSUE DATE	06/05/2026
CLIENT PROJECT NO.	-

TITLE
SITE AND UTILITY PLAN

SHEET
C3-10

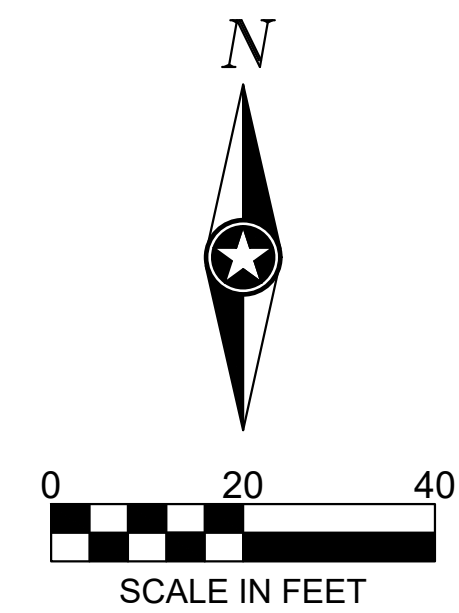

2
55,437 SQ FT
1.27 AC

WOOD STREET

BIO-FILTRATION BASIN

PROPOSED BUILDING
10,580 SQ. FT.
FFE=647.5

3
56,815 SQ FT
1.30 AC

ST ANDREW STREET

GRADING LEGEND

	EXISTING CONTOUR (MINOR INTERVAL)
	EXISTING CONTOUR (MAJOR INTERVAL)
	PROPOSED CONTOUR (MINOR INTERVAL)
	PROPOSED CONTOUR (MAJOR INTERVAL)
	PROPOSED SPOT ELEVATION
	PROPOSED TOP BACK OF CURB / TOP OF TURNDOWN WALK SPOT ELEVATION
	PROPOSED TOP OF RETAINING WALL (TW) AND FINISHED GRADE (FG) AT BOTTOM OF RETAINING WALL
	SURFACE GRADE / DIRECTION

GENERAL GRADING NOTES

PROPOSED CONTOURS SHOW FINISHED GRADE ELEVATIONS. BUILDING PAD AND PAVEMENT HOLD DOWNS ARE NOT INCLUDED. WHEN CONSTRUCTING BUILDING PADS WITH A HOLD DOWN, GRADE AREAS TO ENSURE POSITIVE BUILDING PAD DRAINAGE.



SHEET NOT VALID UNLESS THIS TEXT IS COLOR.

THIS DOCUMENT IS THE PROPERTY OF I & S GROUP, INC. AND MAY NOT BE USED, COPIED OR DUPLICATED WITHOUT PRIOR WRITTEN CONSENT.
© 2024 I & S GROUP, INC.

PROJECT

**BORTON
CONSTRUCTION
NEW OFFICE**

LA CROSSE WISCONSIN

REVISION SCHEDULE		
DATE	DESCRIPTION	BY

PROJECT NO. 26-34320
FILE NAME 34320 C4-GRAD
DRAWN BY AAE
DESIGNED BY AAE
REVIEWED BY KBR
ORIGINAL ISSUE DATE 06/05/2026
CLIENT PROJECT NO. -

TITLE

GRADING PLAN

SHEET

C4-10

