



City of La Crosse, Wisconsin

City Hall
400 La Crosse Street
La Crosse, WI 54601

Meeting Agenda - Final

Board of Public Works

Monday, December 9, 2024

10:00 AM

Council Chambers
City Hall, First Floor

The Board of Public Works meeting is open for in-person attendance and will also be conducted through video conferencing. The meeting can be viewed by visiting the Legislative Information Center (<https://cityoflacrosse.legistar.com/Calendar.aspx>) and clicking on the video link to the far right in the meeting list.)

Call to Order

Roll Call

Mitch Reynolds, Tamra Dickinson, Rebecca Schwarz, Andrea Trane, Matthew Gallager.

Approval of Minutes

Minutes from December 2, 2024.

Agenda Items:

- [24-1535](#) Construction Contract Change Orders.
- [24-1552](#) CNS Networks, LLC on behalf of Brightspeed request for date extension of Temporary Street Privilege Permit application in existing conduit at 700 3rd St S and various locations.
- [24-1553](#) CNS Networks, LLC on behalf of Brightspeed request for date extension of Temporary Street Privilege Permit application for Copeland Ave/Causeway Blvd.
- [24-1556](#) Presentation of revisions to City of La Crosse Standard Specifications and Procedures and Detail Drawings.

Adjournment

Notice is further given that members of other governmental bodies may be present at the above scheduled meeting to gather information about a subject over which they have decision-making responsibility.

NOTICE TO PERSONS WITH A DISABILITY

Requests from persons with a disability who need assistance to participate in this meeting should call the City Clerk's office at (608) 789-7510 or send an email to ADAcityclerk@cityoflacrosse.org, with as much advance notice as possible.



City of La Crosse, Wisconsin

City Hall
400 La Crosse Street
La Crosse, WI 54601

Text File

File Number: 24-1535

Agenda Date: 12/9/2024

Version: 1

Status: Agenda Ready

In Control: Board of Public Works

File Type: General Item

CONTRACT CHANGE ORDER

No. 3

Date 11/27/2024

EDF # 23-005

Contract No. Curb-2024-003 for the following public work: Hass St – Losey Blvd. to Diagonal Rd. between Fowler & Hammer, Inc. and the City of La Crosse, dated 02/08/2024, is hereby changed in the following particulars, to-wit:

The following specific work is hereby eliminated from such contract:

N/A

The following specific work is hereby added to such contract:

Additional Earthwork Time & Materials

By virtue of such changes in the contract, the following revisions shall be made:

Contract -----	<u>\$545,971.87</u>
Contingency -----	<u>\$ 52,501.08</u>
Net Previous Change Orders -----	<u>\$ 12,858.92</u>
Decrease by eliminations (this C.O.) -----	<u>\$0.00</u>
Increase by additions (this C.O.) -----	<u>\$8,050.00</u>
Net Deductions or Additions (Strike out one) -----	<u>\$ 8,050.00</u>
Revised Contract Total -----	<u>\$566,880.79</u>

Fowler & Hammer, Inc

NAME OF CONTRACTOR

 PM
CONTRACTOR SIGNATURE

BOARD OF PUBLIC WORKS

I HEREBY CERTIFY that there are sufficient funds in the treasury to meet the liability assumed by the foregoing addenda to contract, or that provision has been made to pay the liability that will accrue thereunder. (WS 62.15-12; 62.09-10-f)

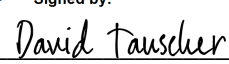
Signed by:

EE923CC8B4BC443... **Budget Analyst**

DocuSigned by:

A93F306A40954A6... **Controller**

CONTRACT CHANGE ORDER

No. 1

Date 12/4/2024

EDF # 23-006

Contract No. MISC-2024-004 for the following public work: 2023 Signal Fiber Southside Infill between Kramer Well Drilling and the City of La Crosse, dated February 8, 2024, is hereby changed in the following particulars, to-wit:

The following specific work is hereby eliminated from such contract:

Fiber to 16th & Jackson \$ 33,049.60

The following specific work is hereby added to such contract:

Duct cleaning on Mormon Coulee Rd, \$15,575.00

West Ave, and Main St

Duct repair on Mormon Coulee Rd, \$24,803.20

West Ave, and La Crosse St

Additional Drilling on Ward Ave \$ 5,489.36

By virtue of such changes in the contract, the following revisions shall be made:

Contract-----	\$ 309,922.24
Contingency-----	\$ 40,077.76
Net Previous Change Orders-----	\$ _____
Decrease by eliminations (this C.O.)-----	\$ 33,049.60
Increase by additions (this C.O.)-----	\$ 40,378.20
Net Deductions or Additions (Strike out one)-----	\$ 7,328.60
Revised Contract Total -----	\$ 317,250.84

Kramer Well Drilling
NAME OF CONTRACTOR

COO / 12-4-24
CONTRACTOR SIGNATURE

BOARD OF PUBLIC WORKS

I HEREBY CERTIFY that there are sufficient funds in the treasury to meet the liability assumed by the foregoing addenda to contract, or that provision has been made to pay the liability that will accrue thereunder. (WS 62.15-12; 62.09-10-f)

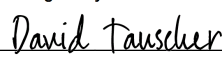
Signed by:

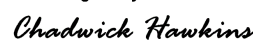
EE923CC8B4BC443... Budget Analyst

DocuSigned by:

A93F306A40954A6... Controller



City of La Crosse, Wisconsin

City Hall
400 La Crosse Street
La Crosse, WI 54601

Text File

File Number: 24-1552

Agenda Date: 12/9/2024

Version: 1

Status: Agenda Ready

In Control: Board of Public Works

File Type: General Item



APPROVED TEMPORARY STREET PRIVILEGE PERMIT
Engineering Dept. • Phone: (608) 789-7505 • Fax: (608) 789-8184
http://www.cityoflacrosse.org engineering@cityoflacrosse.org

Permit No: 2024-061-03
Date: 05/14/2024
Parcel ID:

STATUS: _____ Permit Type: TSP

Name: CNS Networks, LLC on behalf of Brightspeed
Address: 1600 Pearl #300
City: Boulder State: CO Zip Code: 80302
Phone: Cell: 920-344-2687 Fax: Email: fwoznick@congruex.com
Vehicle License Number (If Applicable): Tag #:

Location: 700 3rd St and various locations
Area to be occupied: X Traffic Lane(s) X Parking Lane(s) Boulevard Sidewalk Alley X
Purpose for permit: Fiber optic upgrade of existing conduit - total path 19,720
Additional Conditions:

Start Date: 6/17/24 End Date: 7/5/24

Invoice #: RWP-050918-2024 Fee: \$ TRD (\$35.00 first 5 days, \$2.00 each additional day)

Permit issued by: [Signature] BPW 24-0802 - 6/17/24

Comments:
• Will notify Engineering minimum 24-hours in advance of flagging operations located at signalized intersections.
BPW 24-105 - 7/22/24
BPW 24-1015-7/22/24 MB
7/1/24 - extension from 7/6 - 7/20/24 - After that, approval from BPW will be needed
7/22 - extension from 7/20 - 8/3/24

The undersigned understands and agrees to the following: 1) The permitted work shall comply with all permit provisions and conditions listed on and attached to this form; 2) That insurance requirements shall be met prior to approval either by submitting information with application or by keeping current information on file with the Engineering Dept.; 3) The applicant shall contact City Dispatch and the City Traffic Engineer 24 hours prior to the closure of any traffic lanes and shall provide an estimate of the duration of the closure. Temporary traffic control shall be provided and maintained by the applicant and shall comply with Part 6 of the Manual on Uniform Traffic Control Devices (MUTCD).

Note: Once invoiced, application fees may not be refunded. Details of permit, including dates, may be modified with approval of the Engineering Department.

Brittany Bruneau
(PRINT) AUTHORIZED REPRESENTATIVE

Permit Specialist
TITLE

05/14/2024
DATE

Brittany Bruneau
(SIGN) AUTHORIZED REPRESENTATIVE

Permit Specialist
TITLE

05/14/2024
DATE

Holland, Michelle

From: Mendoza, Alicia <amendoza@congruex.com>
Sent: Monday, July 15, 2024 3:17 PM
To: Holland, Michelle; Bart, Anthony
Cc: Chwala, Aaron; Stieber, Edward; Pouncil, Shauna; Johnson, Rebekah
Subject: RE: CNS Congruex - BrightSpeed permit extension

*** **CAUTION:** This email originated from an external sender. **DO NOT** click links or open attachments unless you recognize the sender and know the content is safe. ***

Hi Michelle,

Our construction crew has requested an extension for this permit to 8/3.

From: Holland, Michelle <hollandm@cityoflacrosse.org>
Sent: Monday, July 1, 2024 12:42 PM
To: Bart, Anthony <abart@congruex.com>
Cc: Chwala, Aaron <achwala@congruex.com>; Stieber, Edward <estieber@congruex.com>; Mendoza, Alicia <amendoza@congruex.com>; Pouncil, Shauna <spouncil@congruex.com>; Johnson, Rebekah <rejohnson@congruex.com>
Subject: RE: CNS Congruex - BrightSpeed permit extension

CAUTION: This email originated from outside of the organization. Do not click links or open attachments unless you recognize the sender and know the content is safe.

Anthony,

I have extended the permit application for the requested dated of 7/20/24. Please let me know by **07/17/24** if you think you will need another extension past 07/20/24. I know its hard to know for sure but future extensions have to go to the Board of Public Works, so I want to make sure I have time to get them on the agenda for you.

I have also attached the invoices for the permit. There are two invoices. They are split by start/end dates. You can pay them online using the link or you can mail in a check.

[Pay Invoices \(cityoflacrosse.org\)](https://cityoflacrosse.org)

Let me know if you have any questions or if I can help with anything else.

Thank you

Michelle Holland

Administrative Specialist
Engineering & Public Works
City Hall
100 La Crosse St
La Crosse, WI 54601
Office: 608.789.7505

BRIGHTSPEED LA CROSSE

LCRSWIXC
 700 3RD ST N, LA CROSSE, WI 54601, USA
 CONDUIT LAYOUT

Sheet List Table

Sheet Number	Sheet Title
01	COVER SHEET
02	GENERAL NOTES
03	LEGENDS
04	TYPICAL
05-32	FIBER LAYOUTS

Material List Table

ITEM	QUANTITY
FEEDER FIBER	00
JUMPER	00
17"X30"X18" HH	00
12"X24"X18" HH	00
24"X36"X24" HH	00
2" CONDUIT	00
NEW STRAND	00
ANCHOR	00

BLM INFO

SECTION	S32
MUNICIPALITY	LA CROSSE
TOWNSHIP	T16N
COUNTY	LA CROSSE
RANGE	R07W

REVISION	DATE	DESCRIPTION

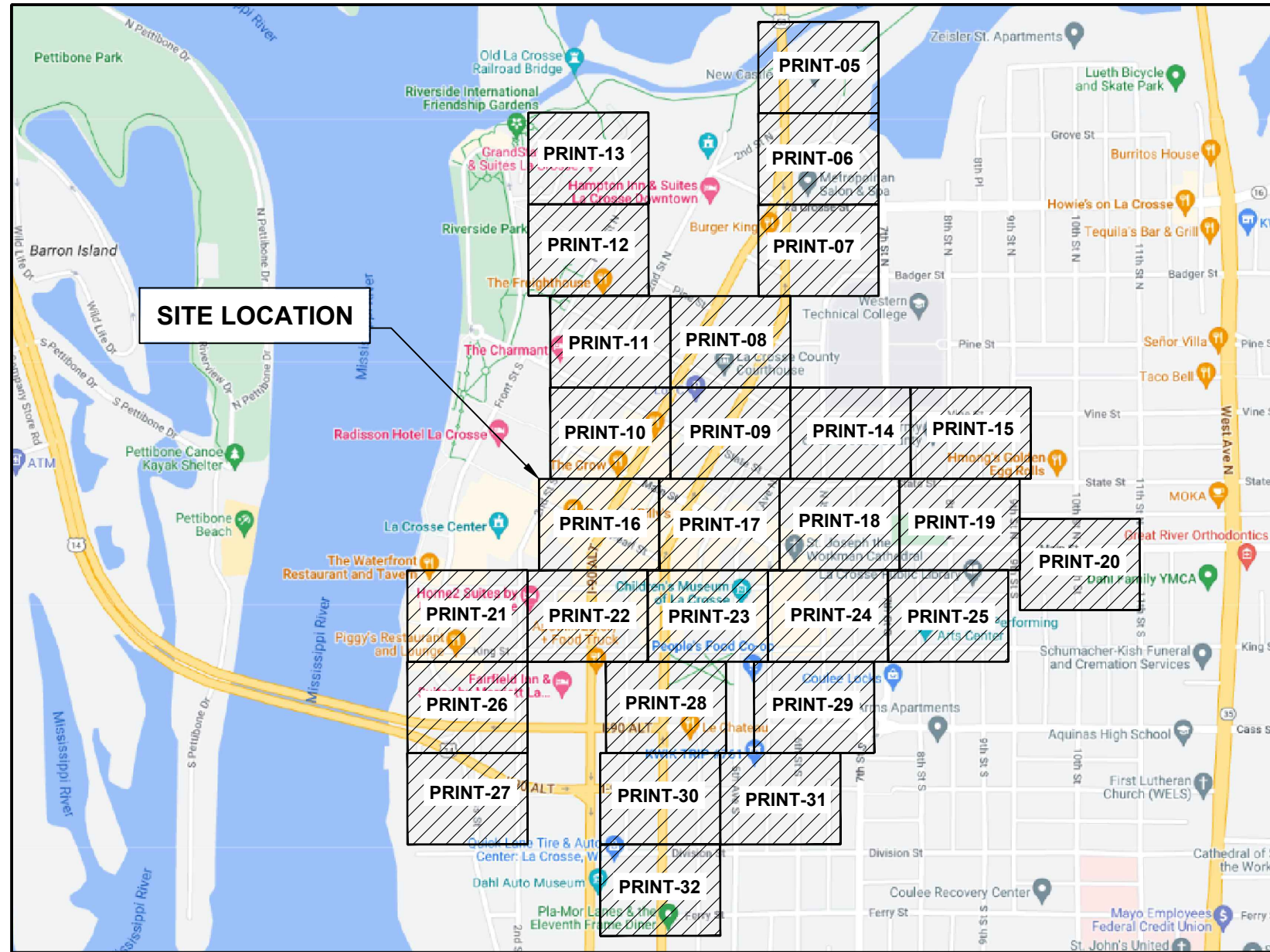

GENERAL ABBREVIATIONS

R/W	RIGHT OF WAY
S/W	SIDEWALK
C/L	CENTER LINE
CSW	CONCRETE SIDEWALK
DWY	DRIVEWAY
FOC	FACE OF CURB
BOC	BACK OF CURB
EOC	EDGE OF CURB
EOP	EDGE OF PAVEMENT
ETW	ETW LINE
HH	HANDHOLE
MH	MANHOLE
N.T.S.	NOT TO SCALE
CONC	CONCRETE
PED	PEDESTAL (UTILITY)
PVC	POLYVINYL CHLORIDE
P/L	PROPERTY LINE
RR	RAILROAD
SL	STREET LIGHT
W-BLDG	WALL TO BUILDING
W-P	WALL TO POLE
W-W	WALL TO WALL
U/E	UTILITY EASEMENT
SD	STORM DRAIN
TS	TRAFFIC SIGNAL

PERMITTING AGENCY
 CITY OF LA CROSSE

PROPOSED LINEAR PATH FOOTAGE
 UG PATH - 19,720 FT

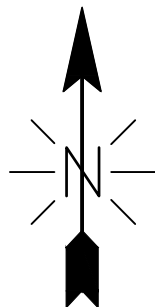

Know what's below.
 Call before you dig.



CONFIDENTIAL AND PROPRIETARY
 LCRSWIXC

COVER SHEET

PLAN SHEET DISCLAIMER:

1. EVERY REASONABLE EFFORT HAS BEEN MADE TO ASSURE THE ACCURACY OF THESE PLANS AND ASSOCIATED DATA.
2. IN AN EFFORT TO INCREASE THE CLARITY AND LEGIBILITY OF THE PLANS, EXISTING UNDERGROUND UTILITIES WILL NOT BE SHOWN UNLESS THERE IS PROPOSED WORK THAT WILL REQUIRE EXCAVATION OR ANY OTHER EARTH DISTURBING ACTIVITY. IF PROPOSED WORK WILL REQUIRE THIS TYPE OF ACTIVITY, EXISTING UNDERGROUND UTILITIES WILL BE PROPERLY INVESTIGATED AND REPRESENTED ON THE PLAN SHEET OF THE RESPECTIVE WORK LOCATION

UTILITIES

1. THE IDENTITY AND LOCATION OF EXISTING UNDERGROUND UTILITIES LOCATED IN AND AROUND THE CONSTRUCTION AREA HAVE BEEN SHOWN AND LABELED ON THE PLANS BY USING INFORMATION PROVIDED BY THE RESPECTIVE UTILITY OWNERS.
2. SUPPORT AND PROTECTION OF ALL UTILITIES AND APPURTENANCES SHALL BE THE RESPONSIBILITY OF THE CONTRACTOR. COSTS FOR THE REPAIR AND RESTORATION OF EXISTING UTILITIES DAMAGED BY THE CONTRACTOR SHALL BE THE RESPONSIBILITY OF THE CONTRACTOR
3. CALL 811 BEFORE YOU DIG. AT LEAST 48 HOURS PRIOR TO EXCAVATION.

WORK LIMITS

1. THE WORK LIMITS SHOWN ON THESE PLANS ARE FOR PHYSICAL CONSTRUCTION ONLY. THE INSTALLATION AND OPERATION OF ALL TEMPORARY TRAFFIC CONTROL AND TEMPORARY TRAFFIC CONTROL DEVICES REQUIRED BY THESE PLANS SHALL BE PROVIDED BY THE CONTRACTOR WHETHER INSIDE OR OUTSIDE OF THESE WORK LIMITS.

MAINTAIN DRAINAGE

1. THE CONTRACTOR AT HIS OWN EXPENSE, SHALL MAINTAIN THE FLOW IN ALL SEWERS, DRAINS, FIELD TILES, AND WATERCOURSES ENCOUNTERED IN AND AROUND THE PROJECT SITE. IF SUCH WATERCOURSES OR DRAINS ARE DISTURBED OR DESTROYED DURING THE EXECUTION OF THE PROJECT, THEY SHALL BE RESTORED BY THE CONTRACTOR AT HIS OWN EXPENSE TO A CONDITION SATISFACTORY TO THE ENGINEER.

SECURING EXCAVATIONS & TRENCHES FOR NON-WORKING HOURS

1. EXCAVATIONS AND TRENCHES OVER 24-INCHES DEEP SHALL BE SECURELY PLATED OR BACKFILLED DURING NON-WORKING HOURS.

EXCAVATION OF ROADWAY AND RIGHT-OF-WAY AREAS

1. ANY CONTRACTOR PERFORMING EXCAVATION, INCLUDING BUT NOT LIMITED TO DISTURBING THE EARTH WITH POWERED OR NON-POWERED EQUIPMENT, DRILLING AND/OR BORING, SHALL CAUSE NOTICE TO BE GIVEN BY CALLING 811 AT LEAST 48 HOURS BUT NOT MORE THAN 10 WORKING DAYS BEFORE EXCAVATING.
2. THE EXCAVATOR SHALL PROTECT AND PRESERVE THE MARKINGS UNTIL THOSE MARKINGS ARE NO LONGER NEEDED. IF AN EXCAVATION WILL COVER A LARGE AREA AND/OR PROGRESS FROM ONE AREA TO THE NEXT OVER A PERIOD OF TIME, THE EXCAVATOR SHALL COORDINATE THE MARKING OF APPROXIMATE LOCATIONS OF CITY OWNED FACILITIES WITH THE ACTUAL EXCAVATION.
3. THE CONTRACTOR IS RESPONSIBLE FOR LOCATING ALL CUSTOMER OWNED SERVICE LINES/LATERALS. THE CONTRACTOR SHALL FIELD VERIFY THE HORIZONTAL AND VERTICAL LOCATION OF ANY CITY OR CUSTOMER OWNED MAIN OR SERVICE LINE/LATERALS THAT MAY BE AFFECTED BY THE PROPOSED CONSTRUCTION ACTIVITIES. FIELD VERIFICATION SHALL TAKE PLACE PRIOR TO ANY ACTIVITY THAT MAY JEOPARDIZE THE INTEGRITY OF THE FACILITY AND AT A LOCATION NEAREST THE POINT OF POSSIBLE CONFLICT.
4. ANY DAMAGES TO CITY OR CUSTOMER OWNED FACILITIES SHOULD FIRST BE REPORTED TO THE UTILITY OWNER THEN IMMEDIATELY NOTIFY THE PROJECT ENGINEER.















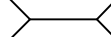































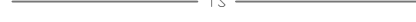

AERIAL CONSTRUCTION:

1. CONTRACTOR TO VERIFY ALL BONDING AND GROUNDING COMPLES WITH NESC GUIDELINES.
2. CONSTRUCTION TO VERIFY ALL REQUIRED MAKE READY WORK IS COMPLETE BEFORE PLACING ON UTILITY POLES.

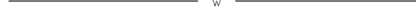



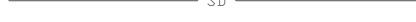
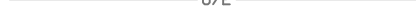



SAFETY NOTE:

1. CHECK IN WITH CONSTRUCTION SUPERVISOR WHEN ARRIVING ON-SITE.
2. HEAVY CONSTRUCTION EQUIPMENT IN USE. BEWARE OF SURROUNDINGS.
3. FOLLOW CONGRUEX SAFETY POLICIES AND GUIDELINES AT ALL TIMES WHILE WORKING.
4. CONSTRUCTION ZONE/ HARD HAT, SAFETY GLASSES, REFLECTIVE VEST/SHIRT, SAFETY TOE BOOTS REQUIRED – WORK SAFELY

EXISTING EQUIPMENTS LEGENDS

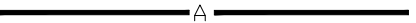
	R/W		CABINET		ELECTRIC TRANSFORMER		GAS METER		CULVERT
	CENTER LINE		EXISTING PED		ELECTRIC METER		GAS VALVE		C/L MONUMENT
	EOP		EXISTING FLOWERPOT		ELECTRIC VAULT/HANDHOLE		SEWER MANHOLE		ANCHOR & DOWN GUY
	BOC		EXISTING HANDHOLE		ELECTRIC MANHOLE		UNKNOWN MANHOLE		
	PROPERTY LINE		TELEPHONE CABINET		EXISTING VAULT		WATER METER		
	FENCE		TELEPHONE MANHOLE		STREETLIGHT		WATER VALVE		
	TELCO		POLE		POWER PED		FIRE HYDRANT		
	ELECTRIC		CABLE MARKER		CATV PED		WATER MANHOLE		
	GAS		STREET SIGN		CATV VAULT/HANDHOLE		STORM DRAIN CATCH BASIN		
	TRAFFIC SIGNAL		VERTICAL GROUND		TREE		STORM DRAIN MANHOLE		
	WATER		ELECTRIC PEDESTAL/CABINET		TRANSFORMER				
	SEWER								
	STORM DRAIN								
	UTILITY EASEMENT								
	RAIL TRACKS								
	SIDEWALK								

PROPOSED EQUIPMENTS LEGENDS

	BORE		12"X24"X18" HANDHOLE
	TRENCH		17"X30"X18" HANDHOLE
	AERIAL FIBER		24"X36"X24" HANDHOLE
	AERIAL STRAND		36"X48"X30" HANDHOLE
			ANCHOR & DOWN GUY

MINIMUM STANDARDS FOR DIRECTIONAL BORING
STREET CROSSINGS

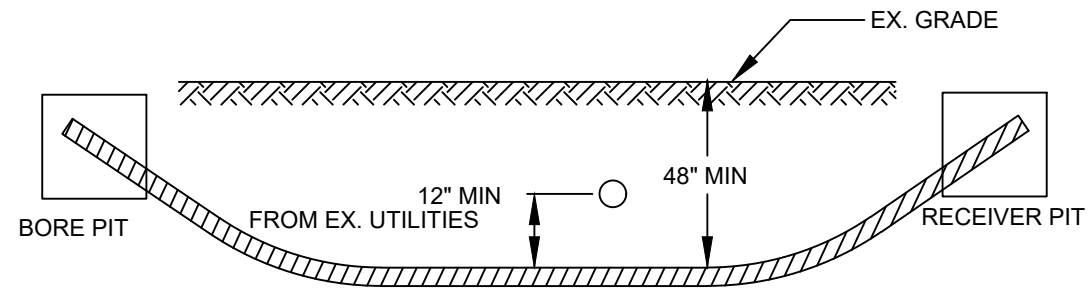

- PLACE END MARKER WITH UTILITY OWNER'S NAME DESCRIBING CONDUIT
- BORE PIT TO BE BACKFILLED AND COMPACTED IN 12" LIFTS WITH MATERIAL REMOVED
- FLOW OF DITCH MUST BE MAINTAINED AT ALL TIMES
- PROTECT ROOTS AT ALL TREE LOCATIONS, SHIFT BORE TRENCH IF NECESSARY

TYPICAL BORE DETAILS 1

MINIMUM STANDARDS FOR DIRECTIONAL BORING
UNDER SIDEWALKS & WITHIN ROW (EXCLUDING STREET CROSSINGS)

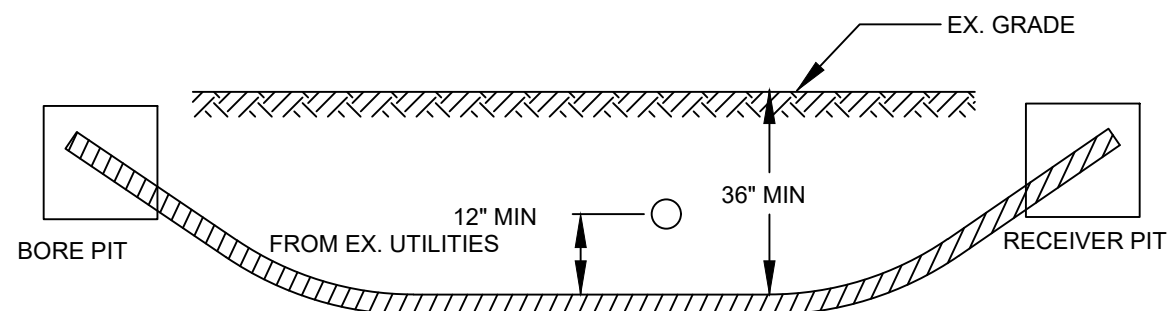

- PLACE END MARKER WITH UTILITY OWNER'S NAME DESCRIBING CONDUIT
- BORE PIT TO BE BACKFILLED AND COMPACTED IN 12" LIFTS WITH MATERIAL REMOVED
- FLOW OF DITCH MUST BE MAINTAINED AT ALL TIMES
- PROTECT ROOTS AT ALL TREE LOCATIONS, SHIFT BORE TRENCH IF NECESSARY

TYPICAL BORE DETAILS 2

PLAN VIEW

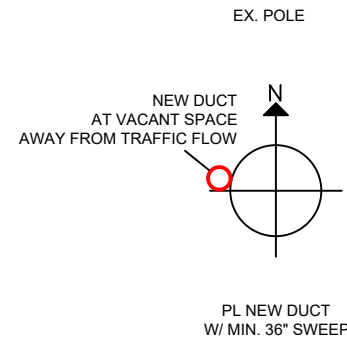

ELEVATION

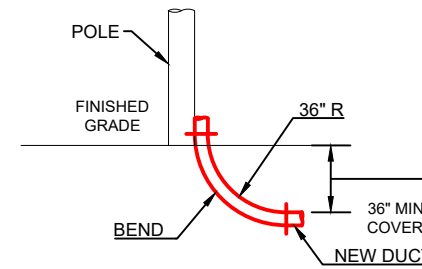

RISER DETAILS

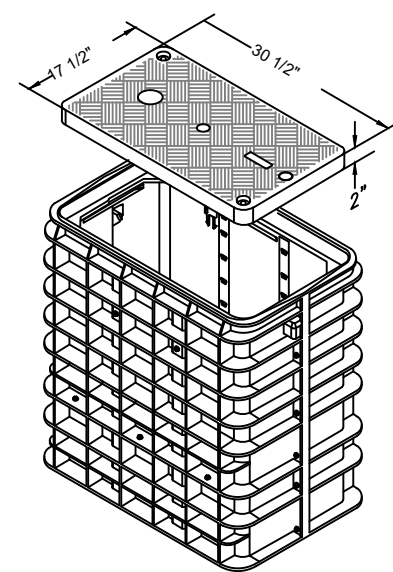

17"x30"x18"
N.T.S.

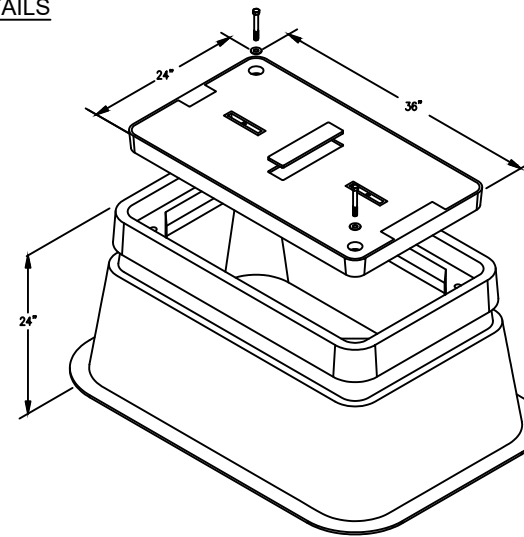

24"x36"x24"
N.T.S.

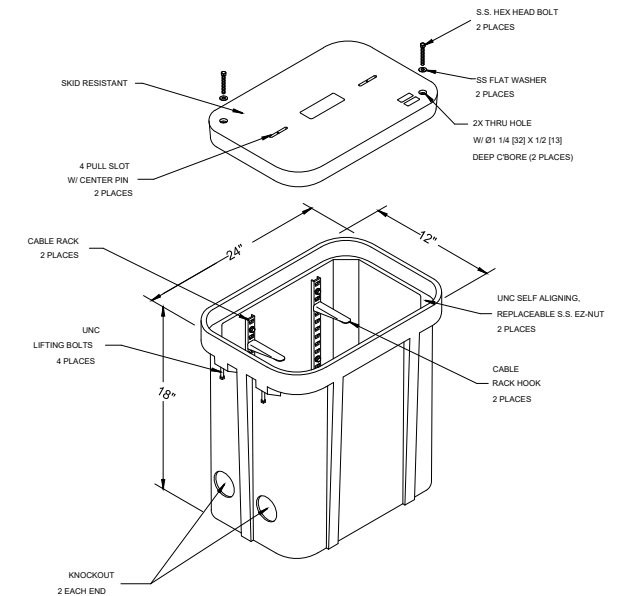

12"x24"x18"
N.T.S.

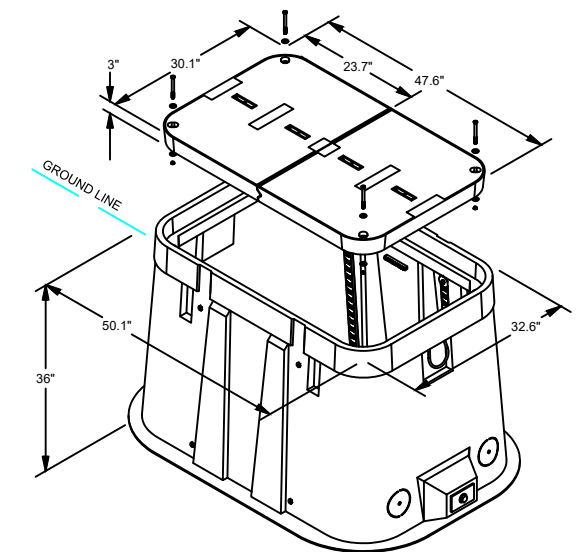

30"x48"x36"
N.T.S.

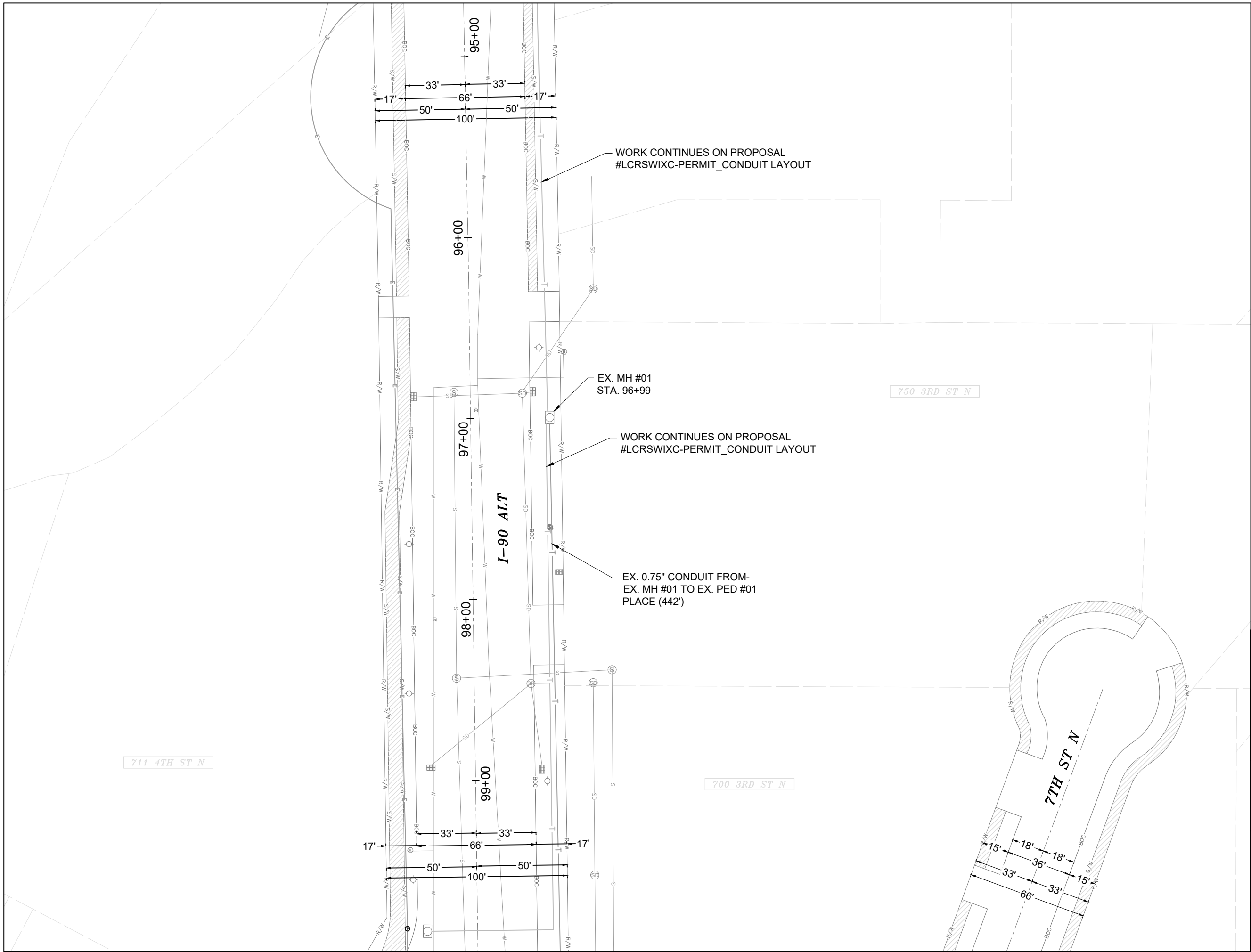
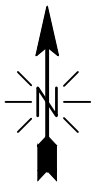

750 3RD ST N

711 4TH ST N

700 3RD ST N

7TH ST N

MATCH TO SHEET 06

CALL 811 BEFORE YOU DIG.
WISCONSIN TOLL FREE
800-242-8511



CONFIDENTIAL AND PROPRIETARY
LCRSWIXC

05 OF 32

SCALE: 1" = 50'

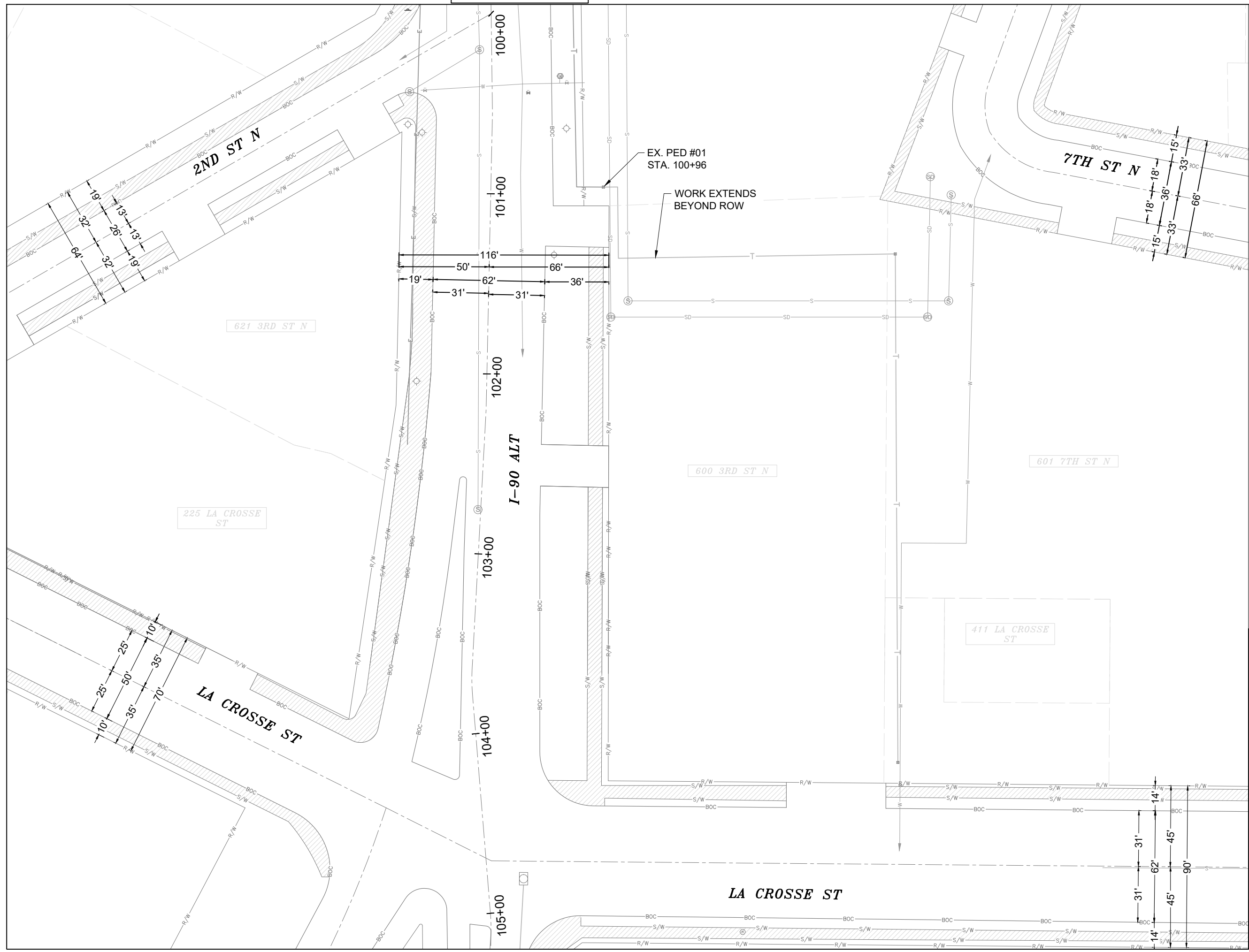

CALL 811 BEFORE YOU DIG.
 WISCONSIN TOLL FREE
 800-242-8511



CONFIDENTIAL AND PROPRIETARY
 LCRSWIXC

06 OF 32
 SCALE: 1" = 50'

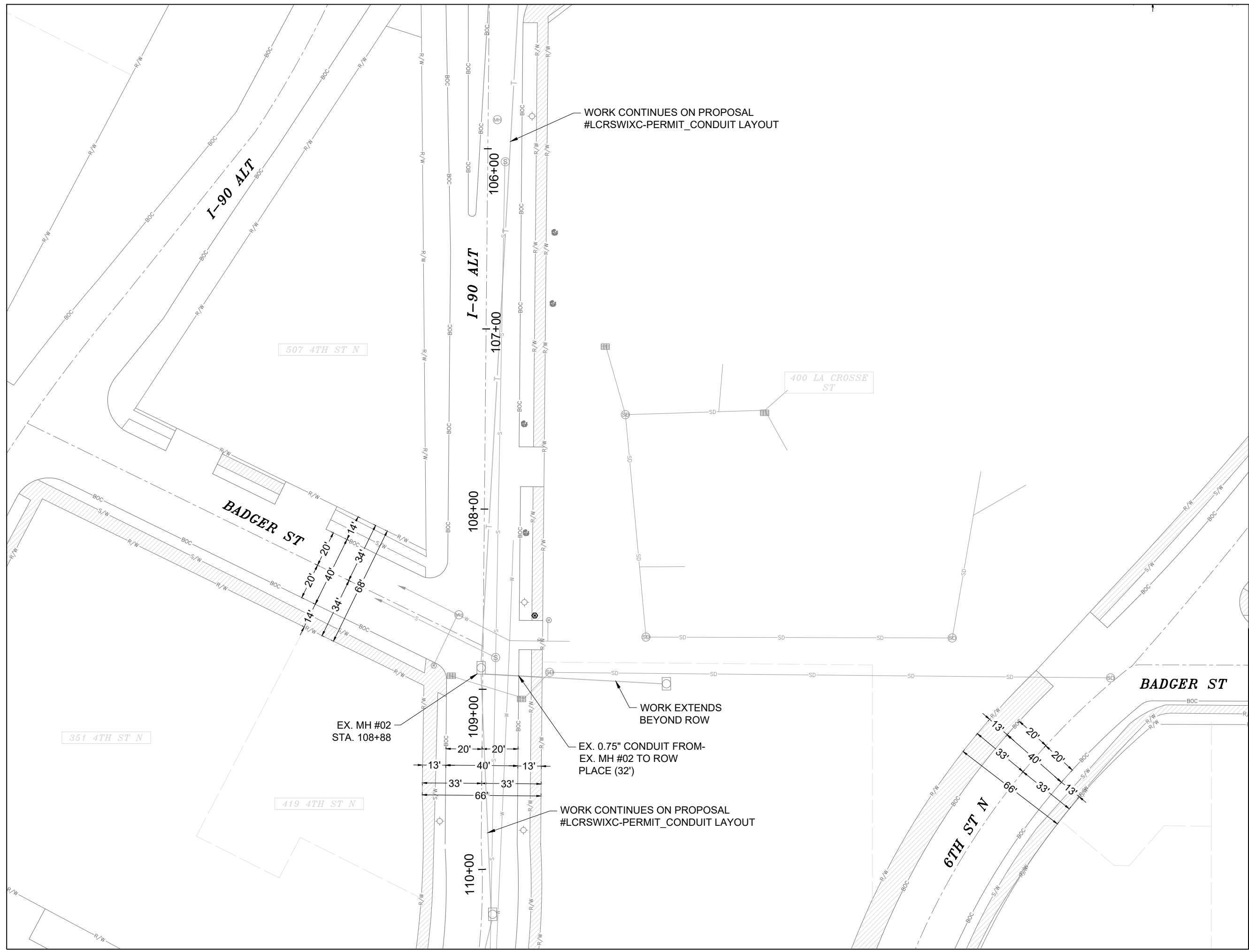
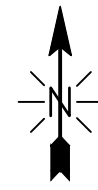

WORK CONTINUES ON PROPOSAL
#LCRSWIXC-PERMIT_CONDUIT LAYOUT

400 LA CROSSE
ST

507 4TH ST N

BADGER ST

BADGER ST

351 4TH ST N

EX. MH #02
STA. 108+88

419 4TH ST N

6TH ST N

WORK EXTENDS
BEYOND ROW

EX. 0.75" CONDUIT FROM-
EX. MH #02 TO ROW
PLACE (32')

WORK CONTINUES ON PROPOSAL
#LCRSWIXC-PERMIT_CONDUIT LAYOUT

CALL 811 BEFORE YOU DIG.
WISCONSIN TOLL FREE
800-242-8511



CONFIDENTIAL AND PROPRIETARY
LCRSWIXC

07 OF 32

SCALE: 1" = 50'

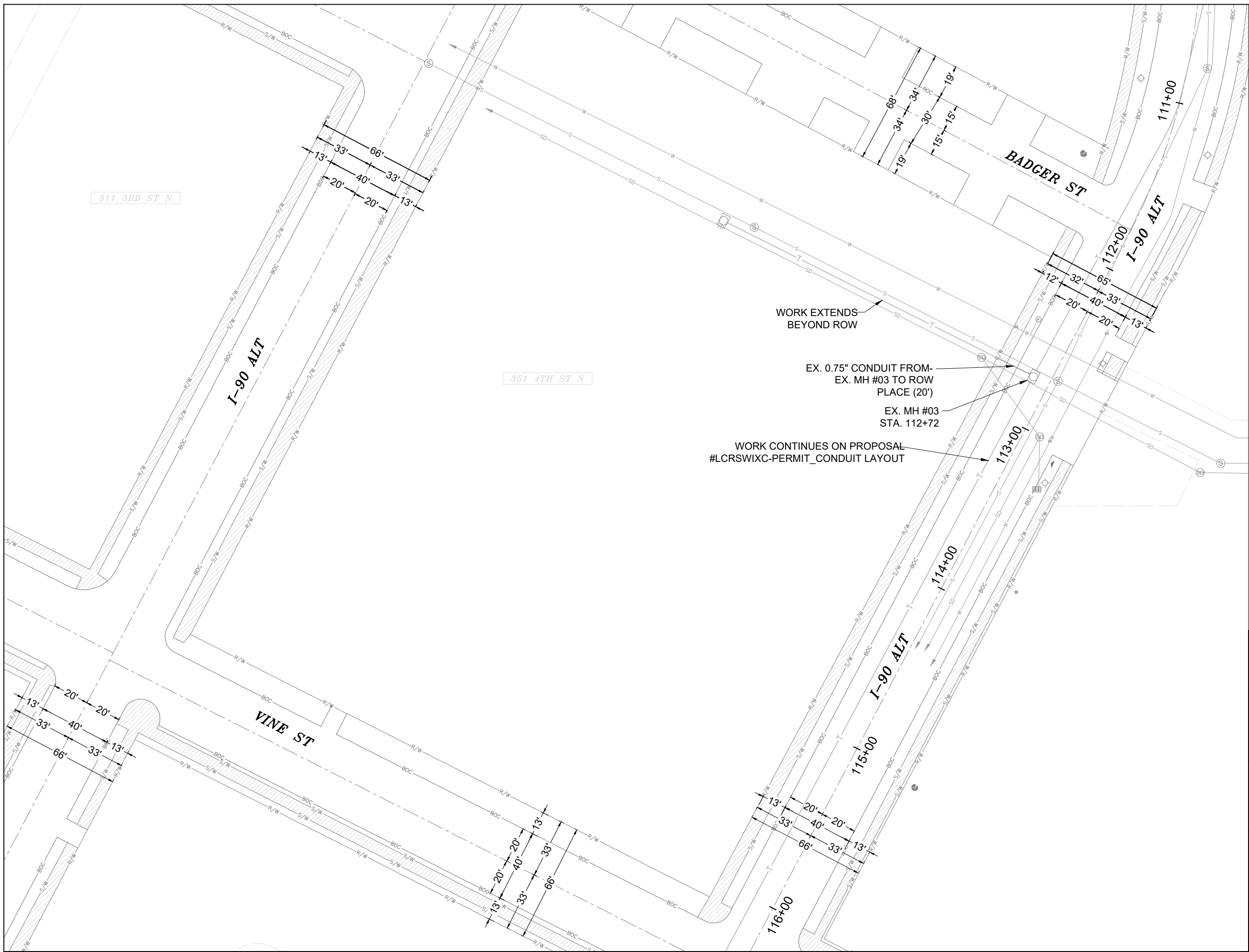
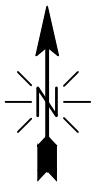

CALL 811 BEFORE YOU DIG.
 WISCONSIN TOLL FREE
 800-242-8511



CONFIDENTIAL AND PROPRIETARY
 LCRSWIXC

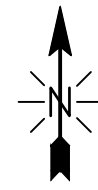

MATCH TO SHEET 10

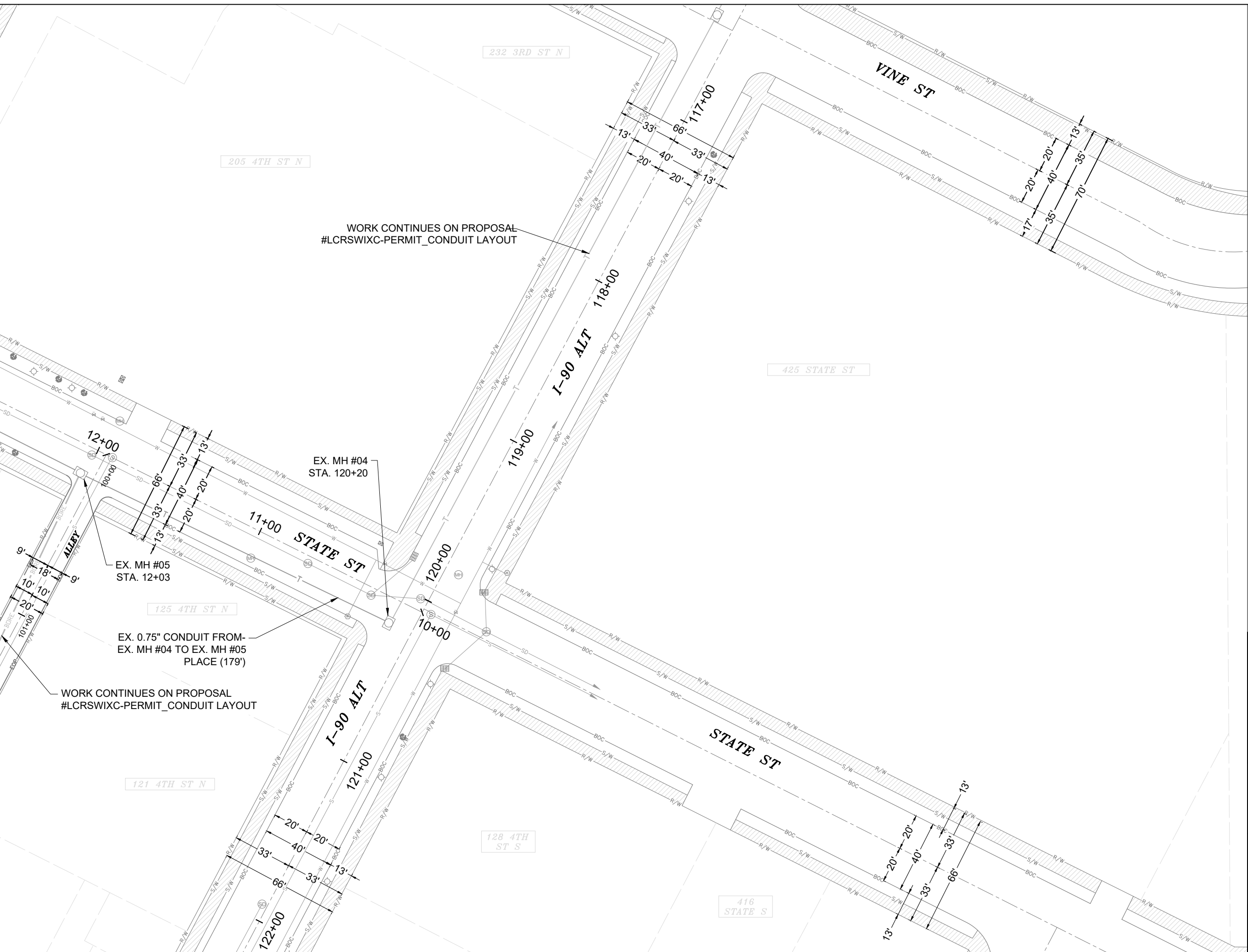

WORK CONTINUES ON PROPOSAL #LCRSWIXC-PERMIT_CONDUIT LAYOUT

EX. MH #04 STA. 120+20

EX. MH #05 STA. 12+03

EX. 0.75" CONDUIT FROM- EX. MH #04 TO EX. MH #05 PLACE (179')

WORK CONTINUES ON PROPOSAL #LCRSWIXC-PERMIT_CONDUIT LAYOUT

CALL 811 BEFORE YOU DIG.
WISCONSIN TOLL FREE
800-242-8511



CONFIDENTIAL AND PROPRIETARY
LCRSWIXC

09 OF 32

SCALE: 1" = 50'

MATCH TO SHEET 11

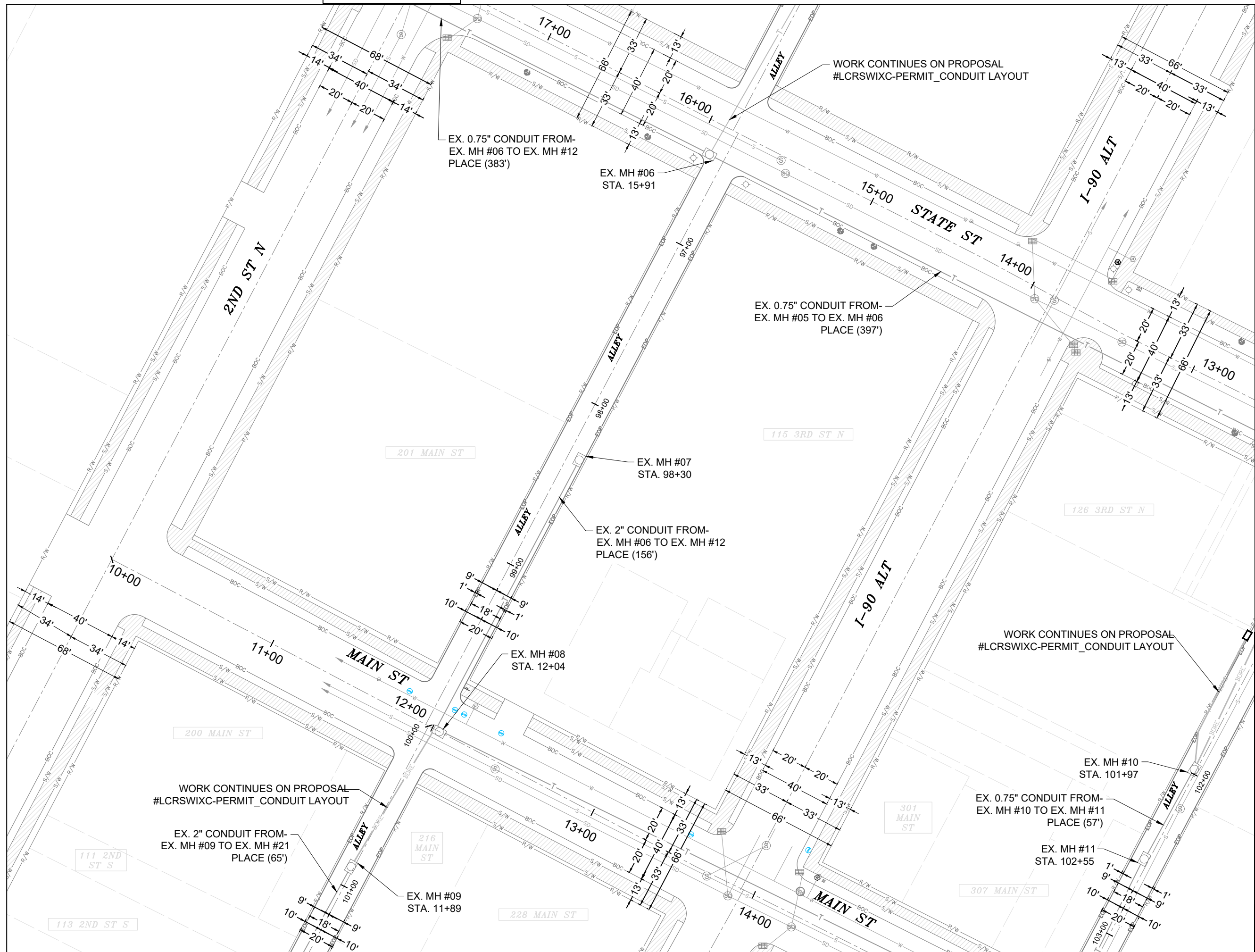

MATCH TO SHEET 09

CALL 811 BEFORE YOU DIG.
 WISCONSIN TOLL FREE
 800-242-8511



CONFIDENTIAL AND PROPRIETARY
 LCRSWIXC

10 OF 32

SCALE: 1" = 50'

MATCH TO SHEET 16

MATCH TO SHEET 16

WORK CONTINUES ON PROPOSAL
 #LCRSWIXC-PERMIT_CONDUIT_LAYOUT

EX. 2" CONDUIT FROM-
 EX. MH #09 TO EX. MH #21
 PLACE (65')

EX. MH #09
 STA. 11+89

EX. 0.75" CONDUIT FROM-
 EX. MH #06 TO EX. MH #12
 PLACE (383')

EX. MH #06
 STA. 15+91

EX. 2" CONDUIT FROM-
 EX. MH #06 TO EX. MH #12
 PLACE (156')

EX. MH #07
 STA. 98+30

EX. MH #08
 STA. 12+04

EX. 0.75" CONDUIT FROM-
 EX. MH #10 TO EX. MH #11
 PLACE (57')

EX. MH #10
 STA. 101+97

EX. MH #11
 STA. 102+55

WORK CONTINUES ON PROPOSAL
 #LCRSWIXC-PERMIT_CONDUIT_LAYOUT

WORK CONTINUES ON PROPOSAL
 #LCRSWIXC-PERMIT_CONDUIT_LAYOUT

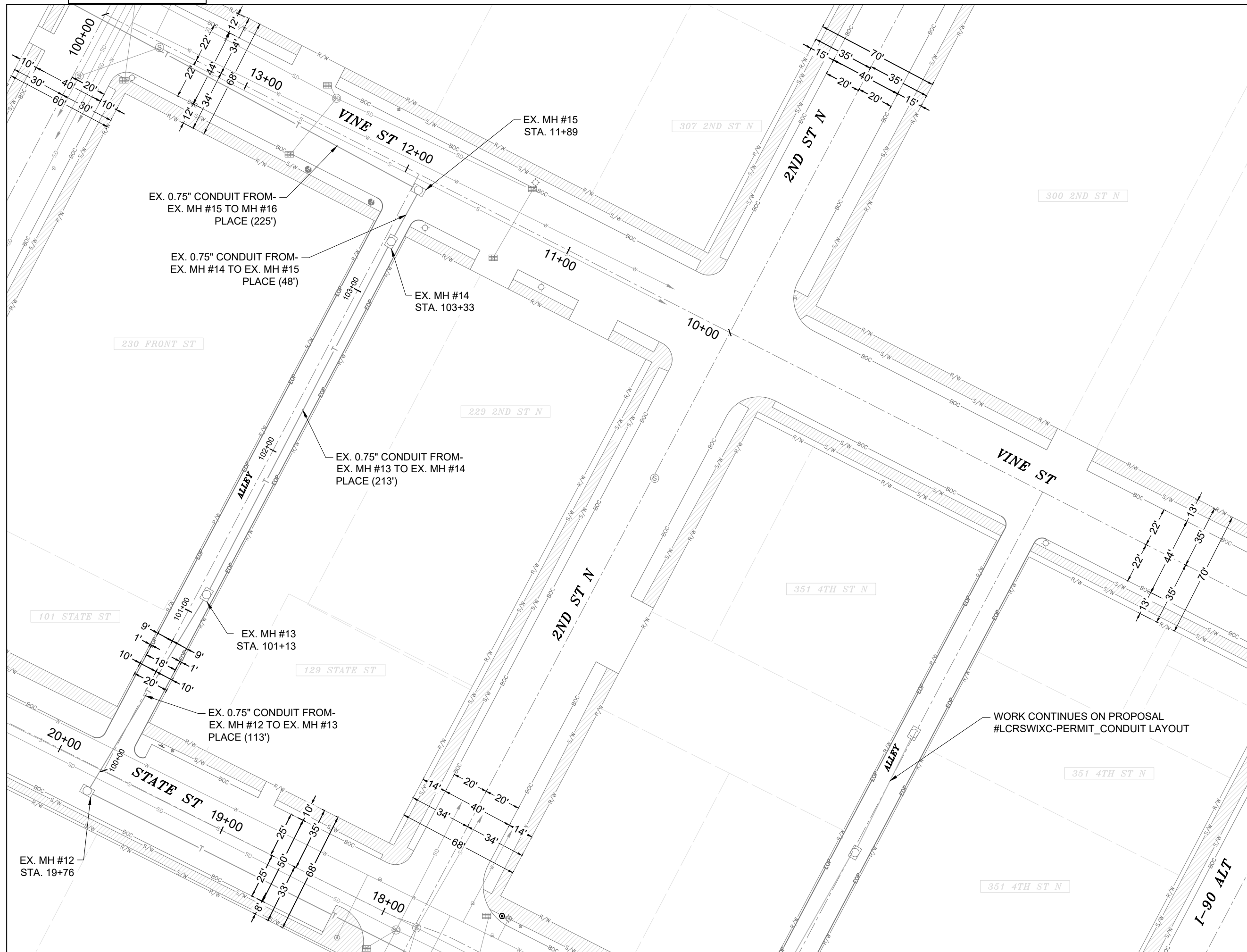
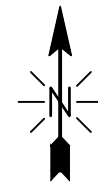

CALL 811 BEFORE YOU DIG.
 WISCONSIN TOLL FREE
 800-242-8511



CONFIDENTIAL AND PROPRIETARY
 LCRSWIXC

MATCH TO SHEET 13

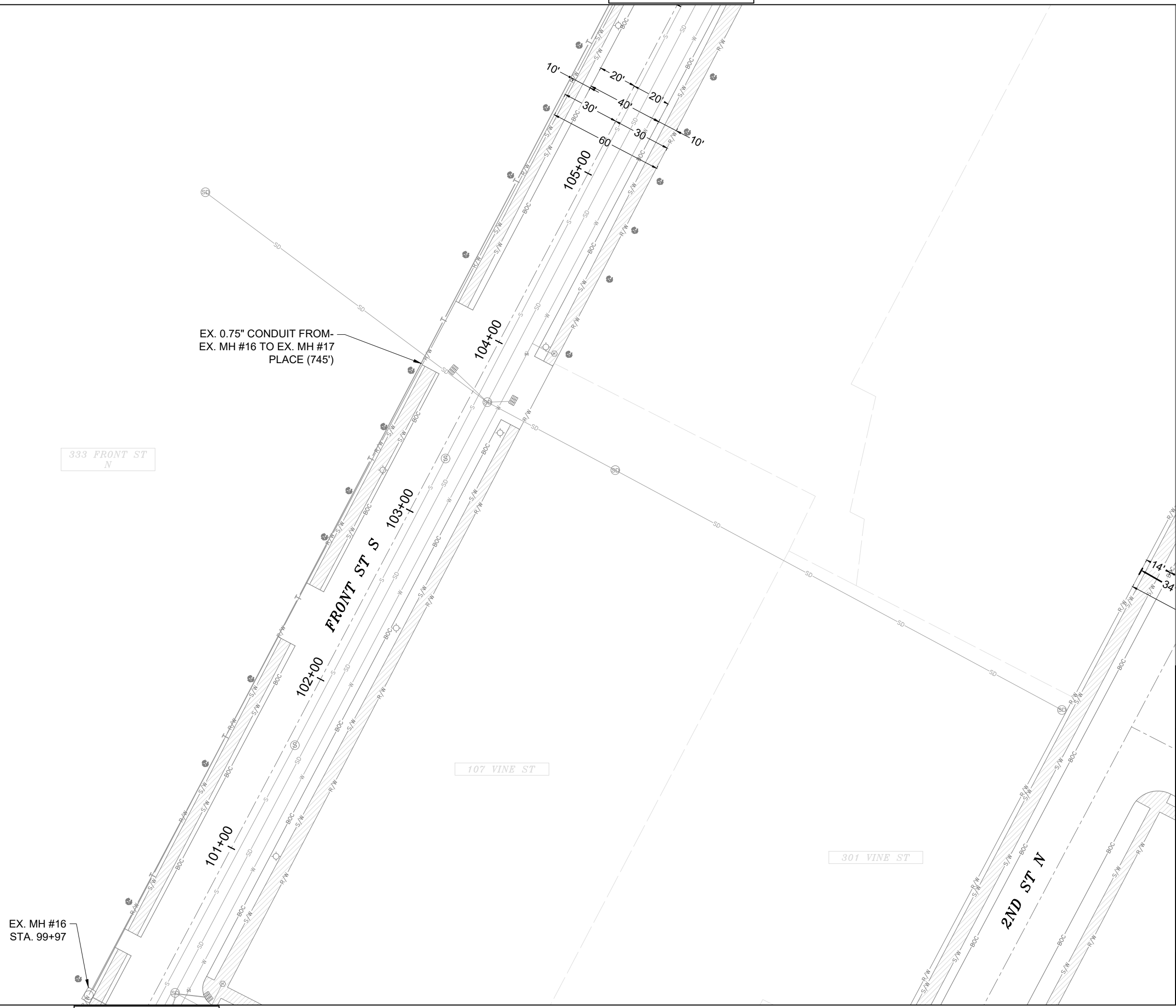
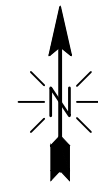

EX. 0.75" CONDUIT FROM-
EX. MH #16 TO EX. MH #17
PLACE (745')

333 FRONT ST
N

107 VINE ST

301 VINE ST

2ND ST N

EX. MH #16
STA. 99+97

MATCH TO SHEET 11

CALL 811 BEFORE YOU DIG.
WISCONSIN TOLL FREE
800-242-8511



CONFIDENTIAL AND PROPRIETARY
LCRSWIXC

12 OF 32

SCALE: 1" = 50'

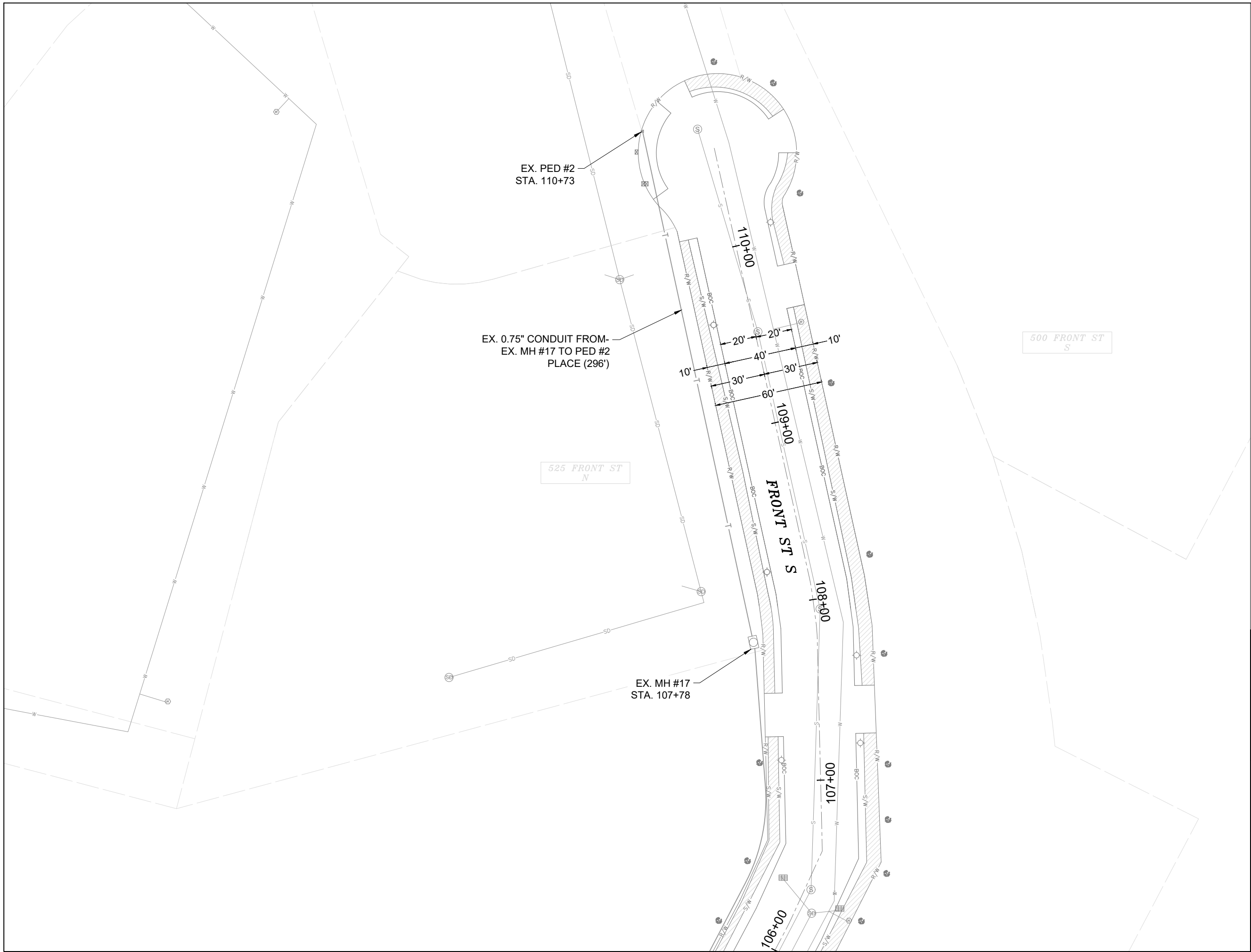
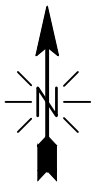

500 FRONT ST S

525 FRONT ST N

FRONT ST S

CALL 811 BEFORE YOU DIG.
WISCONSIN TOLL FREE
800-242-8511



CONFIDENTIAL AND PROPRIETARY
LCRSWIXC

13 OF 32

SCALE: 1" = 50'

MATCH TO SHEET 12

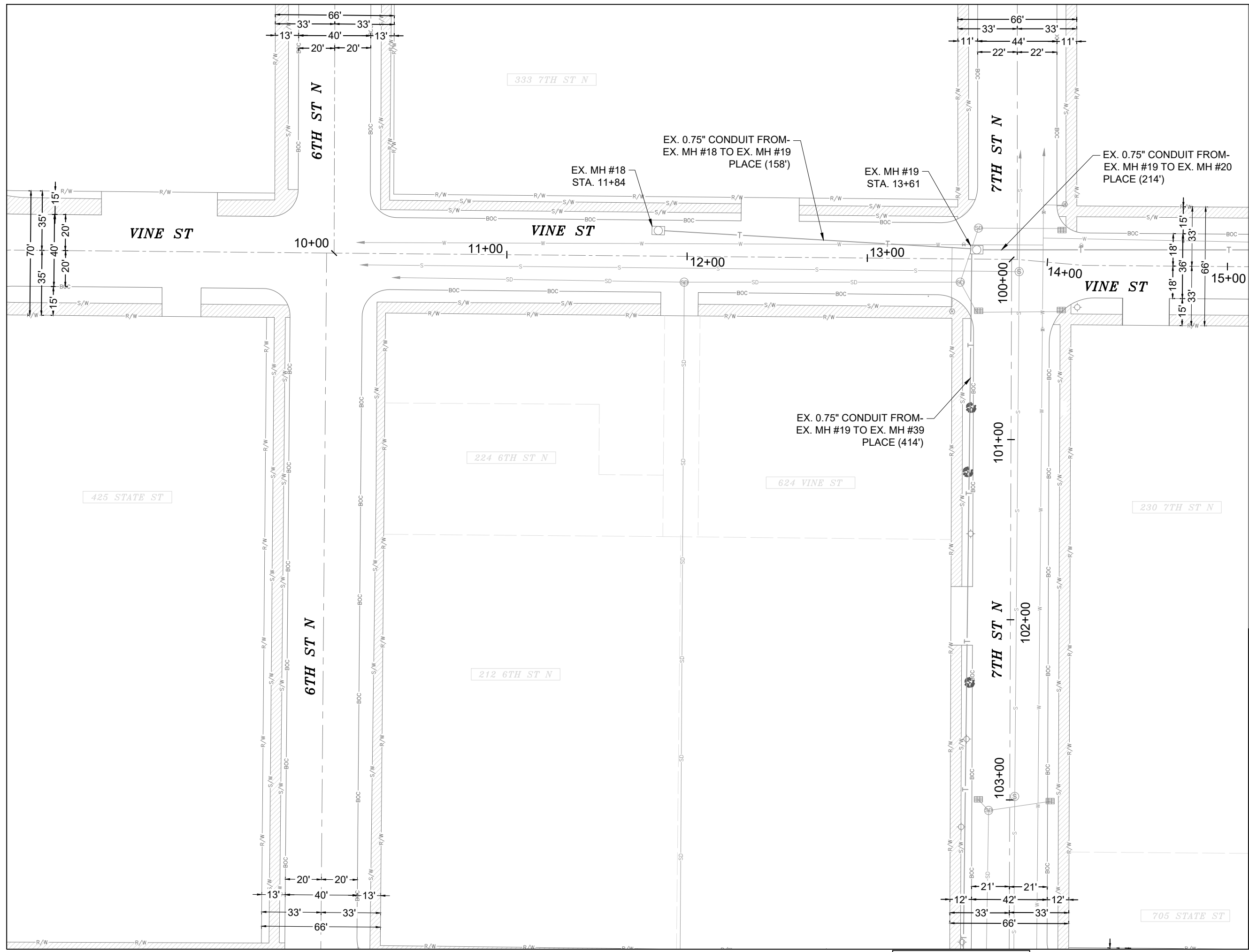
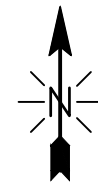

MATCH TO SHEET 15

MATCH TO SHEET 18

CALL 811 BEFORE YOU DIG.
WISCONSIN TOLL FREE
800-242-8511



CONFIDENTIAL AND PROPRIETARY
LCRSWIXC

14 OF 32
SCALE: 1" = 50'

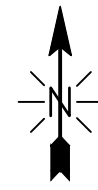

MATCH TO SHEET 14

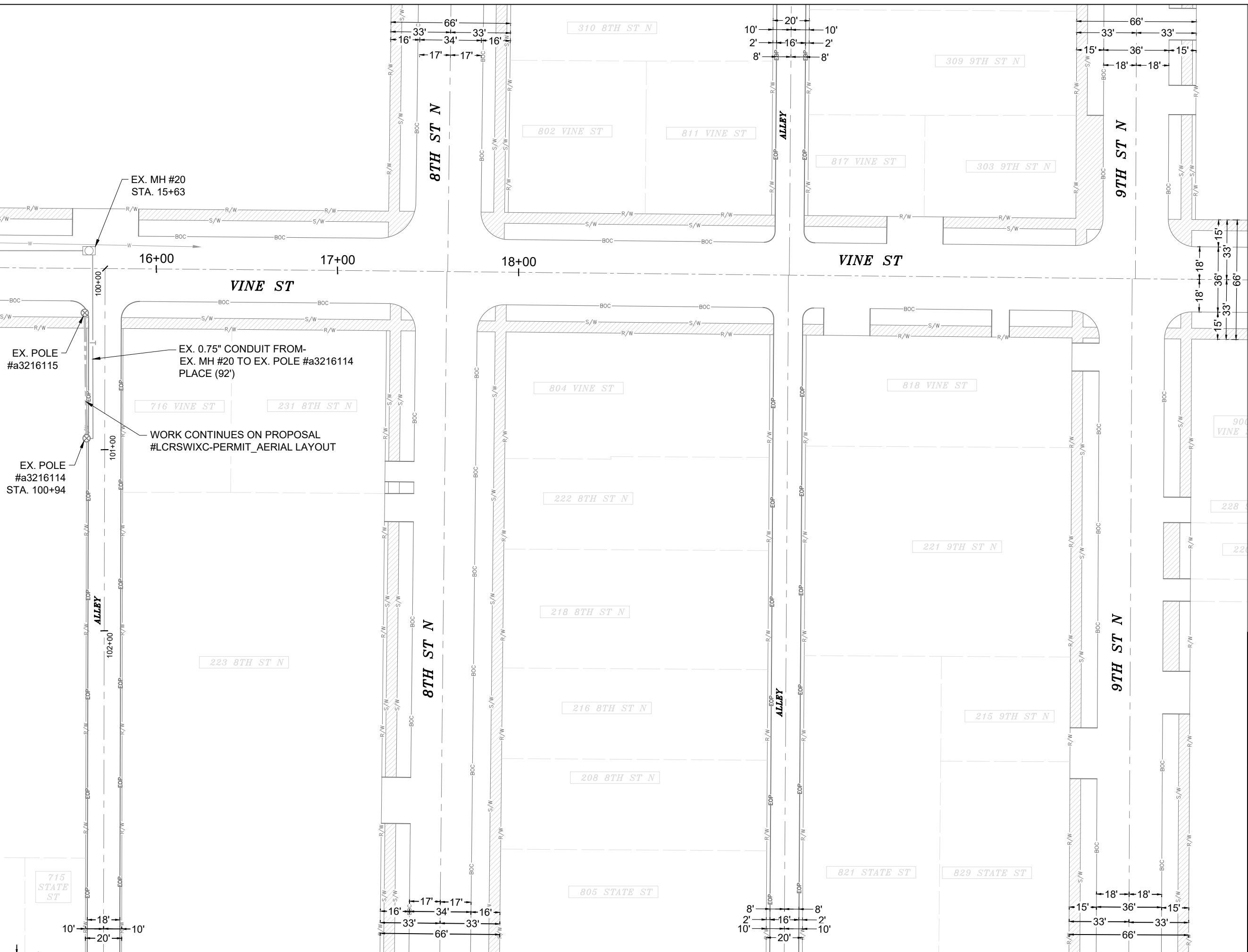

EX. MH #20
STA. 15+63

EX. POLE
#a3216115

EX. POLE
#a3216114
STA. 100+94

EX. 0.75" CONDUIT FROM-
EX. MH #20 TO EX. POLE #a3216114
PLACE (92')

WORK CONTINUES ON PROPOSAL
#LCRSWIXC-PERMIT_AERIAL LAYOUT

CALL 811 BEFORE YOU DIG.
WISCONSIN TOLL FREE
800-242-8511



CONFIDENTIAL AND PROPRIETARY
LCRSWIXC

15 OF 32

SCALE: 1" = 50'

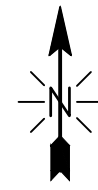
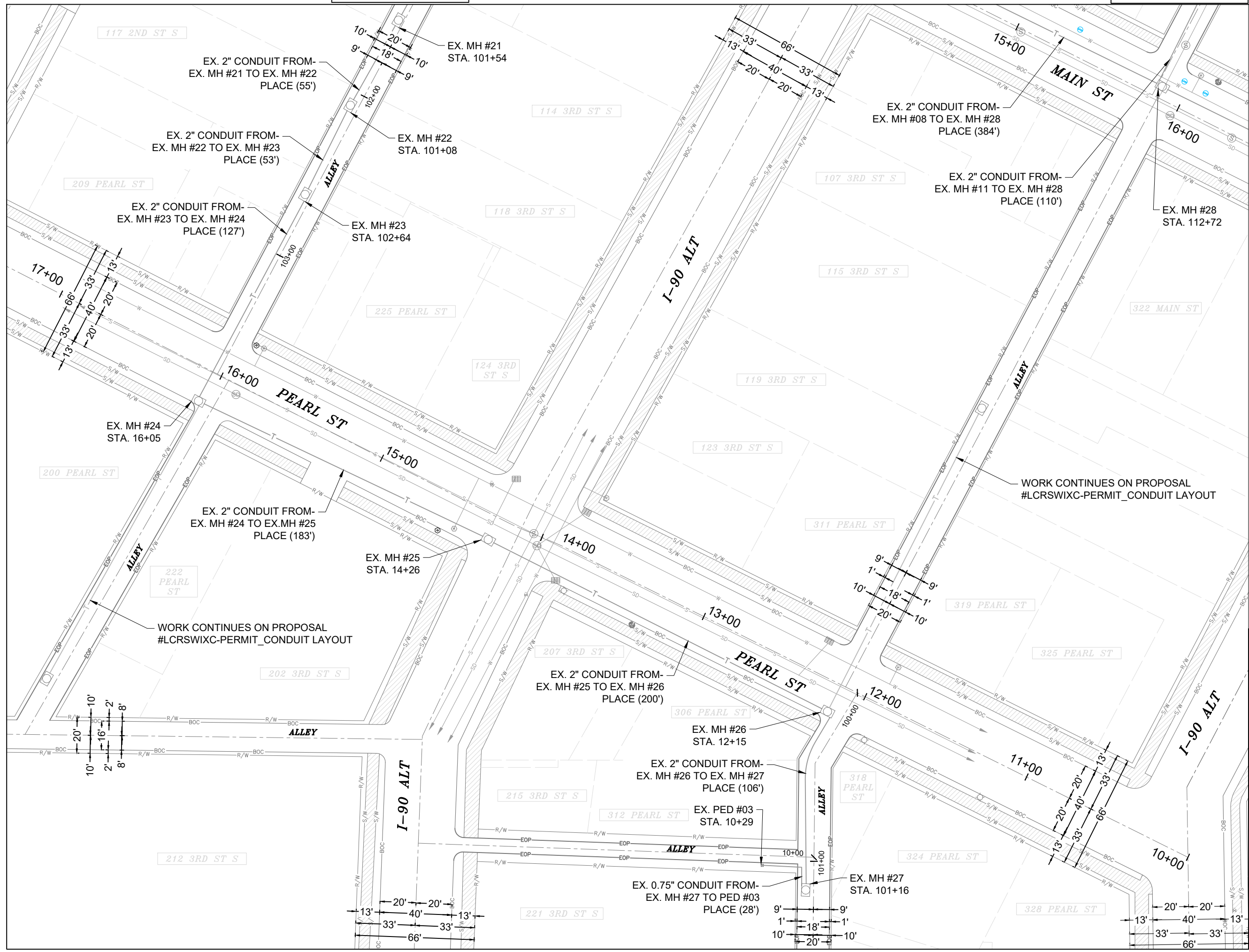

CALL 811 BEFORE YOU DIG.
 WISCONSIN TOLL FREE
 800-242-8511



CONFIDENTIAL AND PROPRIETARY
 LCRSWIXC

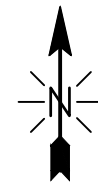

MATCH TO SHEET 16

MATCH TO SHEET 18

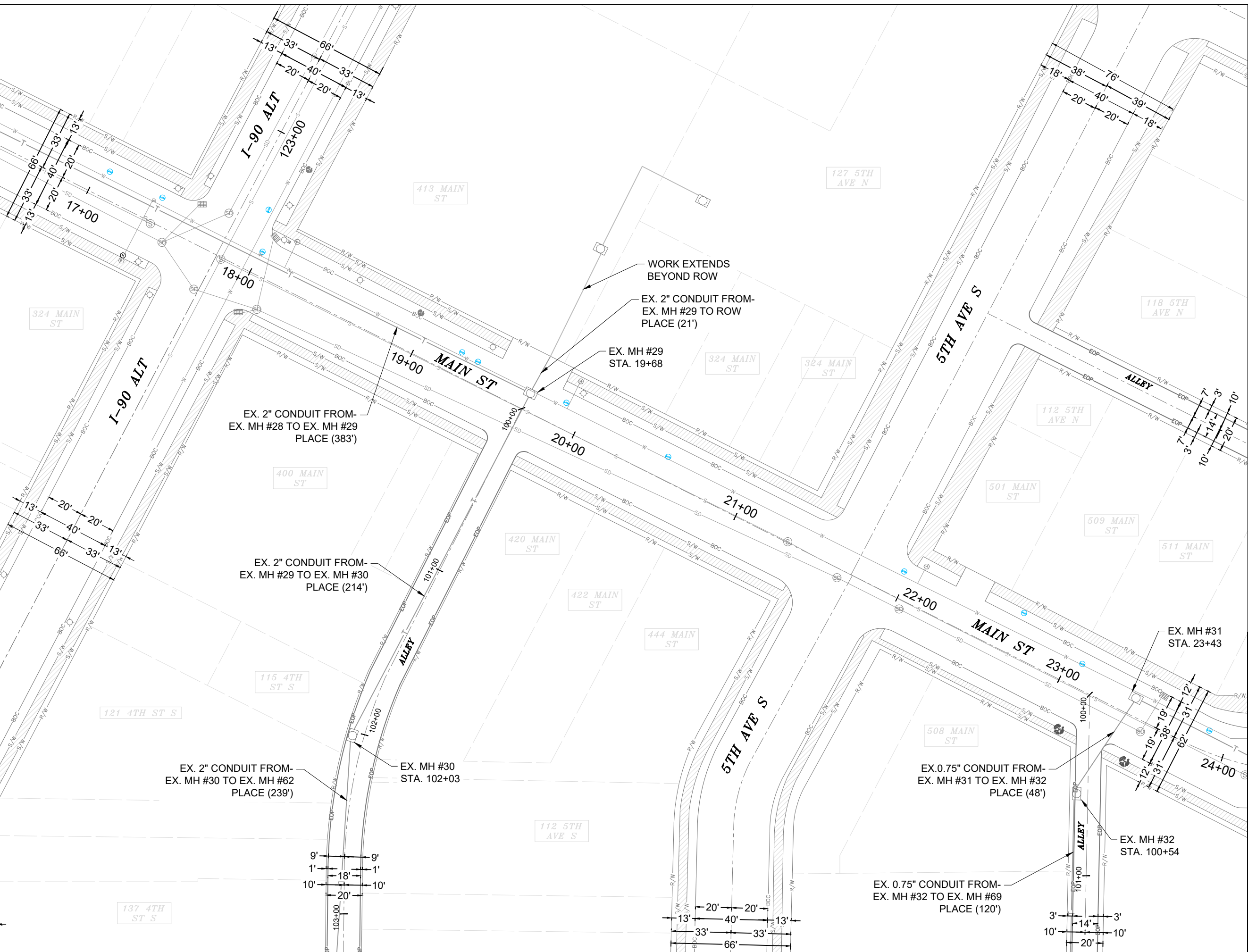

MATCH TO SHEET 23

MATCH TO SHEET 24

CALL 811 BEFORE YOU DIG.
 WISCONSIN TOLL FREE
 800-242-8511



CONFIDENTIAL AND PROPRIETARY
 LCRSWIXC

17 OF 32

SCALE: 1" = 50'

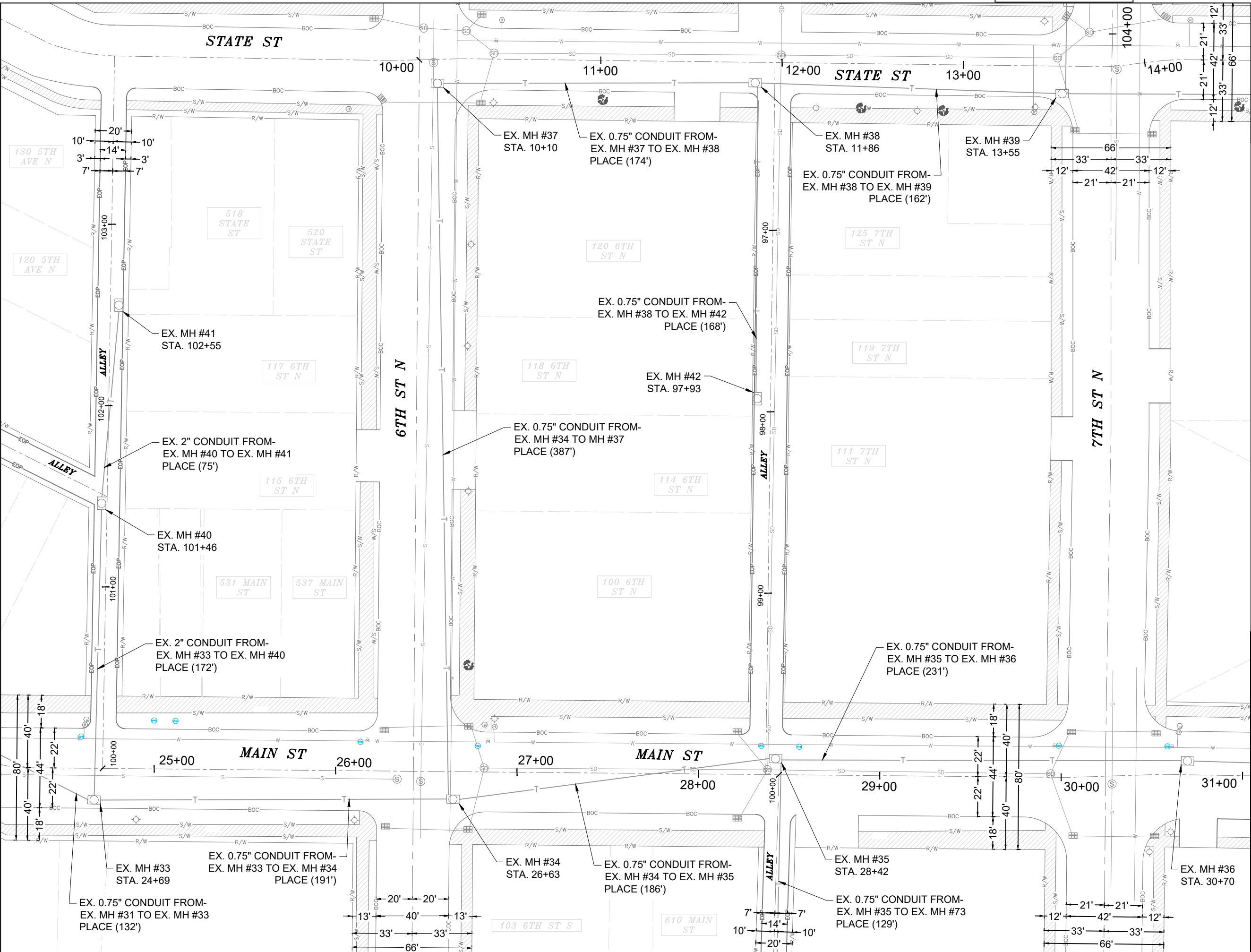
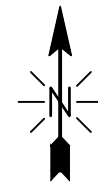

MATCH TO SHEET 19

MATCH TO SHEET 19

brightspeed

CHC
A CONGRUEX COMPANY

CONFIDENTIAL AND PROPRIETARY
LCRSWIXC

18 OF 32
SCALE: 1" = 50'

CALL 811 BEFORE YOU DIG.
WISCONSIN TOLL FREE
800-242-8511

MATCH TO SHEET 17

MATCH TO SHEET 24

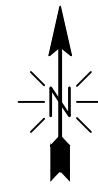

MATCH TO SHEET 18

MATCH TO SHEET 18

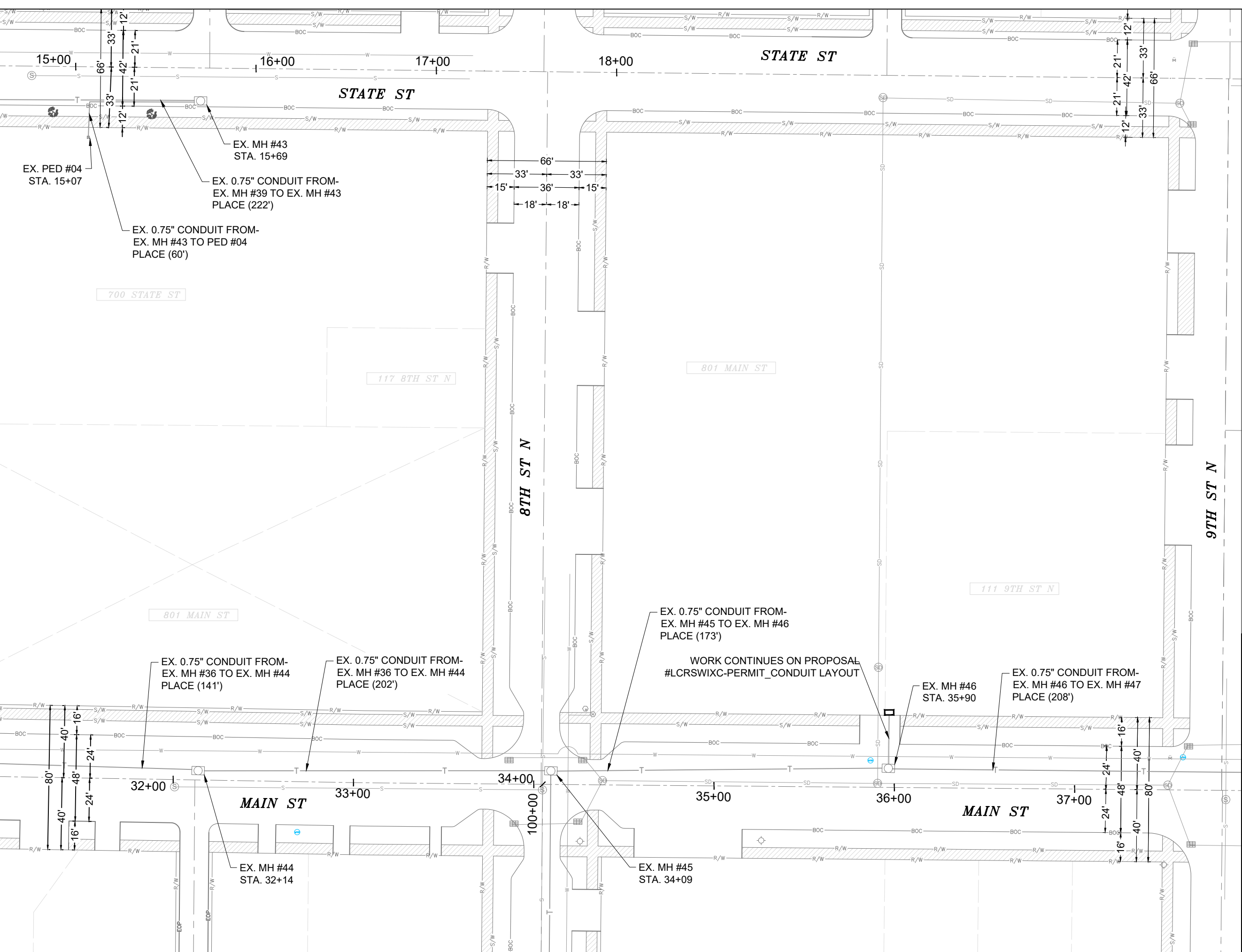

MATCH TO SHEET 20

CALL 811 BEFORE YOU DIG.
 WISCONSIN TOLL FREE
 800-242-8511



CONFIDENTIAL AND PROPRIETARY
 LCRSWIXC

19 OF 32

SCALE: 1" = 50'

MATCH TO SHEET 25

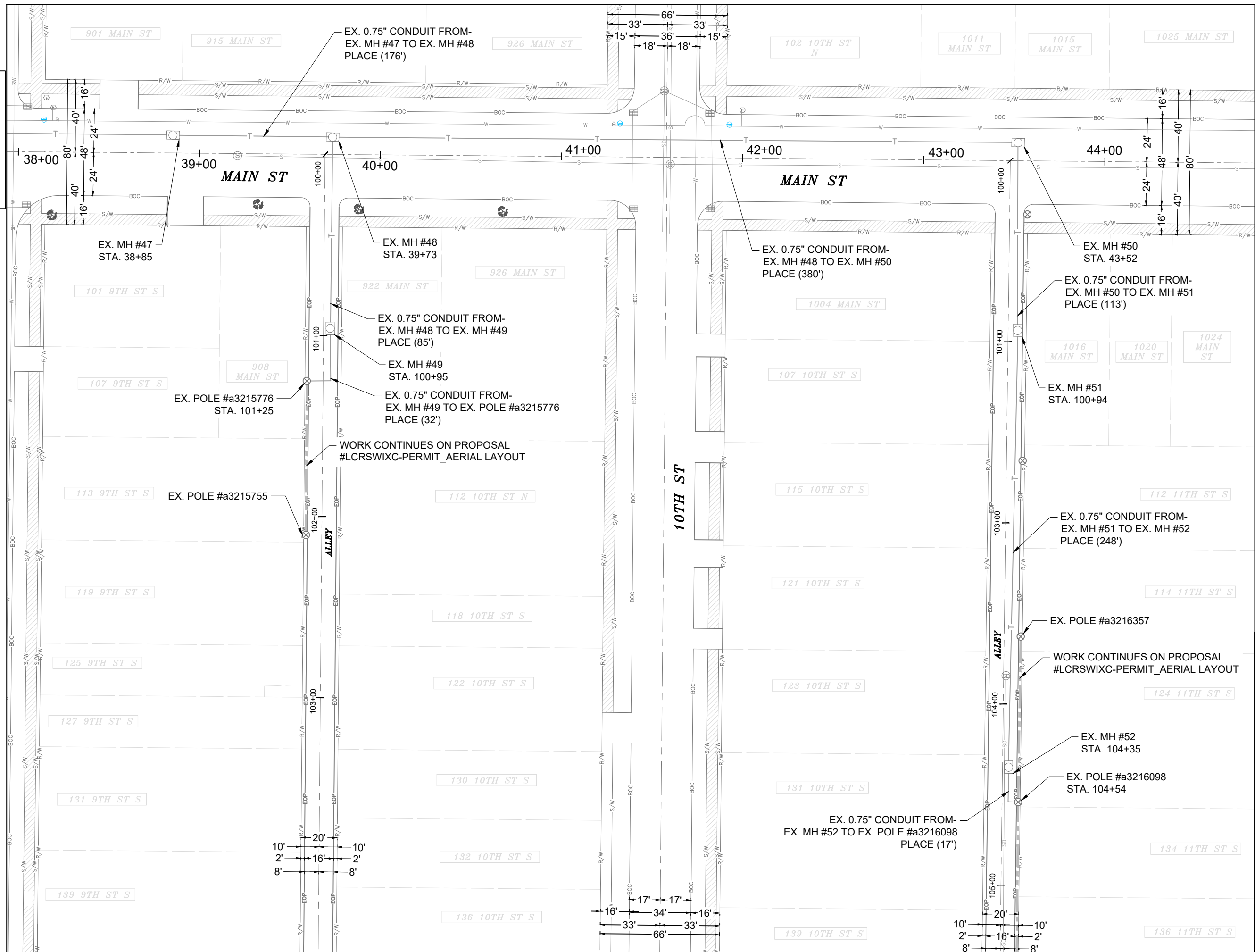

CALL 811 BEFORE YOU DIG.
 WISCONSIN TOLL FREE
 800-242-8511



CONFIDENTIAL AND PROPRIETARY
 LCRSWIXC

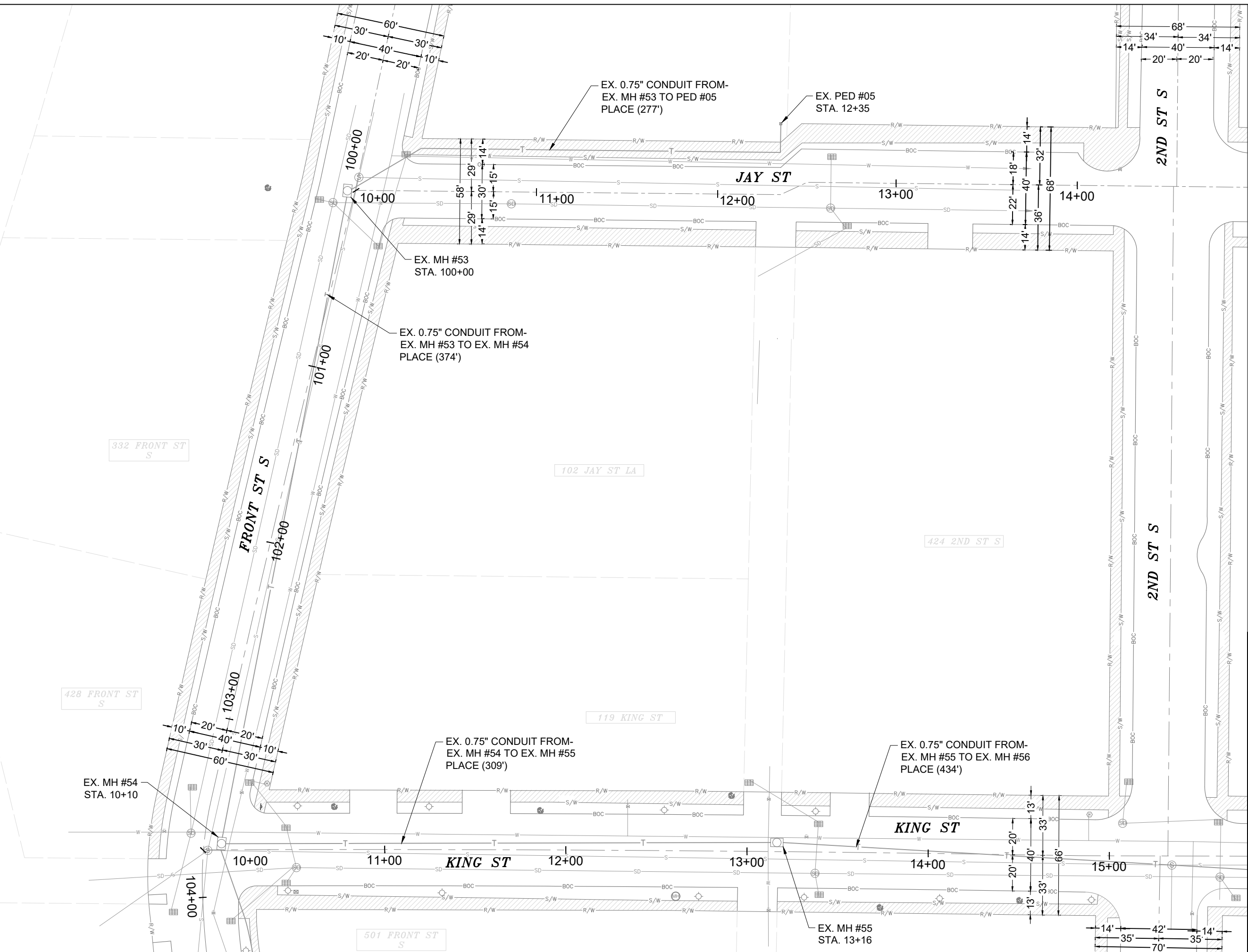
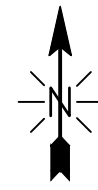

MATCH TO SHEET 22

CALL 811 BEFORE YOU DIG.
 WISCONSIN TOLL FREE
 800-242-8511



CONFIDENTIAL AND PROPRIETARY
LCRSWIXC

21 OF 32
 SCALE: 1" = 50'

MATCH TO SHEET 26

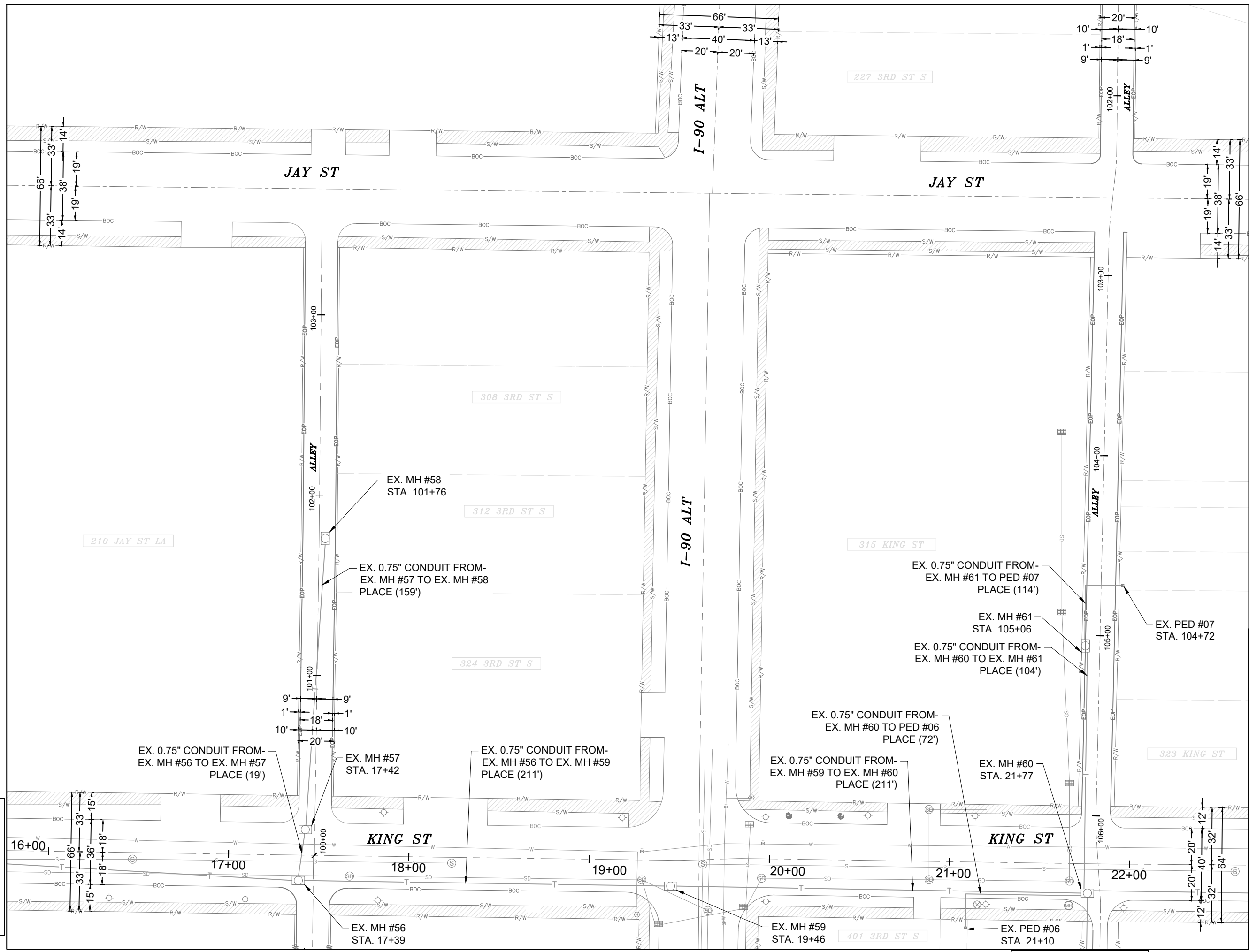
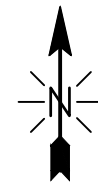

MATCH TO SHEET 21

MATCH TO SHEET 23

MATCH TO SHEET 28

CALL 811 BEFORE YOU DIG.
 WISCONSIN TOLL FREE
 800-242-8511



CONFIDENTIAL AND PROPRIETARY
 LCRSWIXC

22 OF 32

SCALE: 1" = 50'

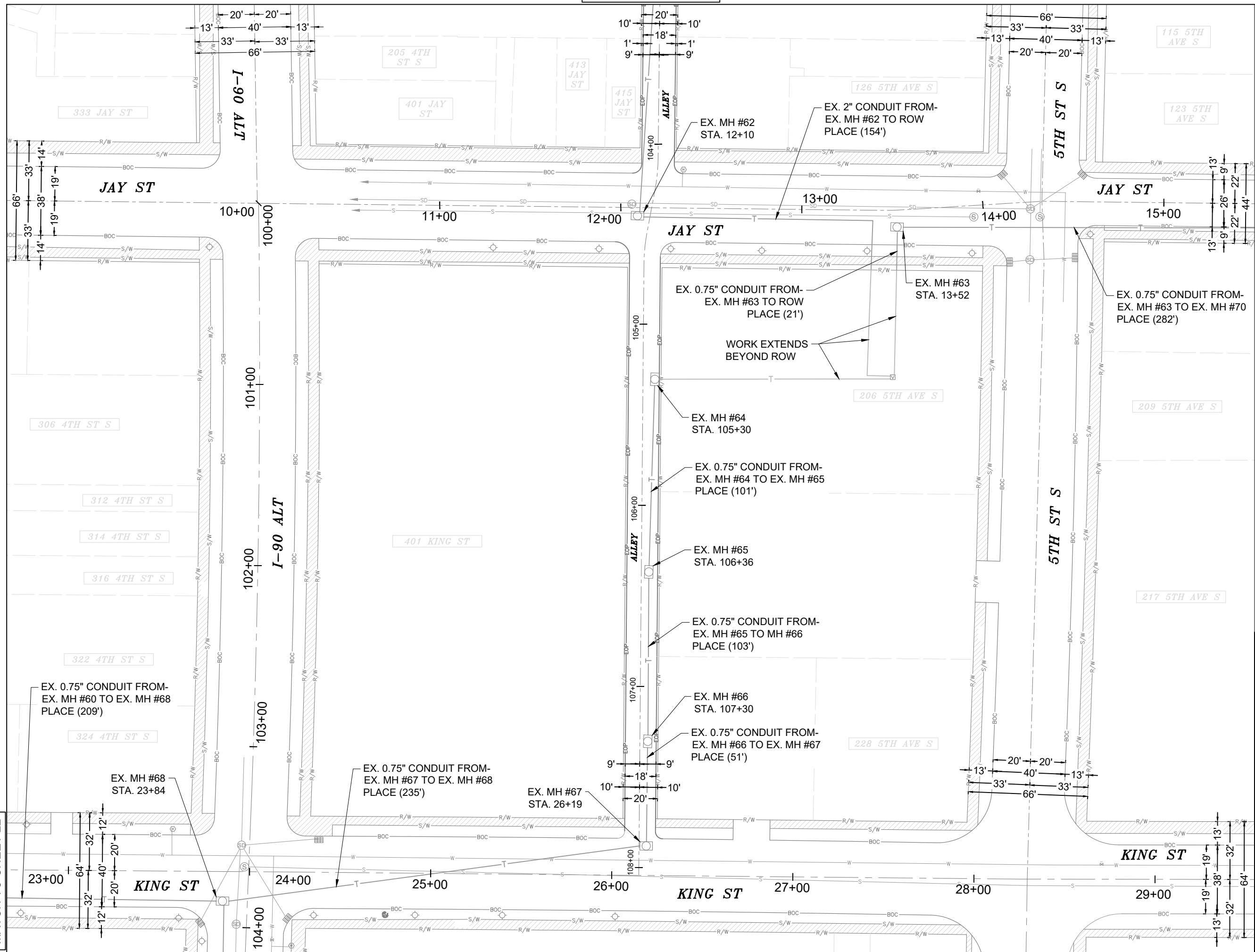
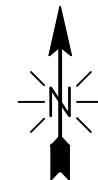

MATCH TO SHEET 24

CALL 811 BEFORE YOU DIG.
WISCONSIN TOLL FREE
800-242-8511



CONFIDENTIAL AND PROPRIETARY
LCRSWIXC

JTV 06-1

I-90 ALT

WORK EXTENDS BEYOND ROW

EX. 2" CONDUIT FROM-
EX. MH #62 TO ROW
PLACE (154')

EX. 0.75" CONDUIT FROM-
EX. MH #63 TO ROW
PLACE (21')

EX. MH #63
STA. 13+52

EX. 0.75" CONDUIT FROM-
EX. MH #63 TO EX. MH #70
PLACE (282')

EX. MH #64
STA. 105+30

EX. 0.75" CONDUIT FROM-
EX. MH #64 TO EX. MH #65
PLACE (101')

EX. MH #65
STA. 106+36

EX. 0.75" CONDUIT FROM-
EX. MH #65 TO EX. MH #66
PLACE (103')

EX. MH #66
STA. 107+30

EX. 0.75" CONDUIT FROM-
EX. MH #66 TO EX. MH #67
PLACE (51')

EX. MH #67
STA. 26+19

EX. 0.75" CONDUIT FROM-
EX. MH #67 TO EX. MH #68
PLACE (235')

EX. MH #68
STA. 23+84

EX. 0.75" CONDUIT FROM-
EX. MH #60 TO EX. MH #68
PLACE (209')

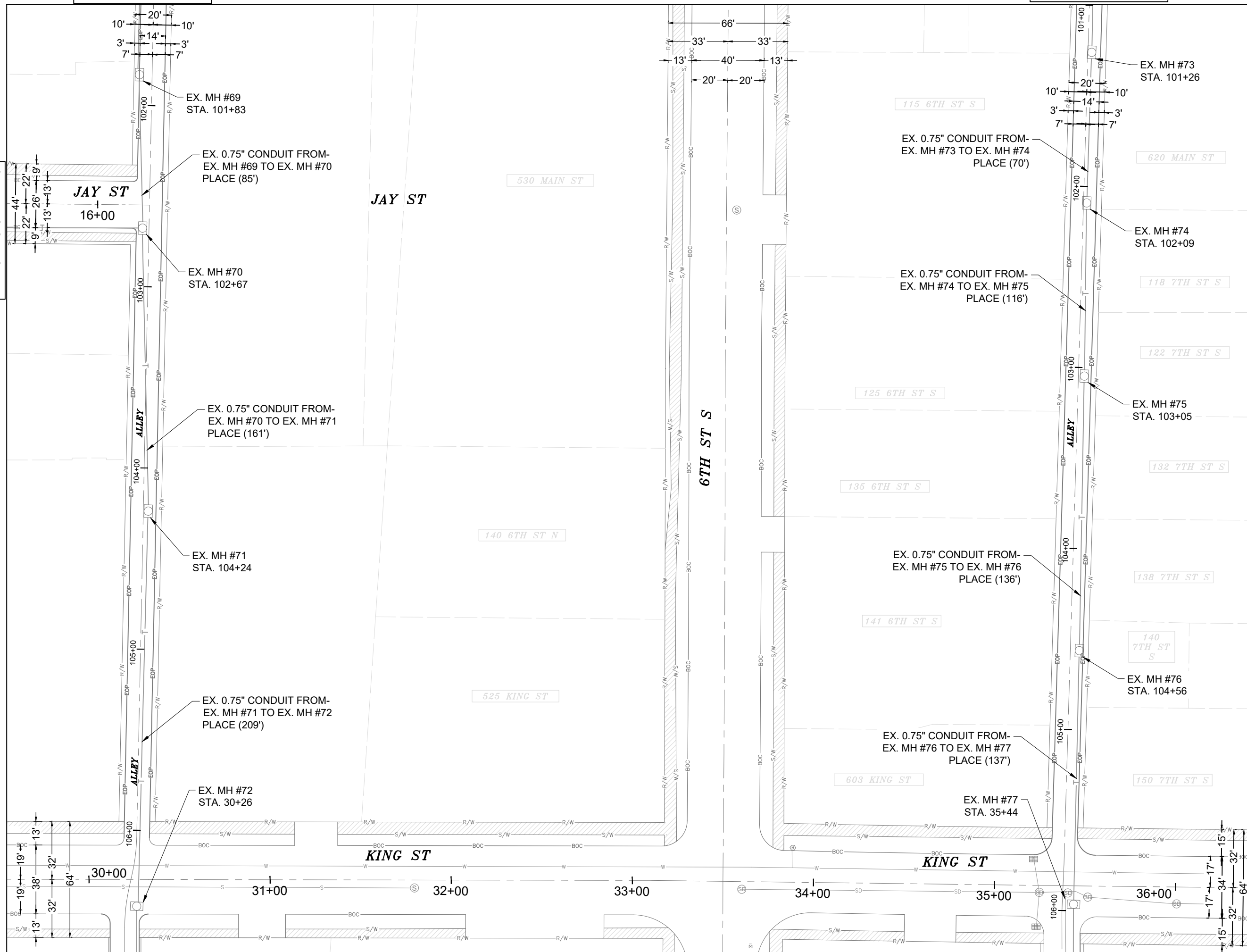
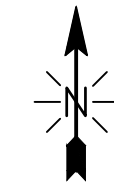

CALL 811 BEFORE YOU DIG.
 WISCONSIN TOLL FREE
 800-242-8511

CONFIDENTIAL AND PROPRIETARY
 LCRSWIXC

24 OF 32
 SCALE: 1" = 50'

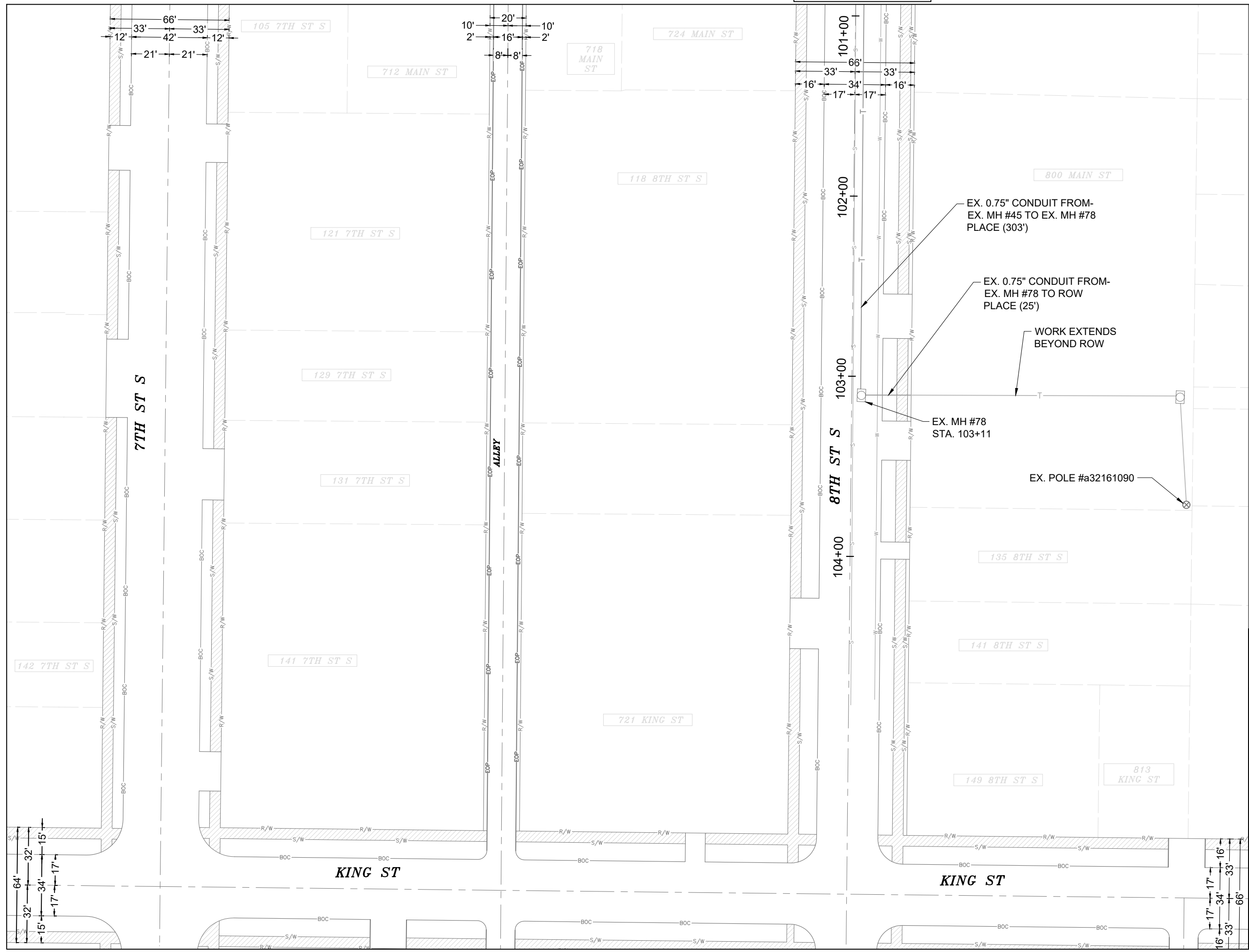

CALL 811 BEFORE YOU DIG.
 WISCONSIN TOLL FREE
 800-242-8511



CONFIDENTIAL AND PROPRIETARY
 LCRSWIXC

25 OF 32
 SCALE: 1" = 50'

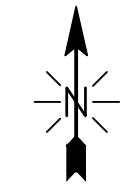
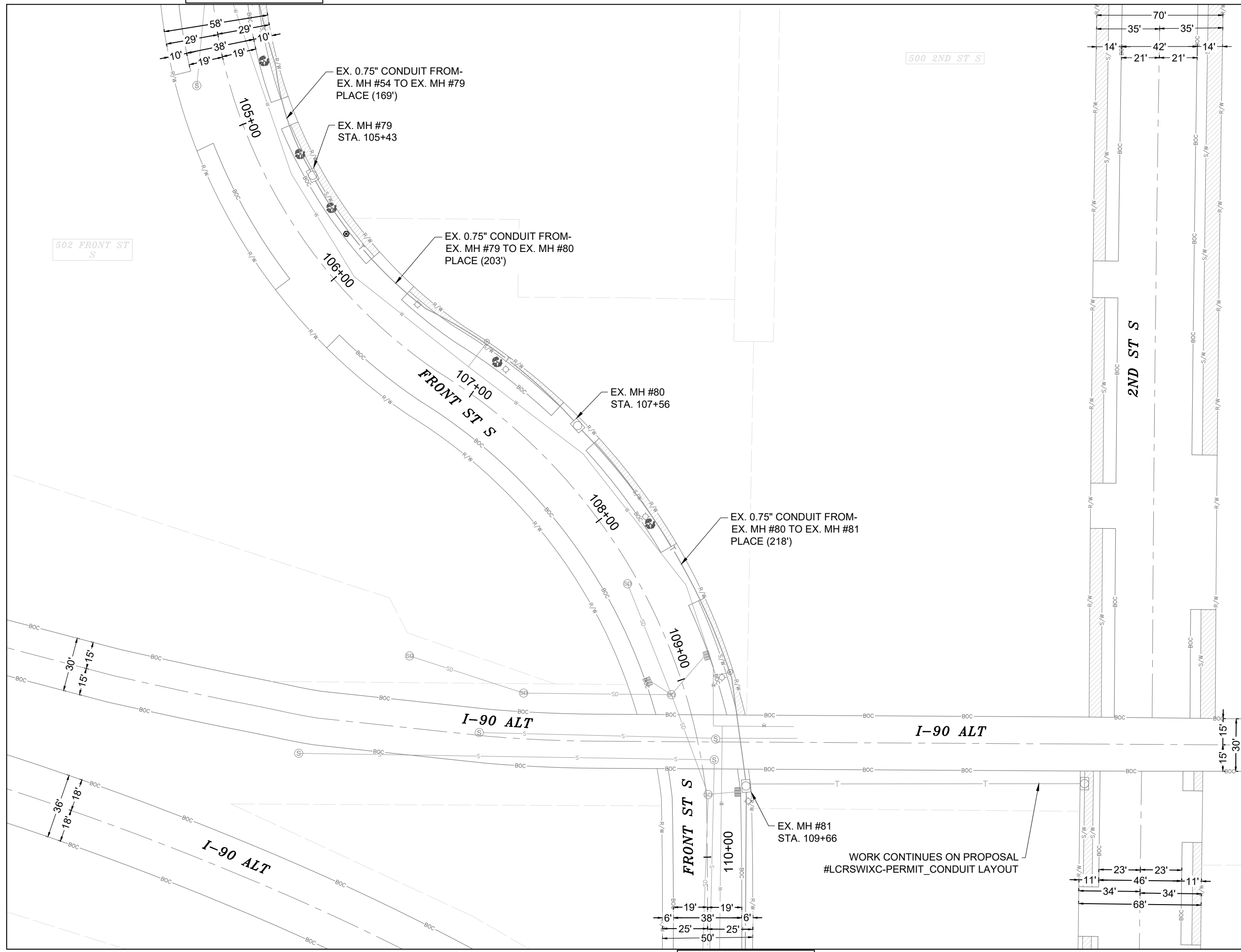

CALL 811 BEFORE YOU DIG.
 WISCONSIN TOLL FREE
 800-242-8511



CONFIDENTIAL AND PROPRIETARY
 LCRSWXC

26 OF 32
 SCALE: 1" = 50'

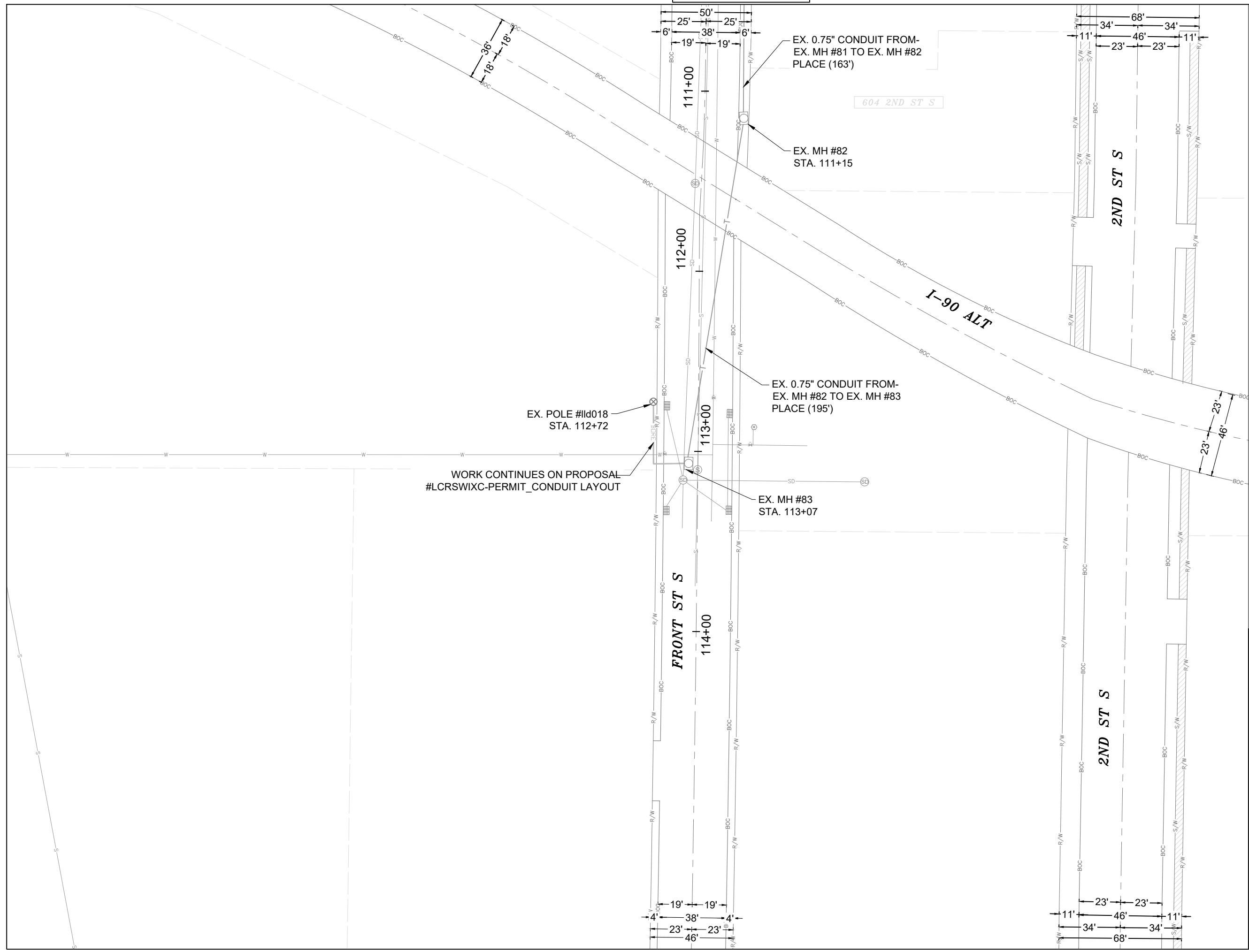
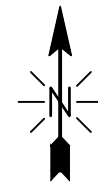

CALL 811 BEFORE YOU DIG.
WISCONSIN TOLL FREE
800-242-8511



CONFIDENTIAL AND PROPRIETARY
LCRSWIXC

27 OF 32
SCALE: 1" = 50'

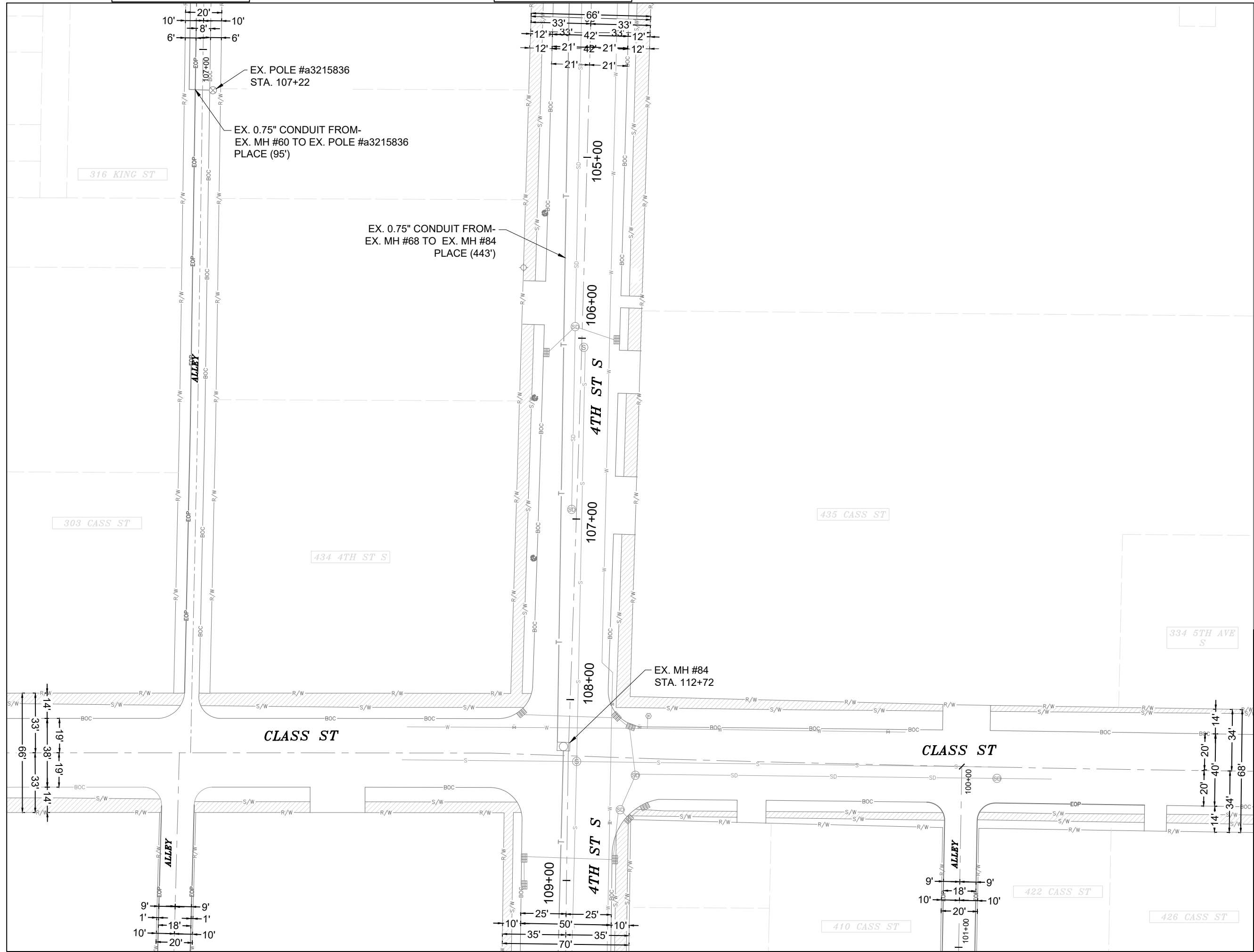
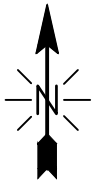

CALL 811 BEFORE YOU DIG.
 WISCONSIN TOLL FREE
 800-242-8511



CONFIDENTIAL AND PROPRIETARY
 LCRSWIXC

28 OF 32

SCALE: 1" = 50'

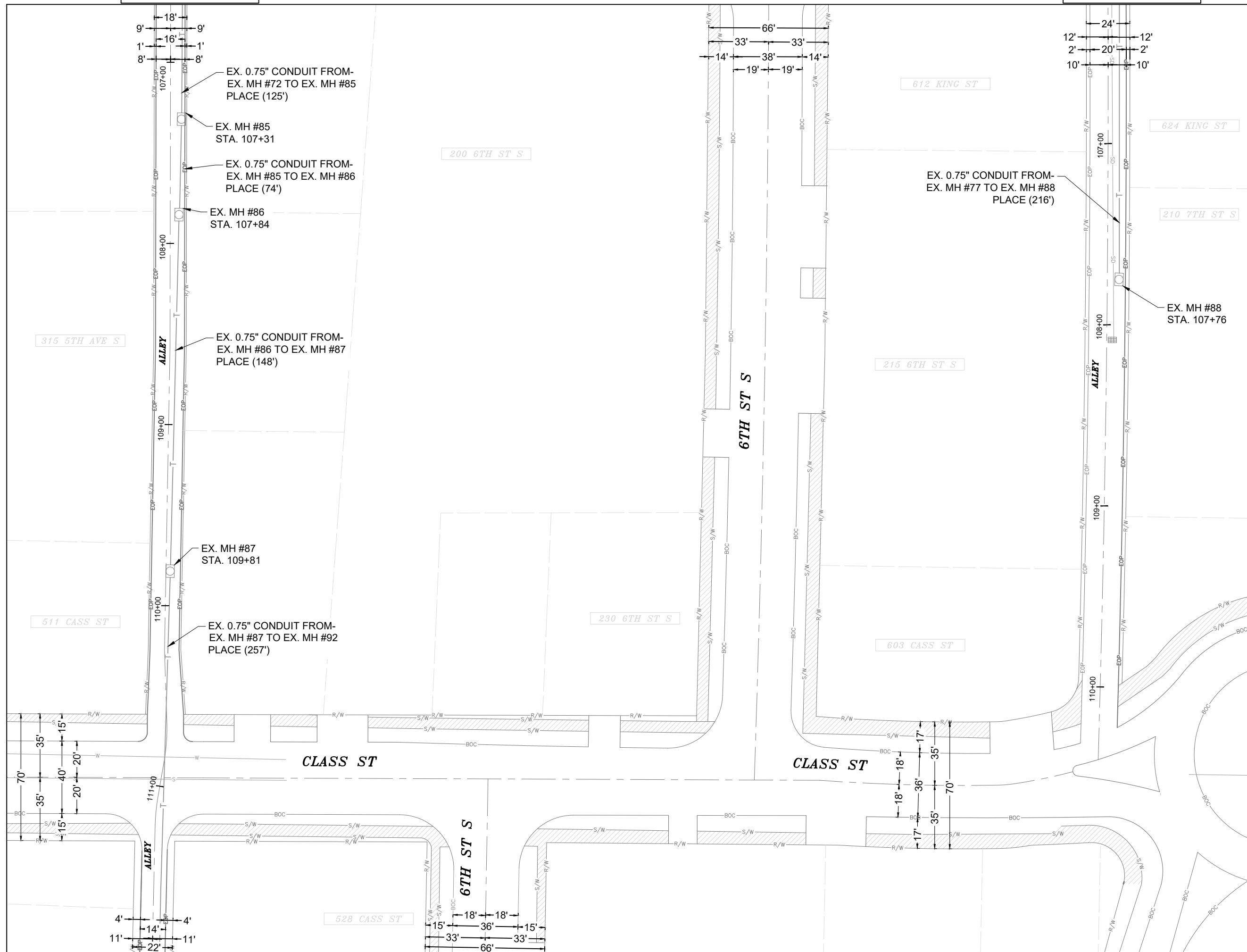
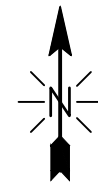

CALL 811 BEFORE YOU DIG.
 WISCONSIN TOLL FREE
 800-242-8511



CONFIDENTIAL AND PROPRIETARY
 LCRSWIXC

29 OF 32
 SCALE: 1" = 50'

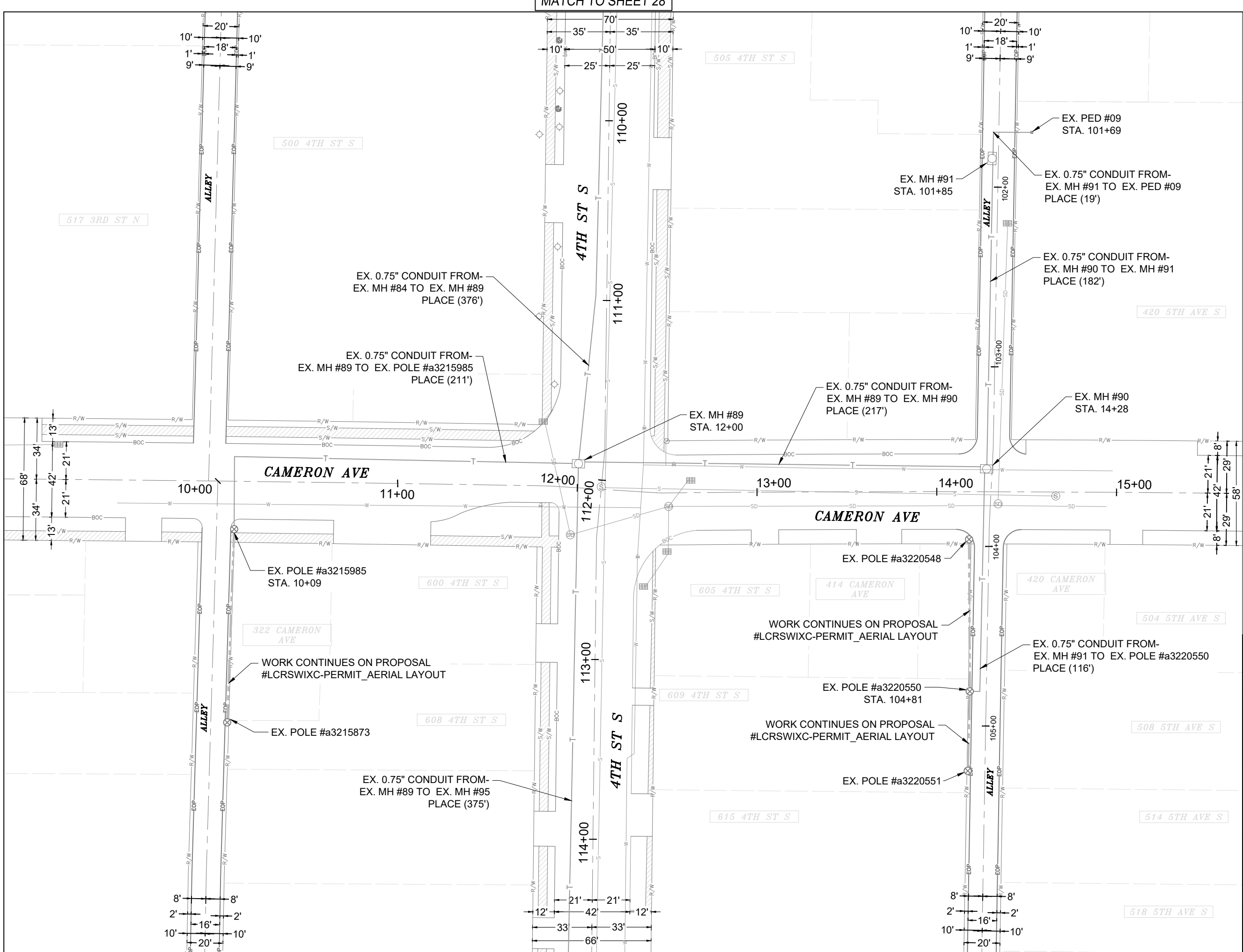
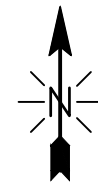

MATCH TO SHEET 28

MATCH TO SHEET 32

CALL 811 BEFORE YOU DIG.
 WISCONSIN TOLL FREE
 800-242-8511



CONFIDENTIAL AND PROPRIETARY
 LCRSWIXC

30 OF 32
 SCALE: 1" = 50'

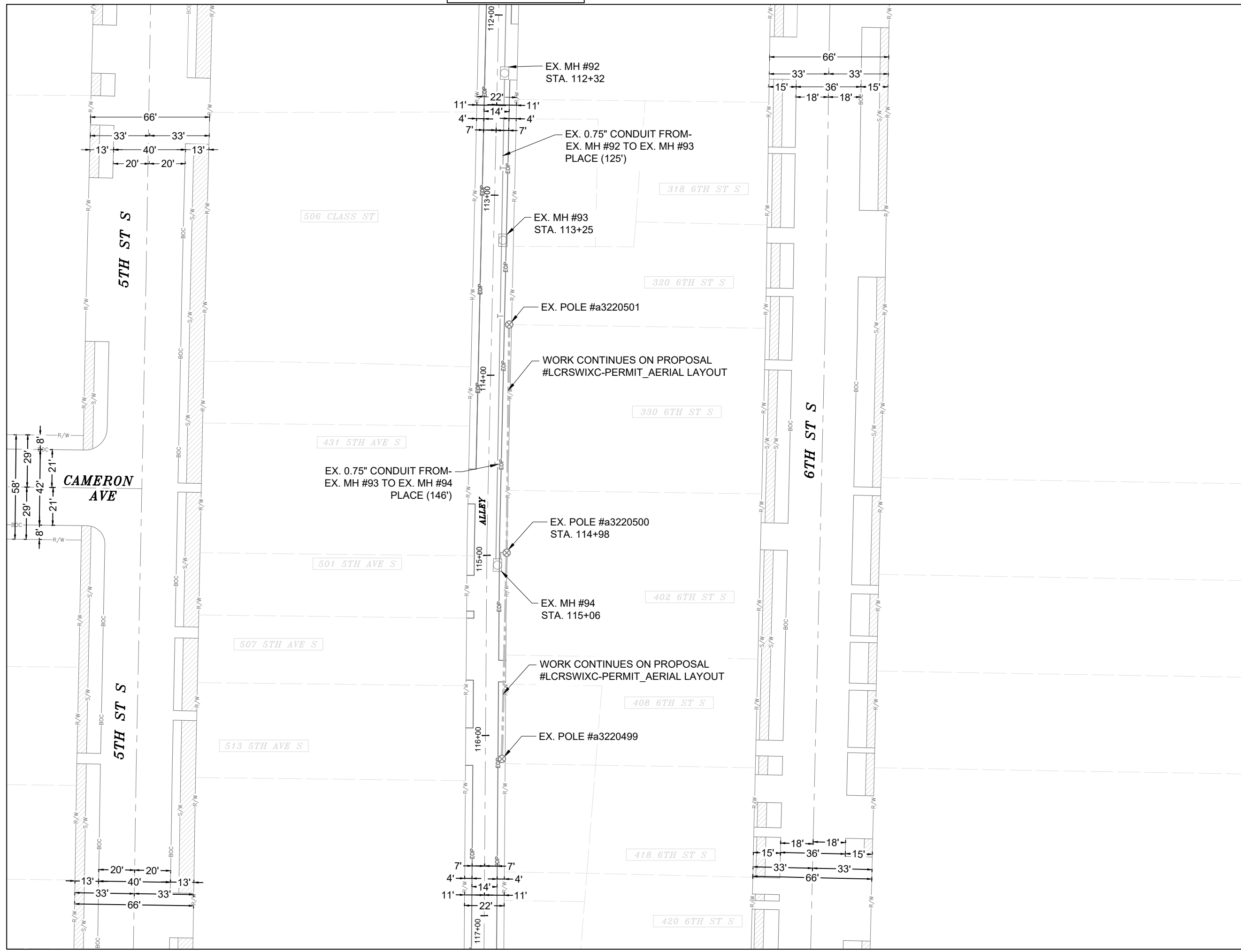
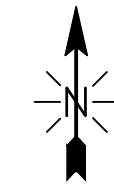

CALL 811 BEFORE YOU DIG.
 WISCONSIN TOLL FREE
 800-242-8511



CONFIDENTIAL AND PROPRIETARY
 LCRSWIXC

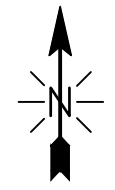
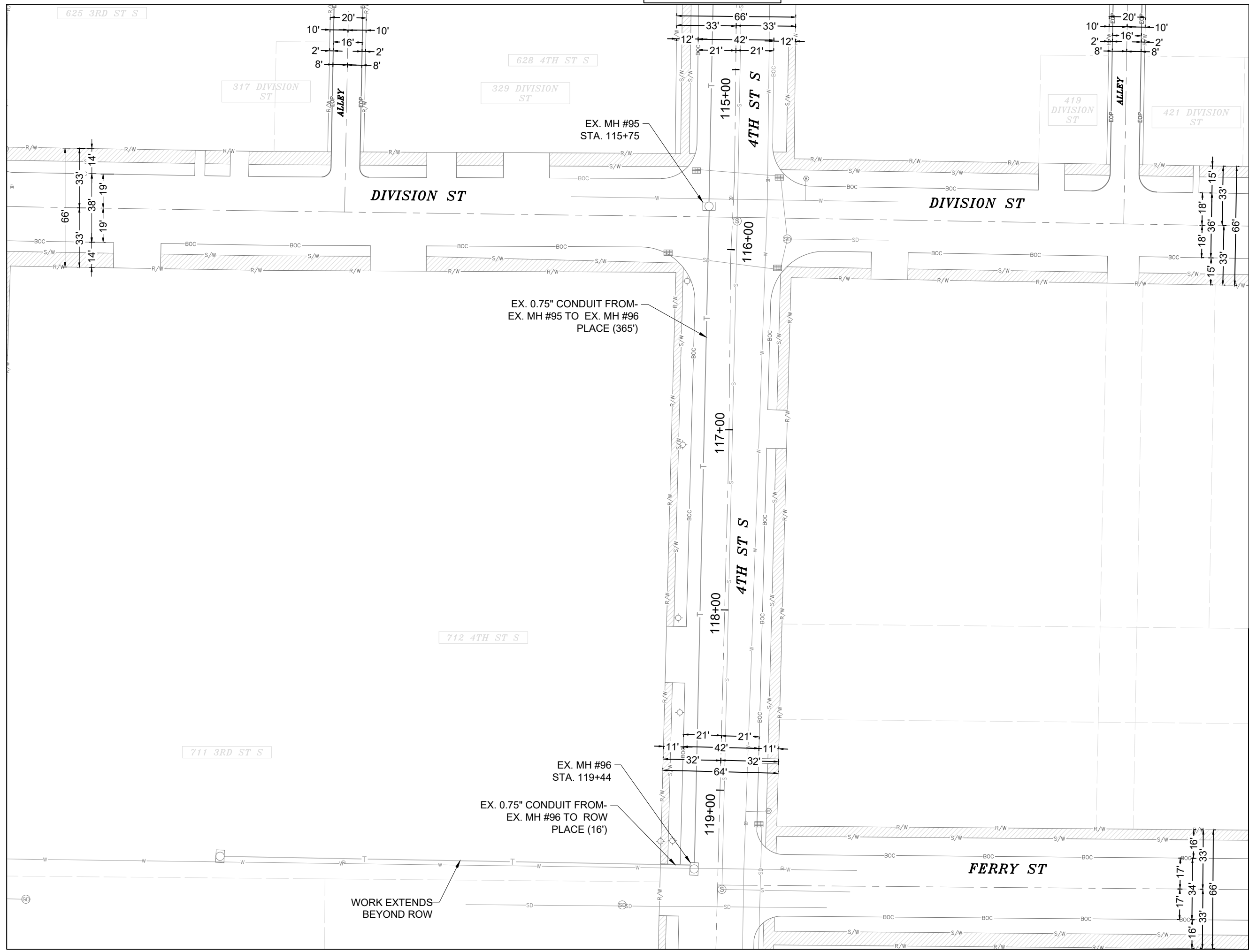

CALL 811 BEFORE YOU DIG.
 WISCONSIN TOLL FREE
 800-242-8511



CONFIDENTIAL AND PROPRIETARY
 LCRSWIXC

32 OF 32

SCALE: 1" = 50'

WORK EXTENDS
 BEYOND ROW

EX. 0.75" CONDUIT FROM-
 EX. MH #95 TO EX. MH #96
 PLACE (365')

EX. MH #96
 STA. 119+44

EX. 0.75" CONDUIT FROM-
 EX. MH #96 TO ROW
 PLACE (16')

EX. MH #95
 STA. 115+75

BRIGHTSPEED CITY OF LA CROSSE

FDP – 700 3RD ST. N. (US-53)
 3RD ST. N. (US-53) & 2ND ST. N
 LA CROSSE, WI

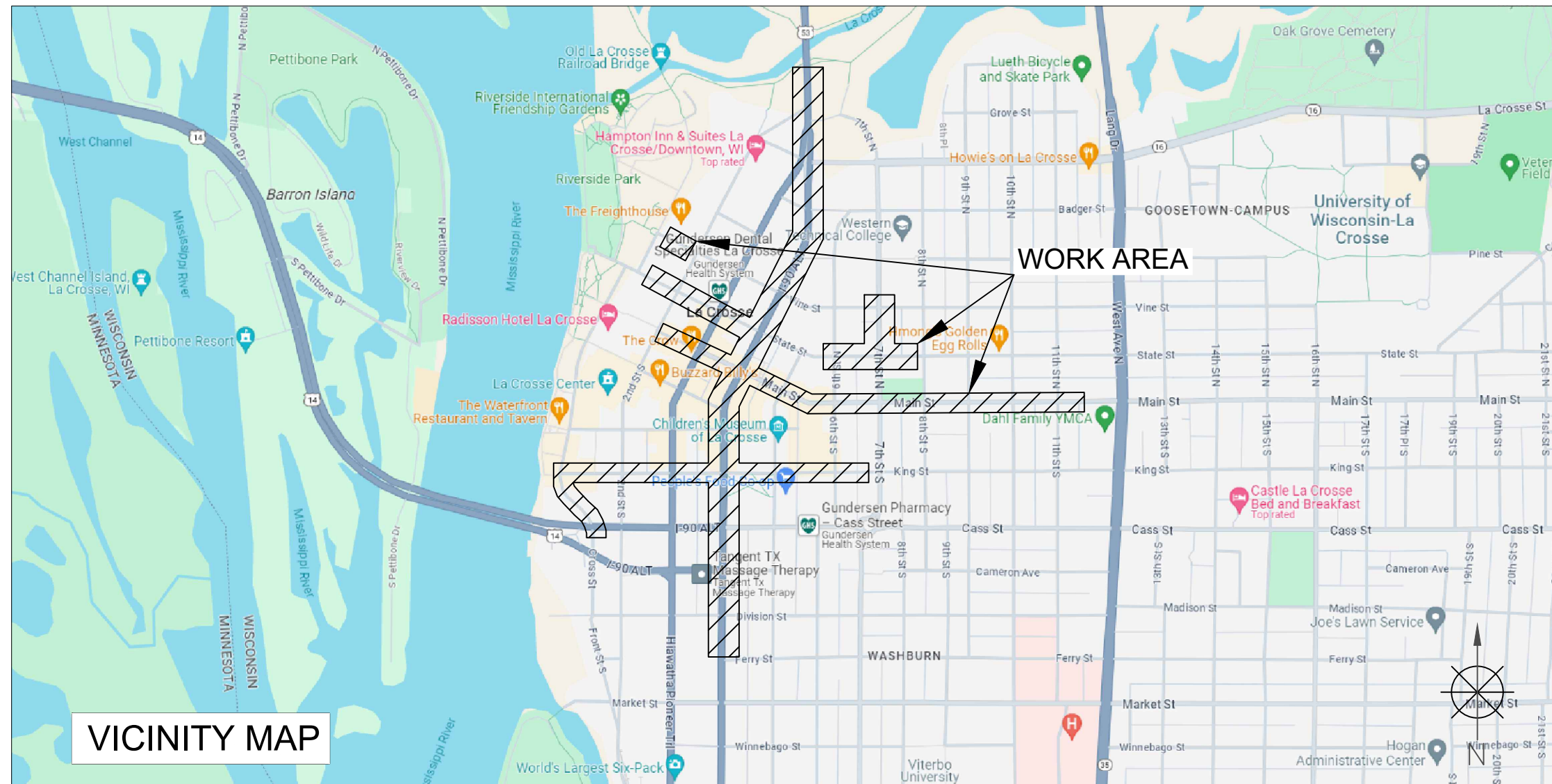

VICINITY MAP

TRAFFIC CONTROL PLAN

PERMITTING AGENCY
 CITY OF LA CROSSE



CHC
 A CONGRUEX COMPANY
 9095 Rio San Diego Dr. Ste 165
 San Diego, CA 92108-1694
 (949) 250-0004 / FAX (949) 250-0006

BRIGHTSPEED

PROPOSED PATH FOOTAGE
 UG PATH = 19,720'

REVISIONS			
REV.	DESCRIPTION	BY	DATE
0	INITIAL DESIGN	V.D.	2/20/24

LCRSWIXC

KEYMAP
 N.T.S.

SCOPE OF WORK

SHEET INDEX

ACCESS HH & PED

SHEET	DESCRIPTION
KEYMAP	VICINITY MAP & SCOPE OF WORK
TC-1 TO TC-44	TRAFFIC CONTROL PLAN

700 US-53
 I-90 ALT (US-53) & 2ND ST. N
 MH #01 ACCESS
 WORK AREA 1 OF 44

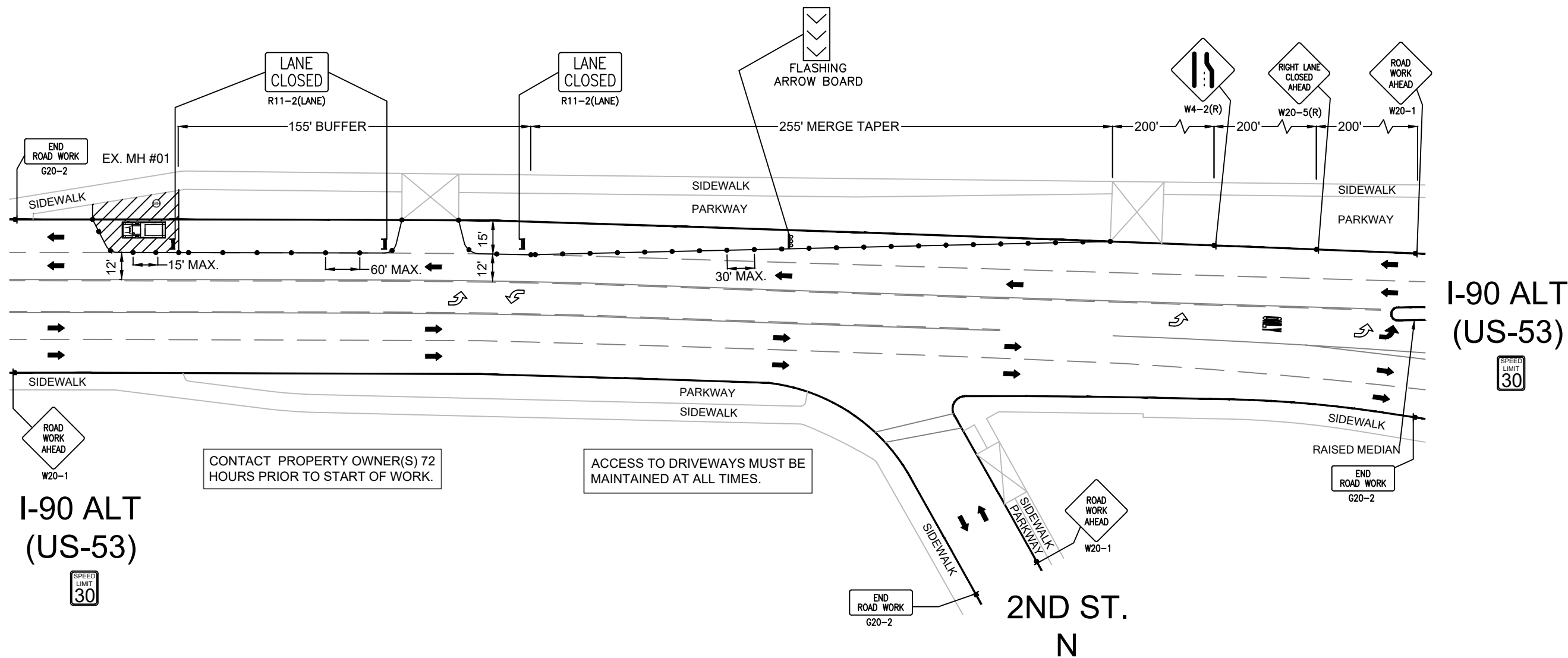

CONTACT PROPERTY OWNER(S) 72 HOURS PRIOR TO START OF WORK.

ACCESS TO DRIVEWAYS MUST BE MAINTAINED AT ALL TIMES.

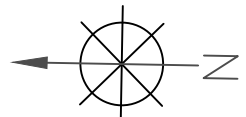

LEGEND

- * PORTABLE FLASHING BEACON (P.F.B.)
- ≡ TYPE III BARRICADE W/SIGN
- ≡ TYPE II BARRICADE W/SIGN
- CHANNELIZING DEVICE
- ▼ TRAFFIC CONE WITH CLIP ON SIGN
- TYPE I W/ SIGN
- EXISTING SIGN
- ⊙ SIGNALIZED INTERSECTION
- ⊞ FLASHING ARROW BOARD
- ⚡ HIGH LEVEL WARNING DEVICE (FLAGTREE)
- ⚠ FLAGGER
- TANSAT TOW AWAY NO STOPPING ANY TIME
- ⊞ EXISTING DRIVEWAY
- ▨ WORK ZONE (ACTIVITY AREA) LIMITS
- DIRECTION OF TRAFFIC (NOT PAVEMENT MARKING)

CALL 811 BEFORE YOU DIG.
 WISCONSIN TOLL FREE
 800-242-8511

BRIGHTSPEED

PLANS PREPARED BY:
CHC
 A CONGRUEX COMPANY
 9095 Rio San Diego Dr. Ste 165
 San Diego, CA 92108-1694
 (949) 250-0004 / FAX (949) 250-0006

REVISIONS

REV.	DESCRIPTION	BY	DATE
0	INITIAL DESIGN	V.D.	2/20/24

BRIGHTSPEED
 CONFIDENTIAL AND PROPRIETARY
 LCRSWIXC

TC-1 OF TC-44

SCALE: 1:50

**600 US-53
I-90 ALT (US-53) & LA CROSSE ST.
PED #01 ACCESS
WORK AREA 2 OF 44**

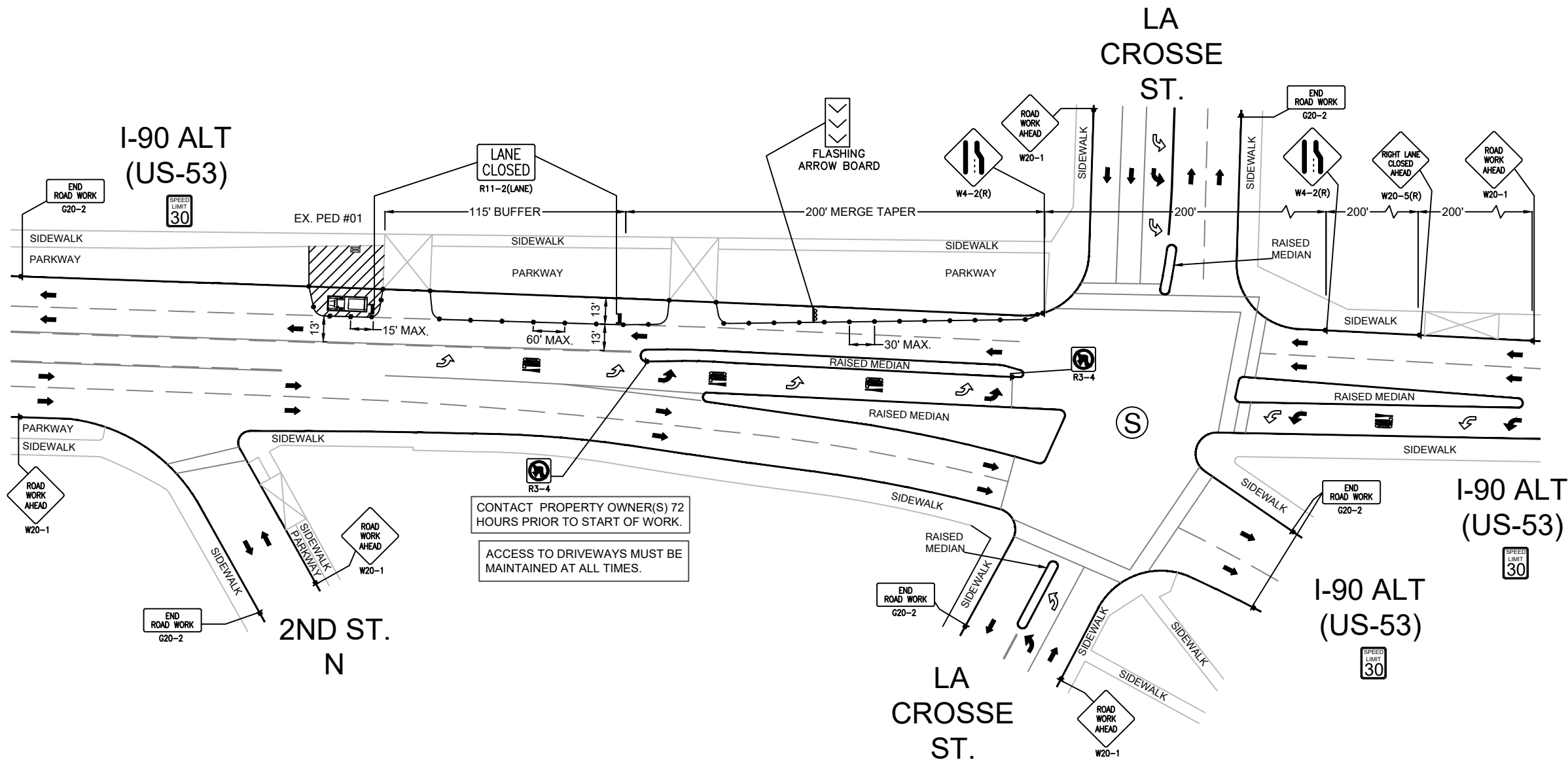

- LEGEND**
- * PORTABLE FLASHING BEACON (P.F.B.)
 - ≡ TYPE III BARRICADE W/SIGN
 - ≡ TYPE II BARRICADE W/SIGN
 - CHANNELIZING DEVICE
 - ▼ TRAFFIC CONE WITH CLIP ON SIGN
 - TYPE I W/ SIGN
 - EXISTING SIGN
 - ⊙ SIGNALIZED INTERSECTION
 - ⊞ FLASHING ARROW BOARD
 - ⚡ HIGH LEVEL WARNING DEVICE (FLAGTREE)
 - ⚓ FLAGGER
 - TANSAT TOW AWAY NO STOPPING ANY TIME
 - ⊞ EXISTING DRIVEWAY
 - ▨ WORK ZONE (ACTIVITY AREA) LIMITS
 - DIRECTION OF TRAFFIC (NOT PAVEMENT MARKING)

CALL 811 BEFORE YOU DIG.
WISCONSIN TOLL FREE
800-242-8511

BRIGHTSPEED

PLANS PREPARED BY:
XCHC
A CONGRUEX COMPANY
9095 Rio San Diego Dr. Ste 165
San Diego, CA 92108-1694
(949) 250-0004 / FAX (949) 250-0006

REVISIONS			
REV.	DESCRIPTION	BY	DATE
0	INITIAL DESIGN	V.D.	2/20/24

BRIGHTSPEED
CONFIDENTIAL AND PROPRIETARY
LCRSWIXC

TC-2 OF TC-44

SCALE: 1:60

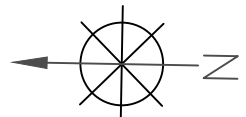

**350 4TH ST. N (I-90 ALT.-US-53)
 4TH ST. N (I-90 ALT.-US-53) & BADGER ST.
 MH #02 ACCESS
 WORK AREA 3 OF 44**

**I-90 ALT
 (US-53)**
 SPEED
 LIMIT
 25

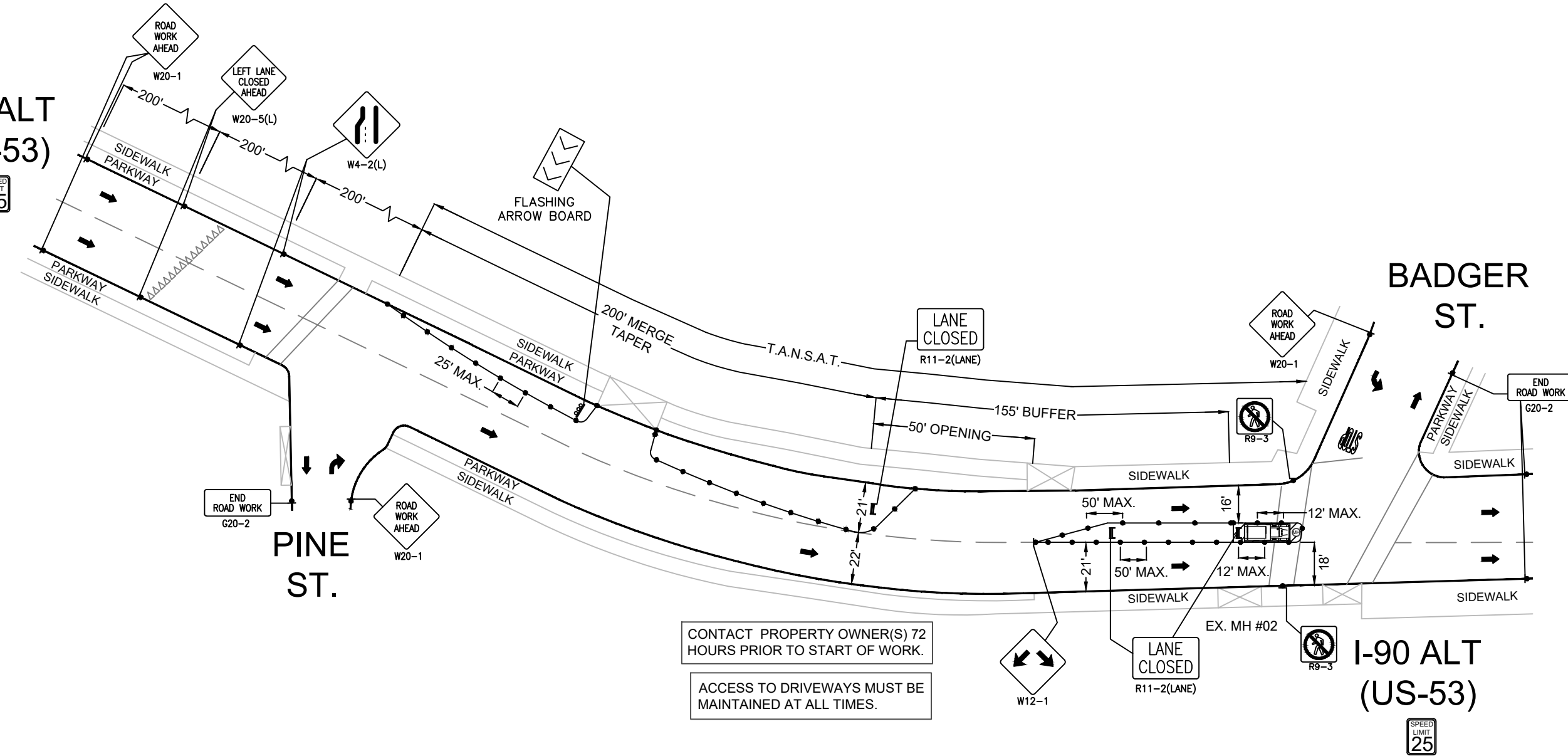

CONTACT PROPERTY OWNER(S) 72 HOURS PRIOR TO START OF WORK.
 ACCESS TO DRIVEWAYS MUST BE MAINTAINED AT ALL TIMES.

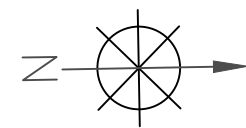

LEGEND

- * PORTABLE FLASHING BEACON (P.F.B.)
- ≡ TYPE III BARRICADE W/SIGN
- ≡ TYPE II BARRICADE W/SIGN
- CHANNELIZING DEVICE
- ▼ TRAFFIC CONE WITH CLIP ON SIGN
- TYPE I W/ SIGN
- EXISTING SIGN
- ⊙ SIGNALIZED INTERSECTION
- ⊞ FLASHING ARROW BOARD
- ⚡ HIGH LEVEL WARNING DEVICE (FLAGTREE)
- ⚠ FLAGGER
- TANSAT TOW AWAY NO STOPPING ANY TIME
- ⊞ EXISTING DRIVEWAY
- ▨ WORK ZONE (ACTIVITY AREA) LIMITS
- DIRECTION OF TRAFFIC (NOT PAVEMENT MARKING)

CALL 811 BEFORE YOU DIG.
 WISCONSIN TOLL FREE
 800-242-8511

BRIGHTSPEED

PLANS PREPARED BY:
CHC
 A CONGRUEX COMPANY
 9095 Rio San Diego Dr. Ste 165
 San Diego, CA 92108-1694
 (949) 250-0004 / FAX (949) 250-0006

REVISIONS			
REV.	DESCRIPTION	BY	DATE
0	INITIAL DESIGN	V.D.	2/20/24

BRIGHTSPEED
 CONFIDENTIAL AND PROPRIETARY
 LCRSWIXC

TC-3 OF TC-44

SCALE: 1:50

351 4TH ST. N (I-90 ALT.-US-53)
 4TH ST. N (I-90 ALT.-US-53) & VINE ST.
 MH #03 ACCESS
 WORK AREA 4 OF 44

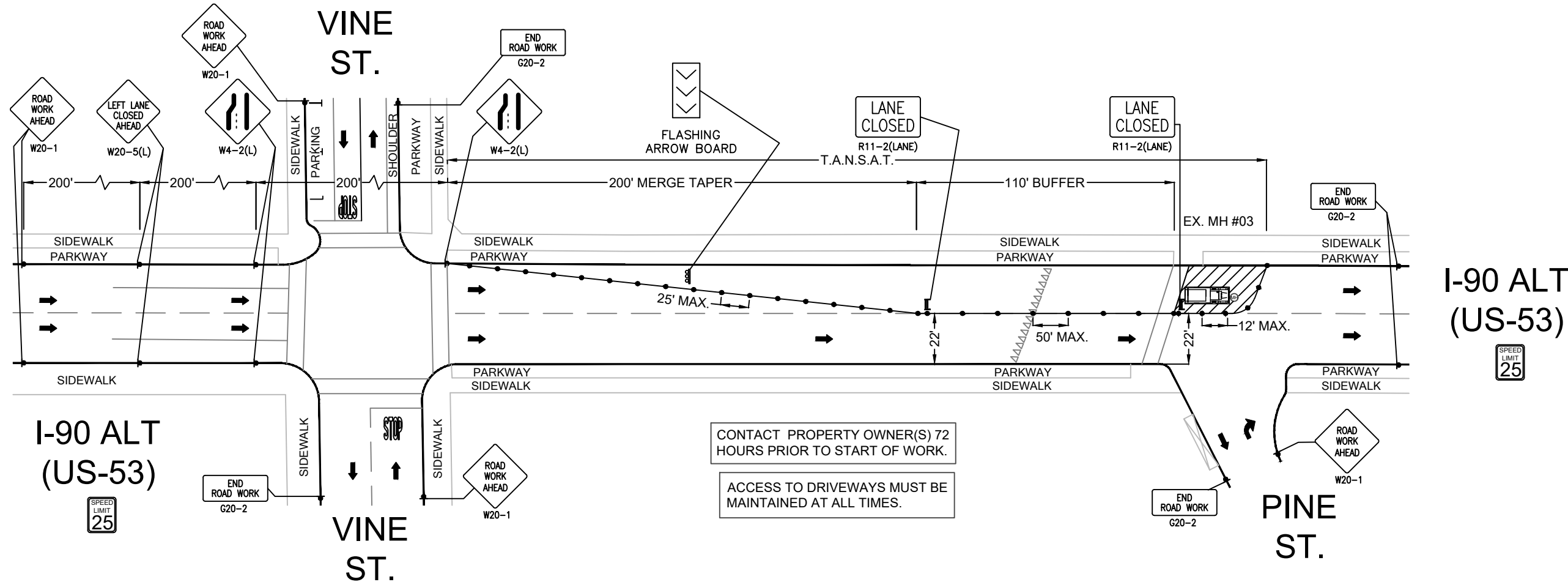

CONTACT PROPERTY OWNER(S) 72 HOURS PRIOR TO START OF WORK.
 ACCESS TO DRIVEWAYS MUST BE MAINTAINED AT ALL TIMES.

- LEGEND**
- * PORTABLE FLASHING BEACON (P.F.B.)
 - ≡ TYPE III BARRICADE W/SIGN
 - ≡ TYPE II BARRICADE W/SIGN
 - CHANNELIZING DEVICE
 - ▼ TRAFFIC CONE WITH CLIP ON SIGN
 - TYPE I W/ SIGN
 - EXISTING SIGN
 - ⊙ SIGNALIZED INTERSECTION
 - ⊞ FLASHING ARROW BOARD
 - ⚡ HIGH LEVEL WARNING DEVICE (FLAGTREE)
 - ⚓ FLAGGER
 - TANSAT TOW AWAY NO STOPPING ANY TIME
 - ⊞ EXISTING DRIVEWAY
 - ▨ WORK ZONE (ACTIVITY AREA) LIMITS
 - ➔ DIRECTION OF TRAFFIC (NOT PAVEMENT MARKING)

CALL 811 BEFORE YOU DIG.
 WISCONSIN TOLL FREE
 800-242-8511

BRIGHTSPEED

PLANS PREPARED BY:

CHC
 A CONGRUEX COMPANY
 9095 Rio San Diego Dr. Ste 165
 San Diego, CA 92108-1694
 (949) 250-0004 / FAX (949) 250-0006

REVISIONS			
REV.	DESCRIPTION	BY	DATE
0	INITIAL DESIGN	V.D.	2/20/24

BRIGHTSPEED
 CONFIDENTIAL AND PROPRIETARY

LCRSWIXC

TC-4 OF TC-44

SCALE: 1:50

323 STATE ST.
 4TH ST. N (I-90 ALT.-US-53) & STATE ST.
 MH #04 ACCESS
 WORK AREA 5 OF 44

I-90 ALT
 (US-53) SPEED LIMIT 25

STATE ST.

STATE ST.

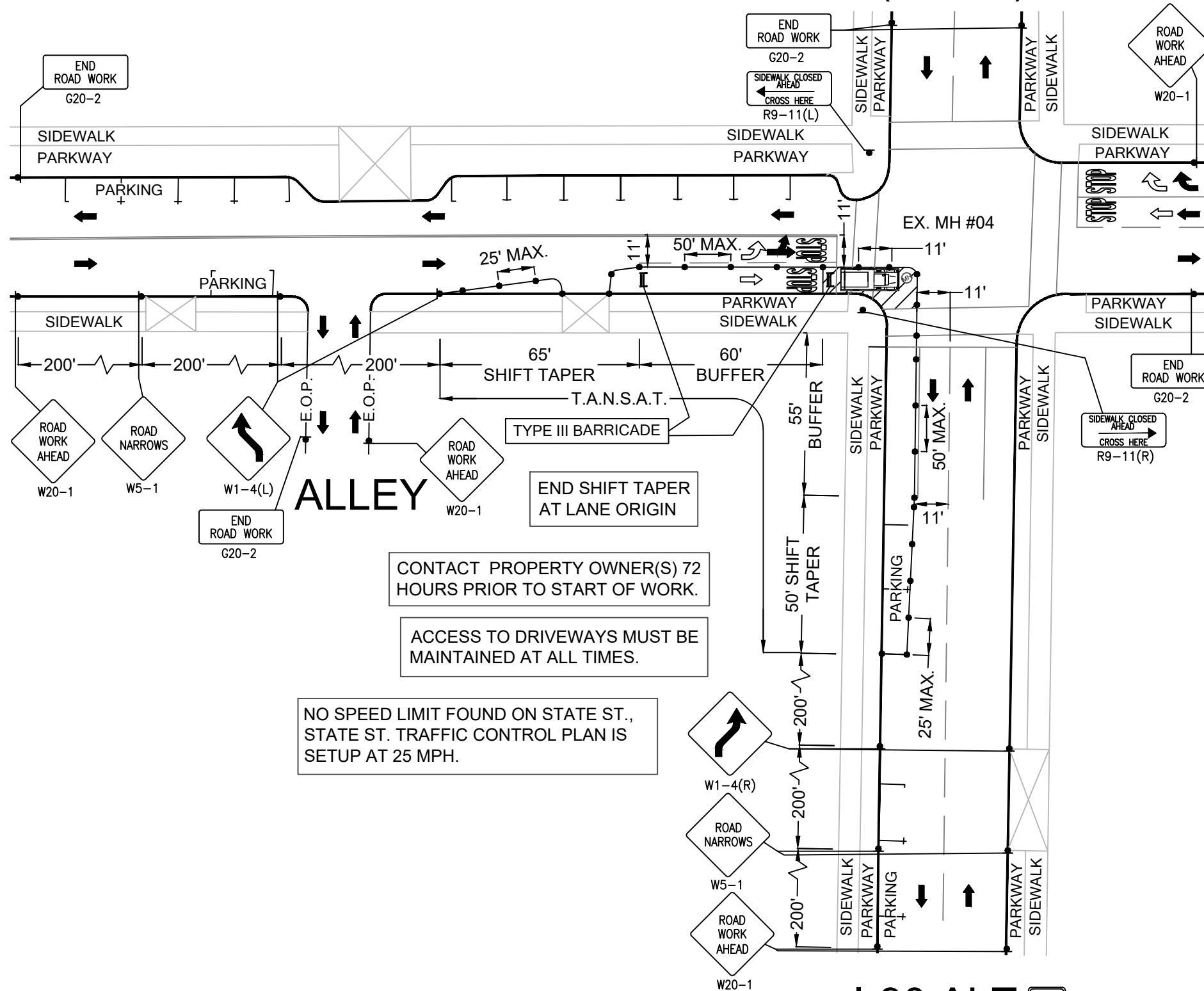

CONTACT PROPERTY OWNER(S) 72 HOURS PRIOR TO START OF WORK.

ACCESS TO DRIVEWAYS MUST BE MAINTAINED AT ALL TIMES.

NO SPEED LIMIT FOUND ON STATE ST., STATE ST. TRAFFIC CONTROL PLAN IS SETUP AT 25 MPH.

LEGEND

- * PORTABLE FLASHING BEACON (P.F.B.)
- ▬ TYPE III BARRICADE W/SIGN
- ⋈ TYPE II BARRICADE W/SIGN
- CHANNELIZING DEVICE
- ▼ TRAFFIC CONE WITH CLIP ON SIGN
- ▬ TYPE I W/ SIGN
- ▭ EXISTING SIGN
- ⊙ SIGNALIZED INTERSECTION
- ⚡ FLASHING ARROW BOARD
- ⚡ HIGH LEVEL WARNING DEVICE (FLAGTREE)
- ⚡ FLAGGER
- TANSAT TOW AWAY NO STOPPING ANY TIME
- ▭ EXISTING DRIVEWAY
- ▨ WORK ZONE (ACTIVITY AREA) LIMITS
- DIRECTION OF TRAFFIC (NOT PAVEMENT MARKING)

CALL 811 BEFORE YOU DIG.
 WISCONSIN TOLL FREE
 800-242-8511

BRIGHTSPEED

PLANS PREPARED BY:
CHC
 A CONGRUEX COMPANY
 9095 Rio San Diego Dr. Ste 165
 San Diego, CA 92108-1694
 (949) 250-0004 / FAX (949) 250-0006

REVISIONS			
REV.	DESCRIPTION	BY	DATE
0	INITIAL DESIGN	V.D.	2/20/24

BRIGHTSPEED
 CONFIDENTIAL AND PROPRIETARY
 LCRSWIXC

TC-5 OF TC-44

SCALE: 1:40

404 4TH ST. S (I-90 ALT.-US-53)
 4TH ST. N (I-90 ALT.-US-53) & KING ST.
 MH #68 ACCESS
 WORK AREA 6 OF 44

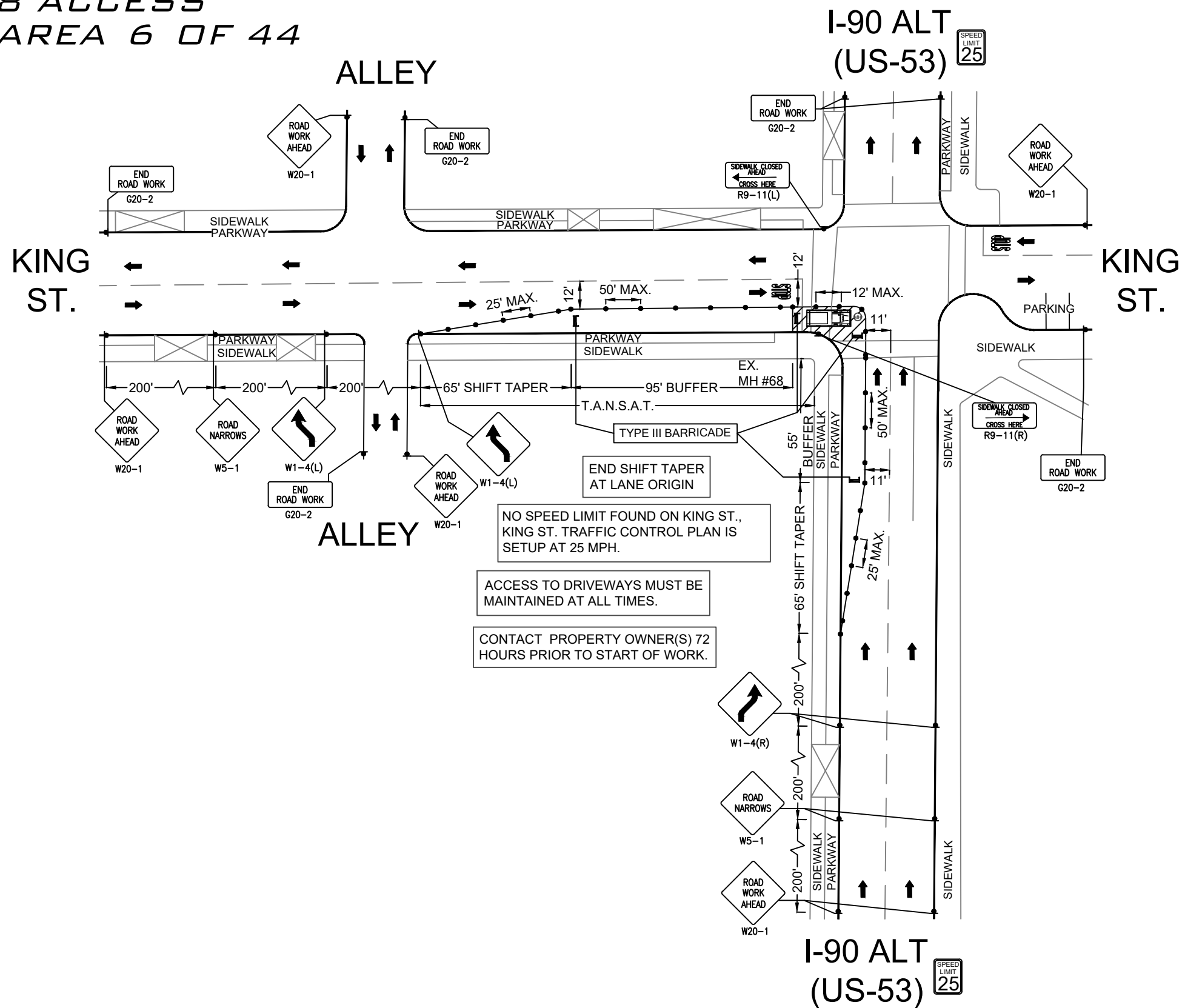

LEGEND

- * PORTABLE FLASHING BEACON (P.F.B.)
- ≡ TYPE III BARRICADE W/SIGN
- ≡ TYPE II BARRICADE W/SIGN
- CHANNELIZING DEVICE
- ▼ TRAFFIC CONE WITH CLIP ON SIGN
- TYPE I W/ SIGN
- EXISTING SIGN
- ⊙ SIGNALIZED INTERSECTION
- ⊞ FLASHING ARROW BOARD
- ⚡ HIGH LEVEL WARNING DEVICE (FLAGTREE)
- ⚠ FLAGGER
- TANSAT TOW AWAY NO STOPPING ANY TIME
- ⊞ EXISTING DRIVEWAY
- ▨ WORK ZONE (ACTIVITY AREA) LIMITS
- DIRECTION OF TRAFFIC (NOT PAVEMENT MARKING)

CALL 811 BEFORE YOU DIG.
 WISCONSIN TOLL FREE
 800-242-8511

BRIGHTSPEED

PLANS PREPARED BY:
CHC
 A CONGRUEX COMPANY
 9095 Rio San Diego Dr. Ste 165
 San Diego, CA 92108-1694
 (949) 250-0004 / FAX (949) 250-0006

REVISIONS

REV.	DESCRIPTION	BY	DATE
0	INITIAL DESIGN	V.D.	2/20/24

BRIGHTSPEED
 CONFIDENTIAL AND PROPRIETARY
 LCRSWIXC

TC-6 OF TC-44

SCALE: 1:50

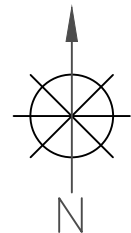

435 CASS ST. 4TH ST. N (I-90 ALT.-US-53) & CASS ST. MH #84 ACCESS WORK AREA 7 OF 44

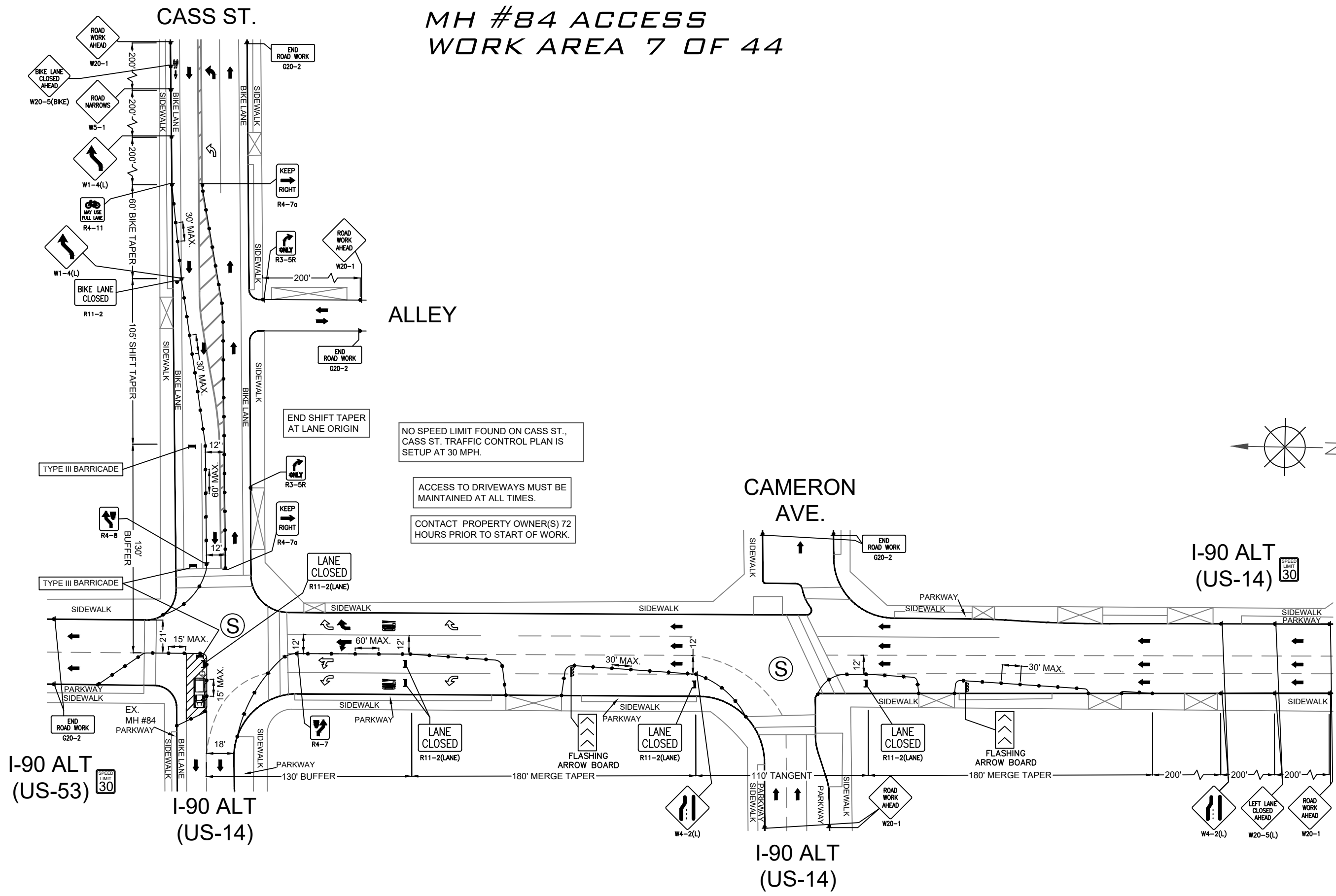

NO SPEED LIMIT FOUND ON CASS ST.,
CASS ST. TRAFFIC CONTROL PLAN IS
SETUP AT 30 MPH.

ACCESS TO DRIVEWAYS MUST BE
MAINTAINED AT ALL TIMES.

CONTACT PROPERTY OWNER(S) 72
HOURS PRIOR TO START OF WORK.

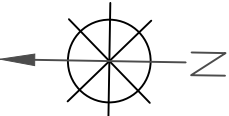

LEGEND

- * PORTABLE FLASHING BEACON (P.F.B.)
- ≡ TYPE III BARRICADE W/SIGN
- ⋈ TYPE II BARRICADE W/SIGN
- CHANNELIZING DEVICE
- ▼ TRAFFIC CONE WITH CLIP ON SIGN
- TYPE I W/ SIGN
- EXISTING SIGN
- Ⓢ SIGNALIZED INTERSECTION
- ⚡ FLASHING ARROW BOARD
- ⚡ HIGH LEVEL WARNING DEVICE (FLAGTREE)
- ♠ FLAGGER
- TANSAT TOW AWAY NO STOPPING ANY TIME
- ⊠ EXISTING DRIVEWAY
- ▨ WORK ZONE (ACTIVITY AREA) LIMITS
- DIRECTION OF TRAFFIC (NOT PAVEMENT MARKING)

CALL 811 BEFORE YOU DIG.
WISCONSIN TOLL FREE
800-242-8511

BRIGHTSPEED

PLANS PREPARED BY:
XCHC
 A CONGRUEX COMPANY
 9095 Rio San Diego Dr. Ste 165
 San Diego, CA 92108-1694
 (949) 250-0004 / FAX (949) 250-0006

REVISIONS			
REV.	DESCRIPTION	BY	DATE
0	INITIAL DESIGN	V.D.	2/20/24

BRIGHTSPEED
CONFIDENTIAL AND PROPRIETARY

LCRSWIXC

TC-7 OF TC-44

SCALE: 1:60

LEGEND

- * PORTABLE FLASHING BEACON (P.F.B.)
- ▬ TYPE III BARRICADE W/SIGN
- ⋈ TYPE II BARRICADE W/SIGN
- CHANNELIZING DEVICE
- ▼ TRAFFIC CONE WITH CLIP ON SIGN
- ▬ TYPE I W/ SIGN
- ▭ EXISTING SIGN
- ⊙ SIGNALIZED INTERSECTION
- ⚡ FLASHING ARROW BOARD
- ⚡ HIGH LEVEL WARNING DEVICE (FLAGTREE)
- ⚡ FLAGGER
- TANSAT TOW AWAY NO STOPPING ANY TIME
- ▭ EXISTING DRIVEWAY
- ▨ WORK ZONE (ACTIVITY AREA) LIMITS
- ➔ DIRECTION OF TRAFFIC (NOT PAVEMENT MARKING)

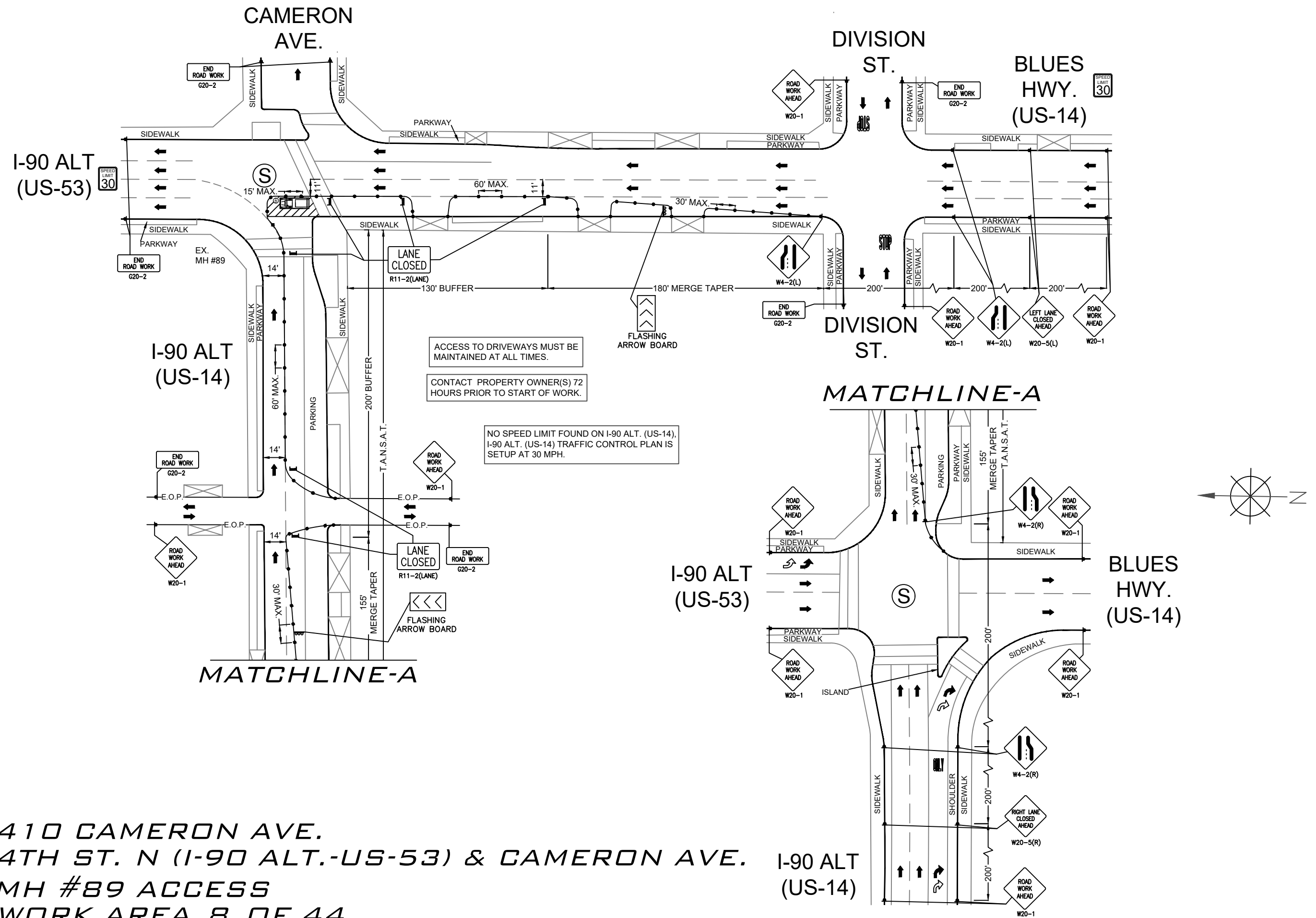

**410 CAMERON AVE.
 4TH ST. N (I-90 ALT.-US-53) & CAMERON AVE.
 MH #89 ACCESS
 WORK AREA 8 OF 44**

CALL 811 BEFORE YOU DIG.
 WISCONSIN TOLL FREE
 800-242-8511

BRIGHTSPEED

PLANS PREPARED BY:
XCHC
 A CONGRUEX COMPANY
 9095 Rio San Diego Dr. Ste 165
 San Diego, CA 92108-1694
 (949) 250-0004 / FAX (949) 250-0006

REVISIONS			
REV.	DESCRIPTION	BY	DATE
0	INITIAL DESIGN	V.D.	2/20/24

BRIGHTSPEED
 CONFIDENTIAL AND PROPRIETARY
 LCRSWIXC

TC-8 OF TC-44

SCALE: 1:60

323 DIVISION ST. 4TH ST. N (BLUES HWY.-US-53) & DIVISION ST. MH #95 ACCESS WORK AREA 9 OF 44

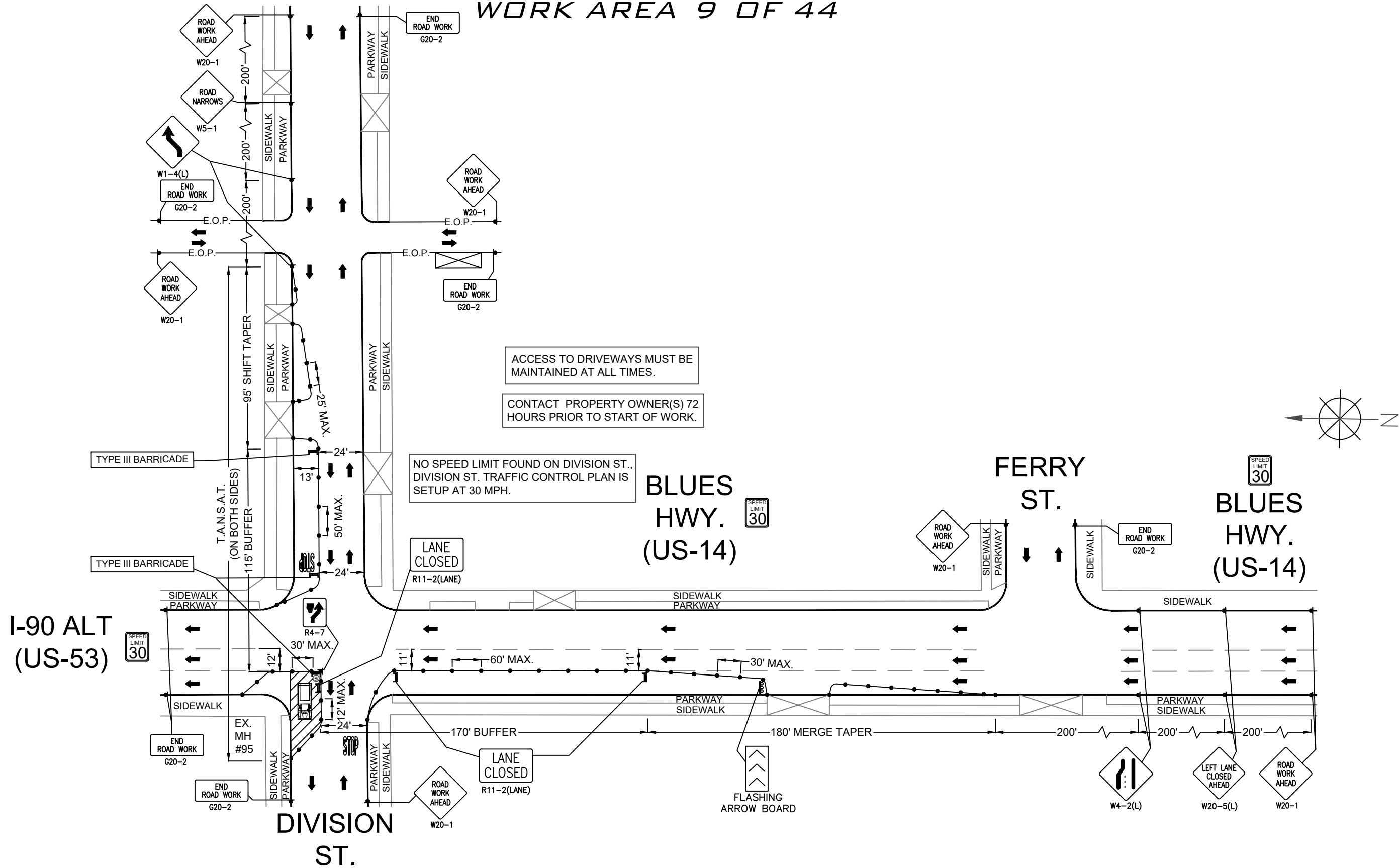

ACCESS TO DRIVEWAYS MUST BE MAINTAINED AT ALL TIMES.

CONTACT PROPERTY OWNER(S) 72 HOURS PRIOR TO START OF WORK.

NO SPEED LIMIT FOUND ON DIVISION ST.,
DIVISION ST. TRAFFIC CONTROL PLAN IS
SETUP AT 30 MPH.

LEGEND

- * PORTABLE FLASHING BEACON (P.F.B.)
- ≡ TYPE III BARRICADE W/SIGN
- ⋈ TYPE II BARRICADE W/SIGN
- CHANNELIZING DEVICE
- ▼ TRAFFIC CONE WITH CLIP ON SIGN
- ▬ TYPE I W/ SIGN
- EXISTING SIGN
- Ⓢ SIGNALIZED INTERSECTION
- ⚡ FLASHING ARROW BOARD
- ⚡ HIGH LEVEL WARNING DEVICE (FLAGTREE)
- ⚡ FLAGGER
- TANSAT TOW AWAY NO STOPPING ANY TIME
- ⊠ EXISTING DRIVEWAY
- ▨ WORK ZONE (ACTIVITY AREA) LIMITS
- ➔ DIRECTION OF TRAFFIC (NOT PAVEMENT MARKING)

CALL 811 BEFORE YOU DIG.
WISCONSIN TOLL FREE
800-242-8511

BRIGHTSPEED

PLANS PREPARED BY:
XCHC
A CONGRUEX COMPANY
9095 Rio San Diego Dr. Ste 165
San Diego, CA 92108-1694
(949) 250-0004 / FAX (949) 250-0006

REVISIONS			
REV.	DESCRIPTION	BY	DATE
0	INITIAL DESIGN	V.D.	2/20/24

BRIGHTSPEED
CONFIDENTIAL AND PROPRIETARY
LCRSWIXC

TC-9 OF TC-44

419 FERRY ST.
 4TH ST. N (BLUES HWY.-US-53) & FERRY ST.
 MH #96 ACCESS
 WORK AREA 10 OF 44

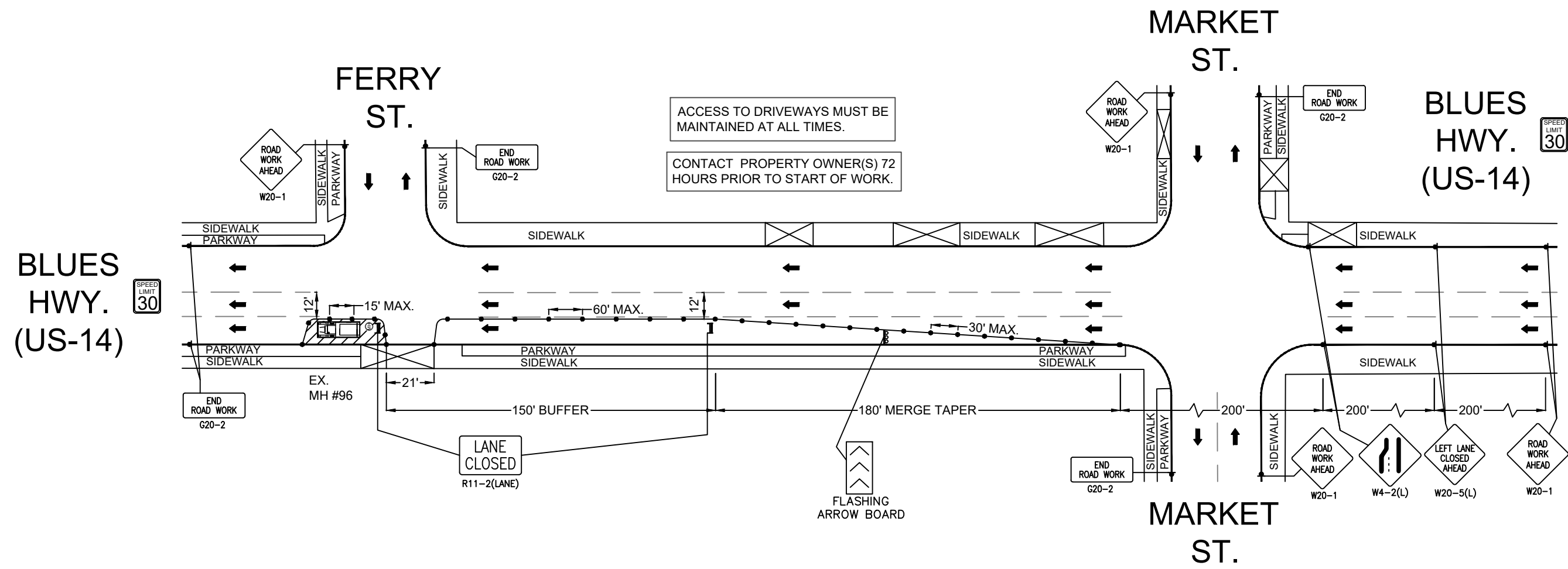

LEGEND

- * PORTABLE FLASHING BEACON (P.F.B.)
- ≡ TYPE III BARRICADE W/SIGN
- ≡ TYPE II BARRICADE W/SIGN
- CHANNELIZING DEVICE
- ▼ TRAFFIC CONE WITH CLIP ON SIGN
- TYPE I W/ SIGN
- EXISTING SIGN
- ⊙ SIGNALIZED INTERSECTION
- ⚡ FLASHING ARROW BOARD
- ⚡ HIGH LEVEL WARNING DEVICE (FLAGTREE)
- ⚡ FLAGGER
- TANSAT TOW AWAY NO STOPPING ANY TIME
- ⊠ EXISTING DRIVEWAY
- ▨ WORK ZONE (ACTIVITY AREA) LIMITS
- DIRECTION OF TRAFFIC (NOT PAVEMENT MARKING)

CALL 811 BEFORE YOU DIG.
 WISCONSIN TOLL FREE
 800-242-8511

BRIGHTSPEED

PLANS PREPARED BY:
CHC
 A CONGRUEX COMPANY
 9095 Rio San Diego Dr. Ste 165
 San Diego, CA 92108-1694
 (949) 250-0004 / FAX (949) 250-0006

REVISIONS

REV.	DESCRIPTION	BY	DATE
0	INITIAL DESIGN	V.D.	2/20/24

BRIGHTSPEED
 CONFIDENTIAL AND PROPRIETARY
 LCRSWIXC

TC-10 OF TC-44

SCALE: 1:50

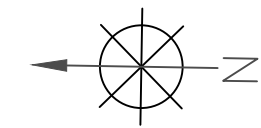

3307 2ND ST. N
 2ND ST. N & VINE ST.
 MH #15 ACCESS
 WORK AREA 11 OF 44

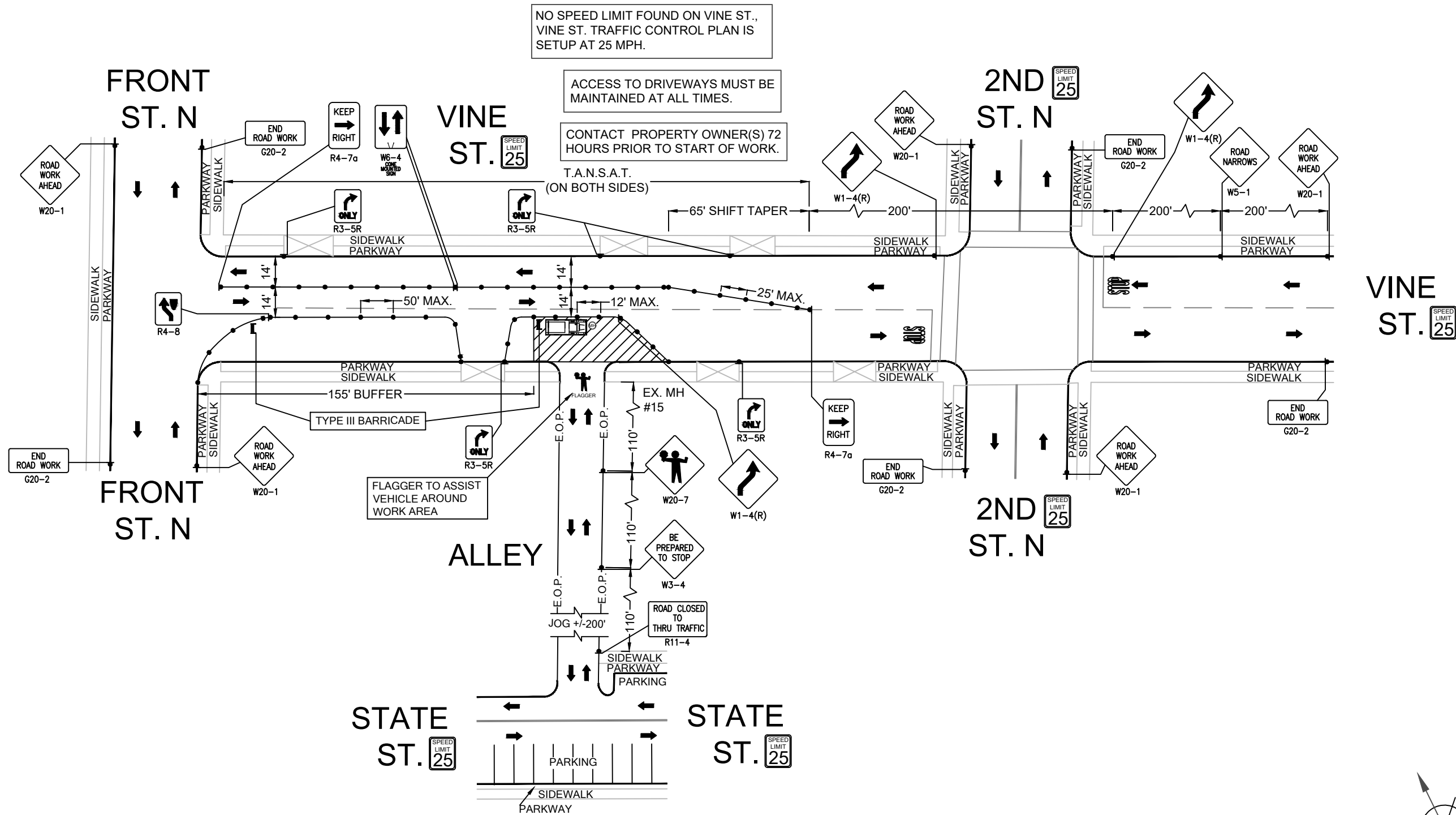

NO SPEED LIMIT FOUND ON VINE ST.,
 VINE ST. TRAFFIC CONTROL PLAN IS
 SETUP AT 25 MPH.

ACCESS TO DRIVEWAYS MUST BE
 MAINTAINED AT ALL TIMES.

CONTACT PROPERTY OWNER(S) 72
 HOURS PRIOR TO START OF WORK.

T.A.N.S.A.T.
 (ON BOTH SIDES)

FLAGGER TO ASSIST
 VEHICLE AROUND
 WORK AREA

LEGEND

- * PORTABLE FLASHING BEACON (P.F.B.)
- ≡ TYPE III BARRICADE W/SIGN
- ⋈ TYPE II BARRICADE W/SIGN
- CHANNELIZING DEVICE
- ⚡ TRAFFIC CONE WITH CLIP ON SIGN
- ▬ TYPE I W/ SIGN
- ◻ EXISTING SIGN
- ⊙ SIGNALIZED INTERSECTION
- ⚡ FLASHING ARROW BOARD
- ⚡ HIGH LEVEL WARNING DEVICE (FLAGTREE)
- ⚡ FLAGGER
- TANSAT TOW AWAY NO STOPPING ANY TIME
- ◻ EXISTING DRIVEWAY
- ▨ WORK ZONE (ACTIVITY AREA) LIMITS
- DIRECTION OF TRAFFIC (NOT PAVEMENT MARKING)

CALL 811 BEFORE YOU DIG.
 WISCONSIN TOLL FREE
 800-242-8511

BRIGHTSPEED

PLANS PREPARED BY:
CHC
 A CONGRUEX COMPANY
 9095 Rio San Diego Dr. Ste 165
 San Diego, CA 92108-1694
 (949) 250-0004 / FAX (949) 250-0006

REVISIONS

REV.	DESCRIPTION	BY	DATE
0	INITIAL DESIGN	V.D.	2/20/24

BRIGHTSPEED
 CONFIDENTIAL AND PROPRIETARY
 LCRSWIXC

TC-11 OF TC-44

SCALE: 1:50

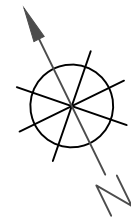

624 7TH ST. N
 7TH ST. N & VINE ST.
 MH #19 ACCESS
 WORK AREA 12 OF 44

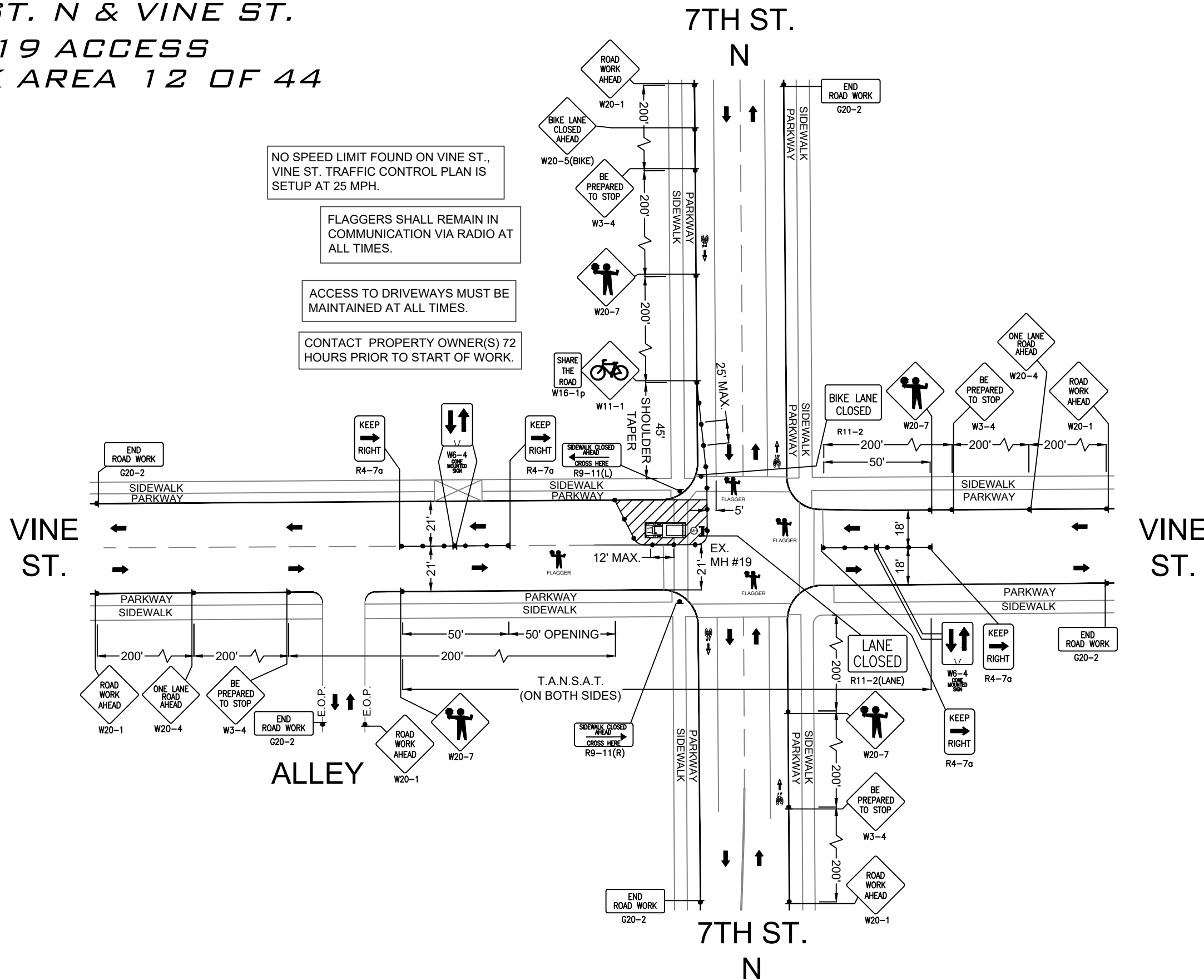

NO SPEED LIMIT FOUND ON VINE ST.,
 VINE ST. TRAFFIC CONTROL PLAN IS
 SETUP AT 25 MPH.

FLAGGERS SHALL REMAIN IN
 COMMUNICATION VIA RADIO AT
 ALL TIMES.

ACCESS TO DRIVEWAYS MUST BE
 MAINTAINED AT ALL TIMES.

CONTACT PROPERTY OWNER(S) 72
 HOURS PRIOR TO START OF WORK.

- LEGEND**
- * PORTABLE FLASHING BEACON (P.F.B.)
 - ≡ TYPE III BARRICADE W/SIGN
 - ≡ TYPE II BARRICADE W/SIGN
 - CHANNELIZING DEVICE
 - ▼ TRAFFIC CONE WITH CLIP ON SIGN
 - TYPE I W/ SIGN
 - EXISTING SIGN
 - ⊙ SIGNALIZED INTERSECTION
 - ⚡ FLASHING ARROW BOARD
 - ⚡ HIGH LEVEL WARNING DEVICE (FLAGTREE)
 - ♠ FLAGGER
 - TANSAT TOW AWAY NO STOPPING ANY TIME
 - ▭ EXISTING DRIVEWAY
 - ▨ WORK ZONE (ACTIVITY AREA) LIMITS
 - DIRECTION OF TRAFFIC (NOT PAVEMENT MARKING)

CALL 811 BEFORE YOU DIG.
 WISCONSIN TOLL FREE
 800-242-8511

BRIGHTSPEED

PLANS PREPARED BY:
CHC
 A CONGRUEX COMPANY
 9095 Rio San Diego Dr. Ste 165
 San Diego, CA 92108-1694
 (949) 250-0004 / FAX (949) 250-0006

REVISIONS

REV.	DESCRIPTION	BY	DATE
0	INITIAL DESIGN	V.D.	2/20/24

BRIGHTSPEED
 CONFIDENTIAL AND PROPRIETARY
 LCRSWIXC

TC-12 OF TC-44

SCALE: 1:50

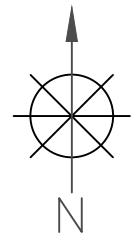

129 STATE ST.
 STATE ST. & 2ND ST. N
 MH #12 ACCESS
 WORK AREA 13 OF 44

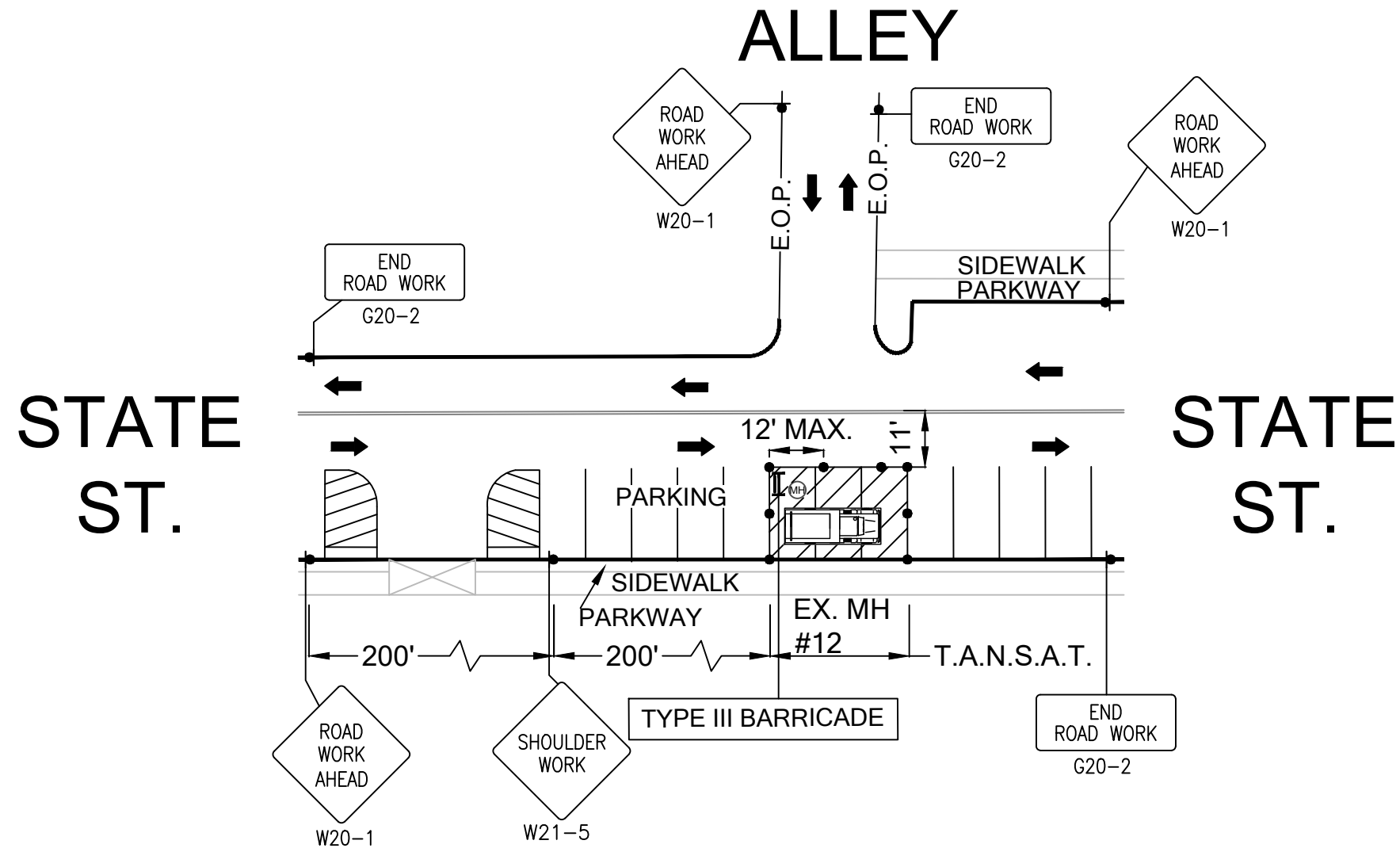

MANHOLE #12 IS +/- 210' N/W
 OF THE C/L OF 2ND ST. N.

ACCESS TO DRIVEWAYS MUST BE
 MAINTAINED AT ALL TIMES.

CONTACT PROPERTY OWNER(S) 72
 HOURS PRIOR TO START OF WORK.

NO SPEED LIMIT FOUND ON STATE ST.,
 STATE ST. TRAFFIC CONTROL PLAN IS
 SETUP AT 25 MPH.

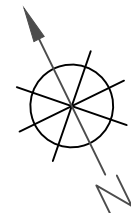

LEGEND

- * PORTABLE FLASHING BEACON (P.F.B.)
- ≡ TYPE III BARRICADE W/SIGN
- ≡ TYPE II BARRICADE W/SIGN
- CHANNELIZING DEVICE
- ▼ TRAFFIC CONE WITH CLIP ON SIGN
- TYPE I W/ SIGN
- EXISTING SIGN
- ⊙ SIGNALIZED INTERSECTION
- ⚡ FLASHING ARROW BOARD
- ⚡ HIGH LEVEL WARNING DEVICE (FLAGTREE)
- ⚡ FLAGGER
- TANSAT TOW AWAY NO STOPPING ANY TIME
- ⊠ EXISTING DRIVEWAY
- ▨ WORK ZONE (ACTIVITY AREA) LIMITS
- DIRECTION OF TRAFFIC (NOT PAVEMENT MARKING)

CALL 811 BEFORE YOU DIG.
 WISCONSIN TOLL FREE
 800-242-8511

BRIGHTSPEED

PLANS PREPARED BY:
CHC
 A CONGRUEX COMPANY
 9095 Rio San Diego Dr. Ste 165
 San Diego, CA 92108-1694
 (949) 250-0004 / FAX (949) 250-0006

REVISIONS			
REV.	DESCRIPTION	BY	DATE
0	INITIAL DESIGN	V.D.	2/20/24

BRIGHTSPEED
 CONFIDENTIAL AND PROPRIETARY
 LCRSWIXC

TC-13 OF TC-44

SCALE: 1:30

**225 STATE ST.
STATE ST. & 2ND ST. N
MH #06 ACCESS
WORK AREA 14 OF 44**

STATE ST.

STATE ST.

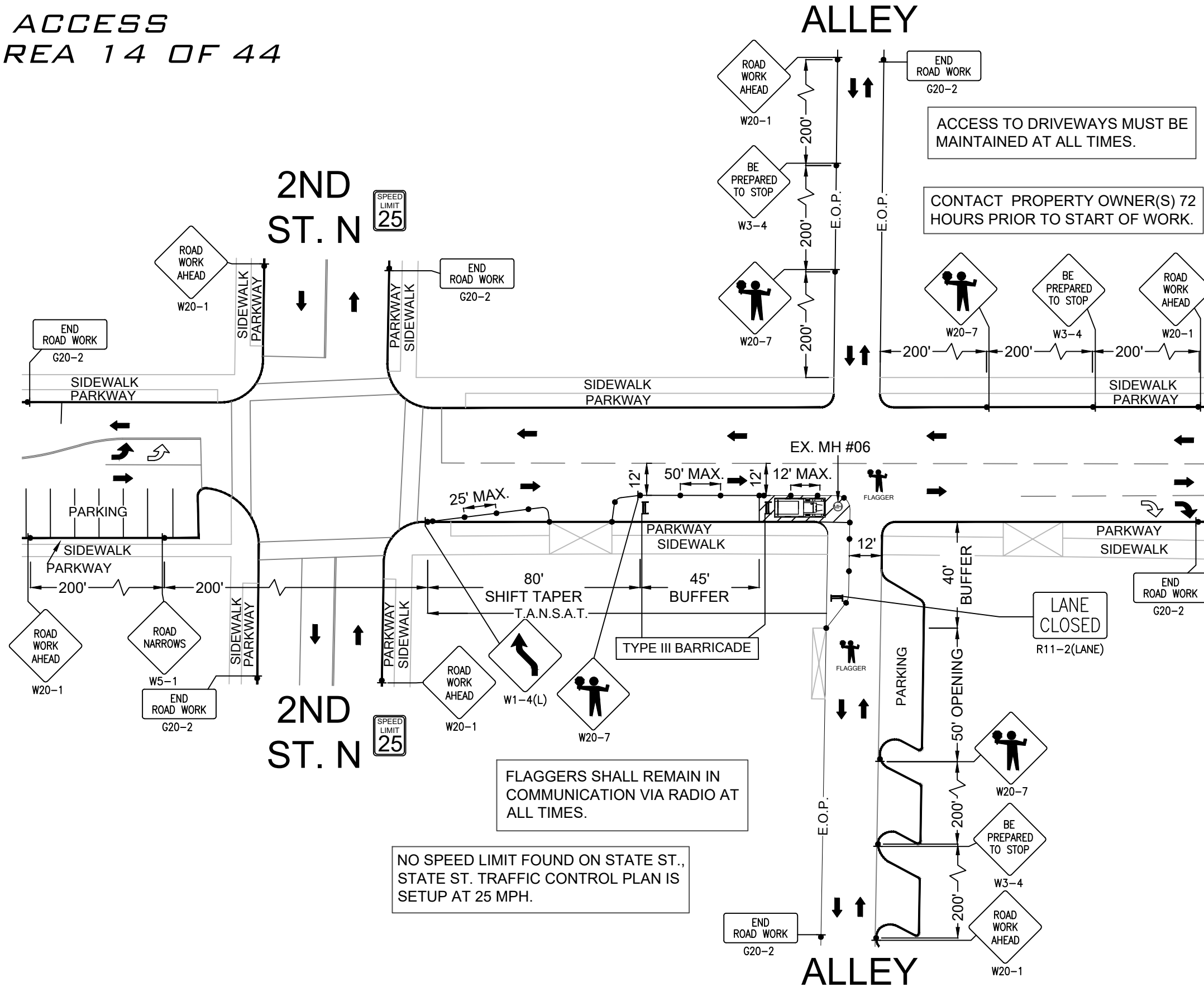

FLAGGERS SHALL REMAIN IN COMMUNICATION VIA RADIO AT ALL TIMES.

NO SPEED LIMIT FOUND ON STATE ST., STATE ST. TRAFFIC CONTROL PLAN IS SETUP AT 25 MPH.

ACCESS TO DRIVEWAYS MUST BE MAINTAINED AT ALL TIMES.

CONTACT PROPERTY OWNER(S) 72 HOURS PRIOR TO START OF WORK.

LEGEND

- * PORTABLE FLASHING BEACON (P.F.B.)
- ≡ TYPE III BARRICADE W/SIGN
- ≡ TYPE II BARRICADE W/SIGN
- CHANNELIZING DEVICE
- ⚡ TRAFFIC CONE WITH CLIP ON SIGN
- ▬ TYPE I W/ SIGN
- ▭ EXISTING SIGN
- ⊙ SIGNALIZED INTERSECTION
- ⚡ FLASHING ARROW BOARD
- ⚡ HIGH LEVEL WARNING DEVICE (FLAGTREE)
- ⚡ FLAGGER
- TANSAT TOW AWAY NO STOPPING ANY TIME
- ▭ EXISTING DRIVEWAY
- ▨ WORK ZONE (ACTIVITY AREA) LIMITS
- DIRECTION OF TRAFFIC (NOT PAVEMENT MARKING)

CALL 811 BEFORE YOU DIG.
WISCONSIN TOLL FREE
800-242-8511

BRIGHTSPEED

PLANS PREPARED BY:
XCHC
A CONGRUEX COMPANY
9095 Rio San Diego Dr. Ste 165
San Diego, CA 92108-1694
(949) 250-0004 / FAX (949) 250-0006

REVISIONS			
REV.	DESCRIPTION	BY	DATE
0	INITIAL DESIGN	V.D.	2/20/24

BRIGHTSPEED
CONFIDENTIAL AND PROPRIETARY
LCRSWIXC

TC-14 OF TC-44

SCALE: 1:40

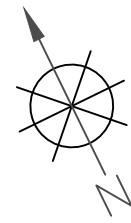

312 STATE ST.
 STATE ST. & 3RD ST. N (I-90 ALT.-US-53)
 MH #05 ACCESS
 WORK AREA 15 OF 44

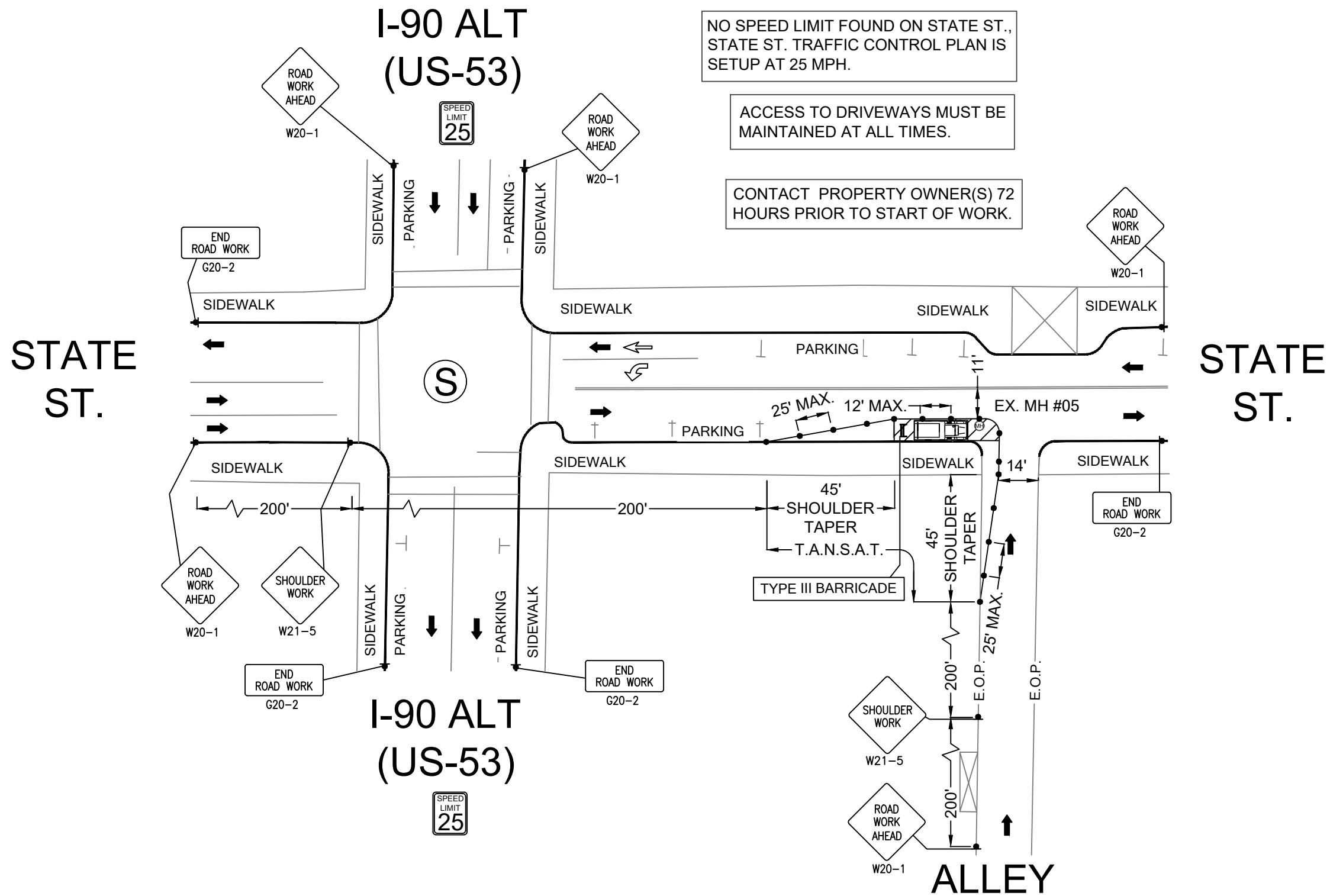

NO SPEED LIMIT FOUND ON STATE ST.,
 STATE ST. TRAFFIC CONTROL PLAN IS
 SETUP AT 25 MPH.

ACCESS TO DRIVEWAYS MUST BE
 MAINTAINED AT ALL TIMES.

CONTACT PROPERTY OWNER(S) 72
 HOURS PRIOR TO START OF WORK.

LEGEND

- * PORTABLE FLASHING BEACON (P.F.B.)
- ≡ TYPE III BARRICADE W/SIGN
- ≡ TYPE II BARRICADE W/SIGN
- CHANNELIZING DEVICE
- ▼ TRAFFIC CONE WITH CLIP ON SIGN
- TYPE I W/ SIGN
- EXISTING SIGN
- Ⓢ SIGNALIZED INTERSECTION
- ⚡ FLASHING ARROW BOARD
- ⚡ HIGH LEVEL WARNING DEVICE (FLAGTREE)
- ⚡ FLAGGER
- TANSAT TOW AWAY NO STOPPING ANY TIME
- ⊠ EXISTING DRIVEWAY
- ▨ WORK ZONE (ACTIVITY AREA) LIMITS
- DIRECTION OF TRAFFIC (NOT PAVEMENT MARKING)

CALL 811 BEFORE YOU DIG.
 WISCONSIN TOLL FREE
 800-242-8511

BRIGHTSPEED

PLANS PREPARED BY:
XCHC
 A CONGRUEX COMPANY
 9095 Rio San Diego Dr. Ste 165
 San Diego, CA 92108-1694
 (949) 250-0004 / FAX (949) 250-0006

REVISIONS

REV.	DESCRIPTION	BY	DATE
0	INITIAL DESIGN	V.D.	2/20/24

BRIGHTSPEED
 CONFIDENTIAL AND PROPRIETARY
 LCRSWIXC

TC-15 OF TC-44

SCALE: 1:40

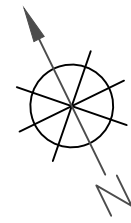

**602 STATE ST.
STATE ST. & 6TH ST. N
MH #37 ACCESS
WORK AREA 16 OF 44**

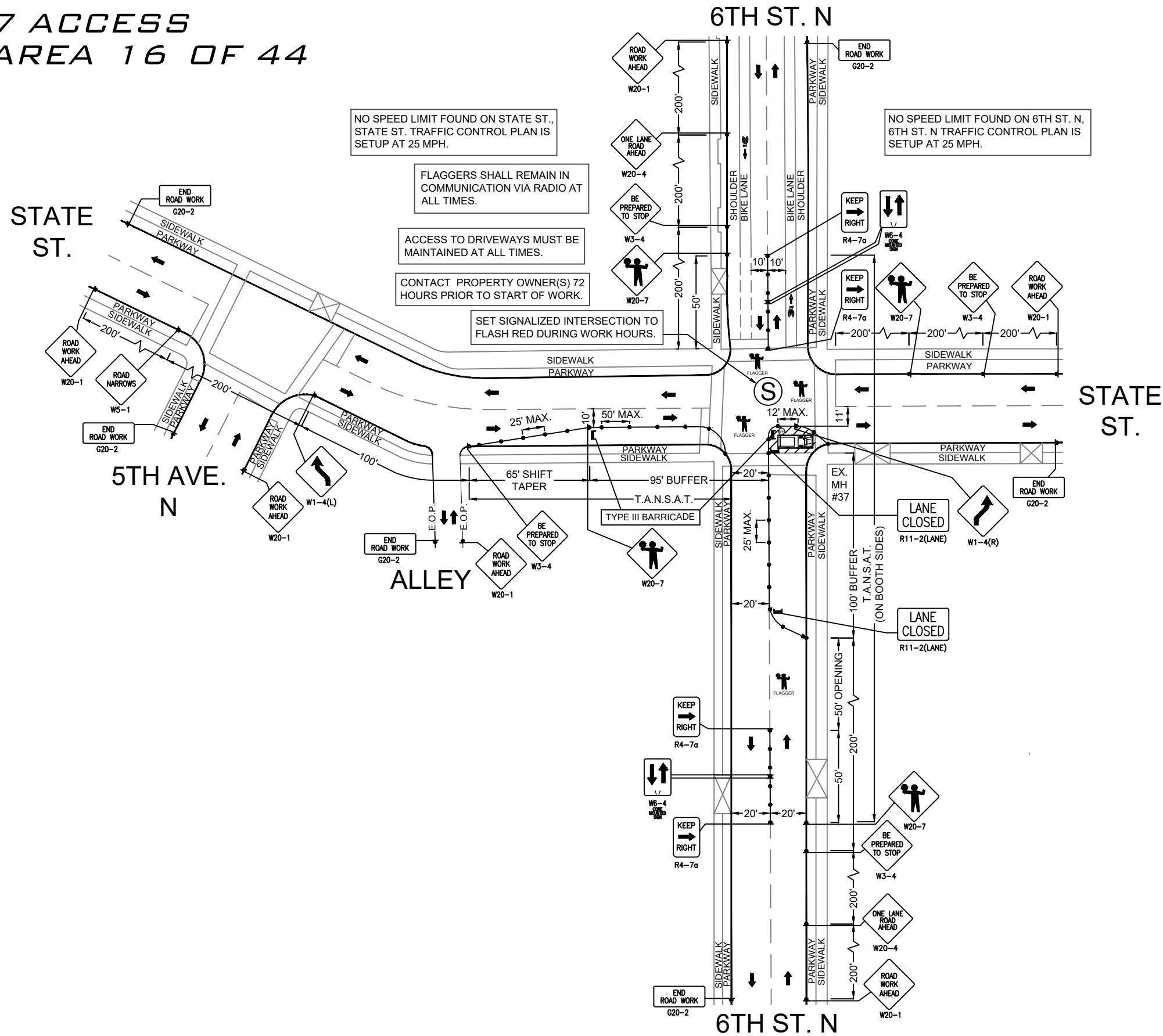

LEGEND

- * PORTABLE FLASHING BEACON (P.F.B.)
- ≡ TYPE III BARRICADE W/SIGN
- ≡ TYPE II BARRICADE W/SIGN
- CHANNELIZING DEVICE
- ⬇ TRAFFIC CONE WITH CLIP ON SIGN
- ▬ TYPE I W/ SIGN
- EXISTING SIGN
- ⊙ SIGNALIZED INTERSECTION
- ⚡ FLASHING ARROW BOARD
- ⚡ HIGH LEVEL WARNING DEVICE (FLAGTREE)
- ⚡ FLAGGER
- TANSAT TOW AWAY NO STOPPING ANY TIME
- ⊠ EXISTING DRIVEWAY
- ▨ WORK ZONE (ACTIVITY AREA) LIMITS
- ➔ DIRECTION OF TRAFFIC (NOT PAVEMENT MARKING)

CALL 811 BEFORE YOU DIG.
WISCONSIN TOLL FREE
800-242-8511

BRIGHTSPEED

PLANS PREPARED BY:
XCHC
A CONGRUEX COMPANY
9095 Rio San Diego Dr. Ste 165
San Diego, CA 92108-1694
(949) 250-0004 / FAX (949) 250-0006

REVISIONS			
REV.	DESCRIPTION	BY	DATE
0	INITIAL DESIGN	V.D.	2/20/24

BRIGHTSPEED
CONFIDENTIAL AND PROPRIETARY
LCRSWIXC

TC-16 OF TC-44

SCALE: 1:60

602 STATE ST.
 STATE ST. & 6TH ST. N
 MH #38 ACCESS
 WORK AREA 17 OF 44

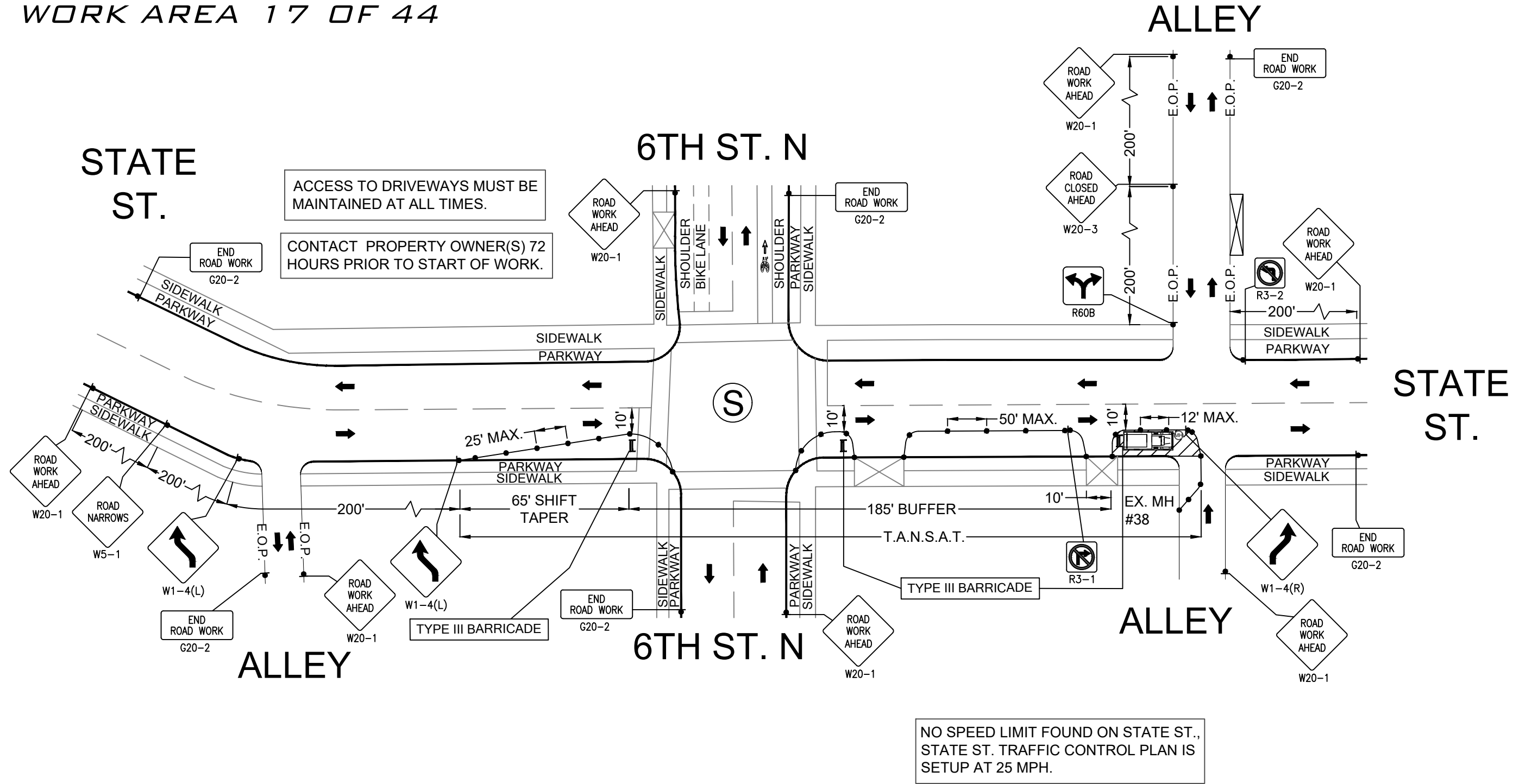

ACCESS TO DRIVEWAYS MUST BE MAINTAINED AT ALL TIMES.
 CONTACT PROPERTY OWNER(S) 72 HOURS PRIOR TO START OF WORK.

NO SPEED LIMIT FOUND ON STATE ST.,
 STATE ST. TRAFFIC CONTROL PLAN IS
 SETUP AT 25 MPH.

LEGEND

- * PORTABLE FLASHING BEACON (P.F.B.)
- ▤ TYPE III BARRICADE W/SIGN
- ▤ TYPE II BARRICADE W/SIGN
- CHANNELIZING DEVICE
- ▼ TRAFFIC CONE WITH CLIP ON SIGN
- ▤ TYPE I W/ SIGN
- ▤ EXISTING SIGN
- Ⓢ SIGNALIZED INTERSECTION
- ⚡ FLASHING ARROW BOARD
- ⚡ HIGH LEVEL WARNING DEVICE (FLAGTREE)
- ⚡ FLAGGER
- TANSAT TOW AWAY NO STOPPING ANY TIME
- ▤ EXISTING DRIVEWAY
- ▤ WORK ZONE (ACTIVITY AREA) LIMITS
- DIRECTION OF TRAFFIC (NOT PAVEMENT MARKING)

CALL 811 BEFORE YOU DIG.
 WISCONSIN TOLL FREE
 800-242-8511

BRIGHTSPEED

PLANS PREPARED BY:
CHC
 A CONGRUEX COMPANY
 9095 Rio San Diego Dr. Ste 165
 San Diego, CA 92108-1694
 (949) 250-0004 / FAX (949) 250-0006

REVISIONS

REV.	DESCRIPTION	BY	DATE
0	INITIAL DESIGN	V.D.	2/20/24

BRIGHTSPEED
 CONFIDENTIAL AND PROPRIETARY
 LCRSWIXC

TC-17 OF TC-44

SCALE: 1:40

**630 STATE ST.
STATE ST. & 7TH ST. N
MH #39 ACCESS
WORK AREA 18 OF 44**

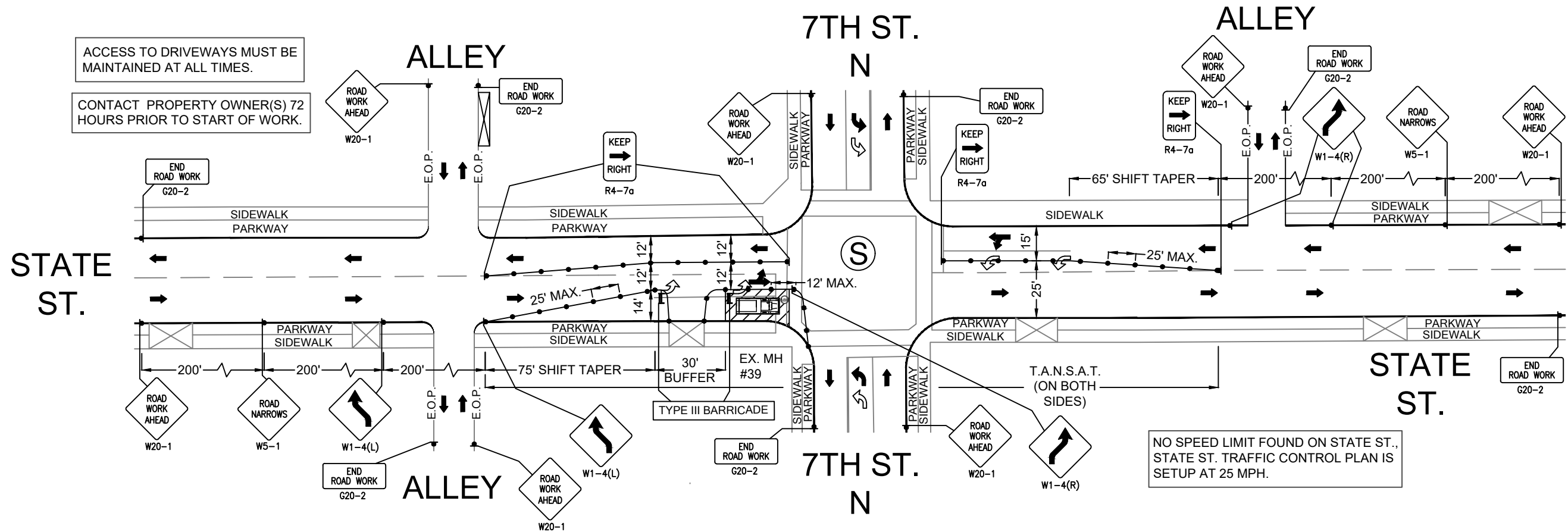

ACCESS TO DRIVEWAYS MUST BE MAINTAINED AT ALL TIMES.
CONTACT PROPERTY OWNER(S) 72 HOURS PRIOR TO START OF WORK.

NO SPEED LIMIT FOUND ON STATE ST., STATE ST. TRAFFIC CONTROL PLAN IS SETUP AT 25 MPH.

LEGEND

- * PORTABLE FLASHING BEACON (P.F.B.)
- ≡ TYPE III BARRICADE W/SIGN
- ≡ TYPE II BARRICADE W/SIGN
- CHANNELIZING DEVICE
- ▼ TRAFFIC CONE WITH CLIP ON SIGN
- TYPE I W/ SIGN
- EXISTING SIGN
- ⊙ SIGNALIZED INTERSECTION
- ▬ FLASHING ARROW BOARD
- ⚡ HIGH LEVEL WARNING DEVICE (FLAGTREE)
- ♠ FLAGGER
- TANSAT TOW AWAY NO STOPPING ANY TIME
- ⊠ EXISTING DRIVEWAY
- ▨ WORK ZONE (ACTIVITY AREA) LIMITS
- DIRECTION OF TRAFFIC (NOT PAVEMENT MARKING)

CALL 811 BEFORE YOU DIG.
WISCONSIN TOLL FREE
800-242-8511

BRIGHTSPEED

PLANS PREPARED BY:
CHC
A CONGRUEX COMPANY
9095 Rio San Diego Dr. Ste 165
San Diego, CA 92108-1694
(949) 250-0004 / FAX (949) 250-0006

REVISIONS

REV.	DESCRIPTION	BY	DATE
0	INITIAL DESIGN	V.D.	2/20/24

BRIGHTSPEED
CONFIDENTIAL AND PROPRIETARY
LCRSWIXC

TC-18 OF TC-44

SCALE: 1:50

**711 STATE ST.
STATE ST. & 7TH ST. N
MH #43 ACCESS
WORK AREA 19 OF 44**

PEDESTRIAN CONTROL NOTES:

A DEDICATED INDIVIDUAL WILL BE ASSIGNED THE RESPONSIBILITY OF ESCORTING PEDESTRIANS THROUGH THE WORK AREA IN ACCORDANCE WITH THREE MAJOR CONSIDERATIONS:

1. PEDESTRIANS SHOULD NOT BE LED INTO DIRECT CONFLICT WITH WORK SITE VEHICLES, EQUIPMENT OR OPERATIONS
2. PEDESTRIANS SHOULD NOT BE LED INTO DIRECT CONFLICT WITH MAINLINE TRAFFIC MOVING THROUGH OR AROUND THE WORK SITE.
3. PEDESTRIANS SHOULD BE PROVIDED WITH A REASONABLY SAFE, CONVENIENT AND ACCESSIBLE PATH THAT REPLICATES AS NEARLY AS PRACTICAL THE MOST DESIRABLE CHARACTERISTICS OF THE EXISTING SIDEWALK OR FOOTPATH

FLAGGER TO ASSIST PEDESTRIANS THROUGH WORK AREA (SEE PED NOTES)

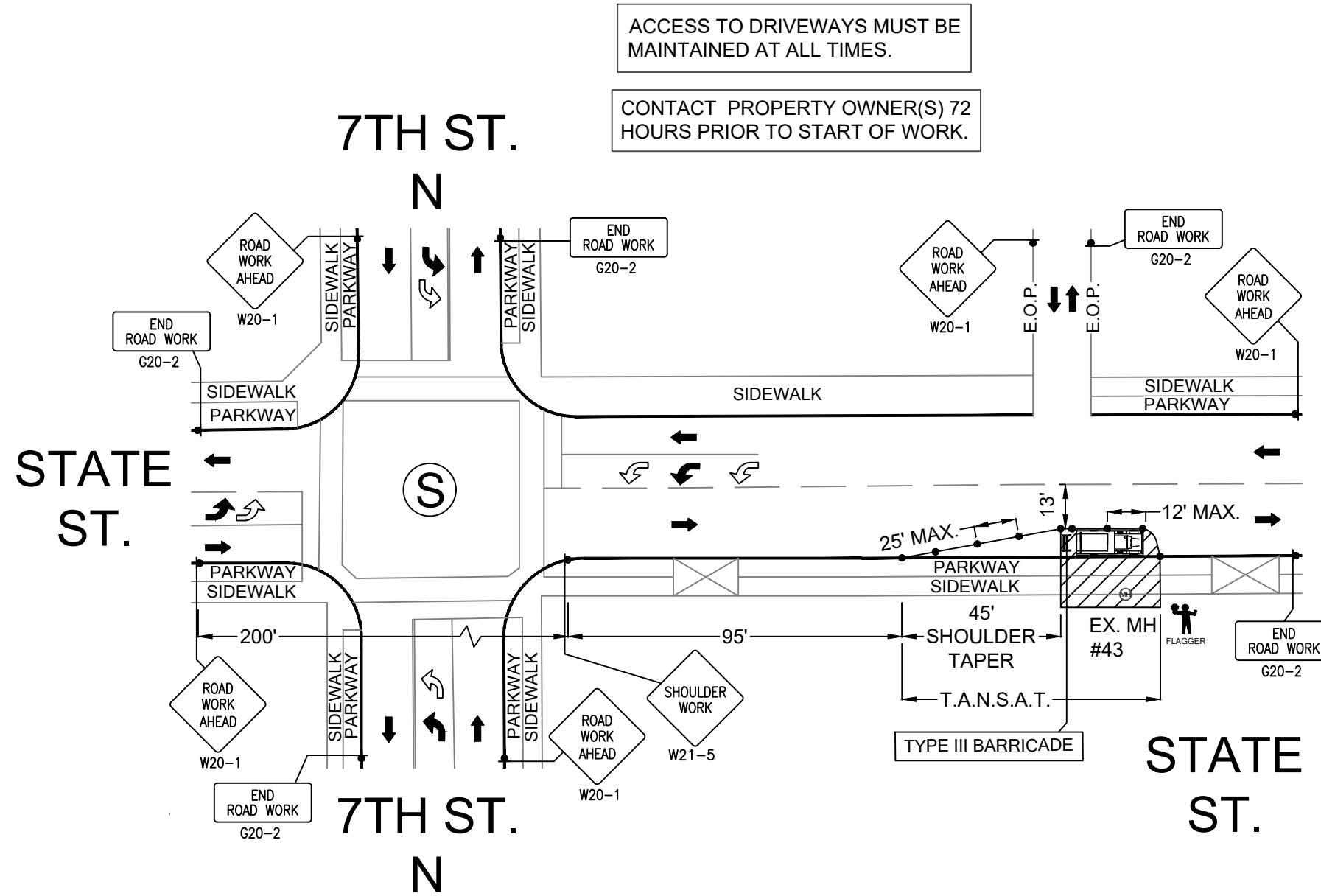

LEGEND

- * PORTABLE FLASHING BEACON (P.F.B.)
- ≡ TYPE III BARRICADE W/SIGN
- ≡ TYPE II BARRICADE W/SIGN
- CHANNELIZING DEVICE
- ▼ TRAFFIC CONE WITH CLIP ON SIGN
- TYPE I W/ SIGN
- EXISTING SIGN
- ⊙ SIGNALIZED INTERSECTION
- ⊞ FLASHING ARROW BOARD
- ⚡ HIGH LEVEL WARNING DEVICE (FLAGTREE)
- ♠ FLAGGER
- TANSAT TOW AWAY NO STOPPING ANY TIME
- ⊞ EXISTING DRIVEWAY
- ▨ WORK ZONE (ACTIVITY AREA) LIMITS
- DIRECTION OF TRAFFIC (NOT PAVEMENT MARKING)

CALL 811 BEFORE YOU DIG.
WISCONSIN TOLL FREE
800-242-8511

BRIGHTSPEED

PLANS PREPARED BY:
CHC
A CONGRUEX COMPANY
9095 Rio San Diego Dr. Ste 165
San Diego, CA 92108-1694
(949) 250-0004 / FAX (949) 250-0006

REVISIONS

REV.	DESCRIPTION	BY	DATE
0	INITIAL DESIGN	V.D.	2/20/24

BRIGHTSPEED
CONFIDENTIAL AND PROPRIETARY
LCRSWIXC

TC-19 OF TC-44

SCALE: 1:40

**228 MAIN ST.
MAIN ST. & 2ND ST. N
MH #08 ACCESS
WORK AREA 20 OF 44**

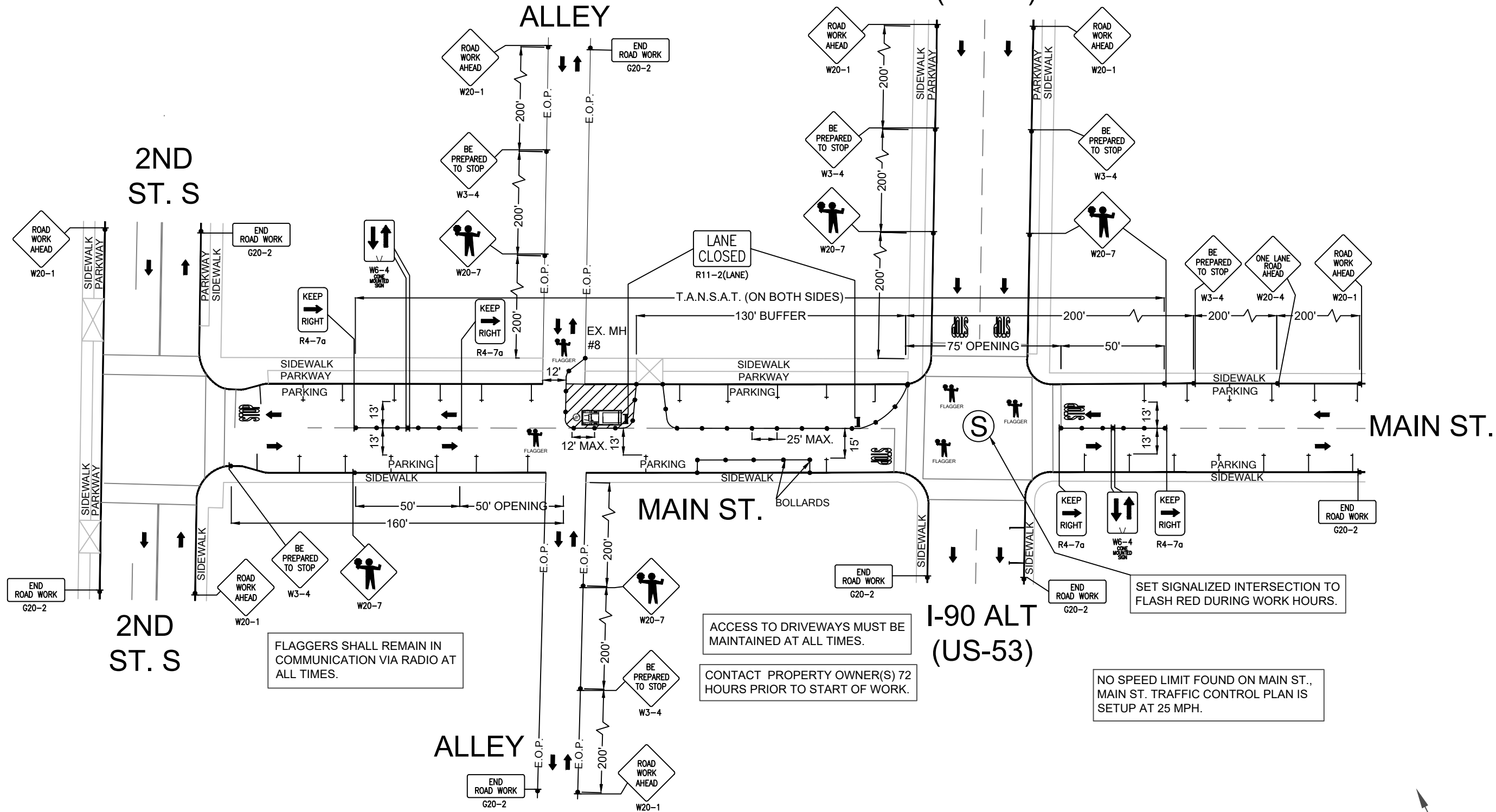

LEGEND

- * PORTABLE FLASHING BEACON (P.F.B.)
- ≡ TYPE III BARRICADE W/SIGN
- ≡ TYPE II BARRICADE W/SIGN
- CHANNELIZING DEVICE
- ▼ TRAFFIC CONE WITH CLIP ON SIGN
- TYPE I W/ SIGN
- EXISTING SIGN
- ⊙ SIGNALIZED INTERSECTION
- ⚡ FLASHING ARROW BOARD
- ⚡ HIGH LEVEL WARNING DEVICE (FLAGTREE)
- ♠ FLAGGER
- TANSAT TOW AWAY NO STOPPING ANY TIME
- ⊠ EXISTING DRIVEWAY
- ▨ WORK ZONE (ACTIVITY AREA) LIMITS
- DIRECTION OF TRAFFIC (NOT PAVEMENT MARKING)

CALL 811 BEFORE YOU DIG.
WISCONSIN TOLL FREE
800-242-8511

BRIGHTSPEED

PLANS PREPARED BY:
CHC
A CONGRUEX COMPANY
9095 Rio San Diego Dr. Ste 165
San Diego, CA 92108-1694
(949) 250-0004 / FAX (949) 250-0006

REVISIONS			
REV.	DESCRIPTION	BY	DATE
0	INITIAL DESIGN	V.D.	2/20/24

BRIGHTSPEED
CONFIDENTIAL AND PROPRIETARY
LCRSWIXC

TC-20 OF TC-44

SCALE: 1:50

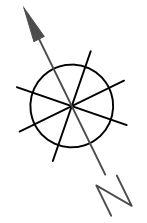

**325 MAIN ST.
 MAIN ST. & 3RD ST. N (I-90 ALT.-US-53)
 MH #28 ACCESS
 WORK AREA 21 OF 44**

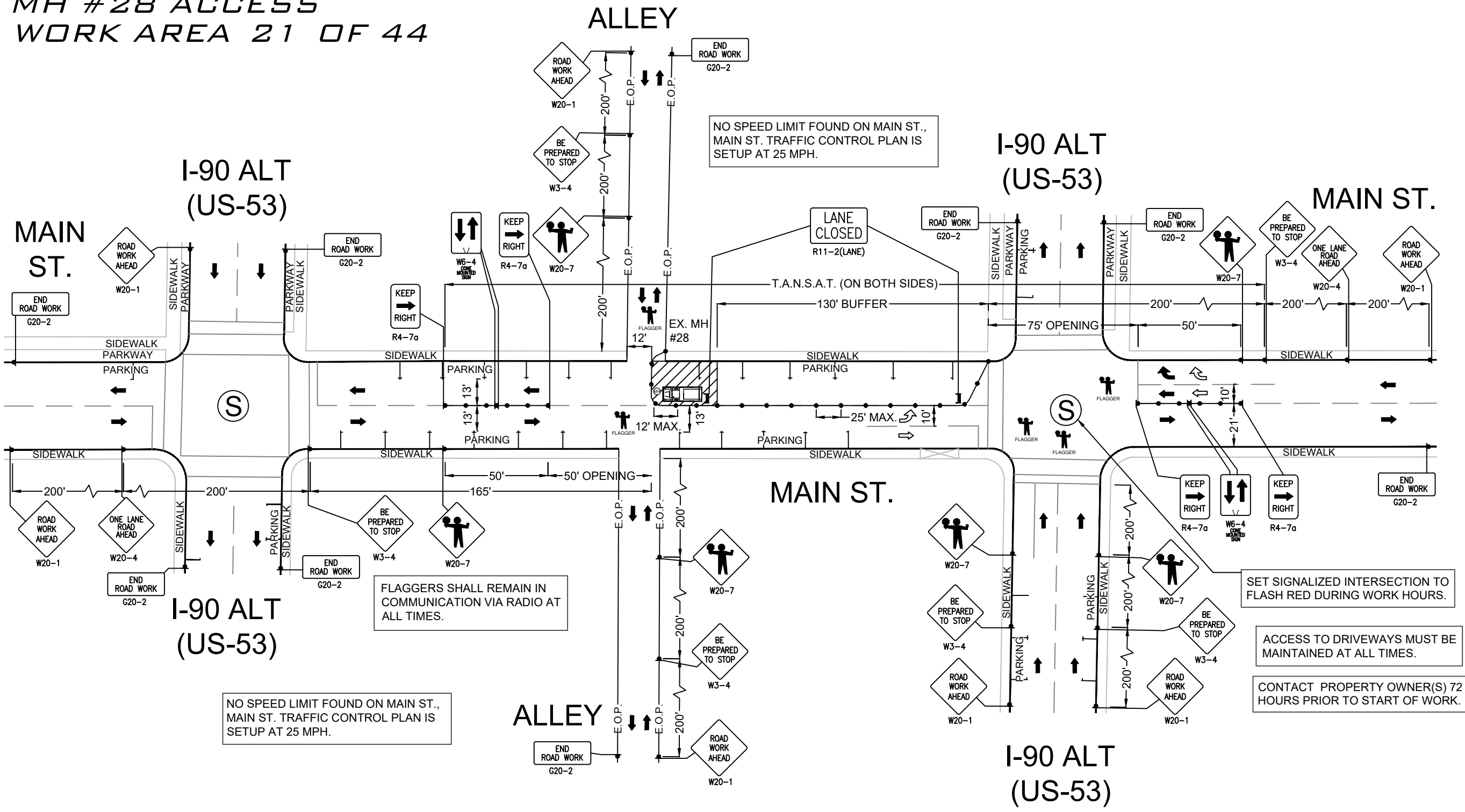

LEGEND

- * PORTABLE FLASHING BEACON (P.F.B.)
- ≡ TYPE III BARRICADE W/SIGN
- ≡ TYPE II BARRICADE W/SIGN
- CHANNELIZING DEVICE
- ▼ TRAFFIC CONE WITH CLIP ON SIGN
- TYPE I W/ SIGN
- EXISTING SIGN
- Ⓢ SIGNALIZED INTERSECTION
- ⚡ FLASHING ARROW BOARD
- ⚡ HIGH LEVEL WARNING DEVICE (FLAGTREE)
- ♠ FLAGGER
- TANSAT TOW AWAY NO STOPPING ANY TIME
- ▭ EXISTING DRIVEWAY
- ▨ WORK ZONE (ACTIVITY AREA) LIMITS
- DIRECTION OF TRAFFIC (NOT PAVEMENT MARKING)

CALL 811 BEFORE YOU DIG.
 WISCONSIN TOLL FREE
 800-242-8511

BRIGHTSPEED

PLANS PREPARED BY:
CHC
 A CONGRUEX COMPANY
 9095 Rio San Diego Dr. Ste 165
 San Diego, CA 92108-1694
 (949) 250-0004 / FAX (949) 250-0006

REVISIONS			
REV.	DESCRIPTION	BY	DATE
0	INITIAL DESIGN	V.D.	2/20/24

BRIGHTSPEED
 CONFIDENTIAL AND PROPRIETARY
 LCRSWIXC

TC-21 OF TC-44

SCALE: 1:50

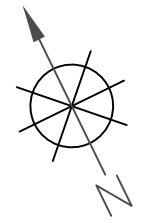

419 MAIN ST.
 MAIN ST. & 5TH AVE. N)
 MH #29 ACCESS
 WORK AREA 22 OF 44

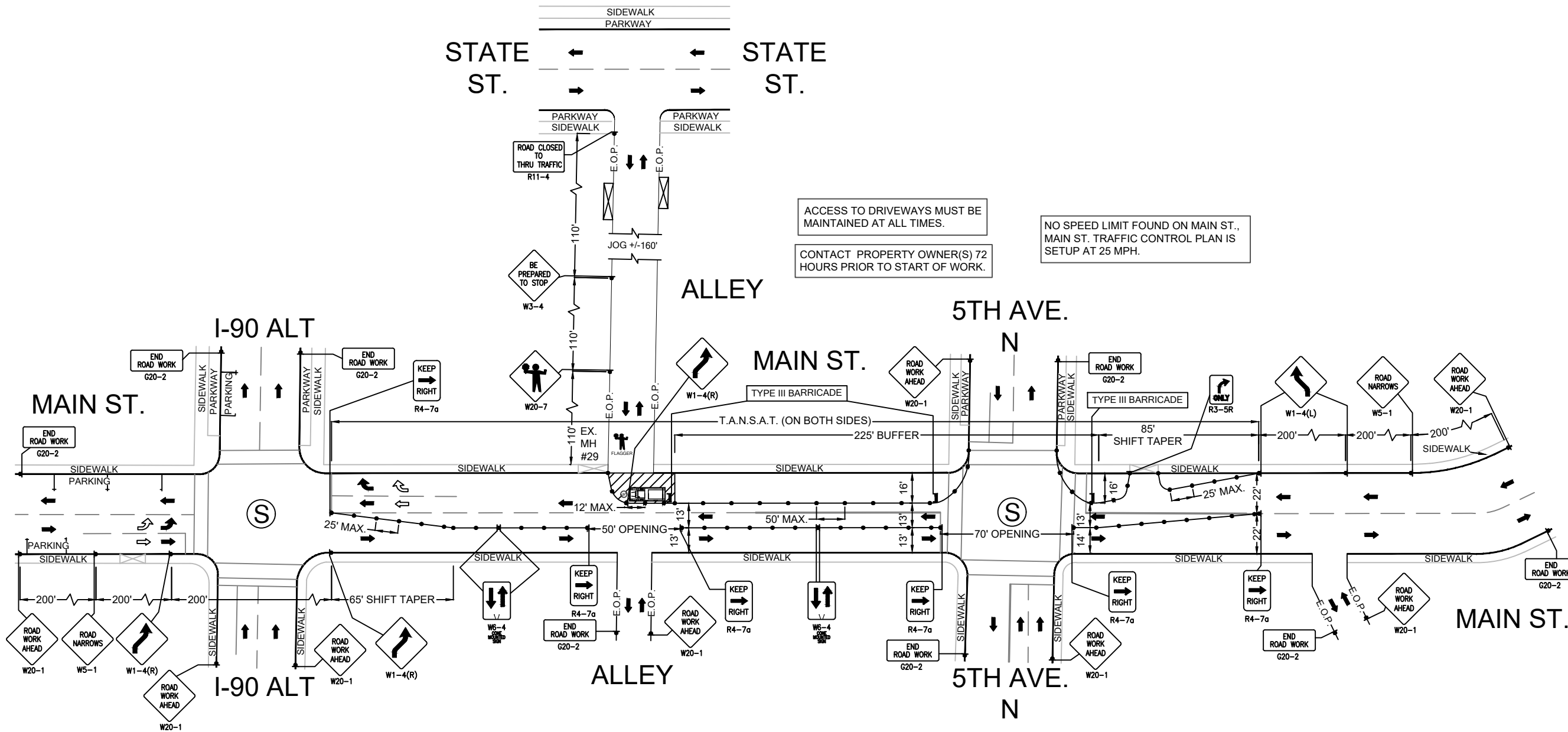

LEGEND

- * PORTABLE FLASHING BEACON (P.F.B.)
- ≡ TYPE III BARRICADE W/SIGN
- ≡ TYPE II BARRICADE W/SIGN
- CHANNELIZING DEVICE
- ▼ TRAFFIC CONE WITH CLIP ON SIGN
- TYPE I W/ SIGN
- EXISTING SIGN
- ⊙ SIGNALIZED INTERSECTION
- ⚡ FLASHING ARROW BOARD
- ⚡ HIGH LEVEL WARNING DEVICE (FLAGTREE)
- ⚡ FLAGGER
- TANSAT TOW AWAY NO STOPPING ANY TIME
- ⊞ EXISTING DRIVEWAY
- ▨ WORK ZONE (ACTIVITY AREA) LIMITS
- DIRECTION OF TRAFFIC (NOT PAVEMENT MARKING)

CALL 811 BEFORE YOU DIG.
 WISCONSIN TOLL FREE
 800-242-8511

BRIGHTSPEED

PLANS PREPARED BY:
CHC
 A CONGRUEUX COMPANY
 9095 Rio San Diego Dr. Ste 165
 San Diego, CA 92108-1694
 (949) 250-0004 / FAX (949) 250-0006

REVISIONS			
REV.	DESCRIPTION	BY	DATE
0	INITIAL DESIGN	V.D.	2/20/24

BRIGHTSPEED
 CONFIDENTIAL AND PROPRIETARY
 LCRSWIXC

TC-22 OF TC-44

SCALE: 1:60

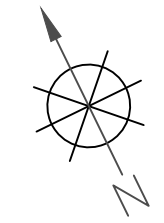

517 MAIN ST.
 MAIN ST. & 6TH AVE. N)
 MH #31 ACCESS
 WORK AREA 23 OF 44

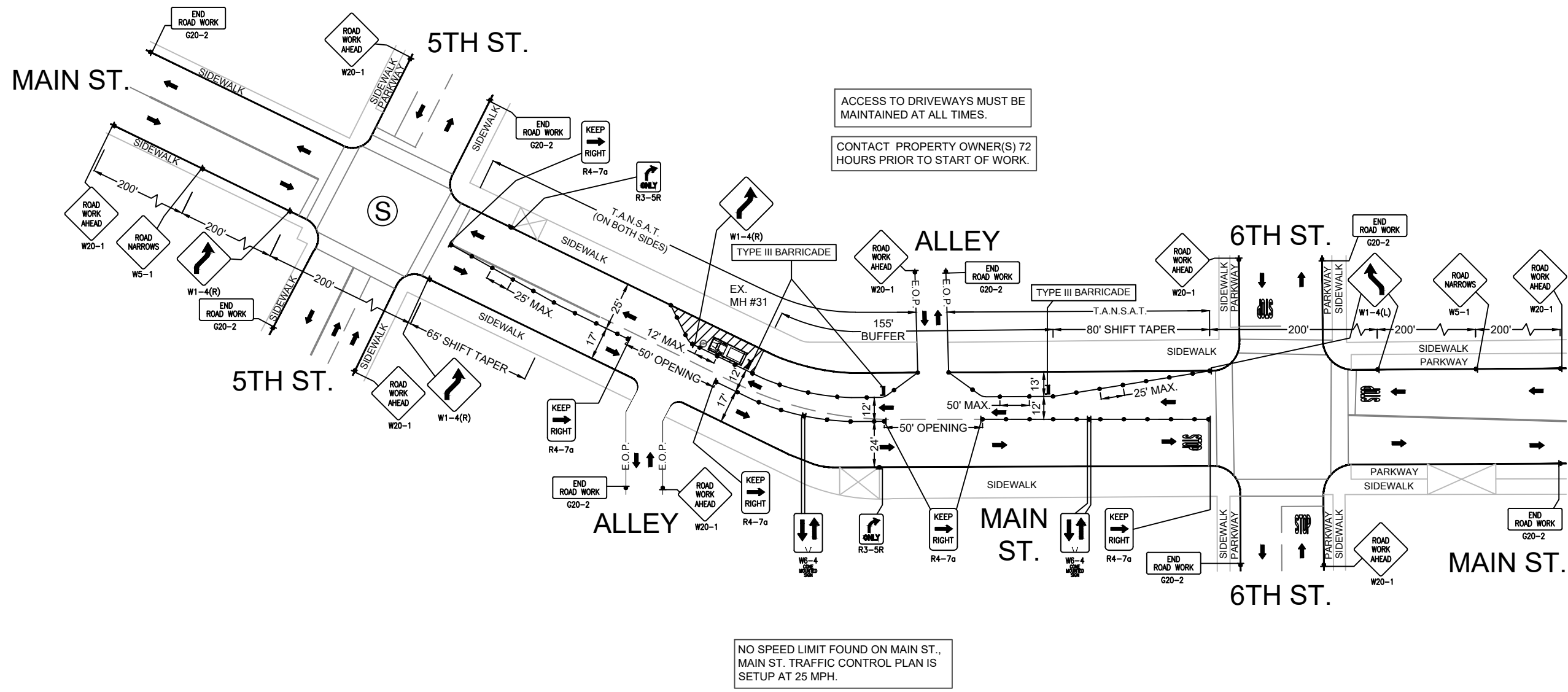

LEGEND 3

- * PORTABLE FLASHING BEACON (P.F.B.)
- ≡ TYPE III BARRICADE W/SIGN
- ≡ TYPE II BARRICADE W/SIGN
- CHANNELIZING DEVICE
- ▼ TRAFFIC CONE WITH CLIP ON SIGN
- ▬ TYPE I W/ SIGN
- EXISTING SIGN
- ⊙ SIGNALIZED INTERSECTION
- ⊞ FLASHING ARROW BOARD
- ⚡ HIGH LEVEL WARNING DEVICE (FLAGTREE)
- ⚠ FLAGGER
- TANSAT TOW AWAY NO STOPPING ANY TIME
- ⊞ EXISTING DRIVEWAY
- ▨ WORK ZONE (ACTIVITY AREA) LIMITS
- DIRECTION OF TRAFFIC (NOT PAVEMENT MARKING)

CALL 811 BEFORE YOU DIG.
 WISCONSIN TOLL FREE
 800-242-8511

BRIGHTSPEED

PLANS PREPARED BY:
CHC
 A CONGRUEX COMPANY
 9095 Rio San Diego Dr. Ste 165
 San Diego, CA 92108-1694
 (949) 250-0004 / FAX (949) 250-0006

REVISIONS			
REV.	DESCRIPTION	BY	DATE
0	INITIAL DESIGN	V.D.	2/20/24

BRIGHTSPEED
 CONFIDENTIAL AND PROPRIETARY
 LCRSWIXC

TC-23 OF TC-44

SCALE: 1:60

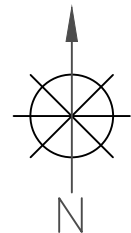

530 MAIN ST.
 MAIN ST. & 6TH AVE. N)
 MH #33 ACCESS
 WORK AREA 24 OF 44

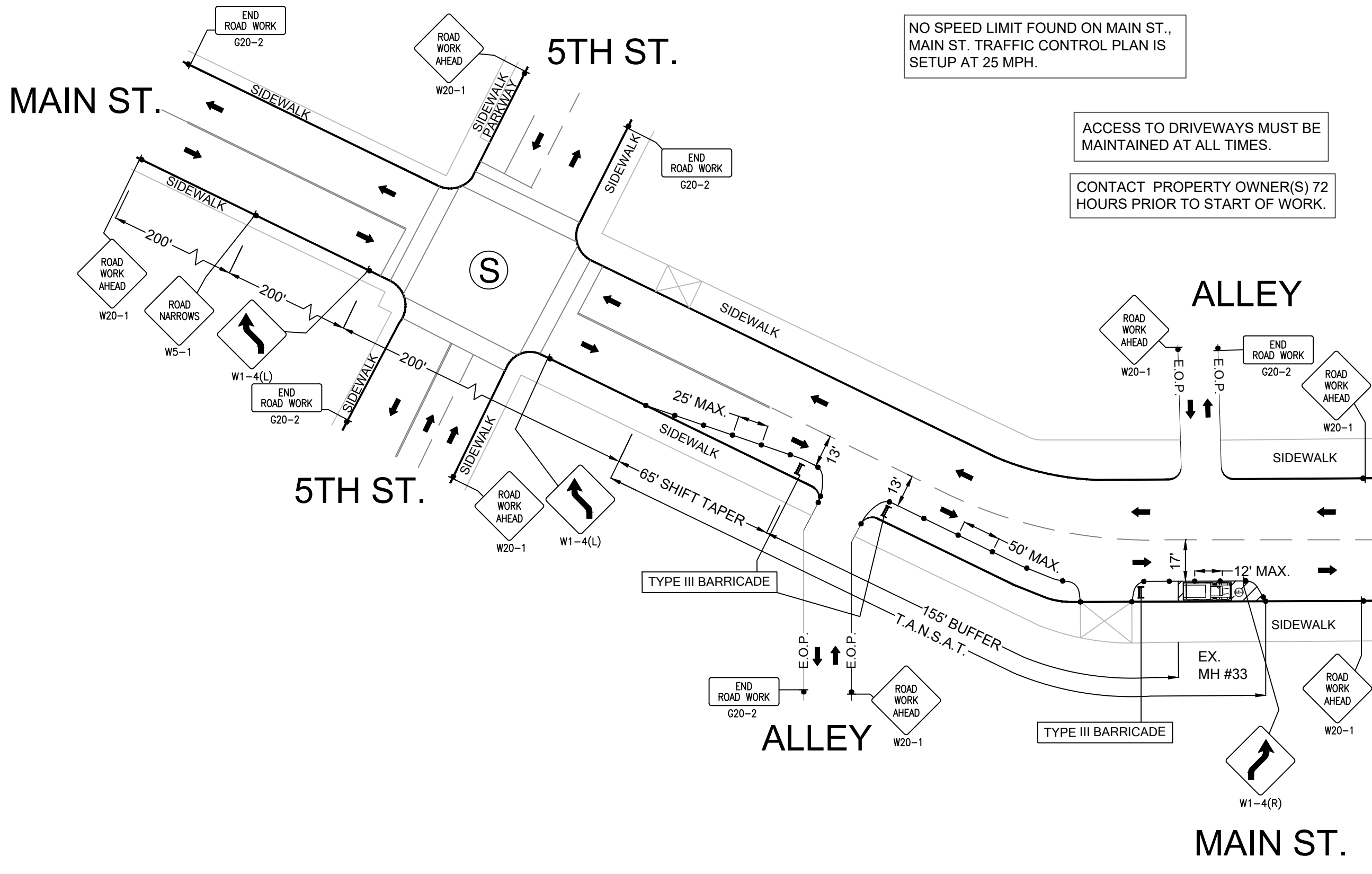

NO SPEED LIMIT FOUND ON MAIN ST.,
 MAIN ST. TRAFFIC CONTROL PLAN IS
 SETUP AT 25 MPH.

ACCESS TO DRIVEWAYS MUST BE
 MAINTAINED AT ALL TIMES.

CONTACT PROPERTY OWNER(S) 72
 HOURS PRIOR TO START OF WORK.

LEGEND

- * PORTABLE FLASHING BEACON (P.F.B.)
- ≡ TYPE III BARRICADE W/SIGN
- ≡ TYPE II BARRICADE W/SIGN
- CHANNELIZING DEVICE
- ▼ TRAFFIC CONE WITH CLIP ON SIGN
- TYPE I W/ SIGN
- EXISTING SIGN
- Ⓢ SIGNALIZED INTERSECTION
- ⚡ FLASHING ARROW BOARD
- ⚡ HIGH LEVEL WARNING DEVICE (FLAGTREE)
- ⚡ FLAGGER
- TANSAT TOW AWAY NO STOPPING ANY TIME
- ⊠ EXISTING DRIVEWAY
- ▨ WORK ZONE (ACTIVITY AREA) LIMITS
- ➔ DIRECTION OF TRAFFIC (NOT PAVEMENT MARKING)

CALL 811 BEFORE YOU DIG.
 WISCONSIN TOLL FREE
 800-242-8511

BRIGHTSPEED

PLANS PREPARED BY:
CHC
 A CONGRUEX COMPANY
 9095 Rio San Diego Dr. Ste 165
 San Diego, CA 92108-1694
 (949) 250-0004 / FAX (949) 250-0006

REVISIONS			
REV.	DESCRIPTION	BY	DATE
0	INITIAL DESIGN	V.D.	2/20/24

BRIGHTSPEED
 CONFIDENTIAL AND PROPRIETARY
 LCRSWIXC

TC-24 OF TC-44

SCALE: 1:40

**539 MAIN ST.
MAIN ST. & 6TH AVE. N)
MH #34 ACCESS
WORK AREA 25 OF 44**

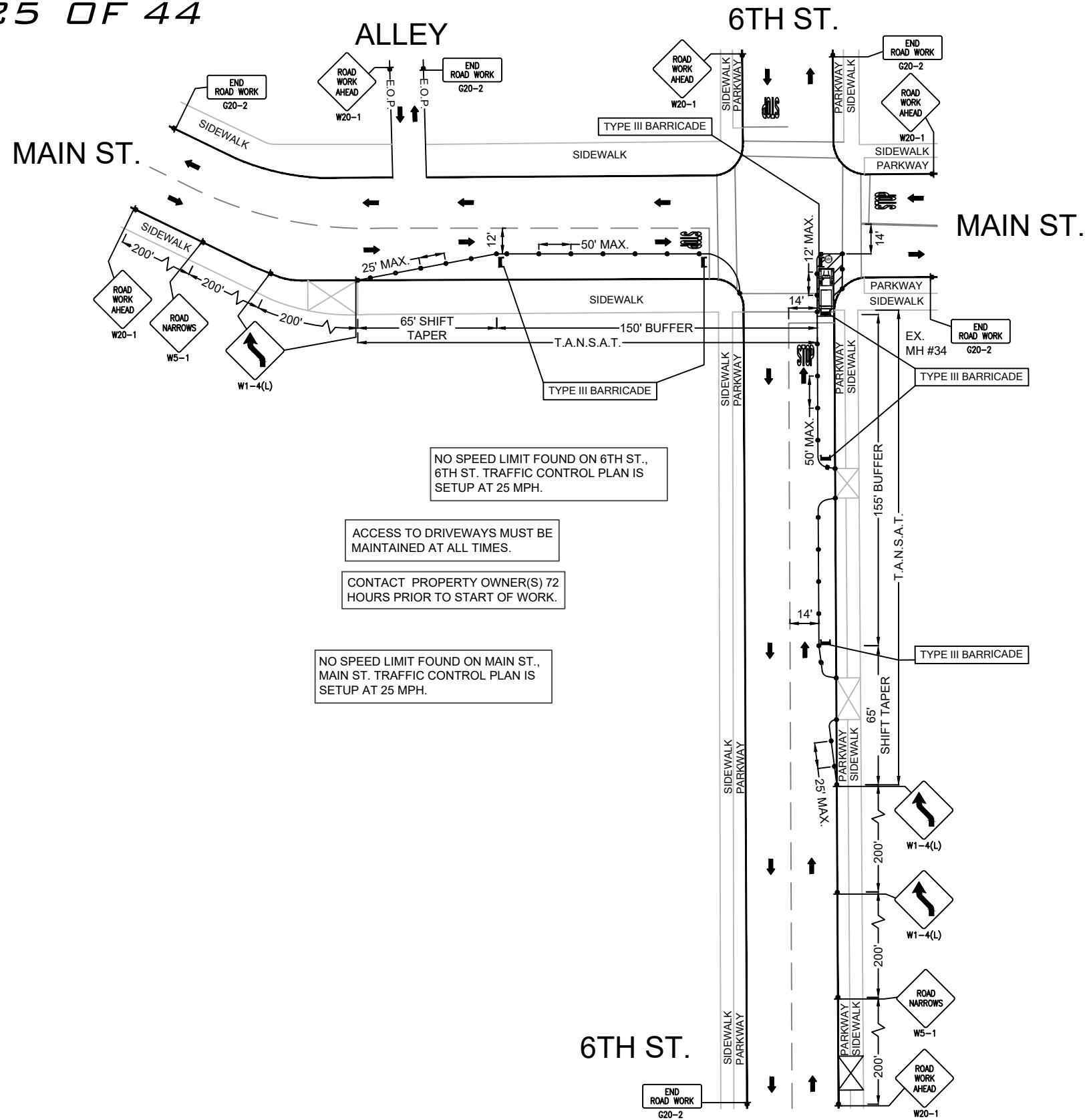

NO SPEED LIMIT FOUND ON 6TH ST.,
6TH ST. TRAFFIC CONTROL PLAN IS
SETUP AT 25 MPH.

ACCESS TO DRIVEWAYS MUST BE
MAINTAINED AT ALL TIMES.

CONTACT PROPERTY OWNER(S) 72
HOURS PRIOR TO START OF WORK.

NO SPEED LIMIT FOUND ON MAIN ST.,
MAIN ST. TRAFFIC CONTROL PLAN IS
SETUP AT 25 MPH.

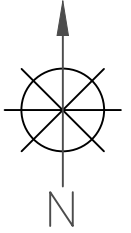

LEGEND

- * PORTABLE FLASHING BEACON (P.F.B.)
- ≡ TYPE III BARRICADE W/SIGN
- ⋈ TYPE II BARRICADE W/SIGN
- CHANNELIZING DEVICE
- ▼ TRAFFIC CONE WITH CLIP ON SIGN
- TYPE I W/ SIGN
- EXISTING SIGN
- ⊙ SIGNALIZED INTERSECTION
- ⚡ FLASHING ARROW BOARD
- ⚡ HIGH LEVEL WARNING DEVICE (FLAGTREE)
- ♠ FLAGGER
- TANSAT TOW AWAY NO STOPPING ANY TIME
- ⊠ EXISTING DRIVEWAY
- ▨ WORK ZONE (ACTIVITY AREA) LIMITS
- ➔ DIRECTION OF TRAFFIC (NOT PAVEMENT MARKING)

CALL 811 BEFORE YOU DIG.
WISCONSIN TOLL FREE
800-242-8511

BRIGHTSPEED

PLANS PREPARED BY:
CHC
A CONGRUEX COMPANY
9095 Rio San Diego Dr. Ste 165
San Diego, CA 92108-1694
(949) 250-0004 / FAX (949) 250-0006

REVISIONS			
REV.	DESCRIPTION	BY	DATE
0	INITIAL DESIGN	V.D.	2/20/24

BRIGHTSPEED
CONFIDENTIAL AND PROPRIETARY
LCRSWIXC

TC-25 OF TC-44

SCALE: 1:60

**629 MAIN ST.
 MAIN ST. & 7TH AVE. N)
 MH #35 & MH #36 ACCESS
 WORK AREA 26 OF 44**

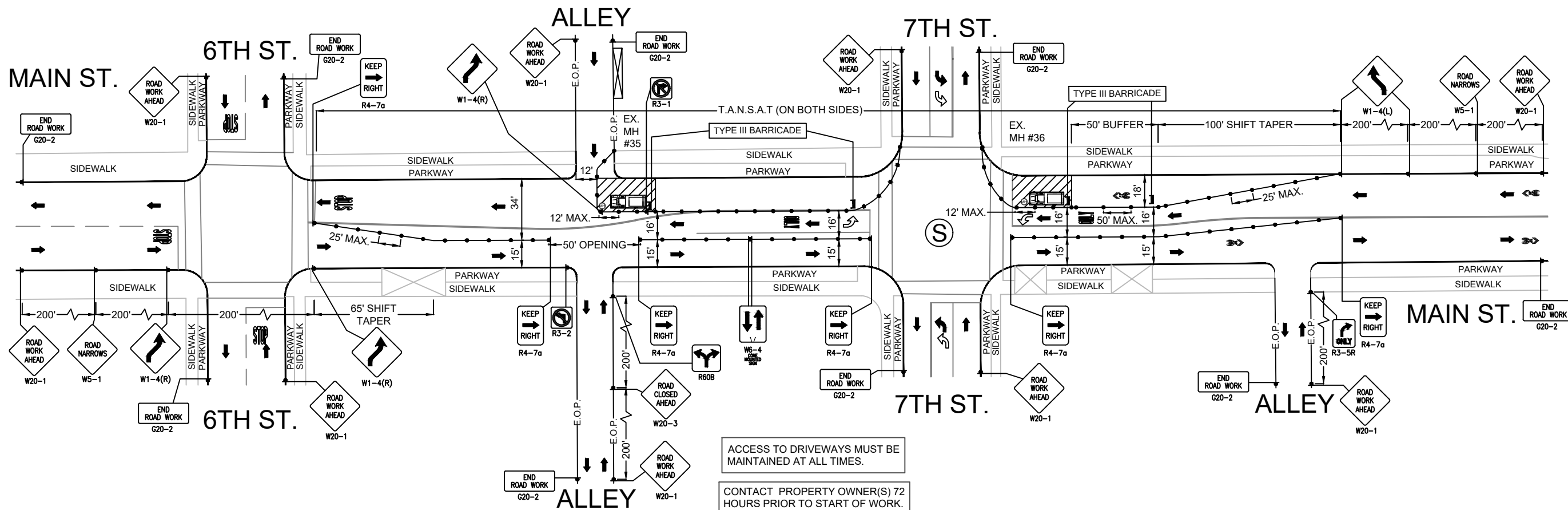

ACCESS TO DRIVEWAYS MUST BE MAINTAINED AT ALL TIMES.

CONTACT PROPERTY OWNER(S) 72 HOURS PRIOR TO START OF WORK.

NO SPEED LIMIT FOUND ON MAIN ST., MAIN ST. TRAFFIC CONTROL PLAN IS SETUP AT 25 MPH.

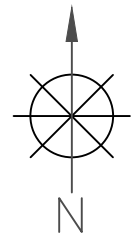

LEGEND

- * PORTABLE FLASHING BEACON (P.F.B.)
- ≡ TYPE III BARRICADE W/SIGN
- ≡ TYPE II BARRICADE W/SIGN
- CHANNELIZING DEVICE
- ▼ TRAFFIC CONE WITH CLIP ON SIGN
- TYPE I W/ SIGN
- EXISTING SIGN
- ⊙ SIGNALIZED INTERSECTION
- ⚡ FLASHING ARROW BOARD
- ⚡ HIGH LEVEL WARNING DEVICE (FLAGTREE)
- ⚡ FLAGGER
- TANSAT TOW AWAY NO STOPPING ANY TIME
- ⊠ EXISTING DRIVEWAY
- ▨ WORK ZONE (ACTIVITY AREA) LIMITS
- DIRECTION OF TRAFFIC (NOT PAVEMENT MARKING)

CALL 811 BEFORE YOU DIG.
 WISCONSIN TOLL FREE
 800-242-8511

BRIGHTSPEED

PLANS PREPARED BY:
CHC
 A CONGRUEX COMPANY
 9095 Rio San Diego Dr. Ste 165
 San Diego, CA 92108-1694
 (949) 250-0004 / FAX (949) 250-0006

REVISIONS			
REV.	DESCRIPTION	BY	DATE
0	INITIAL DESIGN	V.D.	2/20/24

BRIGHTSPEED
 CONFIDENTIAL AND PROPRIETARY
 LCRSWIXC

TC-26 OF TC-44

SCALE: 1:60

622 MAIN ST.
 MAIN ST. & 8TH AVE. N)
 MH #44 ACCESS
 WORK AREA 27 OF 44

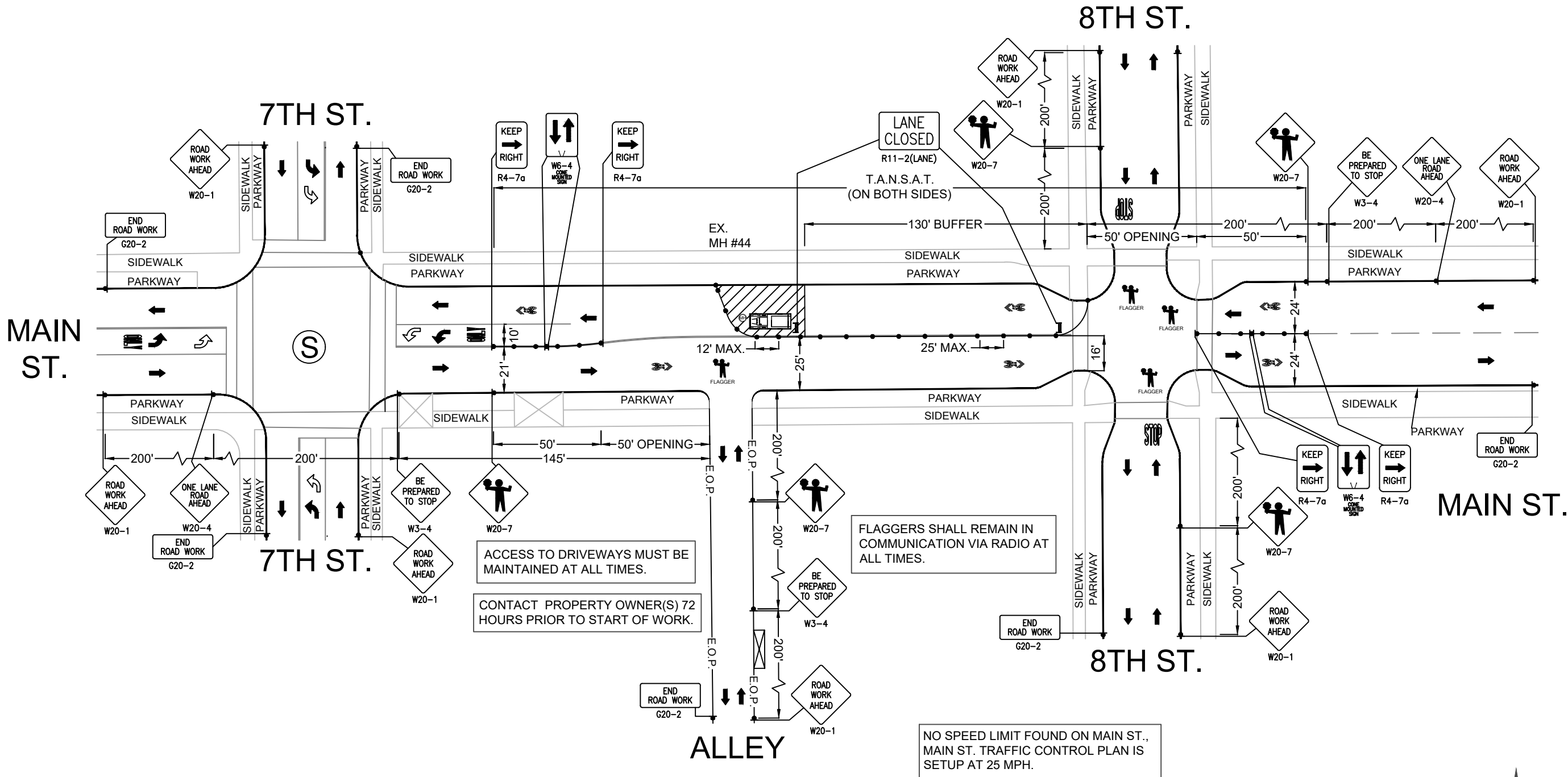

- LEGEND**
- * PORTABLE FLASHING BEACON (P.F.B.)
 - ≡ TYPE III BARRICADE W/SIGN
 - ≡ TYPE II BARRICADE W/SIGN
 - CHANNELIZING DEVICE
 - ▼ TRAFFIC CONE WITH CLIP ON SIGN
 - TYPE I W/ SIGN
 - EXISTING SIGN
 - ⊙ SIGNALIZED INTERSECTION
 - ⊞ FLASHING ARROW BOARD
 - ⚡ HIGH LEVEL WARNING DEVICE (FLAGTREE)
 - ♠ FLAGGER
 - TANSAT TOW AWAY NO STOPPING ANY TIME
 - ⊞ EXISTING DRIVEWAY
 - ▨ WORK ZONE (ACTIVITY AREA) LIMITS
 - DIRECTION OF TRAFFIC (NOT PAVEMENT MARKING)

CALL 811 BEFORE YOU DIG.
 WISCONSIN TOLL FREE
 800-242-8511

BRIGHTSPEED

PLANS PREPARED BY:
CHC
 A CONGRUEX COMPANY
 9095 Rio San Diego Dr. Ste 165
 San Diego, CA 92108-1694
 (949) 250-0004 / FAX (949) 250-0006

REVISIONS			
REV.	DESCRIPTION	BY	DATE
0	INITIAL DESIGN	V.D.	2/20/24

BRIGHTSPEED
 CONFIDENTIAL AND PROPRIETARY
 LCRSWIXC

TC-27 OF TC-44

SCALE: 1:50

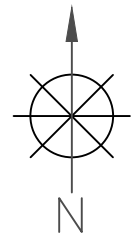

ACCESS TO DRIVEWAYS MUST BE MAINTAINED AT ALL TIMES.
 CONTACT PROPERTY OWNER(S) 72 HOURS PRIOR TO START OF WORK.

FLAGGERS SHALL REMAIN IN COMMUNICATION VIA RADIO AT ALL TIMES.

NO SPEED LIMIT FOUND ON MAIN ST.,
 MAIN ST. TRAFFIC CONTROL PLAN IS SETUP AT 25 MPH.

**820 MAIN ST.
MAIN ST. & 8TH AVE. N)
MH #45 ACCESS
WORK AREA 28 OF 44**

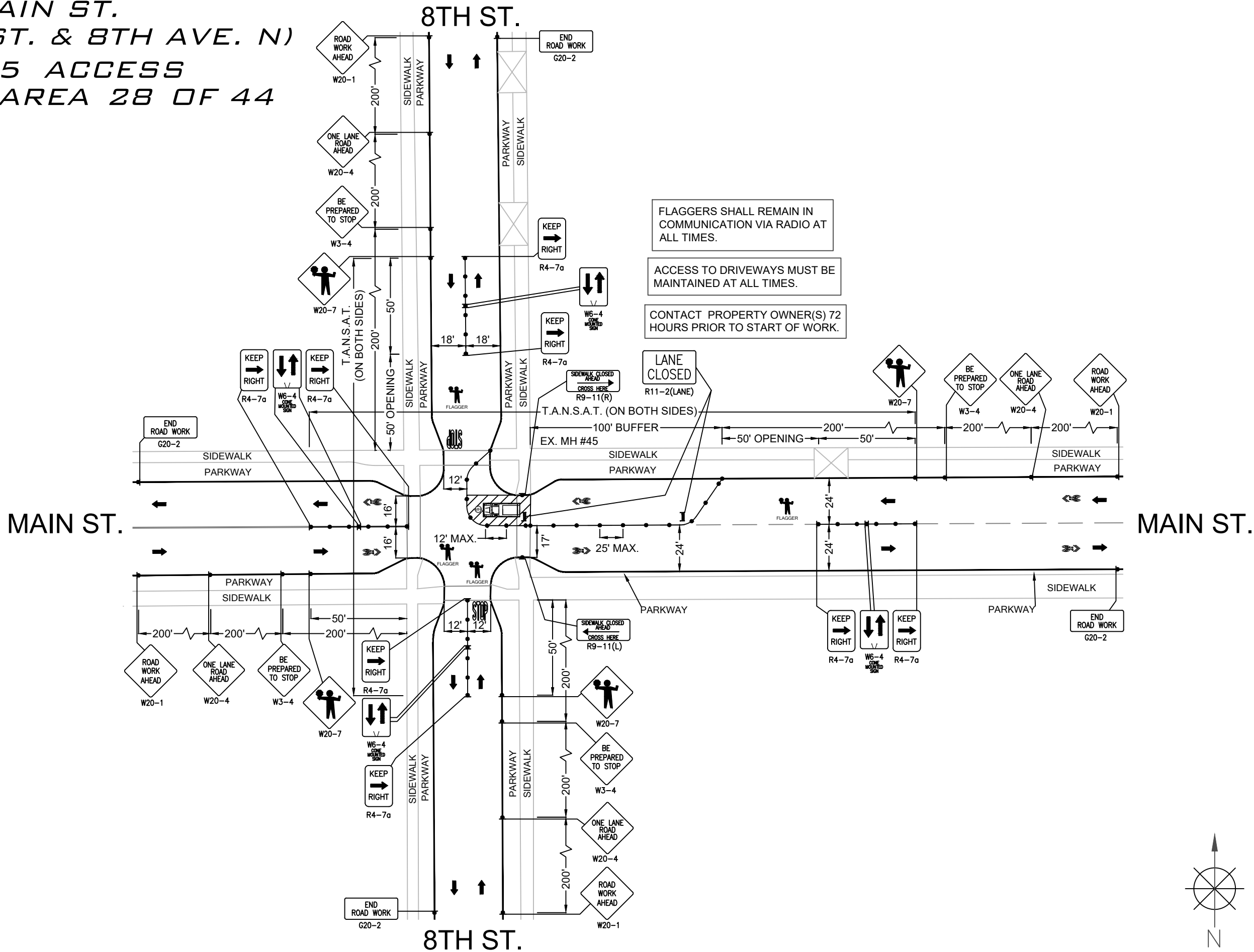

LEGEND

- * PORTABLE FLASHING BEACON (P.F.B.)
- ≡ TYPE III BARRICADE W/SIGN
- ≡ TYPE II BARRICADE W/SIGN
- CHANNELIZING DEVICE
- ▼ TRAFFIC CONE WITH CLIP ON SIGN
- TYPE I W/ SIGN
- EXISTING SIGN
- ⊙ SIGNALIZED INTERSECTION
- ⊞ FLASHING ARROW BOARD
- ⚡ HIGH LEVEL WARNING DEVICE (FLAGTREE)
- ♠ FLAGGER
- TANSAT TOW AWAY NO STOPPING ANY TIME
- ⊞ EXISTING DRIVEWAY
- ▨ WORK ZONE (ACTIVITY AREA) LIMITS
- DIRECTION OF TRAFFIC (NOT PAVEMENT MARKING)

CALL 811 BEFORE YOU DIG.
WISCONSIN TOLL FREE
800-242-8511

BRIGHTSPEED

PLANS PREPARED BY:
CHC
A CONGRUEX COMPANY
9095 Rio San Diego Dr. Ste 165
San Diego, CA 92108-1694
(949) 250-0004 / FAX (949) 250-0006

REVISIONS

REV.	DESCRIPTION	BY	DATE
0	INITIAL DESIGN	V.D.	2/20/24

BRIGHTSPEED
CONFIDENTIAL AND PROPRIETARY
LCRSWIXC

TC-28 OF TC-44

SCALE: 1:50

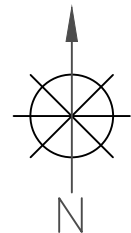

**831 MAIN ST.
MAIN ST. & 9TH AVE. N)
MH #46 ACCESS
WORK AREA 29 OF 44**

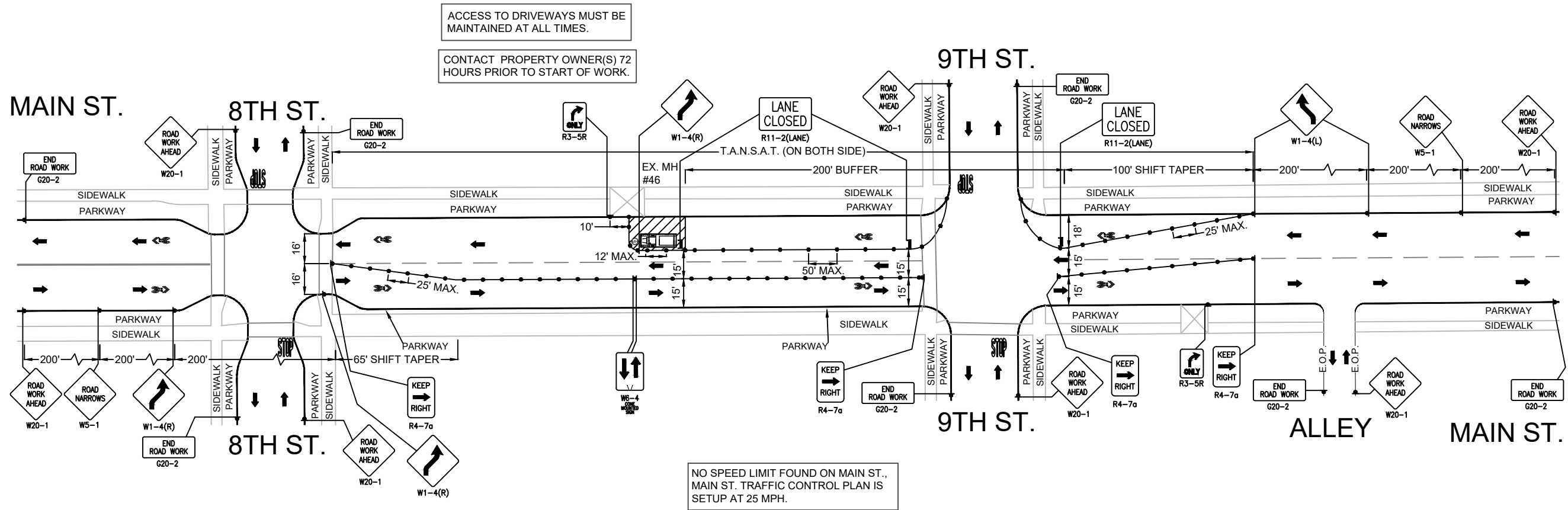

ACCESS TO DRIVEWAYS MUST BE MAINTAINED AT ALL TIMES.

CONTACT PROPERTY OWNER(S) 72 HOURS PRIOR TO START OF WORK.

NO SPEED LIMIT FOUND ON MAIN ST., MAIN ST. TRAFFIC CONTROL PLAN IS SETUP AT 25 MPH.

LEGEND

- * PORTABLE FLASHING BEACON (P.F.B.)
- ≡ TYPE III BARRICADE W/SIGN
- ≡ TYPE II BARRICADE W/SIGN
- CHANNELIZING DEVICE
- ▼ TRAFFIC CONE WITH CLIP ON SIGN
- TYPE I W/ SIGN
- EXISTING SIGN
- ⊙ SIGNALIZED INTERSECTION
- ⊞ FLASHING ARROW BOARD
- ⚡ HIGH LEVEL WARNING DEVICE (FLAGTREE)
- ⚓ FLAGGER
- TANSAT TOW AWAY NO STOPPING ANY TIME
- ⊞ EXISTING DRIVEWAY
- ▨ WORK ZONE (ACTIVITY AREA) LIMITS
- DIRECTION OF TRAFFIC (NOT PAVEMENT MARKING)

CALL 811 BEFORE YOU DIG.
WISCONSIN TOLL FREE
800-242-8511

BRIGHTSPEED

PLANS PREPARED BY:
CHC
A CONGRUEX COMPANY
9095 Rio San Diego Dr. Ste 165
San Diego, CA 92108-1694
(949) 250-0004 / FAX (949) 250-0006

REVISIONS			
REV.	DESCRIPTION	BY	DATE
0	INITIAL DESIGN	V.D.	2/20/24

BRIGHTSPEED
CONFIDENTIAL AND PROPRIETARY

LCRSWIXC

TC-29 OF TC-44

SCALE: 1:60

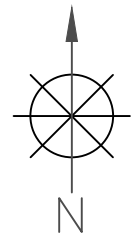

**923 MAIN ST.
MAIN ST. & 10TH AVE. N)
MH #47 & MH #48 ACCESS
WORK AREA 30 OF 44**

ACCESS TO DRIVEWAYS MUST BE MAINTAINED AT ALL TIMES.

CONTACT PROPERTY OWNER(S) 72 HOURS PRIOR TO START OF WORK.

NO SPEED LIMIT FOUND ON MAIN ST., MAIN ST. TRAFFIC CONTROL PLAN IS SETUP AT 25 MPH.

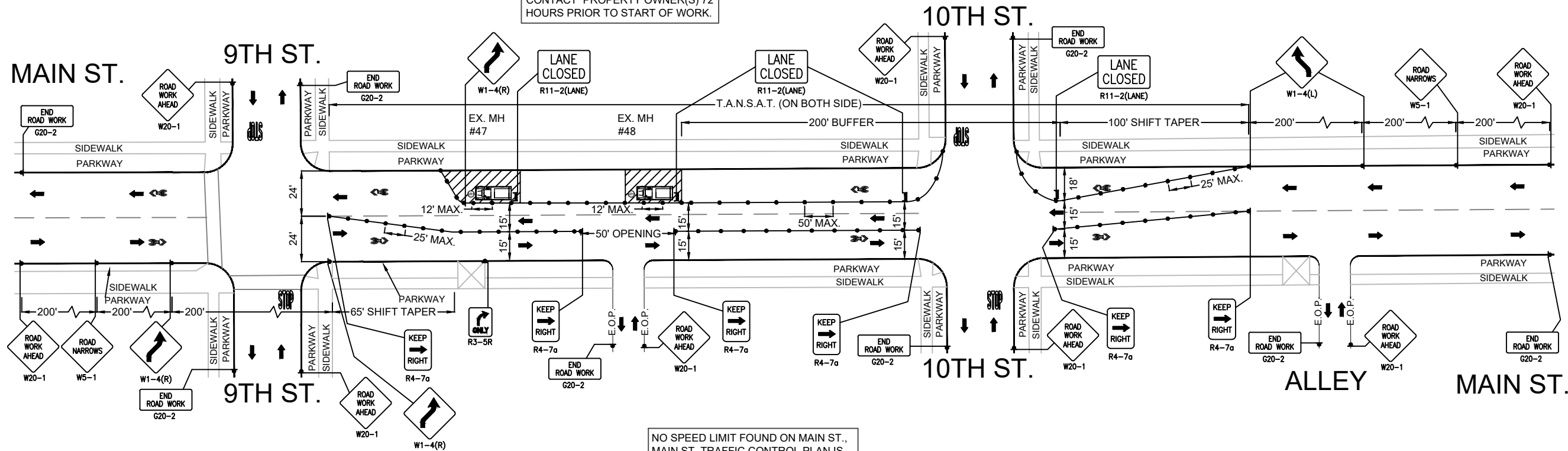

LEGEND

- * PORTABLE FLASHING BEACON (P.F.B.)
- ≡ TYPE III BARRICADE W/SIGN
- ≡ TYPE II BARRICADE W/SIGN
- CHANNELIZING DEVICE
- ▼ TRAFFIC CONE WITH CLIP ON SIGN
- TYPE I W/ SIGN
- EXISTING SIGN
- ⊙ SIGNALIZED INTERSECTION
- ⊞ FLASHING ARROW BOARD
- ⚡ HIGH LEVEL WARNING DEVICE (FLAGTREE)
- ⚓ FLAGGER
- TANSAT TOW AWAY NO STOPPING ANY TIME
- ⊞ EXISTING DRIVEWAY
- ▨ WORK ZONE (ACTIVITY AREA) LIMITS
- DIRECTION OF TRAFFIC (NOT PAVEMENT MARKING)

CALL 811 BEFORE YOU DIG.
WISCONSIN TOLL FREE
800-242-8511

BRIGHTSPEED

PLANS PREPARED BY:
CHC
A CONGRUEX COMPANY
9095 Rio San Diego Dr. Ste 165
San Diego, CA 92108-1694
(949) 250-0004 / FAX (949) 250-0006

REVISIONS

REV.	DESCRIPTION	BY	DATE
0	INITIAL DESIGN	V.D.	2/20/24

BRIGHTSPEED
CONFIDENTIAL AND PROPRIETARY
LCRSWIXC

TC-30 OF TC-44

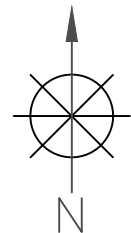

114 3RD ST. S (I-90 ALT.-US-53)
 3RD ST. S (I-90 ALT.-US-53 & PEARL ST.)
 MH #25 ACCESS
 WORK AREA 31 OF 44

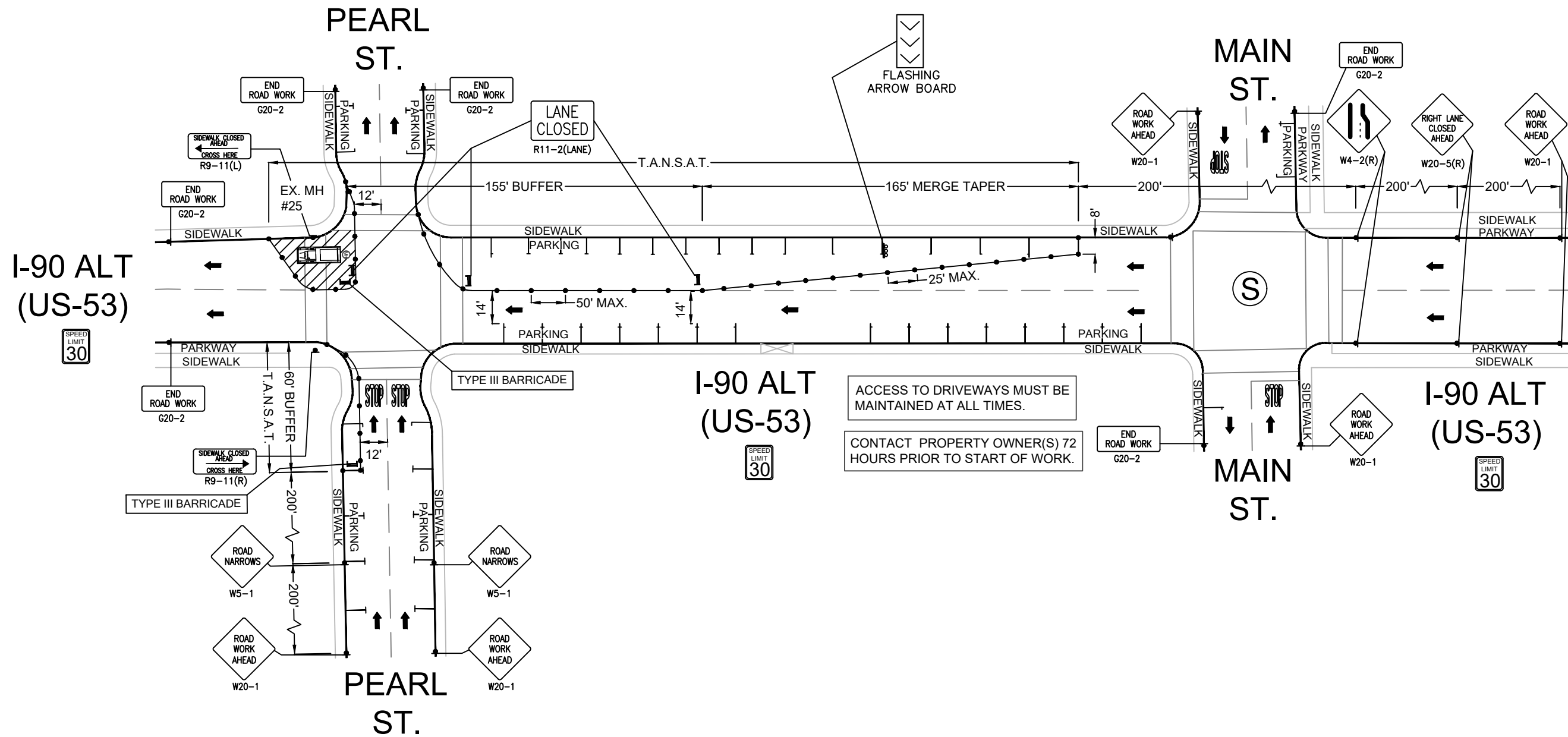

ACCESS TO DRIVEWAYS MUST BE MAINTAINED AT ALL TIMES.
 CONTACT PROPERTY OWNER(S) 72 HOURS PRIOR TO START OF WORK.

LEGEND

- * PORTABLE FLASHING BEACON (P.F.B.)
- ≡ TYPE III BARRICADE W/SIGN
- ≡ TYPE II BARRICADE W/SIGN
- CHANNELIZING DEVICE
- ▼ TRAFFIC CONE WITH CLIP ON SIGN
- TYPE I W/ SIGN
- EXISTING SIGN
- ⊙ SIGNALIZED INTERSECTION
- ⚡ FLASHING ARROW BOARD
- ⚡ HIGH LEVEL WARNING DEVICE (FLAGTREE)
- ⚡ FLAGGER
- TANSAT TOW AWAY NO STOPPING ANY TIME
- ⊠ EXISTING DRIVEWAY
- ▨ WORK ZONE (ACTIVITY AREA) LIMITS
- DIRECTION OF TRAFFIC (NOT PAVEMENT MARKING)

CALL 811 BEFORE YOU DIG.
 WISCONSIN TOLL FREE
 800-242-8511

BRIGHTSPEED

PLANS PREPARED BY:
CHC
 A CONGRUEX COMPANY
 9095 Rio San Diego Dr. Ste 165
 San Diego, CA 92108-1694
 (949) 250-0004 / FAX (949) 250-0006

REVISIONS

REV.	DESCRIPTION	BY	DATE
0	INITIAL DESIGN	V.D.	2/20/24

BRIGHTSPEED
 CONFIDENTIAL AND PROPRIETARY
 LCRSWIXC

TC-31 OF TC-44

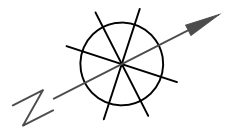

SCALE: 1:50

1011 MAIN ST.
 MAIN ST. & 10TH AVE. N)
 MH #50 ACCESS
 WORK AREA 32 OF 44

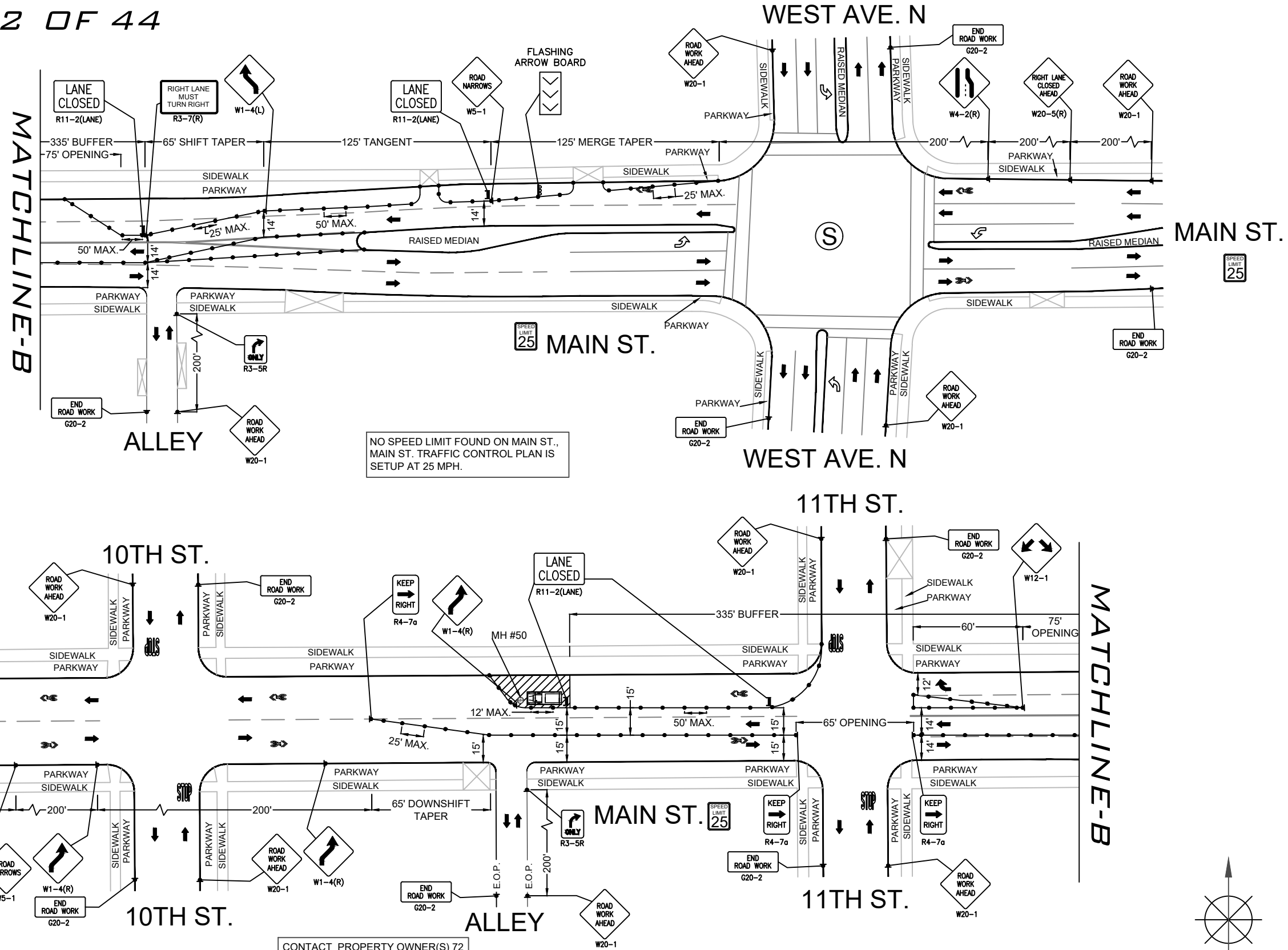

NO SPEED LIMIT FOUND ON MAIN ST.,
 MAIN ST. TRAFFIC CONTROL PLAN IS
 SETUP AT 25 MPH.

CONTACT PROPERTY OWNER(S) 72
 HOURS PRIOR TO START OF WORK.

ACCESS TO DRIVEWAYS MUST BE
 MAINTAINED AT ALL TIMES.

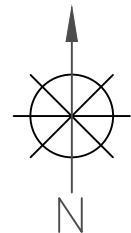

LEGEND

- * PORTABLE FLASHING BEACON (P.F.B.)
- ≡ TYPE III BARRICADE W/SIGN
- ≡ TYPE II BARRICADE W/SIGN
- CHANNELIZING DEVICE
- TRAFFIC CONE WITH CLIP ON SIGN
- ≡ TYPE I W/ SIGN
- ≡ EXISTING SIGN
- ⊙ SIGNALIZED INTERSECTION
- ≡ FLASHING ARROW BOARD
- ⚡ HIGH LEVEL WARNING DEVICE (FLAGTREE)
- ⚡ FLAGGER
- TANSAT TOW AWAY NO STOPPING ANY TIME
- ≡ EXISTING DRIVEWAY
- ▨ WORK ZONE (ACTIVITY AREA) LIMITS
- DIRECTION OF TRAFFIC (NOT PAVEMENT MARKING)

CALL 811 BEFORE YOU DIG.
 WISCONSIN TOLL FREE
 800-242-8511

BRIGHTSPEED

PLANS PREPARED BY:
XCHC
 A CONGRUEX COMPANY
 9095 Rio San Diego Dr. Ste 165
 San Diego, CA 92108-1694
 (949) 250-0004 / FAX (949) 250-0006

REVISIONS			
REV.	DESCRIPTION	BY	DATE
0	INITIAL DESIGN	V.D.	2/20/24

BRIGHTSPEED
 CONFIDENTIAL AND PROPRIETARY

LCRSWIXC

TC-32 OF TC-44

SCALE: 1:60

**604 2ND ST. S
FRONT ST. S & KING ST.
MH #81 ACCESS
WORK AREA 33 OF 44**

PEDESTRIAN CONTROL NOTES:

A DEDICATED INDIVIDUAL WILL BE ASSIGNED THE RESPONSIBILITY OF ESCORTING PEDESTRIANS THROUGH THE WORK AREA IN ACCORDANCE WITH THREE MAJOR CONSIDERATIONS:

1. PEDESTRIANS SHOULD NOT BE LED INTO DIRECT CONFLICT WITH WORK SITE VEHICLES, EQUIPMENT OR OPERATIONS
2. PEDESTRIANS SHOULD NOT BE LED INTO DIRECT CONFLICT WITH MAINLINE TRAFFIC MOVING THROUGH OR AROUND THE WORK SITE.
3. PEDESTRIANS SHOULD BE PROVIDED WITH A REASONABLY SAFE, CONVENIENT AND ACCESSIBLE PATH THAT REPLICATES AS NEARLY AS PRACTICAL THE MOST DESIRABLE CHARACTERISTICS OF THE EXISTING SIDEWALK OR FOOTPATH

FLAGGER TO ASSIST PEDESTRIANS THROUGH WORK AREA (SEE PED NOTES)

NO SPEED LIMIT FOUND ON FRONT ST. S, FRONT ST. S TRAFFIC CONTROL PLAN IS SETUP AT 25 MPH.

ACCESS TO DRIVEWAYS MUST BE MAINTAINED AT ALL TIMES.

CONTACT PROPERTY OWNER(S) 72 HOURS PRIOR TO START OF WORK.

MH #81 IS +/- 565' S/E OF THE C/L OF KING ST.

NO SPEED LIMIT FOUND ON CROSS ST., CROSS ST. TRAFFIC CONTROL PLAN IS SETUP AT 25 MPH.

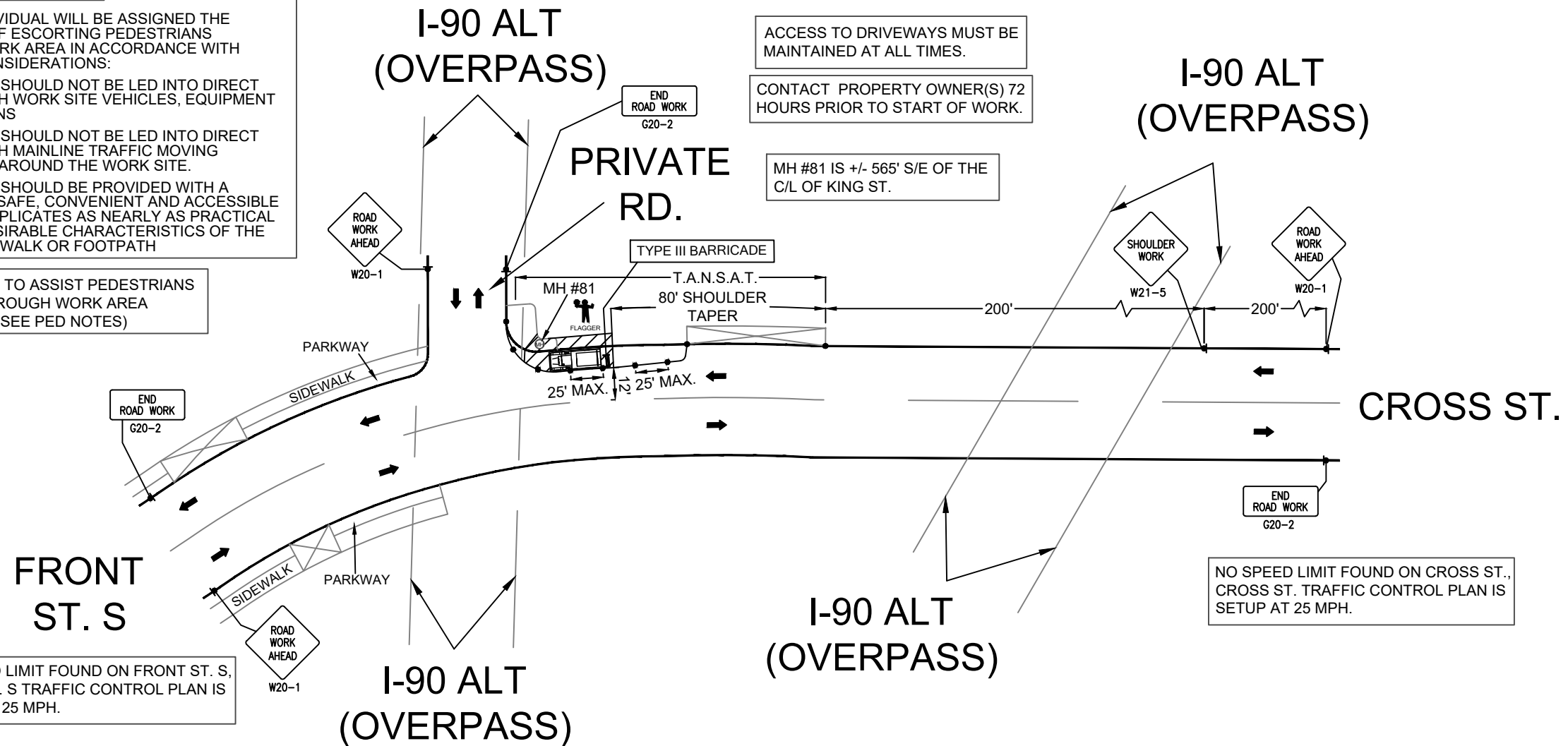

LEGEND

- * PORTABLE FLASHING BEACON (P.F.B.)
- ≡ TYPE III BARRICADE W/SIGN
- ≡ TYPE II BARRICADE W/SIGN
- CHANNELIZING DEVICE
- ▼ TRAFFIC CONE WITH CLIP ON SIGN
- TYPE I W/ SIGN
- EXISTING SIGN
- ⊙ SIGNALIZED INTERSECTION
- ⊞ FLASHING ARROW BOARD
- ⚡ HIGH LEVEL WARNING DEVICE (FLAGTREE)
- ♠ FLAGGER
- TANSAT TOW AWAY NO STOPPING ANY TIME
- ⊞ EXISTING DRIVEWAY
- ▨ WORK ZONE (ACTIVITY AREA) LIMITS
- DIRECTION OF TRAFFIC (NOT PAVEMENT MARKING)

CALL 811 BEFORE YOU DIG.
WISCONSIN TOLL FREE
800-242-8511

BRIGHTSPEED

PLANS PREPARED BY:
CHC
A CONGRUEX COMPANY
9095 Rio San Diego Dr. Ste 165
San Diego, CA 92108-1694
(949) 250-0004 / FAX (949) 250-0006

REVISIONS			
REV.	DESCRIPTION	BY	DATE
0	INITIAL DESIGN	V.D.	2/20/24

BRIGHTSPEED
CONFIDENTIAL AND PROPRIETARY
LCRSWIXC

TC-33 OF TC-44

SCALE: 1:50

**502 FRONT ST. S
FRONT ST. S & KING ST.
MH #80 ACCESS
WORK AREA 34 OF 44**

ACCESS TO DRIVEWAYS MUST BE MAINTAINED AT ALL TIMES.

CONTACT PROPERTY OWNER(S) 72 HOURS PRIOR TO START OF WORK.

MH #80 IS +/- 340' S/E OF THE C/L OF KING ST.

PEDESTRIAN CONTROL NOTES:

A DEDICATED INDIVIDUAL WILL BE ASSIGNED THE RESPONSIBILITY OF ESCORTING PEDESTRIANS THROUGH THE WORK AREA IN ACCORDANCE WITH THREE MAJOR CONSIDERATIONS:

1. PEDESTRIANS SHOULD NOT BE LED INTO DIRECT CONFLICT WITH WORK SITE VEHICLES, EQUIPMENT OR OPERATIONS
2. PEDESTRIANS SHOULD NOT BE LED INTO DIRECT CONFLICT WITH MAINLINE TRAFFIC MOVING THROUGH OR AROUND THE WORK SITE.
3. PEDESTRIANS SHOULD BE PROVIDED WITH A REASONABLY SAFE, CONVENIENT AND ACCESSIBLE PATH THAT REPLICATES AS NEARLY AS PRACTICAL THE MOST DESIRABLE CHARACTERISTICS OF THE EXISTING SIDEWALK OR FOOTPATH

FLAGGER TO ASSIST PEDESTRIANS THROUGH WORK AREA (SEE PED NOTES)

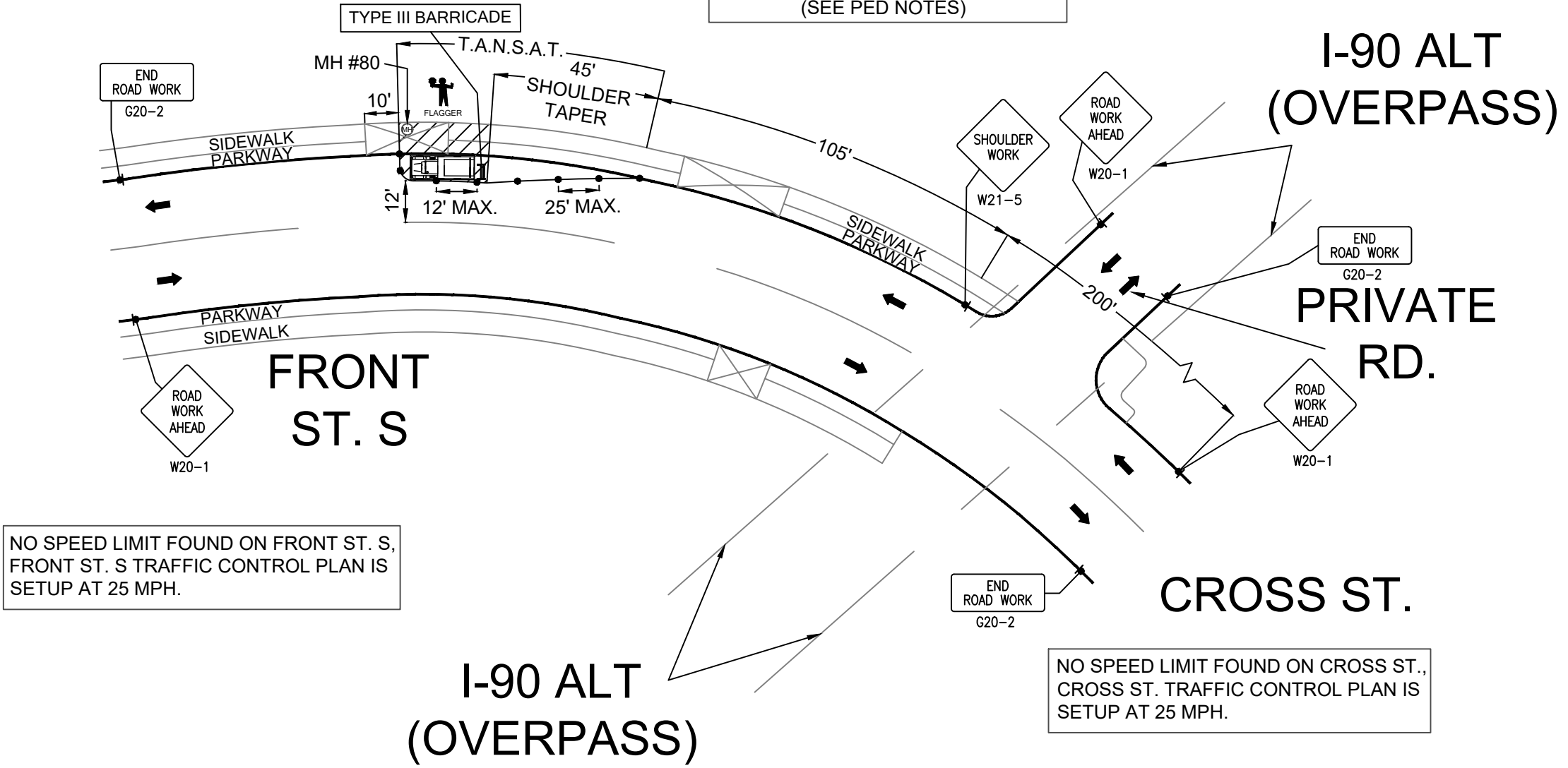

NO SPEED LIMIT FOUND ON FRONT ST. S, FRONT ST. S TRAFFIC CONTROL PLAN IS SETUP AT 25 MPH.

NO SPEED LIMIT FOUND ON CROSS ST., CROSS ST. TRAFFIC CONTROL PLAN IS SETUP AT 25 MPH.

LEGEND

- * PORTABLE FLASHING BEACON (P.F.B.)
- ≡ TYPE III BARRICADE W/SIGN
- ≡ TYPE II BARRICADE W/SIGN
- CHANNELIZING DEVICE
- ▼ TRAFFIC CONE WITH CLIP ON SIGN
- TYPE I W/ SIGN
- EXISTING SIGN
- ⊙ SIGNALIZED INTERSECTION
- ⊞ FLASHING ARROW BOARD
- ⚡ HIGH LEVEL WARNING DEVICE (FLAGTREE)
- ♠ FLAGGER
- TANSAT TOW AWAY NO STOPPING ANY TIME
- ⊞ EXISTING DRIVEWAY
- ▨ WORK ZONE (ACTIVITY AREA) LIMITS
- DIRECTION OF TRAFFIC (NOT PAVEMENT MARKING)

CALL 811 BEFORE YOU DIG.
WISCONSIN TOLL FREE
800-242-8511

BRIGHTSPEED

PLANS PREPARED BY:
XCHC
A CONGRUEX COMPANY
9095 Rio San Diego Dr. Ste 165
San Diego, CA 92108-1694
(949) 250-0004 / FAX (949) 250-0006

REVISIONS			
REV.	DESCRIPTION	BY	DATE
0	INITIAL DESIGN	V.D.	2/20/24

BRIGHTSPEED
CONFIDENTIAL AND PROPRIETARY
LCRSWIXC

TC-34 OF TC-44

SCALE: 1:40

**501 FRONT ST. S
FRONT ST. S & KING ST.
MH #79 ACCESS
WORK AREA 35 OF 44**

ACCESS TO DRIVEWAYS MUST BE MAINTAINED AT ALL TIMES.

CONTACT PROPERTY OWNER(S) 72 HOURS PRIOR TO START OF WORK.

MH #79 IS +/- 170' S/E OF THE C/L OF KING ST.

PEDESTRIAN CONTROL NOTES:

A DEDICATED INDIVIDUAL WILL BE ASSIGNED THE RESPONSIBILITY OF ESCORTING PEDESTRIANS THROUGH THE WORK AREA IN ACCORDANCE WITH THREE MAJOR CONSIDERATIONS:

1. PEDESTRIANS SHOULD NOT BE LED INTO DIRECT CONFLICT WITH WORK SITE VEHICLES, EQUIPMENT OR OPERATIONS
2. PEDESTRIANS SHOULD NOT BE LED INTO DIRECT CONFLICT WITH MAINLINE TRAFFIC MOVING THROUGH OR AROUND THE WORK SITE.
3. PEDESTRIANS SHOULD BE PROVIDED WITH A REASONABLY SAFE, CONVENIENT AND ACCESSIBLE PATH THAT REPLICATES AS NEARLY AS PRACTICAL THE MOST DESIRABLE CHARACTERISTICS OF THE EXISTING SIDEWALK OR FOOTPATH

FLAGGER TO ASSIST PEDESTRIANS THROUGH WORK AREA (SEE PED NOTES)

FRONT ST. S

FRONT ST. S

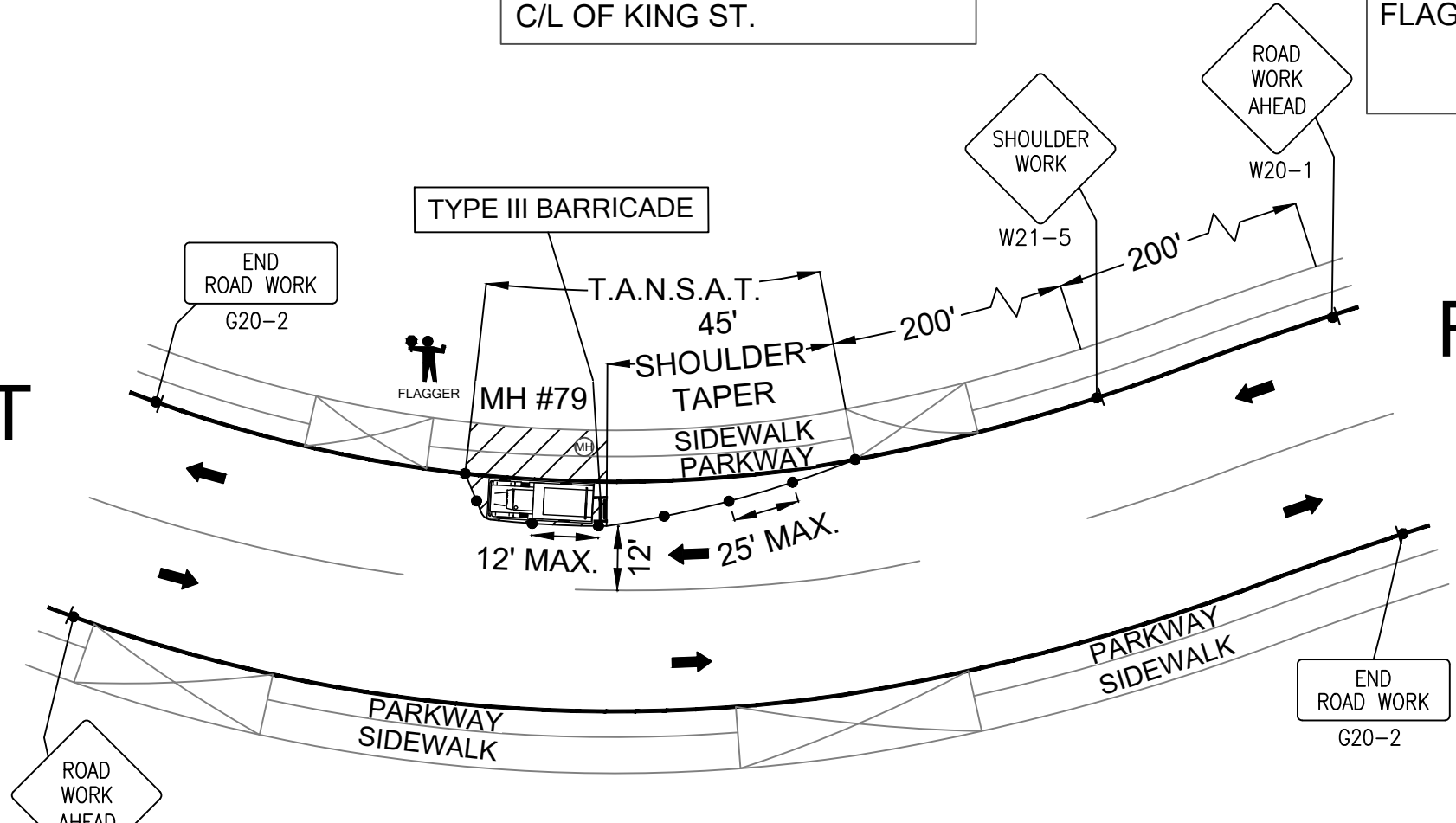

NO SPEED LIMIT FOUND ON FRONT ST. S, FRONT ST. S TRAFFIC CONTROL PLAN IS SETUP AT 25 MPH.

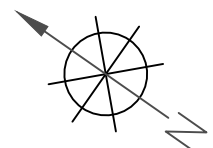

LEGEND

- * PORTABLE FLASHING BEACON (P.F.B.)
- ≡ TYPE III BARRICADE W/SIGN
- ≡ TYPE II BARRICADE W/SIGN
- CHANNELIZING DEVICE
- ▼ TRAFFIC CONE WITH CLIP ON SIGN
- TYPE I W/ SIGN
- EXISTING SIGN
- ⊙ SIGNALIZED INTERSECTION
- ⇄ FLASHING ARROW BOARD
- ⚡ HIGH LEVEL WARNING DEVICE (FLAGTREE)
- ♠ FLAGGER
- TANSAT TOW AWAY NO STOPPING ANY TIME
- ⊠ EXISTING DRIVEWAY
- ▨ WORK ZONE (ACTIVITY AREA) LIMITS
- ➔ DIRECTION OF TRAFFIC (NOT PAVEMENT MARKING)

CALL 811 BEFORE YOU DIG.
WISCONSIN TOLL FREE
800-242-8511

BRIGHTSPEED

PLANS PREPARED BY:
CHC
A CONGRUEX COMPANY
9095 Rio San Diego Dr. Ste 165
San Diego, CA 92108-1694
(949) 250-0004 / FAX (949) 250-0006

REVISIONS

REV.	DESCRIPTION	BY	DATE
0	INITIAL DESIGN	V.D.	2/20/24

BRIGHTSPEED
CONFIDENTIAL AND PROPRIETARY
LCRSWIXC

TC-35 OF TC-44

FRONT ST. S

428 FRONT ST. S KING ST. & FRONT ST. S MH #54 ACCESS WORK AREA 36 OF 44

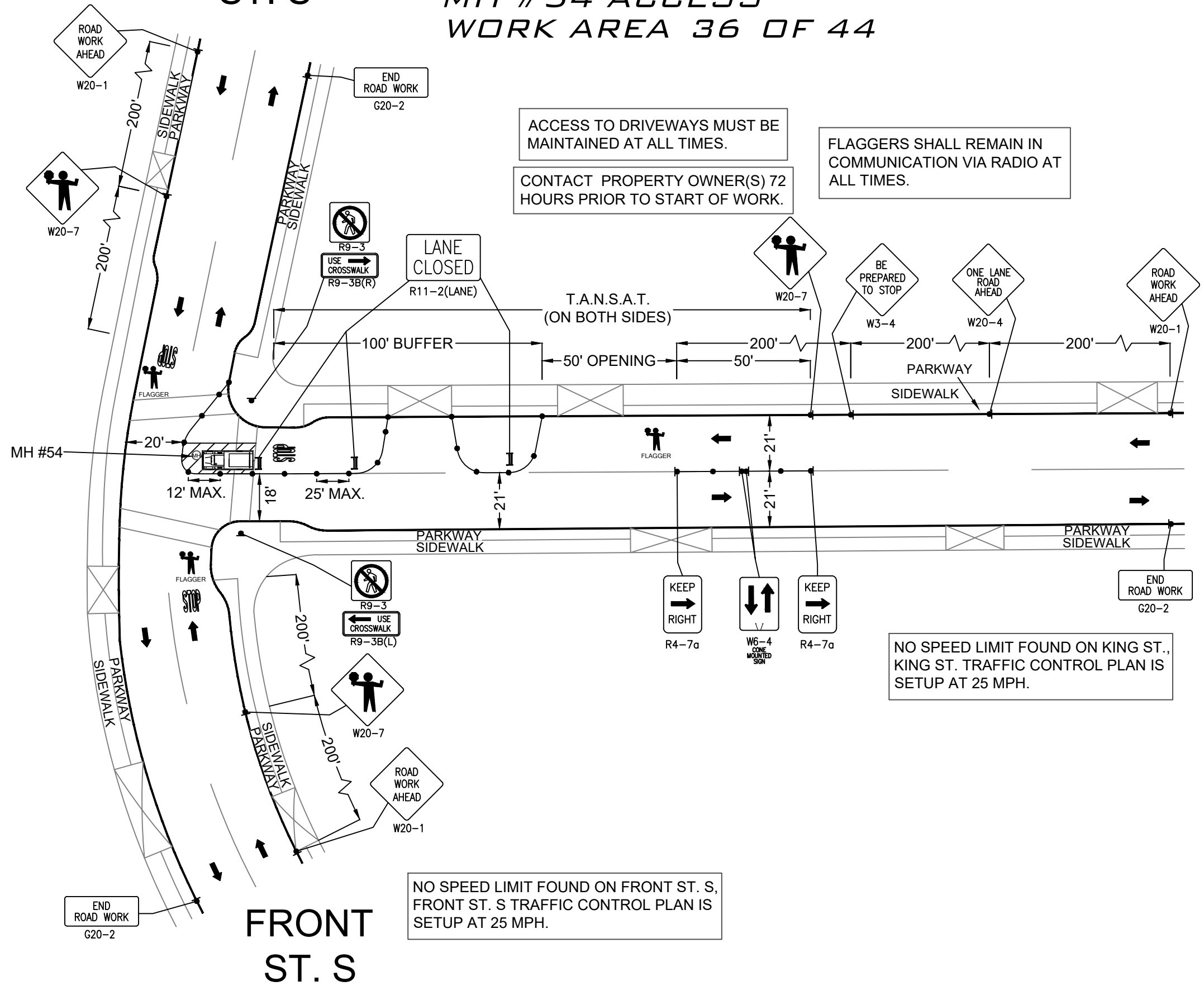

ACCESS TO DRIVEWAYS MUST BE MAINTAINED AT ALL TIMES.

CONTACT PROPERTY OWNER(S) 72 HOURS PRIOR TO START OF WORK.

FLAGGERS SHALL REMAIN IN COMMUNICATION VIA RADIO AT ALL TIMES.

NO SPEED LIMIT FOUND ON KING ST., KING ST. TRAFFIC CONTROL PLAN IS SETUP AT 25 MPH.

NO SPEED LIMIT FOUND ON FRONT ST. S, FRONT ST. S TRAFFIC CONTROL PLAN IS SETUP AT 25 MPH.

LEGEND

- * PORTABLE FLASHING BEACON (P.F.B.)
- ▬ TYPE III BARRICADE W/SIGN
- ⌘ TYPE II BARRICADE W/SIGN
- CHANNELIZING DEVICE
- ▼ TRAFFIC CONE WITH CLIP ON SIGN
- ▬ TYPE I W/ SIGN
- ▭ EXISTING SIGN
- ⊙ SIGNALIZED INTERSECTION
- ⚡ FLASHING ARROW BOARD
- ⚡ HIGH LEVEL WARNING DEVICE (FLAGTREE)
- ♠ FLAGGER
- TANSAT TOW AWAY NO STOPPING ANY TIME
- ▭ EXISTING DRIVEWAY
- ▨ WORK ZONE (ACTIVITY AREA) LIMITS
- ➔ DIRECTION OF TRAFFIC (NOT PAVEMENT MARKING)

CALL 811 BEFORE YOU DIG.
WISCONSIN TOLL FREE
800-242-8511

BRIGHTSPEED

PLANS PREPARED BY:
XCHC
 A CONGRUEX COMPANY
 9095 Rio San Diego Dr. Ste 165
 San Diego, CA 92108-1694
 (949) 250-0004 / FAX (949) 250-0006

REVISIONS			
REV.	DESCRIPTION	BY	DATE
0	INITIAL DESIGN	V.D.	2/20/24

BRIGHTSPEED
 CONFIDENTIAL AND PROPRIETARY
 LCRSWIXC

TC-36 OF TC-44

SCALE: 1:40

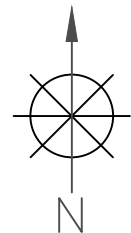

424 2ND ST. S
 KING ST. & 2ND ST. S
 MH #55 ACCESS
 WORK AREA 37 OF 44

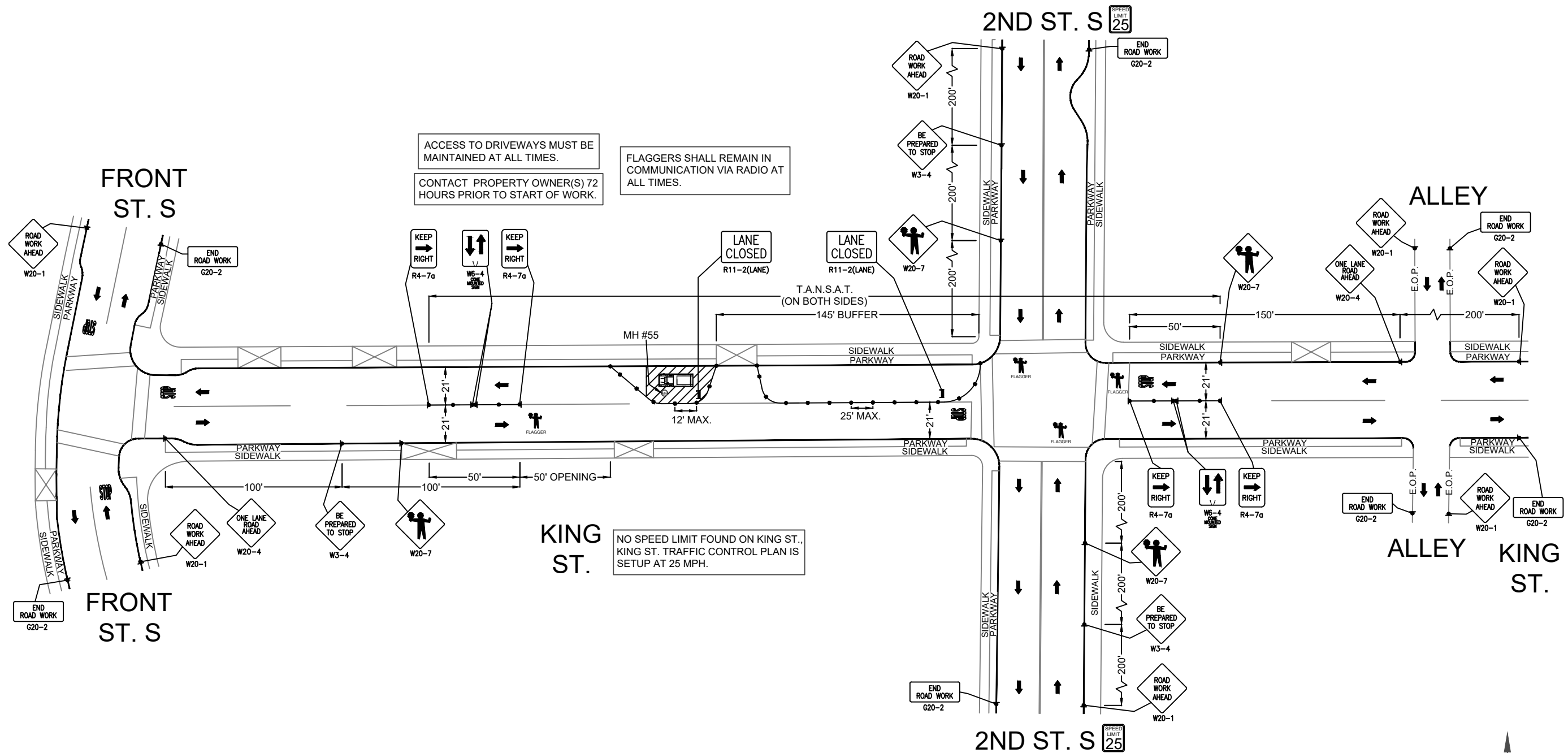

ACCESS TO DRIVEWAYS MUST BE MAINTAINED AT ALL TIMES.
 CONTACT PROPERTY OWNER(S) 72 HOURS PRIOR TO START OF WORK.

FLAGGERS SHALL REMAIN IN COMMUNICATION VIA RADIO AT ALL TIMES.

NO SPEED LIMIT FOUND ON KING ST., KING ST. TRAFFIC CONTROL PLAN IS SETUP AT 25 MPH.

LEGEND

- * PORTABLE FLASHING BEACON (P.F.B.)
- ≡ TYPE III BARRICADE W/SIGN
- ≡ TYPE II BARRICADE W/SIGN
- CHANNELIZING DEVICE
- ▼ TRAFFIC CONE WITH CLIP ON SIGN
- TYPE I W/ SIGN
- EXISTING SIGN
- ⊙ SIGNALIZED INTERSECTION
- ⊞ FLASHING ARROW BOARD
- ⚡ HIGH LEVEL WARNING DEVICE (FLAGTREE)
- ♠ FLAGGER
- TANSAT TOW AWAY NO STOPPING ANY TIME
- ⊞ EXISTING DRIVEWAY
- ▨ WORK ZONE (ACTIVITY AREA) LIMITS
- DIRECTION OF TRAFFIC (NOT PAVEMENT MARKING)

CALL 811 BEFORE YOU DIG.
 WISCONSIN TOLL FREE
 800-242-8511

BRIGHTSPEED

PLANS PREPARED BY:

XCHC
 A CONGRUEX COMPANY
 9095 Rio San Diego Dr. Ste 165
 San Diego, CA 92108-1694
 (949) 250-0004 / FAX (949) 250-0006

REVISIONS

REV.	DESCRIPTION	BY	DATE
0	INITIAL DESIGN	V.D.	2/20/24

BRIGHTSPEED
 CONFIDENTIAL AND PROPRIETARY

LCRSWIXC

TC-37 OF TC-44

SCALE: 1:60

324 3RD ST. S (I-90 ALT) KING ST. & 3RD ST. S (I-90 ALT) MH #57 ACCESS WORK AREA 38 OF 44

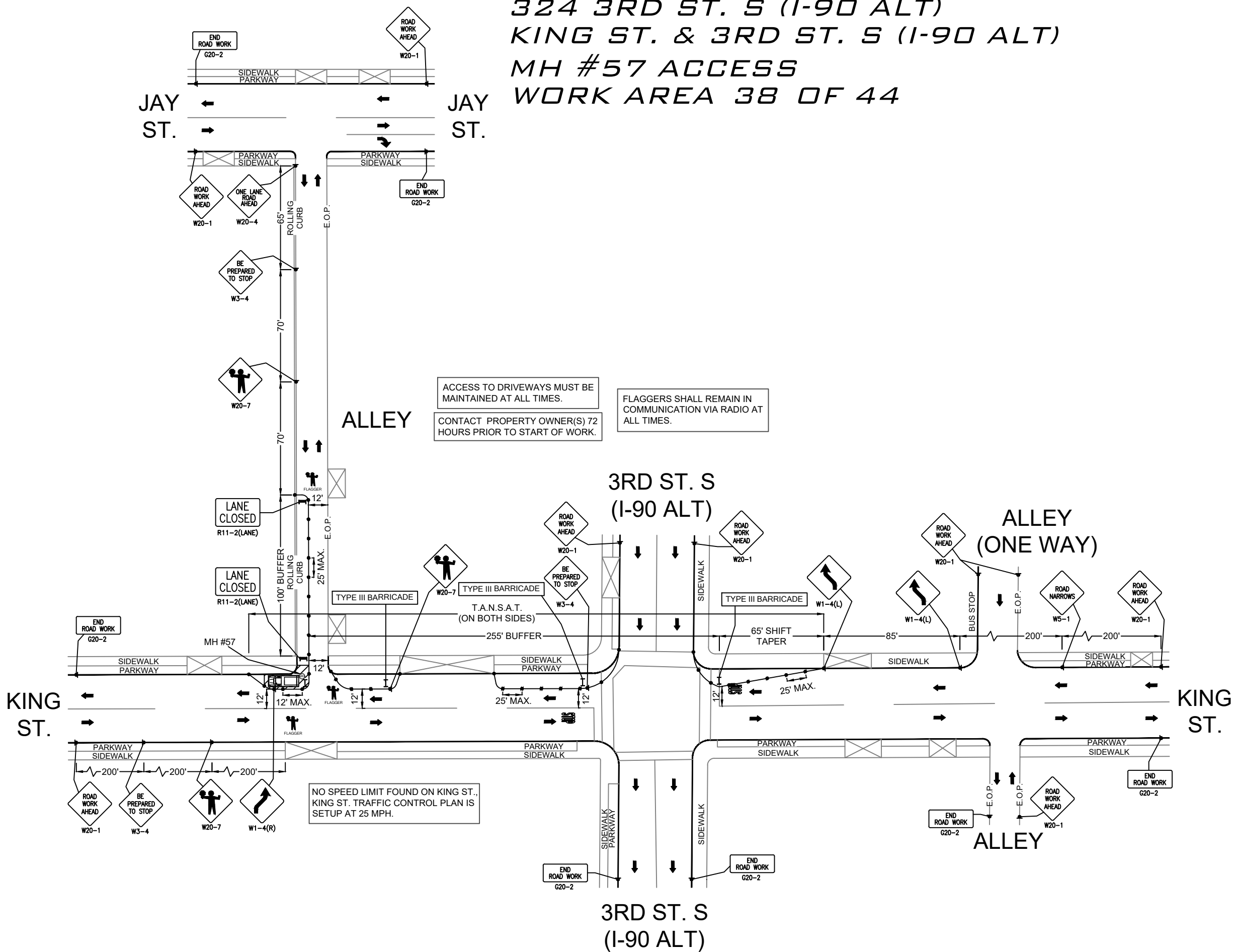

ACCESS TO DRIVEWAYS MUST BE MAINTAINED AT ALL TIMES.
CONTACT PROPERTY OWNER(S) 72 HOURS PRIOR TO START OF WORK.

FLAGGERS SHALL REMAIN IN COMMUNICATION VIA RADIO AT ALL TIMES.

NO SPEED LIMIT FOUND ON KING ST., KING ST. TRAFFIC CONTROL PLAN IS SETUP AT 25 MPH.

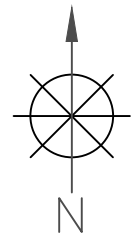

LEGEND

- * PORTABLE FLASHING BEACON (P.F.B.)
- ≡ TYPE III BARRICADE W/SIGN
- ≡ TYPE II BARRICADE W/SIGN
- CHANNELIZING DEVICE
- ▼ TRAFFIC CONE WITH CLIP ON SIGN
- TYPE I W/ SIGN
- EXISTING SIGN
- ⊙ SIGNALIZED INTERSECTION
- ⊞ FLASHING ARROW BOARD
- ⚡ HIGH LEVEL WARNING DEVICE (FLAGTREE)
- ♠ FLAGGER
- TANSAT TOW AWAY NO STOPPING ANY TIME
- ⊞ EXISTING DRIVEWAY
- ▨ WORK ZONE (ACTIVITY AREA) LIMITS
- ➔ DIRECTION OF TRAFFIC (NOT PAVEMENT MARKING)

CALL 811 BEFORE YOU DIG.
WISCONSIN TOLL FREE
800-242-8511

BRIGHTSPEED

PLANS PREPARED BY:
XCHC
A CONGRUEX COMPANY
9095 Rio San Diego Dr. Ste 165
San Diego, CA 92108-1694
(949) 250-0004 / FAX (949) 250-0006

REVISIONS			
REV.	DESCRIPTION	BY	DATE
0	INITIAL DESIGN	V.D.	2/20/24

BRIGHTSPEED
CONFIDENTIAL AND PROPRIETARY
LCRSWIXC

TC-38 OF TC-44

SCALE: 1:60

515 2ND ST. S
 KING ST. & 2ND ST. S
 MH #56 ACCESS
 WORK AREA 39 OF 44

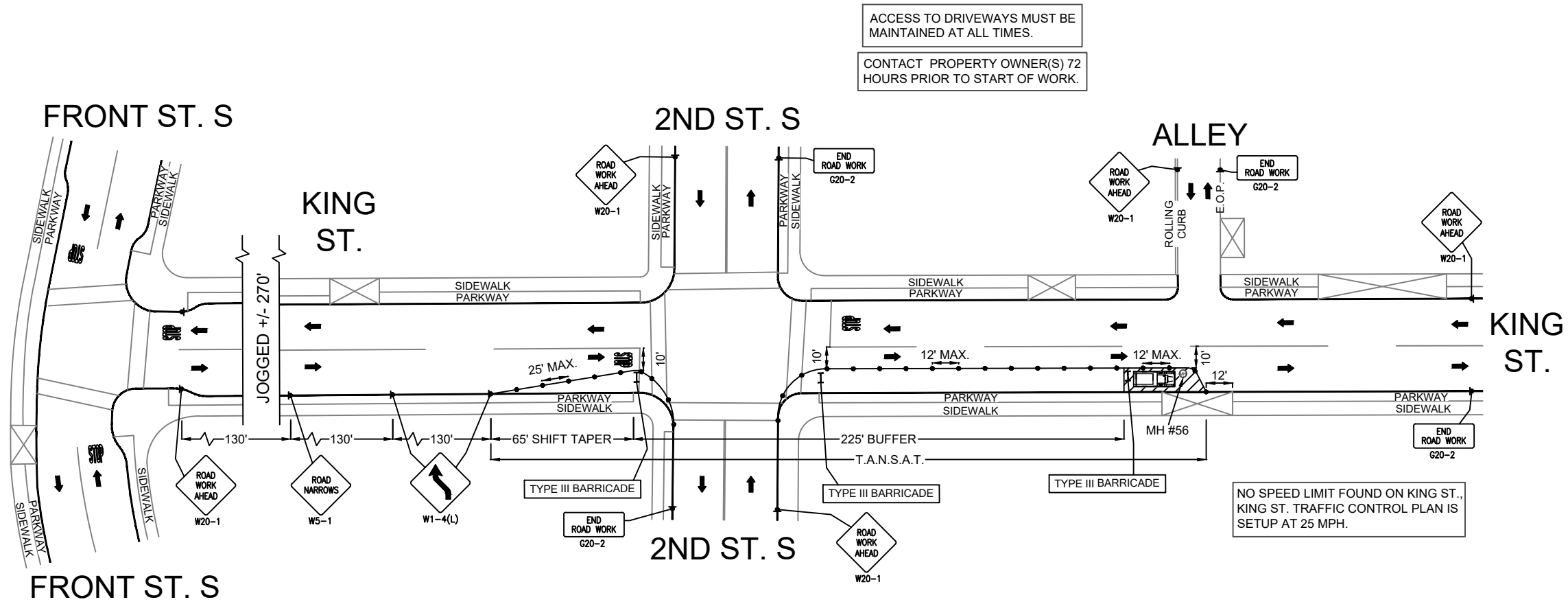

ACCESS TO DRIVEWAYS MUST BE MAINTAINED AT ALL TIMES.
 CONTACT PROPERTY OWNER(S) 72 HOURS PRIOR TO START OF WORK.

NO SPEED LIMIT FOUND ON KING ST., KING ST. TRAFFIC CONTROL PLAN IS SETUP AT 25 MPH.

- LEGEND**
- * PORTABLE FLASHING BEACON (P.F.B.)
 - ≡ TYPE III BARRICADE W/SIGN
 - ≡ TYPE II BARRICADE W/SIGN
 - CHANNELIZING DEVICE
 - ▼ TRAFFIC CONE WITH CLIP ON SIGN
 - TYPE I W/ SIGN
 - EXISTING SIGN
 - ⊙ SIGNALIZED INTERSECTION
 - ⊞ FLASHING ARROW BOARD
 - ⚡ HIGH LEVEL WARNING DEVICE (FLAGTREE)
 - ⚠ FLAGGER
 - TANSAT TOW AWAY NO STOPPING ANY TIME
 - ⊞ EXISTING DRIVEWAY
 - ▨ WORK ZONE (ACTIVITY AREA) LIMITS
 - DIRECTION OF TRAFFIC (NOT PAVEMENT MARKING)

CALL 811 BEFORE YOU DIG.
 WISCONSIN TOLL FREE
 800-242-8511

BRIGHTSPEED

PLANS PREPARED BY:
CHC
 A CONGRUEX COMPANY
 9095 Rio San Diego Dr. Ste 165
 San Diego, CA 92108-1694
 (949) 250-0004 / FAX (949) 250-0006

REVISIONS			
REV.	DESCRIPTION	BY	DATE
0	INITIAL DESIGN	V.D.	2/20/24

BRIGHTSPEED
 CONFIDENTIAL AND PROPRIETARY
 LCRSWIXC

TC-39 OF TC-44

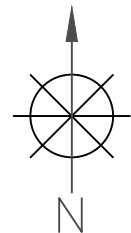

304 3RD ST. S (I-90 ALT)
 3RD ST. S (I-90 ALT) & KING ST.
 MH #59 ACCESS
 WORK AREA 40 OF 44

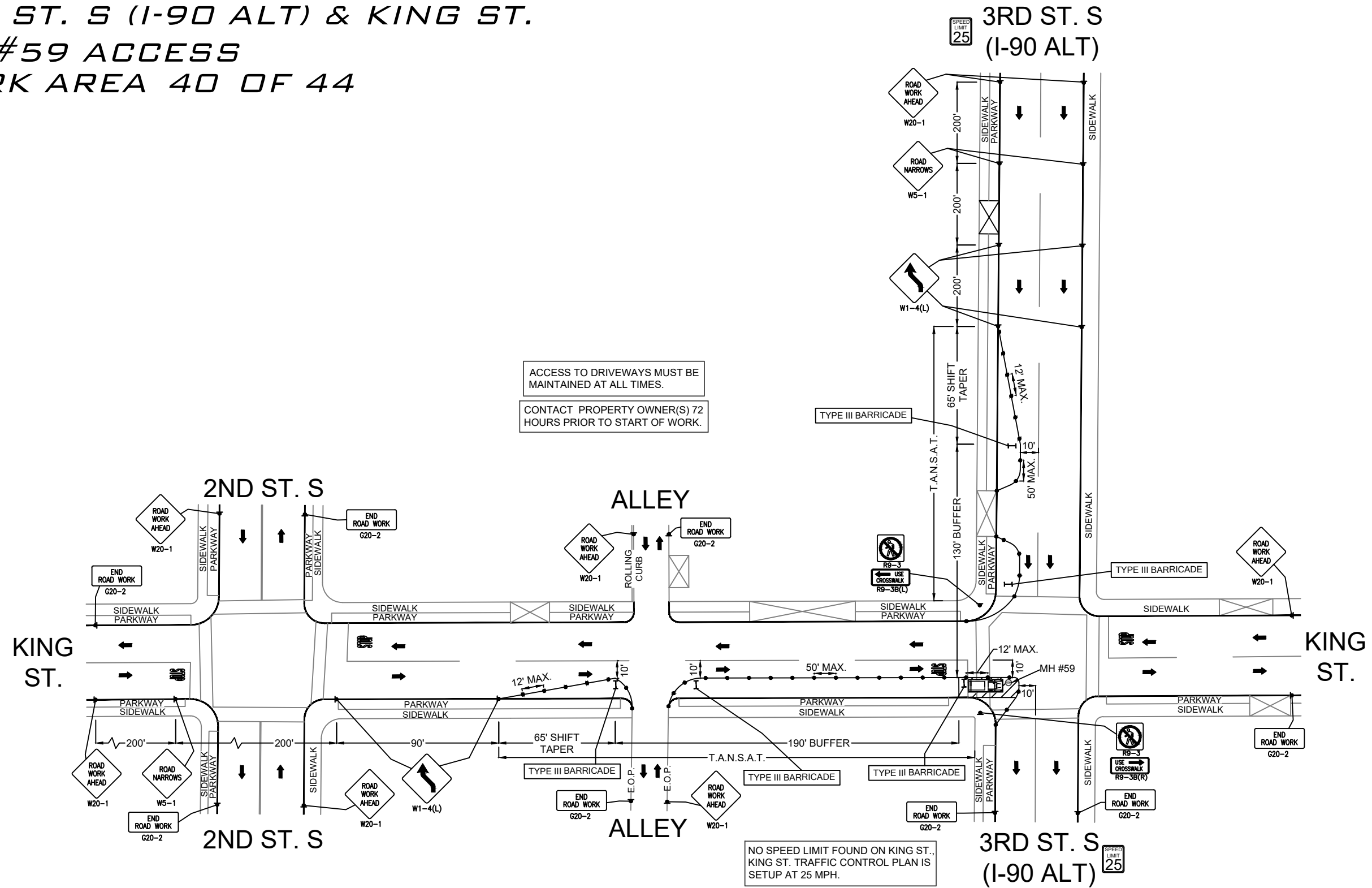

ACCESS TO DRIVEWAYS MUST BE MAINTAINED AT ALL TIMES.

CONTACT PROPERTY OWNER(S) 72 HOURS PRIOR TO START OF WORK.

NO SPEED LIMIT FOUND ON KING ST.,
 KING ST. TRAFFIC CONTROL PLAN IS
 SETUP AT 25 MPH.

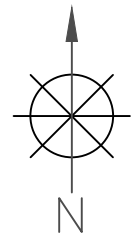

- * PORTABLE FLASHING BEACON (P.F.B.)
- ≡ TYPE III BARRICADE W/SIGN
- ≡ TYPE II BARRICADE W/SIGN
- CHANNELIZING DEVICE
- ▼ TRAFFIC CONE WITH CLIP ON SIGN
- TYPE I W/ SIGN
- EXISTING SIGN
- ⊙ SIGNALIZED INTERSECTION
- ⊞ FLASHING ARROW BOARD
- ⚡ HIGH LEVEL WARNING DEVICE (FLAGTREE)
- ⚓ FLAGGER
- TANSAT TOW AWAY NO STOPPING ANY TIME
- ⊞ EXISTING DRIVEWAY
- ▨ WORK ZONE (ACTIVITY AREA) LIMITS
- DIRECTION OF TRAFFIC (NOT PAVEMENT MARKING)

CALL 811 BEFORE YOU DIG.
 WISCONSIN TOLL FREE
 800-242-8511

BRIGHTSPEED

PLANS PREPARED BY:
XCHC
 A CONGRUEX COMPANY
 9095 Rio San Diego Dr. Ste 165
 San Diego, CA 92108-1694
 (949) 250-0004 / FAX (949) 250-0006

REVISIONS			
REV.	DESCRIPTION	BY	DATE
0	INITIAL DESIGN	V.D.	2/20/24

BRIGHTSPEED
 CONFIDENTIAL AND PROPRIETARY
 LCRSWIXC

TC-40 OF TC-44

**323 KING ST.
KING ST. & 3RD ST. S (I-90 ALT)
MH #60 ACCESS
WORK AREA 41 OF 44**

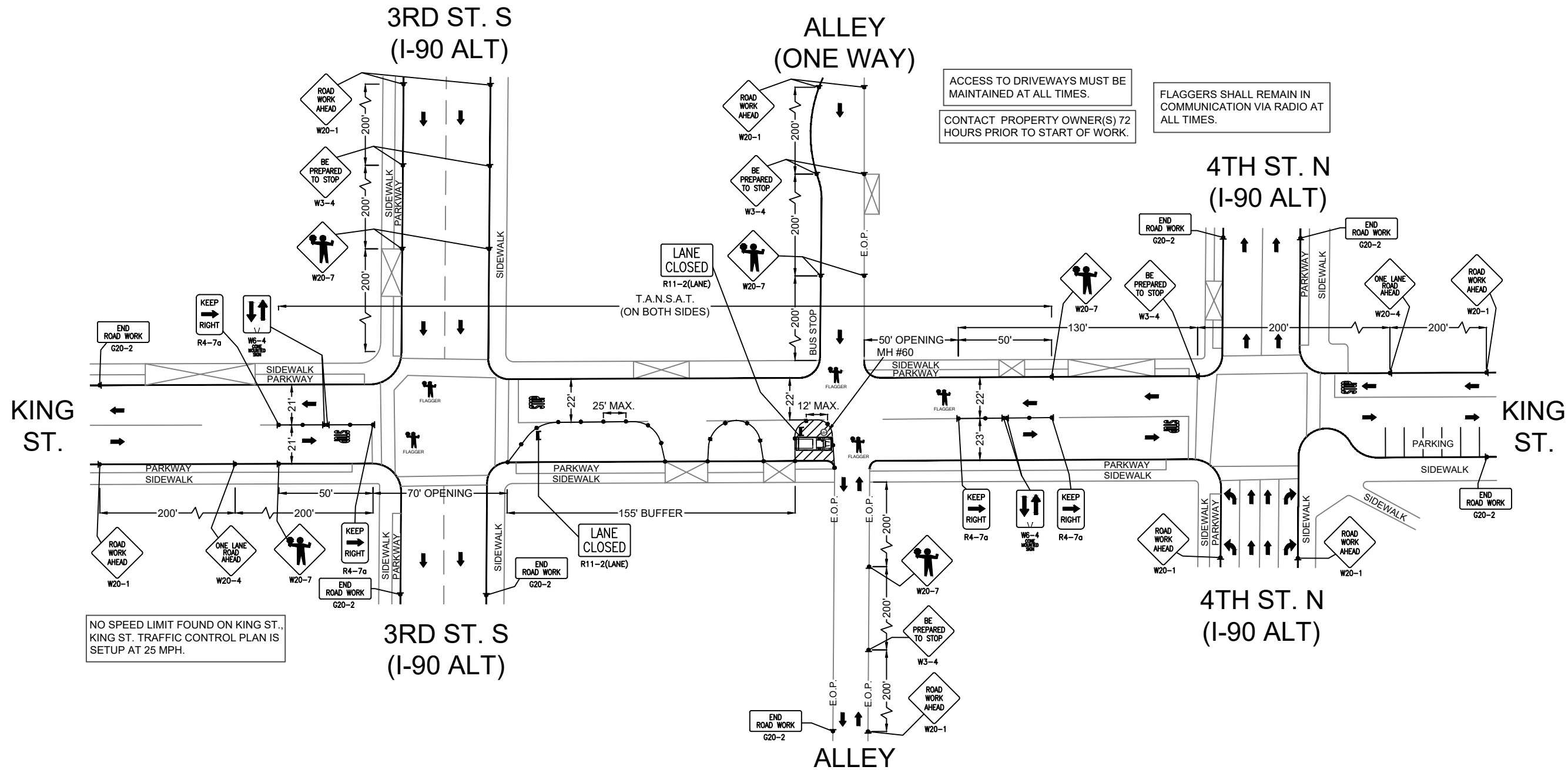

ACCESS TO DRIVEWAYS MUST BE MAINTAINED AT ALL TIMES.
CONTACT PROPERTY OWNER(S) 72 HOURS PRIOR TO START OF WORK.

FLAGGERS SHALL REMAIN IN COMMUNICATION VIA RADIO AT ALL TIMES.

NO SPEED LIMIT FOUND ON KING ST., KING ST. TRAFFIC CONTROL PLAN IS SETUP AT 25 MPH.

LEGEND

- * PORTABLE FLASHING BEACON (P.F.B.)
- ≡ TYPE III BARRICADE W/SIGN
- ≡ TYPE II BARRICADE W/SIGN
- CHANNELIZING DEVICE
- ▼ TRAFFIC CONE WITH CLIP ON SIGN
- TYPE I W/ SIGN
- EXISTING SIGN
- ⊙ SIGNALIZED INTERSECTION
- ⊞ FLASHING ARROW BOARD
- ⚡ HIGH LEVEL WARNING DEVICE (FLAGTREE)
- ♠ FLAGGER
- TANSAT TOW AWAY NO STOPPING ANY TIME
- ⊞ EXISTING DRIVEWAY
- ▨ WORK ZONE (ACTIVITY AREA) LIMITS
- DIRECTION OF TRAFFIC (NOT PAVEMENT MARKING)

CALL 811 BEFORE YOU DIG.
WISCONSIN TOLL FREE
800-242-8511

BRIGHTSPEED

PLANS PREPARED BY:
CHC
A CONGRUEX COMPANY
9095 Rio San Diego Dr. Ste 165
San Diego, CA 92108-1694
(949) 250-0004 / FAX (949) 250-0006

REVISIONS			
REV.	DESCRIPTION	BY	DATE
0	INITIAL DESIGN	V.D.	2/20/24

BRIGHTSPEED
CONFIDENTIAL AND PROPRIETARY
LCRSWIXC

TC-41 OF TC-44

SCALE: 1:60

419 KING ST.
 KING ST. & 5TH AVE. S
 MH #67 ACCESS
 WORK AREA 42 OF 44

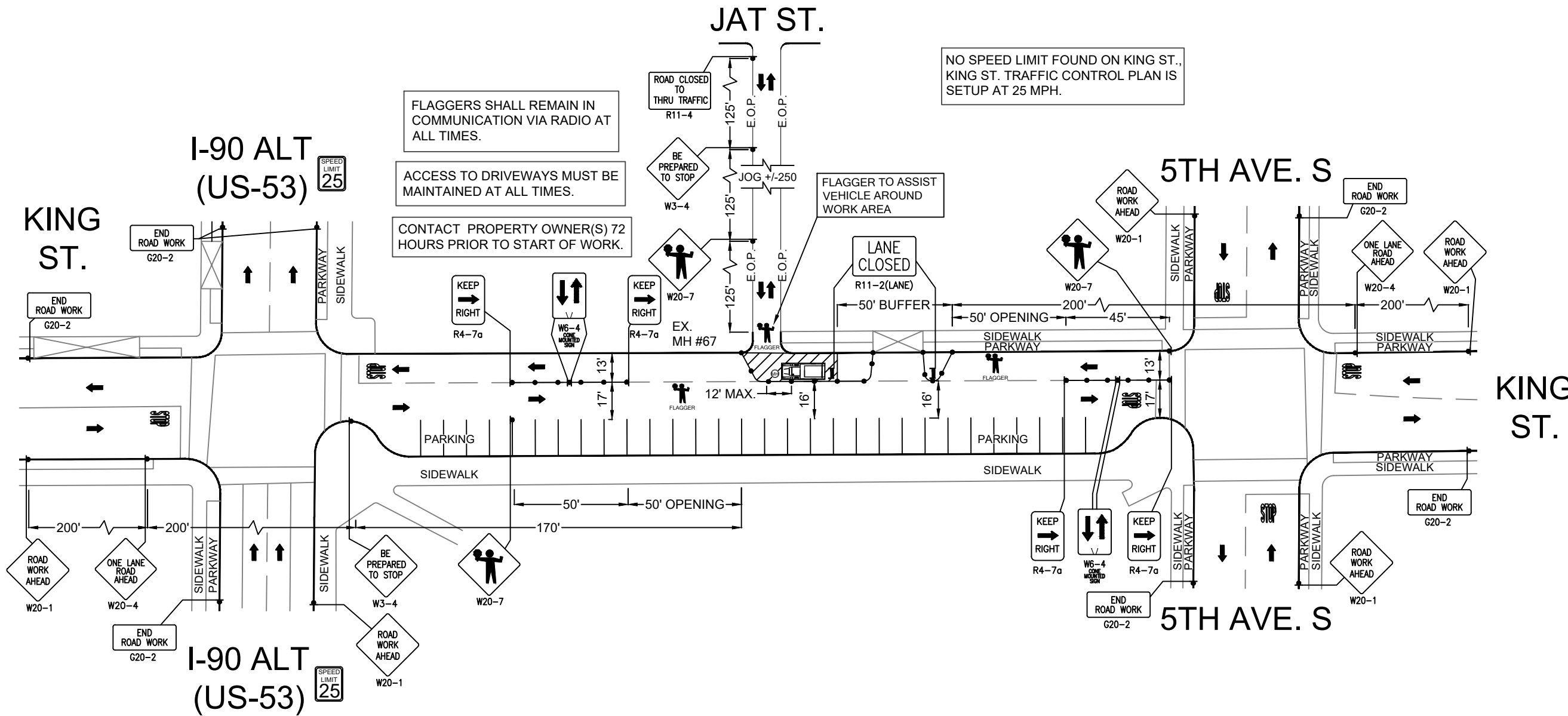

LEGEND

- * PORTABLE FLASHING BEACON (P.F.B.)
- ≡ TYPE III BARRICADE W/SIGN
- ≡ TYPE II BARRICADE W/SIGN
- CHANNELIZING DEVICE
- ▼ TRAFFIC CONE WITH CLIP ON SIGN
- TYPE I W/ SIGN
- EXISTING SIGN
- ⊙ SIGNALIZED INTERSECTION
- ⊞ FLASHING ARROW BOARD
- ⚡ HIGH LEVEL WARNING DEVICE (FLAGTREE)
- ♠ FLAGGER
- TANSAT TOW AWAY NO STOPPING ANY TIME
- ⊞ EXISTING DRIVEWAY
- ▨ WORK ZONE (ACTIVITY AREA) LIMITS
- DIRECTION OF TRAFFIC (NOT PAVEMENT MARKING)

CALL 811 BEFORE YOU DIG.
 WISCONSIN TOLL FREE
 800-242-8511

BRIGHTSPEED

PLANS PREPARED BY:
XCHC
 A CONGRUEX COMPANY
 9095 Rio San Diego Dr. Ste 165
 San Diego, CA 92108-1694
 (949) 250-0004 / FAX (949) 250-0006

REVISIONS

REV.	DESCRIPTION	BY	DATE
0	INITIAL DESIGN	V.D.	2/20/24

BRIGHTSPEED
 CONFIDENTIAL AND PROPRIETARY
 LCRSWIXC

TC-42 OF TC-44

SCALE: 1:50

**520 KING ST.
KING ST. & 5TH AVE. S
MH #72 ACCESS
WORK AREA 43 OF 44**

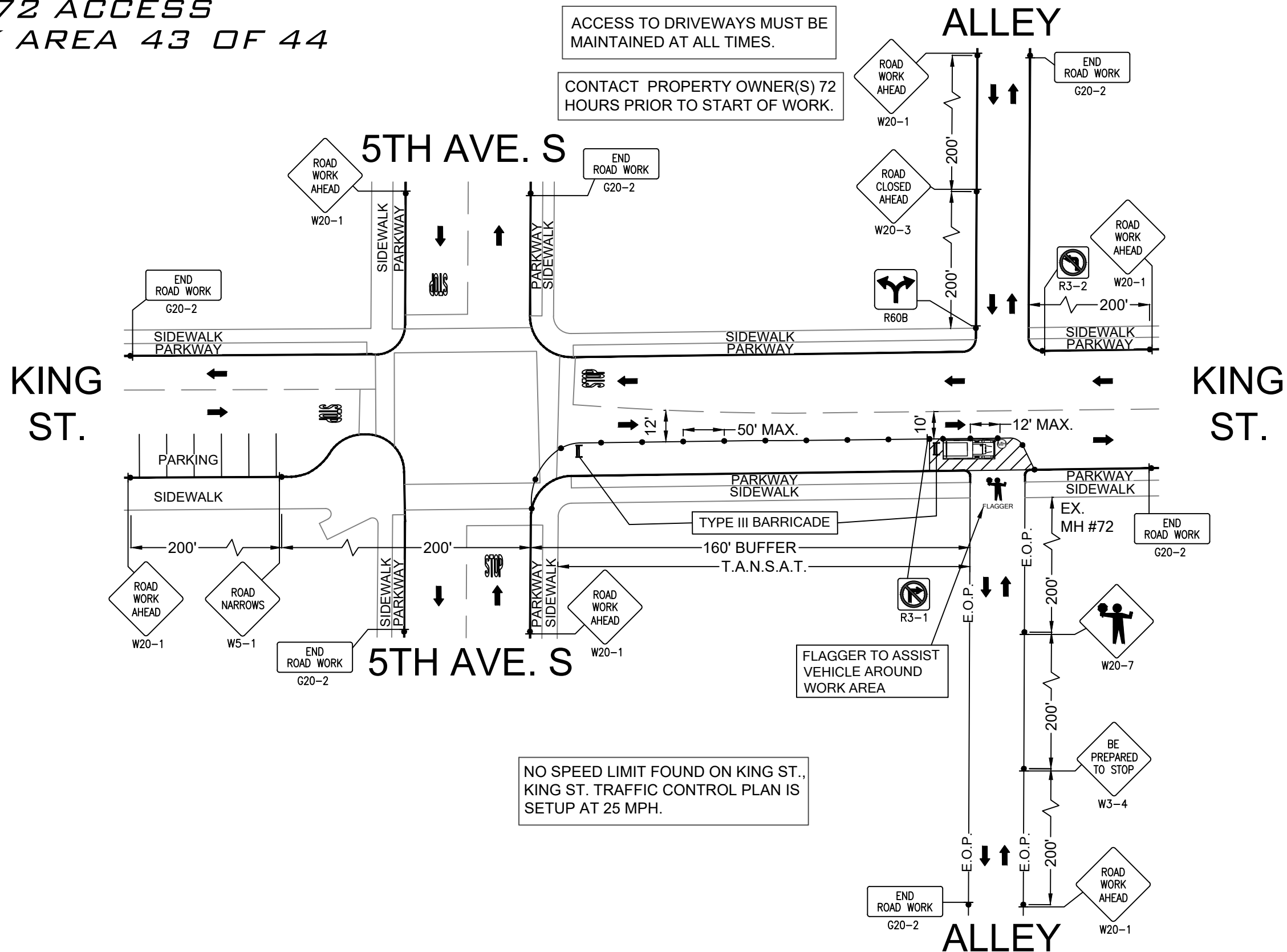

ACCESS TO DRIVEWAYS MUST BE MAINTAINED AT ALL TIMES.
CONTACT PROPERTY OWNER(S) 72 HOURS PRIOR TO START OF WORK.

NO SPEED LIMIT FOUND ON KING ST., KING ST. TRAFFIC CONTROL PLAN IS SETUP AT 25 MPH.

LEGEND

- * PORTABLE FLASHING BEACON (P.F.B.)
- ≡ TYPE III BARRICADE W/SIGN
- ≡ TYPE II BARRICADE W/SIGN
- CHANNELIZING DEVICE
- ▼ TRAFFIC CONE WITH CLIP ON SIGN
- TYPE I W/ SIGN
- EXISTING SIGN
- ⊙ SIGNALIZED INTERSECTION
- ⊞ FLASHING ARROW BOARD
- ⚡ HIGH LEVEL WARNING DEVICE (FLAGTREE)
- ♠ FLAGGER
- TANSAT TOW AWAY NO STOPPING ANY TIME
- ⊞ EXISTING DRIVEWAY
- ▨ WORK ZONE (ACTIVITY AREA) LIMITS
- DIRECTION OF TRAFFIC (NOT PAVEMENT MARKING)

CALL 811 BEFORE YOU DIG.
WISCONSIN TOLL FREE
800-242-8511

BRIGHTSPEED

PLANS PREPARED BY:
XCHC
A CONGRUEX COMPANY
9095 Rio San Diego Dr. Ste 165
San Diego, CA 92108-1694
(949) 250-0004 / FAX (949) 250-0006

REVISIONS

REV.	DESCRIPTION	BY	DATE
0	INITIAL DESIGN	V.D.	2/20/24

BRIGHTSPEED
CONFIDENTIAL AND PROPRIETARY
LCRSWIXC

TC-43 OF TC-44

SCALE: 1:40

**614 KING ST.
KING ST. & 6TH AVE. S
MH #77 ACCESS
WORK AREA 44 OF 44**

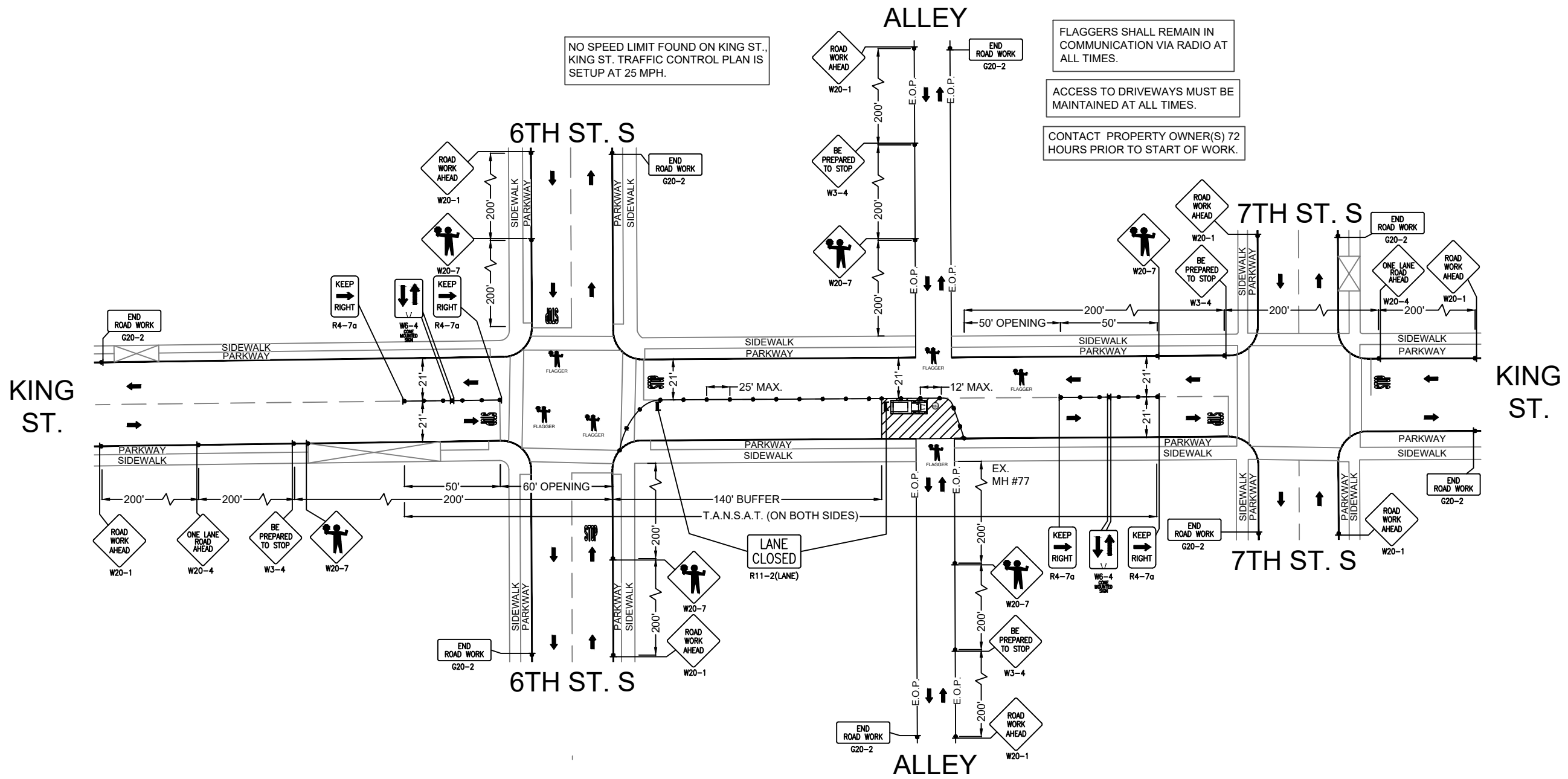

NO SPEED LIMIT FOUND ON KING ST., KING ST. TRAFFIC CONTROL PLAN IS SETUP AT 25 MPH.

FLAGGERS SHALL REMAIN IN COMMUNICATION VIA RADIO AT ALL TIMES.

ACCESS TO DRIVEWAYS MUST BE MAINTAINED AT ALL TIMES.

CONTACT PROPERTY OWNER(S) 72 HOURS PRIOR TO START OF WORK.

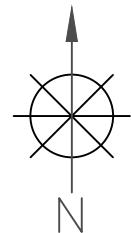

- LEGEND**
- * PORTABLE FLASHING BEACON (P.F.B.)
 - ≡ TYPE III BARRICADE W/SIGN
 - ≡ TYPE II BARRICADE W/SIGN
 - CHANNELIZING DEVICE
 - ▼ TRAFFIC CONE WITH CLIP ON SIGN
 - TYPE I W/ SIGN
 - EXISTING SIGN
 - ⊙ SIGNALIZED INTERSECTION
 - ⊞ FLASHING ARROW BOARD
 - ⚡ HIGH LEVEL WARNING DEVICE (FLAGTREE)
 - ♠ FLAGGER
 - TANSAT TOW AWAY NO STOPPING ANY TIME
 - ⊞ EXISTING DRIVEWAY
 - ▨ WORK ZONE (ACTIVITY AREA) LIMITS
 - DIRECTION OF TRAFFIC (NOT PAVEMENT MARKING)

CALL 811 BEFORE YOU DIG.
WISCONSIN TOLL FREE
800-242-8511

BRIGHTSPEED

PLANS PREPARED BY:
CHC
A CONGRUEX COMPANY
9095 Rio San Diego Dr. Ste 165
San Diego, CA 92108-1694
(949) 250-0004 / FAX (949) 250-0006

REVISIONS			
REV.	DESCRIPTION	BY	DATE
0	INITIAL DESIGN	V.D.	2/20/24

BRIGHTSPEED
CONFIDENTIAL AND PROPRIETARY
LCRSWIXC

TC-44 OF TC-44

SCALE: 1:60



City of La Crosse, Wisconsin

City Hall
400 La Crosse Street
La Crosse, WI 54601

Text File

File Number: 24-1553

Agenda Date: 12/9/2024

Version: 1

Status: Agenda Ready

In Control: Board of Public Works

File Type: General Item



TEMPORARY STREET PRIVILEGE PERMIT
 Engineering Dept. • Phone: (608) 789-7505 • Fax: (608) 789-8184
 http://www.cityoflacrosse.org engineering@cityoflacrosse.org

APPROVED

Permit No: <u>2024-084</u>
Date:
Parcel ID:

STATUS: _____	Permit Type: <u>TSP</u>
---------------	-------------------------

Name: <u>Brightspeed</u>			
Address: <u>1120 South Tryon St., Suite 700</u>			
City: <u>Charlotte</u>	State: <u>NC</u>	Zip Code: <u>28203</u>	
Phone:	Cell: <u>980-376-1808</u>	Fax:	Email:
Vehicle License Number (If Applicable):			Tag #:

Location: <u>900 KANE ST</u>					
Area to be occupied:	<input type="checkbox"/> Traffic Lane(s)	<input type="checkbox"/> Parking Lane(s)	<input type="checkbox"/> Boulevard	<input type="checkbox"/> Sidewalk	<input type="checkbox"/> Alley
Purpose for permit: <u>Access existing manholes and handholes to place 6,363 ft of conduit over existing conduit.</u>					
Additional Conditions:					

Start Date: <u>7/15/24</u>	End Date: <u>7/19/24</u>
----------------------------	--------------------------

Invoice #:	Fee: \$ _____ (\$35.00 first 5 days, \$2.00 each additional day)
Permit issued by:	
Comments: All work along Copeland Ave/Causeway Blvd. must be coordinated with the existing crews on site. The city contracted road project takes precedence over Brightspeed work. Contact can be made with Ryan Meiners at rmeiners@sehinc.com or his direct line 608-519-4553 Any signalized intersection with flaggers shall have notification given to the City of La Crosse Engineering Department minimum 24-hours in advance. The flagging operation at signalized intersections shall take place on weekdays only. Any highway lane closure, if applicable, shall be recorded with the WisDOT by a Brightspeed representative.	

The undersigned understands and agrees to the following: 1) The permitted work shall comply with all permit provisions and conditions listed on and attached to this form; 2) That insurance requirements shall be met prior to approval either by submitting information with application or by keeping current information on file with the Engineering Dept.; 3) The applicant shall contact City Dispatch and the City Traffic Engineer 24 hours prior to the closure of any traffic lanes and shall provide an estimate of the duration of the closure. Temporary traffic control shall be provided and maintained by the applicant and shall comply with Part 6 of the *Manual on Uniform Traffic Control Devices (MUTCD)*.

Note: Once invoiced, application fees may not be refunded. Details of permit, including dates, may be modified with approval of the Engineering Department.

Brittany Bruneau
 (PRINT) AUTHORIZED REPRESENTATIVE

Permit Specialist
 TITLE

 DATE

Brittany Bruneau
 (SIGN) AUTHORIZED REPRESENTATIVE

Permit Specialist
 TITLE

 DATE

BRIGHTSPEED LA CROSSE

LCRSWIXC
 900 KANE ST, LA CROSSE, WI 54603, USA
 CONDUIT LAYOUT

Sheet List Table

Sheet Number	Sheet Title
01	COVER SHEET
02	GENERAL NOTES
03	LEGENDS
04	TYPICAL
05-16	FIBER LAYOUTS

Material List Table

ITEM	QUANTITY
FEEDER FIBER	00
JUMPER	00
17"X30"X18" HH	00
12"X24"X18" HH	00
24"X36"X24" HH	00
2" CONDUIT	00
NEW STRAND	00
ANCHOR	00

BLM INFO

SECTION	S28, S32
MUNICIPALITY	LA CROSSE
TOWNSHIP	T16N
COUNTY	LA CROSSE
RANGE	R7W

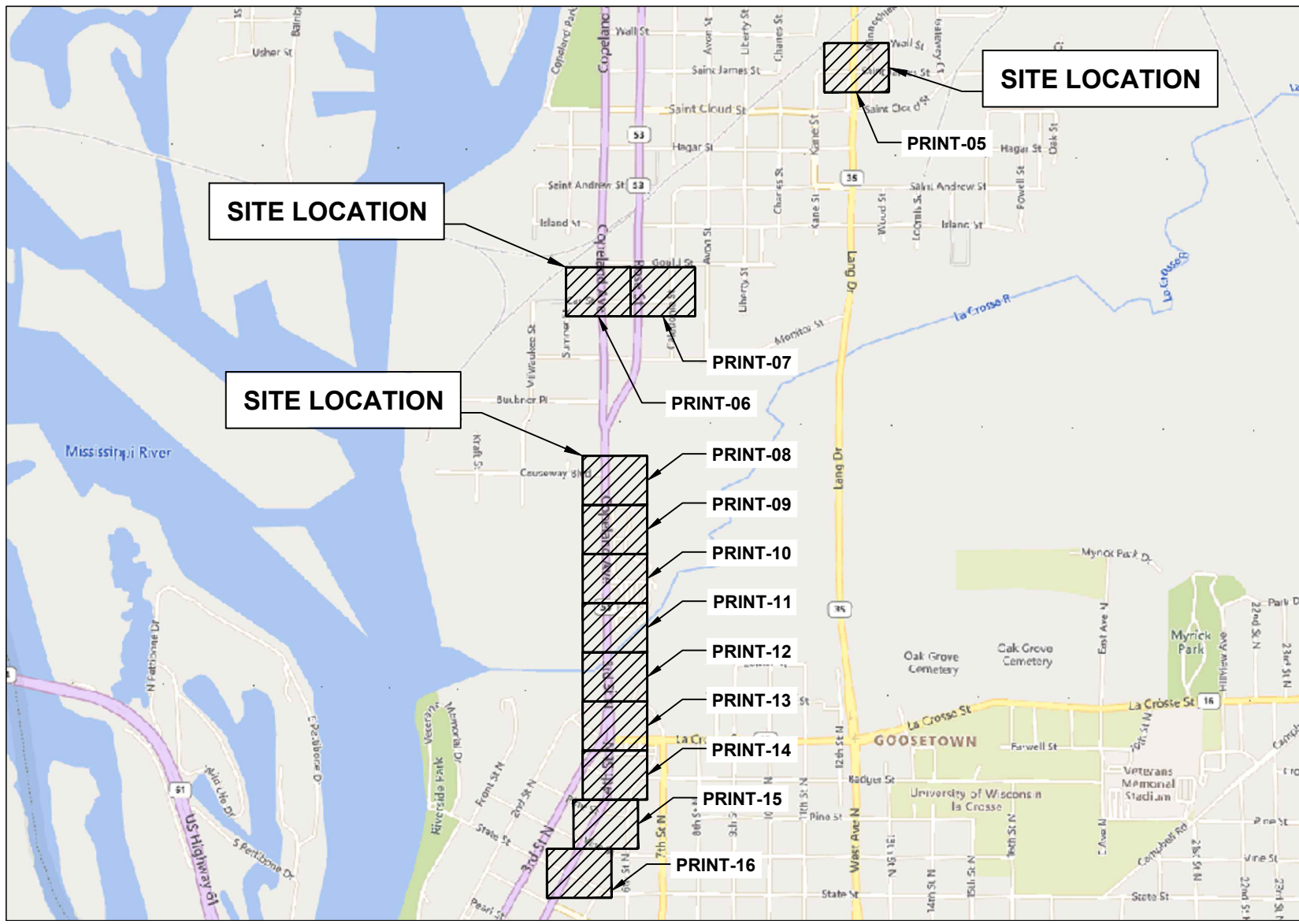

GENERAL ABBREVIATIONS

R/W	RIGHT OF WAY
S/W	SIDEWALK
C/L	CENTER LINE
CSW	CONCRETE SIDEWALK
DWY	DRIVEWAY
FOC	FACE OF CURB
BOC	BACK OF CURB
EOC	EDGE OF CURB
EOP	EDGE OF PAVEMENT
ETW	ETW LINE
HH	HANDHOLE
MH	MANHOLE
N.T.S.	NOT TO SCALE
CONC	CONCRETE
PED	PEDESTAL (UTILITY)
PVC	POLYVINYL CHLORIDE
P/L	PROPERTY LINE
RR	RAILROAD
SL	STREET LIGHT
W-BLDG	WALL TO BUILDING
W-P	WALL TO POLE
W-W	WALL TO WALL
U/E	UTILITY EASEMENT
SD	STORM DRAIN
TS	TRAFFIC SIGNAL

REVISION	DATE	DESCRIPTION

PERMITTING AGENCY
 CITY OF LA CROSSE

LINEAR PATH FOOTAGE
 UNDERGROUND PATH - 6,363 FT

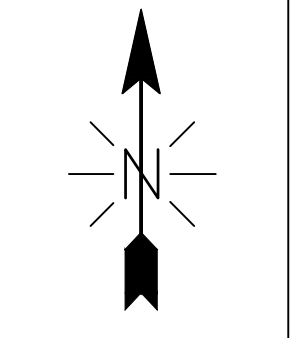

LCRSWIXC

COVER SHEET

PLAN SHEET DISCLAIMER:

1. EVERY REASONABLE EFFORT HAS BEEN MADE TO ASSURE THE ACCURACY OF THESE PLANS AND ASSOCIATED DATA.
2. IN AN EFFORT TO INCREASE THE CLARITY AND LEGIBILITY OF THE PLANS, EXISTING UNDERGROUND UTILITIES WILL NOT BE SHOWN UNLESS THERE IS PROPOSED WORK THAT WILL REQUIRE EXCAVATION OR ANY OTHER EARTH DISTURBING ACTIVITY. IF PROPOSED WORK WILL REQUIRE THIS TYPE OF ACTIVITY, EXISTING UNDERGROUND UTILITIES WILL BE PROPERLY INVESTIGATED AND REPRESENTED ON THE PLAN SHEET OF THE RESPECTIVE WORK LOCATION

UTILITIES

1. THE IDENTITY AND LOCATION OF EXISTING UNDERGROUND UTILITIES LOCATED IN AND AROUND THE CONSTRUCTION AREA HAVE BEEN SHOWN AND LABELED ON THE PLANS BY USING INFORMATION PROVIDED BY THE RESPECTIVE UTILITY OWNERS.
2. SUPPORT AND PROTECTION OF ALL UTILITIES AND APPURTENANCES SHALL BE THE RESPONSIBILITY OF THE CONTRACTOR. COSTS FOR THE REPAIR AND RESTORATION OF EXISTING UTILITIES DAMAGED BY THE CONTRACTOR SHALL BE THE RESPONSIBILITY OF THE CONTRACTOR
3. CALL 811 BEFORE YOU DIG. AT LEAST 48 HOURS PRIOR TO EXCAVATION.

WORK LIMITS

1. THE WORK LIMITS SHOWN ON THESE PLANS ARE FOR PHYSICAL CONSTRUCTION ONLY. THE INSTALLATION AND OPERATION OF ALL TEMPORARY TRAFFIC CONTROL AND TEMPORARY TRAFFIC CONTROL DEVICES REQUIRED BY THESE PLANS SHALL BE PROVIDED BY THE CONTRACTOR WHETHER INSIDE OR OUTSIDE OF THESE WORK LIMITS.

MAINTAIN DRAINAGE

1. THE CONTRACTOR AT HIS OWN EXPENSE, SHALL MAINTAIN THE FLOW IN ALL SEWERS, DRAINS, FIELD TILES, AND WATERCOURSES ENCOUNTERED IN AND AROUND THE PROJECT SITE. IF SUCH WATERCOURSES OR DRAINS ARE DISTURBED OR DESTROYED DURING THE EXECUTION OF THE PROJECT, THEY SHALL BE RESTORED BY THE CONTRACTOR AT HIS OWN EXPENSE TO A CONDITION SATISFACTORY TO THE ENGINEER.

SECURING EXCAVATIONS & TRENCHES FOR NON-WORKING HOURS

1. EXCAVATIONS AND TRENCHES OVER 24-INCHES DEEP SHALL BE SECURELY PLATED OR BACKFILLED DURING NON-WORKING HOURS.

EXCAVATION OF ROADWAY AND RIGHT-OF-WAY AREAS

1. ANY CONTRACTOR PERFORMING EXCAVATION, INCLUDING BUT NOT LIMITED TO DISTURBING THE EARTH WITH POWERED OR NON-POWERED EQUIPMENT, DRILLING AND/OR BORING, SHALL CAUSE NOTICE TO BE GIVEN BY CALLING 811 AT LEAST 48 HOURS BUT NOT MORE THAN 10 WORKING DAYS BEFORE EXCAVATING.
2. THE EXCAVATOR SHALL PROTECT AND PRESERVE THE MARKINGS UNTIL THOSE MARKINGS ARE NO LONGER NEEDED. IF AN EXCAVATION WILL COVER A LARGE AREA AND/OR PROGRESS FROM ONE AREA TO THE NEXT OVER A PERIOD OF TIME, THE EXCAVATOR SHALL COORDINATE THE MARKING OF APPROXIMATE LOCATIONS OF CITY OWNED FACILITIES WITH THE ACTUAL EXCAVATION.
3. THE CONTRACTOR IS RESPONSIBLE FOR LOCATING ALL CUSTOMER OWNED SERVICE LINES/LATERALS. THE CONTRACTOR SHALL FIELD VERIFY THE HORIZONTAL AND VERTICAL LOCATION OF ANY CITY OR CUSTOMER OWNED MAIN OR SERVICE LINE/LATERALS THAT MAY BE AFFECTED BY THE PROPOSED CONSTRUCTION ACTIVITIES. FIELD VERIFICATION SHALL TAKE PLACE PRIOR TO ANY ACTIVITY THAT MAY JEOPARDIZE THE INTEGRITY OF THE FACILITY AND AT A LOCATION NEAREST THE POINT OF POSSIBLE CONFLICT.
4. ANY DAMAGES TO CITY OR CUSTOMER OWNED FACILITIES SHOULD FIRST BE REPORTED TO THE UTILITY OWNER THEN IMMEDIATELY NOTIFY THE PROJECT ENGINEER.

AERIAL CONSTRUCTION:















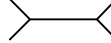































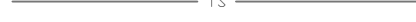

1. CONTRACTOR TO VERIFY ALL BONDING AND GROUNDING COMPLES WITH NESC GUIDELINES.
2. CONSTRUCTION TO VERIFY ALL REQUIRED MAKE READY WORK IS COMPLETE BEFORE PLACING ON UTILITY POLES.

SAFETY NOTE:

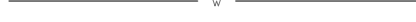



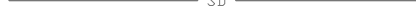
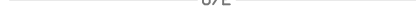



1. CHECK IN WITH CONSTRUCTION SUPERVISOR WHEN ARRIVING ON-SITE.
2. HEAVY CONSTRUCTION EQUIPMENT IN USE. BEWARE OF SURROUNDINGS.
3. FOLLOW CONGRUEX SAFETY POLICIES AND GUIDELINES AT ALL TIMES WHILE WORKING.
4. CONSTRUCTION ZONE/ HARD HAT, SAFETY GLASSES, REFLECTIVE VEST/SHIRT, SAFETY TOE BOOTS REQUIRED – WORK SAFELY

LEGENDS SHEET

EXISTING EQUIPMENTS LEGENDS

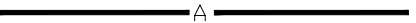
	R/W		CABINET		ELECTRIC TRANSFORMER		GAS METER		CULVERT
	CENTER LINE		EXISTING PED		ELECTRIC METER		GAS VALVE		C/L MONUMENT
	EOP		EXISTING FLOWERPOT		ELECTRIC VAULT/HANDHOLE		SEWER MANHOLE		ANCHOR & DOWN GUY
	BOC		EXISTING HANDHOLE		ELECTRIC MANHOLE		UNKNOWN MANHOLE		
	PROPERTY LINE		TELEPHONE CABINET		EXISTING VAULT		WATER METER		
	FENCE		TELEPHONE MANHOLE		STREETLIGHT		WATER VALVE		
	TELCO		POLE		POWER PED		FIRE HYDRANT		
	ELECTRIC		CABLE MARKER		CATV PED		WATER MANHOLE		
	GAS		STREET SIGN		CATV VAULT/HANDHOLE		STORM DRAIN CATCH BASIN		
	TRAFFIC SIGNAL		VERTICAL GROUND		TREE		STORM DRAIN MANHOLE		
	WATER		ELECTRIC PEDESTAL/CABINET		TRANSFORMER				
	SEWER								
	STORM DRAIN								
	UTILITY EASEMENT								
	RAIL TRACKS								
	SIDEWALK								

PROPOSED EQUIPMENTS LEGENDS

	BORE		12"X24"X18" HANDHOLE
	TRENCH		17"X30"X18" HANDHOLE
	AERIAL FIBER		24"X36"X24" HANDHOLE
	AERIAL STRAND		36"X48"X30" HANDHOLE
			ANCHOR & DOWN GUY

MINIMUM STANDARDS FOR DIRECTIONAL BORING
STREET CROSSINGS

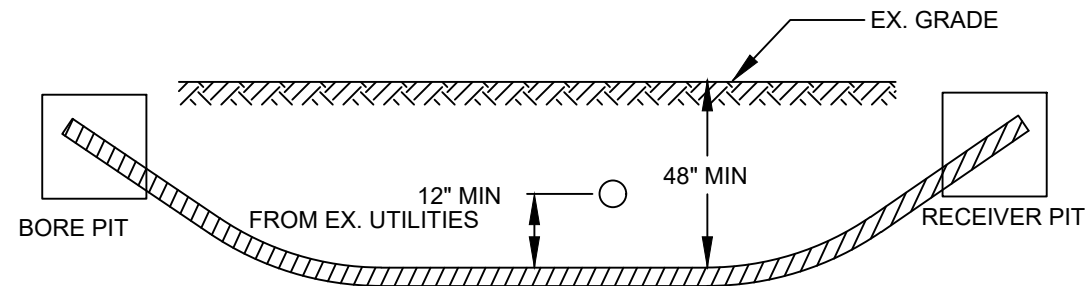

- PLACE END MARKER WITH UTILITY OWNER'S NAME DESCRIBING CONDUIT
- BORE PIT TO BE BACKFILLED AND COMPACTED IN 12" LIFTS WITH MATERIAL REMOVED
- FLOW OF DITCH MUST BE MAINTAINED AT ALL TIMES
- PROTECT ROOTS AT ALL TREE LOCATIONS, SHIFT BORE TRENCH IF NECESSARY

TYPICAL BORE DETAILS 1

MINIMUM STANDARDS FOR DIRECTIONAL BORING
UNDER SIDEWALKS & WITHIN ROW (EXCLUDING STREET CROSSINGS)

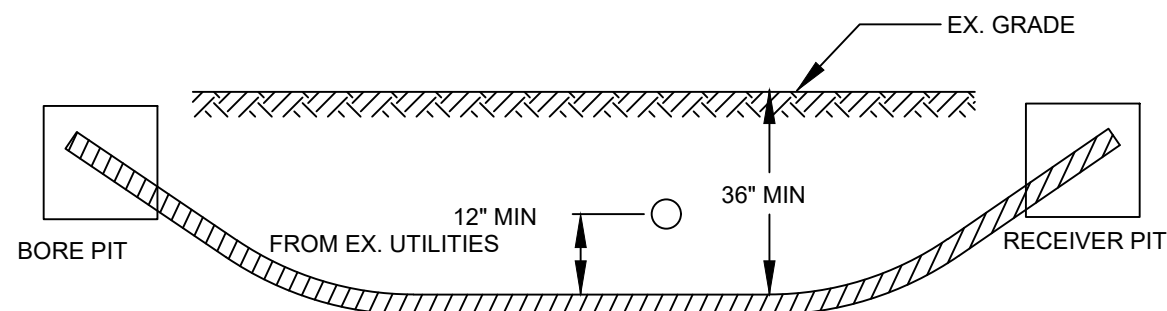

- PLACE END MARKER WITH UTILITY OWNER'S NAME DESCRIBING CONDUIT
- BORE PIT TO BE BACKFILLED AND COMPACTED IN 12" LIFTS WITH MATERIAL REMOVED
- FLOW OF DITCH MUST BE MAINTAINED AT ALL TIMES
- PROTECT ROOTS AT ALL TREE LOCATIONS, SHIFT BORE TRENCH IF NECESSARY

TYPICAL BORE DETAILS 2

PLAN VIEW

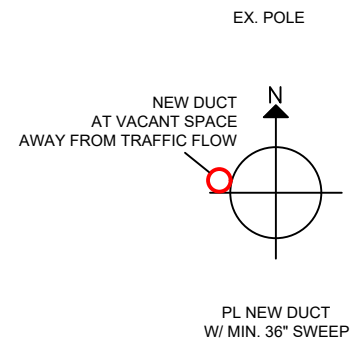

ELEVATION

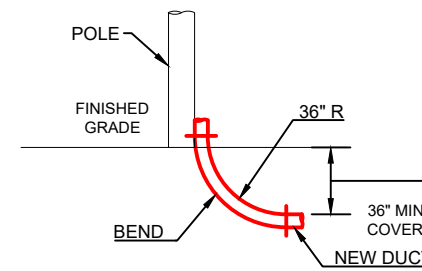

RISER DETAILS

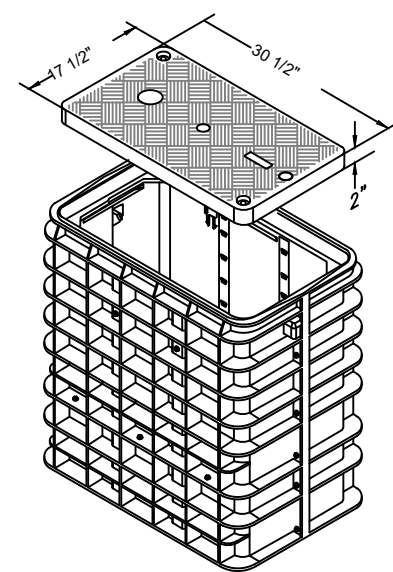

17"x30"x18"
N.T.S.

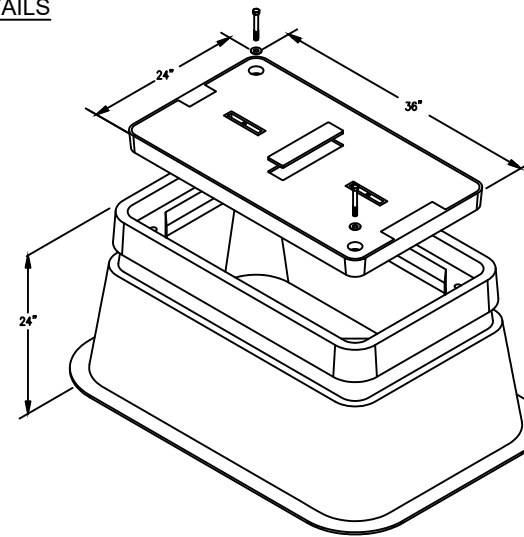

24"x36"x24"
N.T.S.

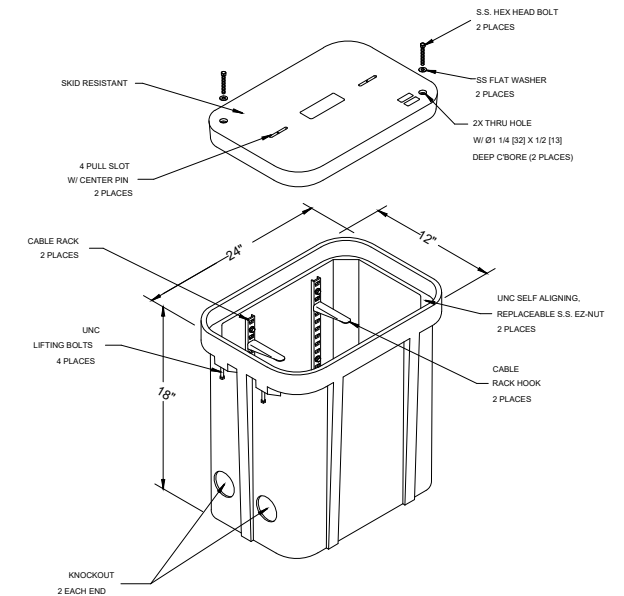

12"x24"x18"
N.T.S.

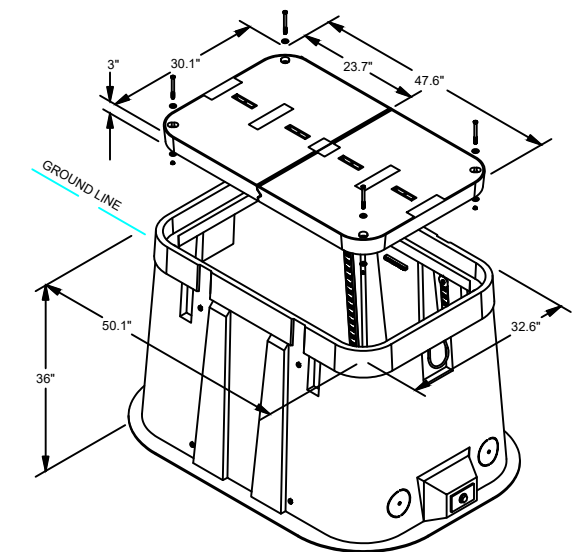

30"x48"x36"
N.T.S.

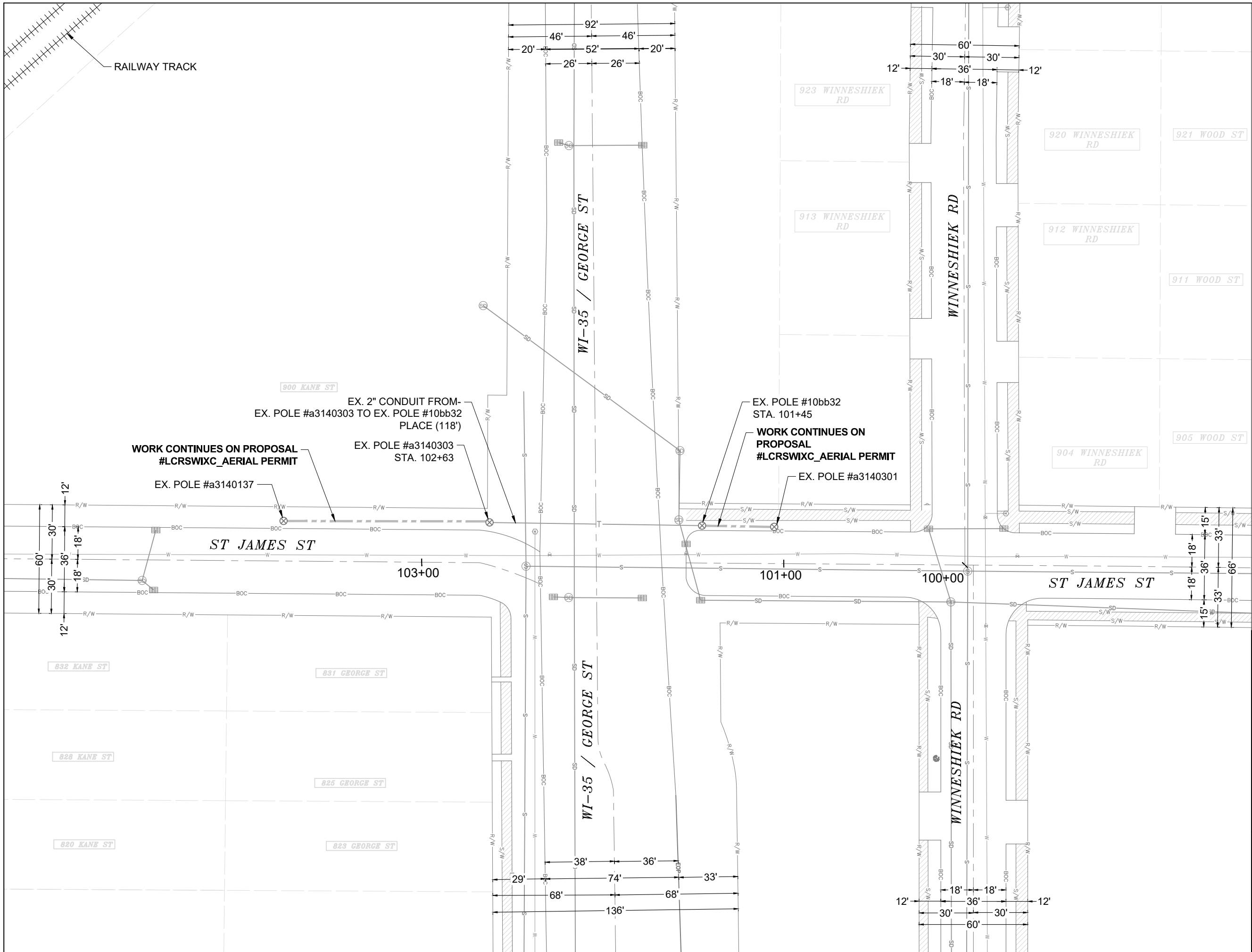

CALL 811 BEFORE YOU DIG.
WISCONSIN TOLL FREE
800-242-8511



CONFIDENTIAL AND PROPRIETARY
LCRSWIXC

05 OF 16

SCALE: 1" = 50'

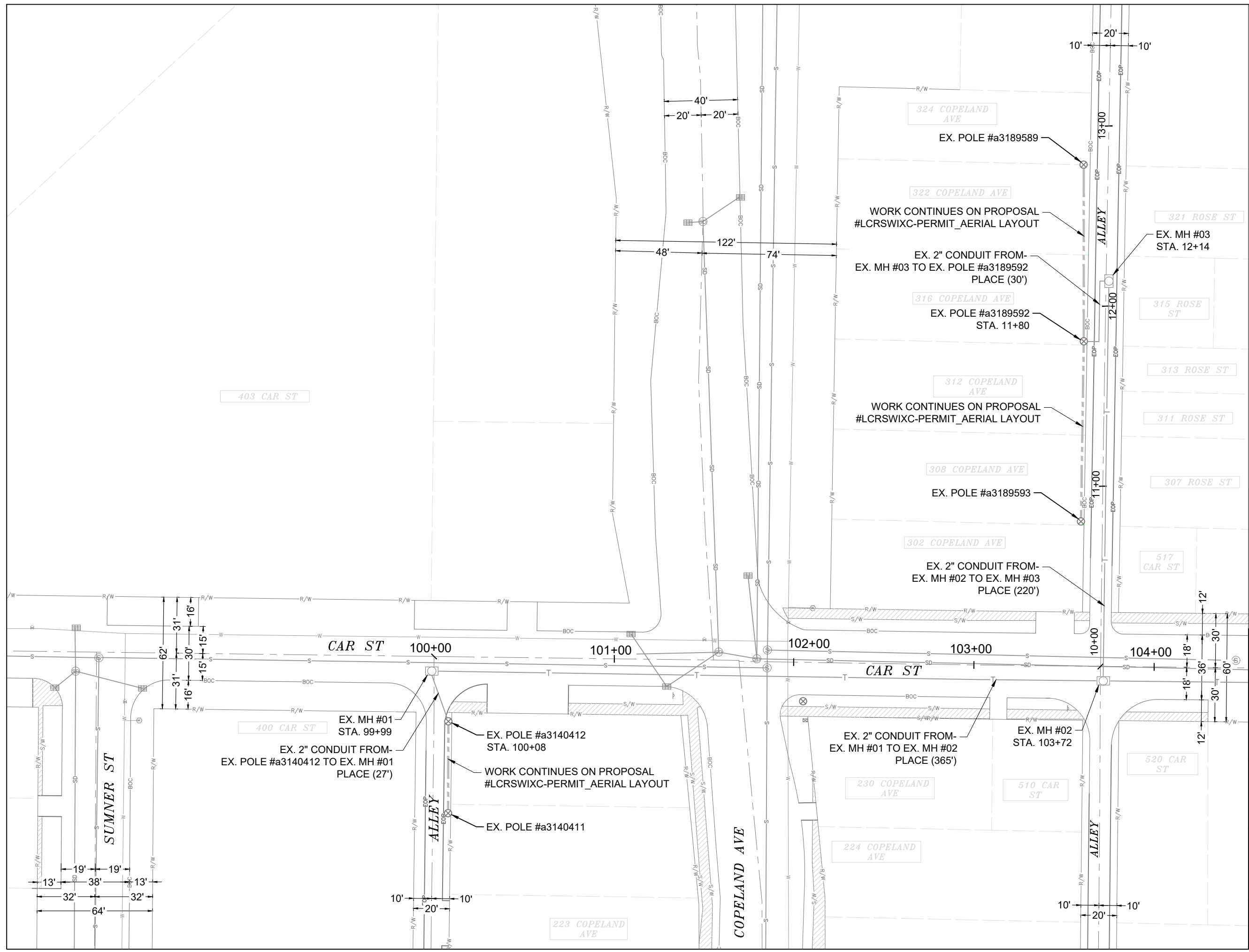
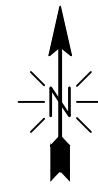

MATCH TO SHEET 07

CALL 811 BEFORE YOU DIG.
WISCONSIN TOLL FREE
800-242-8511



CONFIDENTIAL AND PROPRIETARY
LCRSWIXC

06 OF 16

SCALE: 1" = 50'

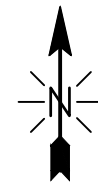

MATCH TO SHEET 06

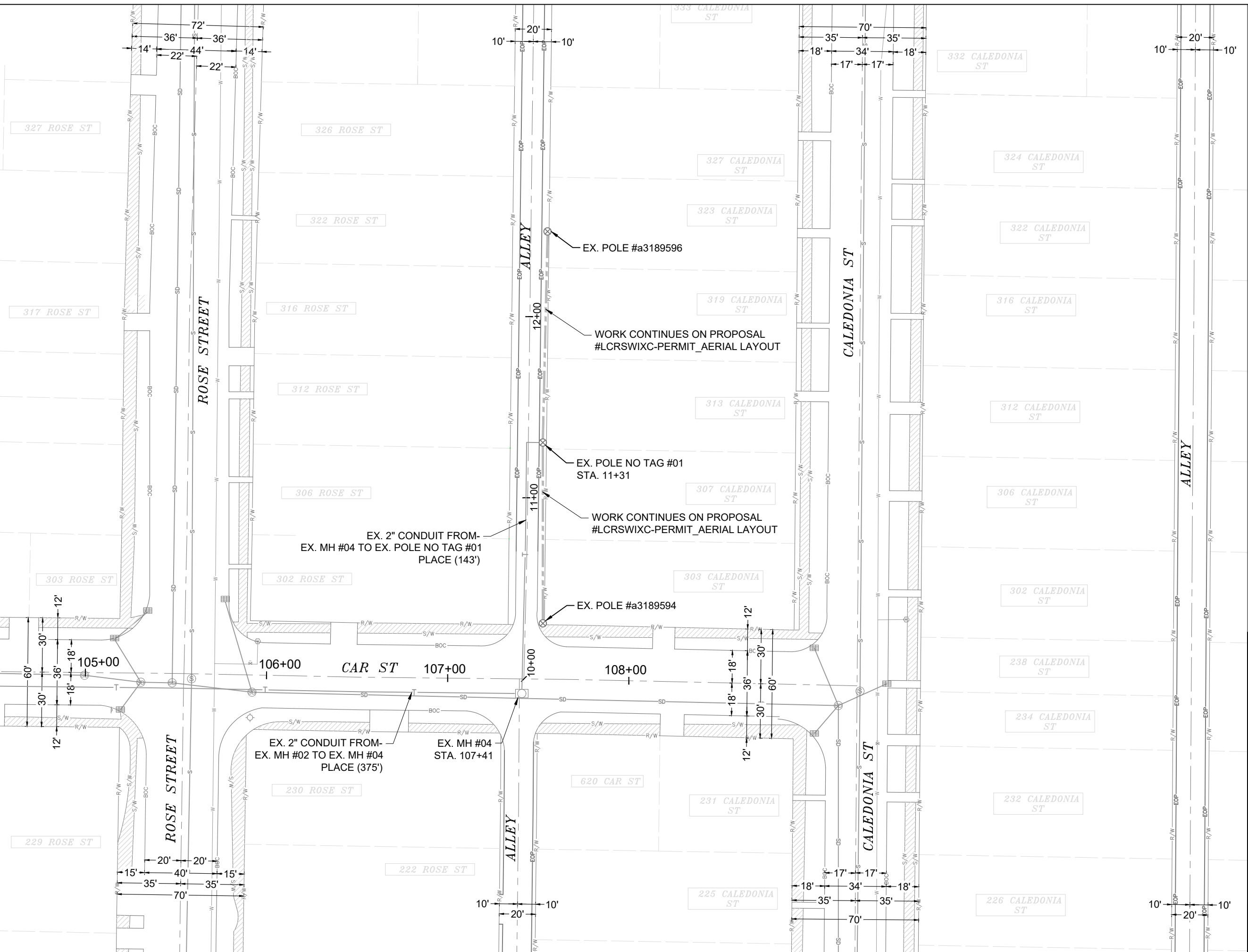

CALL 811 BEFORE YOU DIG.
 WISCONSIN TOLL FREE
 800-242-8511



CONFIDENTIAL AND PROPRIETARY
 LCRSWIXC

07 OF 16
 SCALE: 1" = 50'

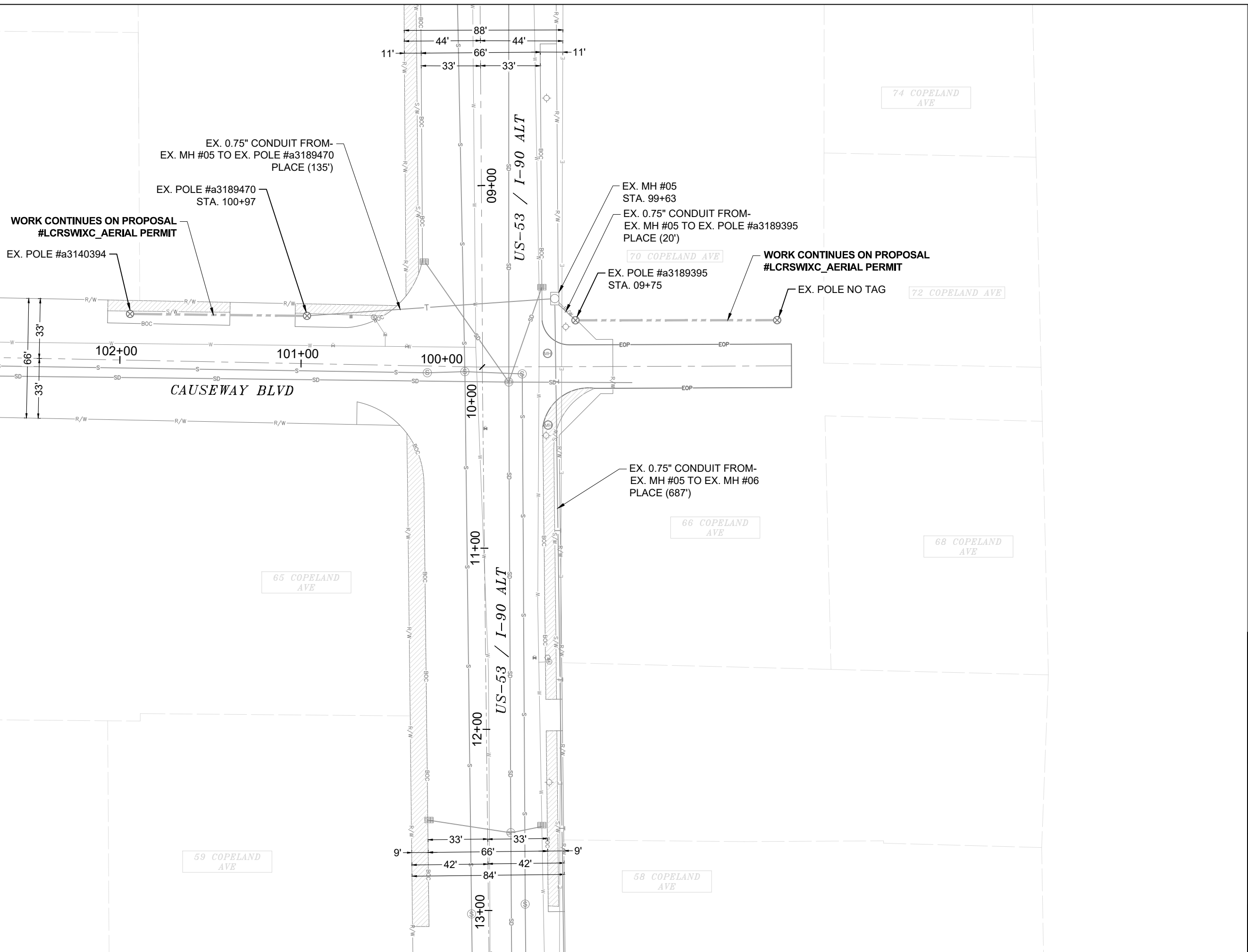
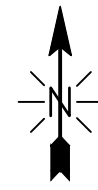

MATCH TO SHEET 09

CALL 811 BEFORE YOU DIG.
WISCONSIN TOLL FREE
800-242-8511



CONFIDENTIAL AND PROPRIETARY
LCRSWIXC

08 OF 16
SCALE: 1" = 50'

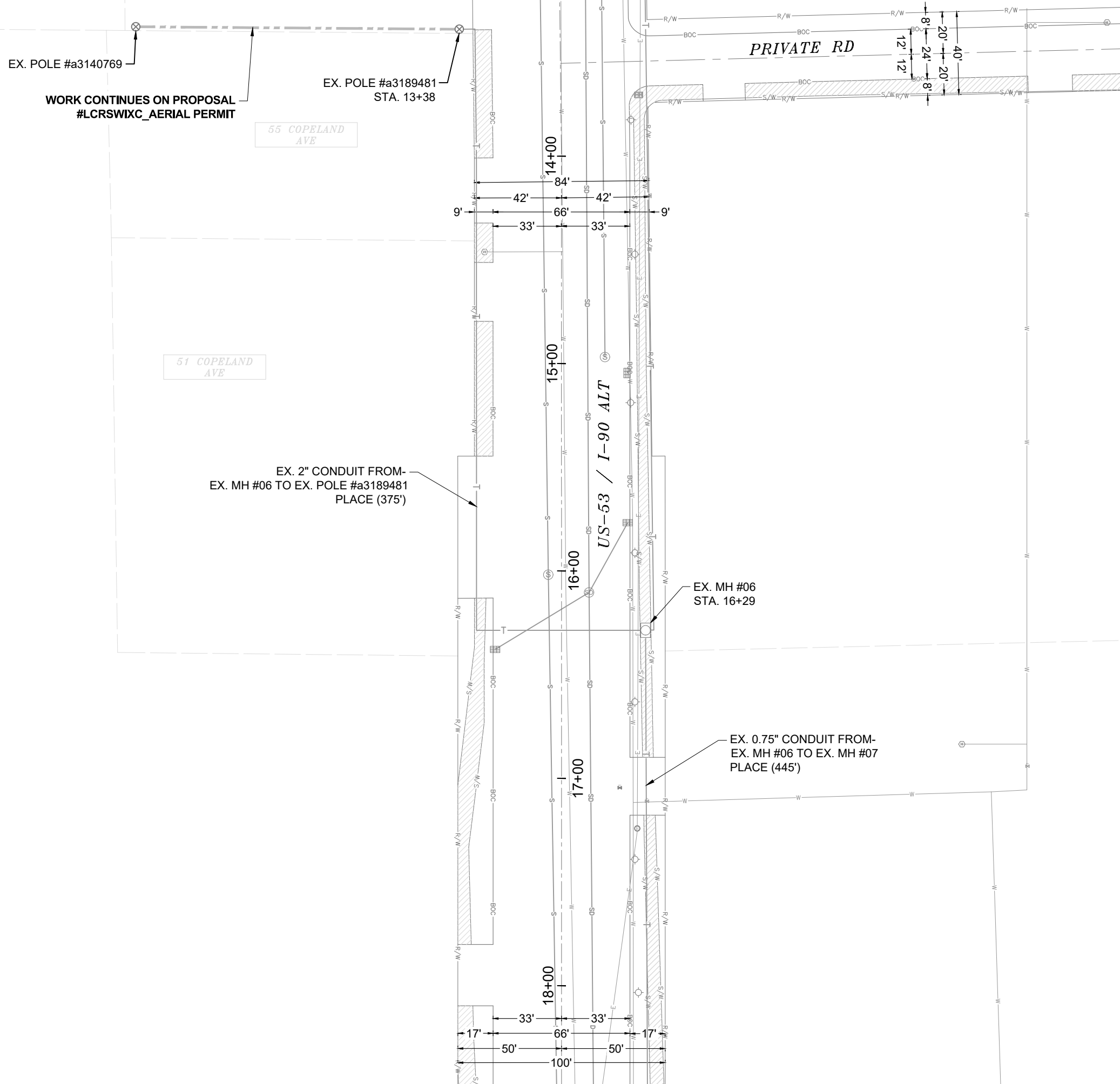

EX. POLE #a3140769

WORK CONTINUES ON PROPOSAL
#LCRSWIXC_AERIAL PERMIT

EX. POLE #a3189481
STA. 13+38

55 COPELAND
AVE

51 COPELAND
AVE

EX. 2" CONDUIT FROM-
EX. MH #06 TO EX. POLE #a3189481
PLACE (375')

EX. MH #06
STA. 16+29

EX. 0.75" CONDUIT FROM-
EX. MH #06 TO EX. MH #07
PLACE (445')

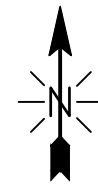

CALL 811 BEFORE YOU DIG.
WISCONSIN TOLL FREE
800-242-8511



CONFIDENTIAL AND PROPRIETARY
LCRSWIXC

09 OF 16
SCALE: 1" = 50'

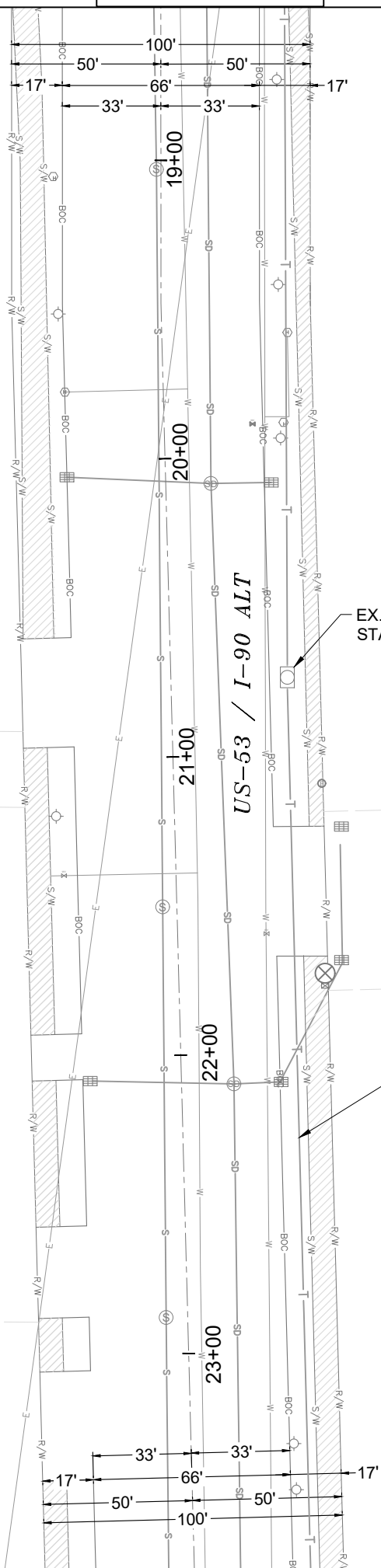
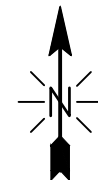

EX. MH #07
STA. 20+74

EX. 0.75" CONDUIT FROM-
EX. MH #07 TO EX. MH #08
PLACE (496')

CALL 811 BEFORE YOU DIG.
WISCONSIN TOLL FREE
800-242-8511



CONFIDENTIAL AND PROPRIETARY
LCRSWIXC

10 OF 16

SCALE: 1" = 50'

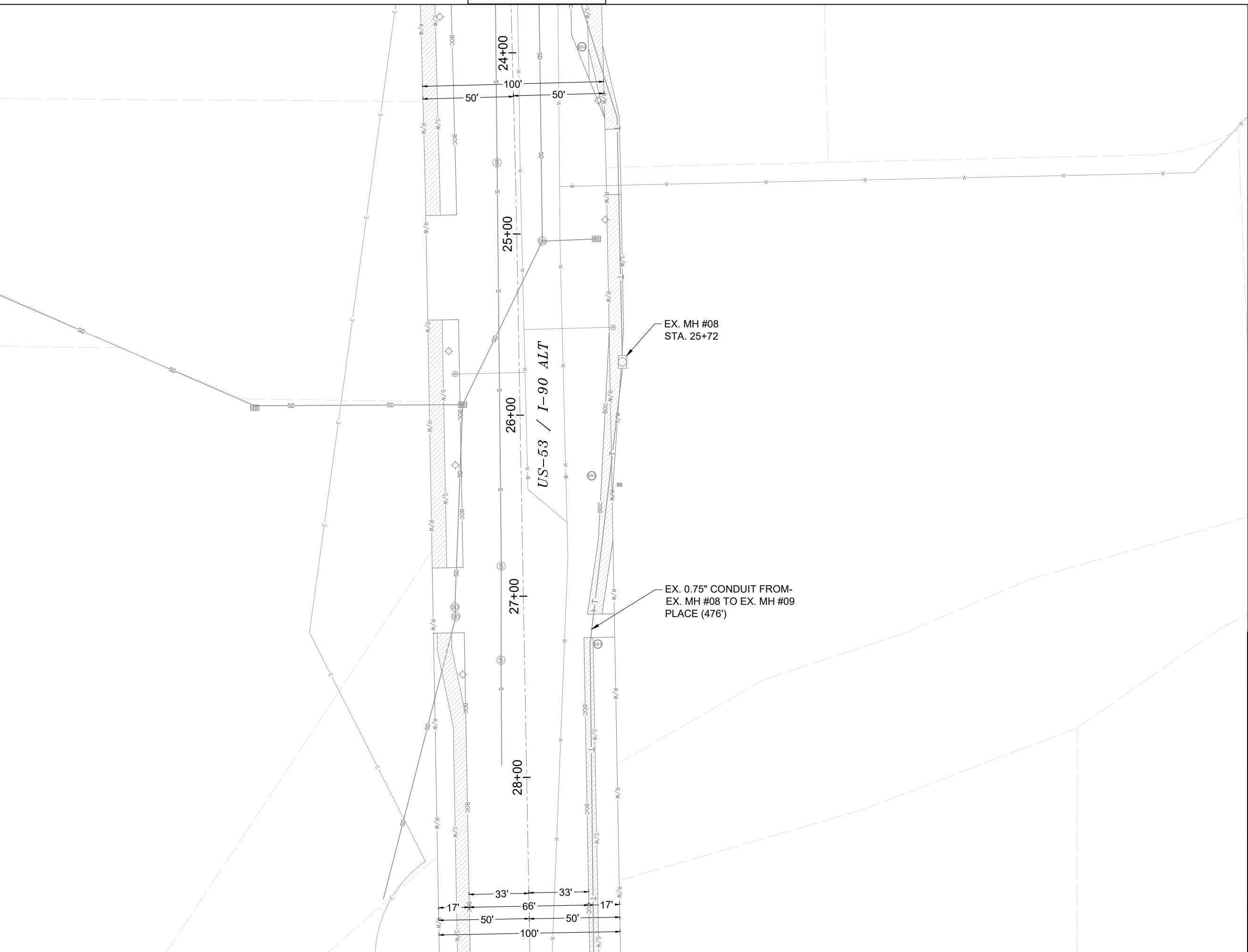

CALL 811 BEFORE YOU DIG.
 WISCONSIN TOLL FREE
 800-242-8511



CONFIDENTIAL AND PROPRIETARY
 LCRSWIXC

11 OF 16
 SCALE: 1" = 50'

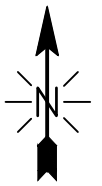

MATCH TO SHEET 11

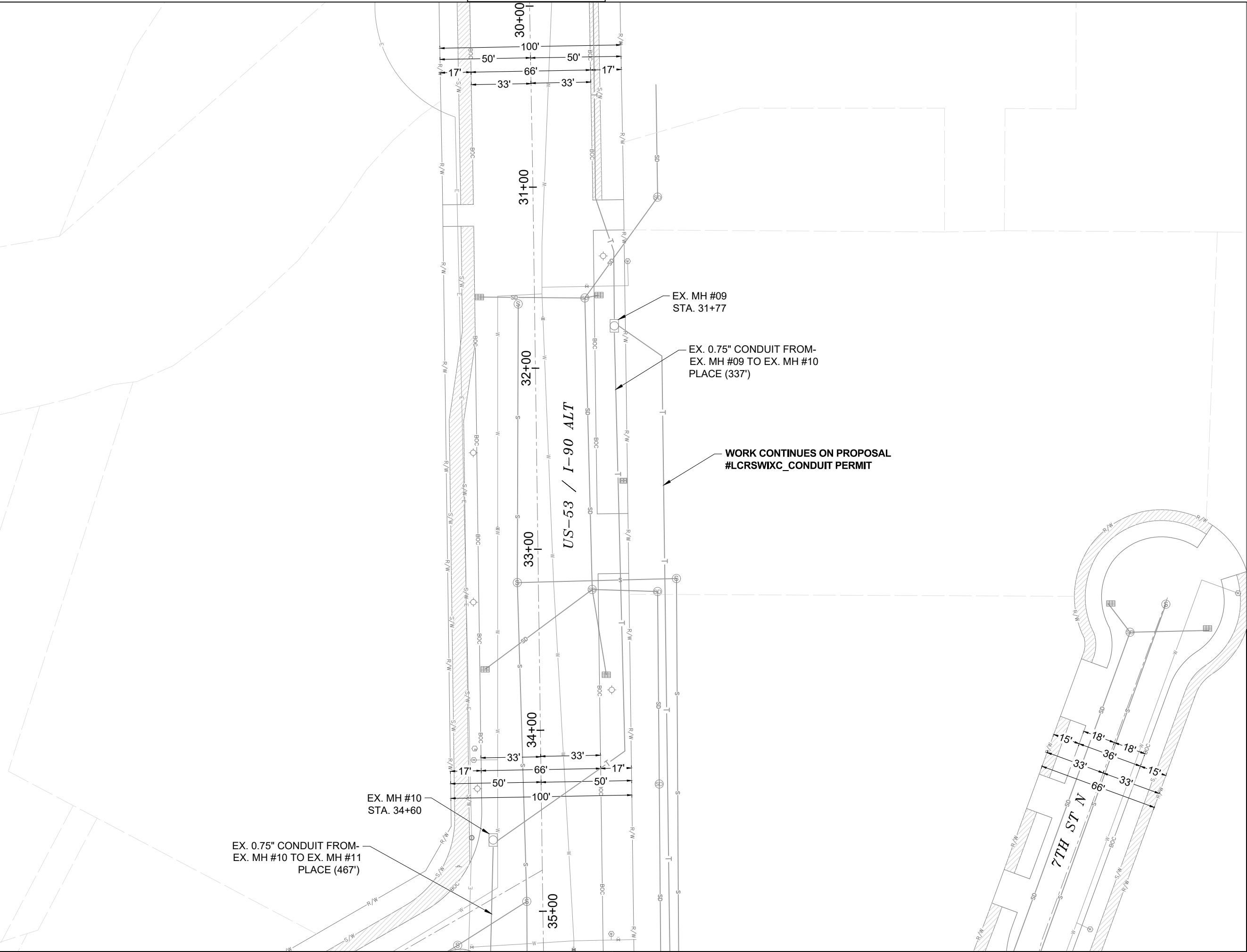

MATCH TO SHEET 13

CALL 811 BEFORE YOU DIG.
WISCONSIN TOLL FREE
800-242-8511



CONFIDENTIAL AND PROPRIETARY
LCRSWIXC

12 OF 16

SCALE: 1" = 50'

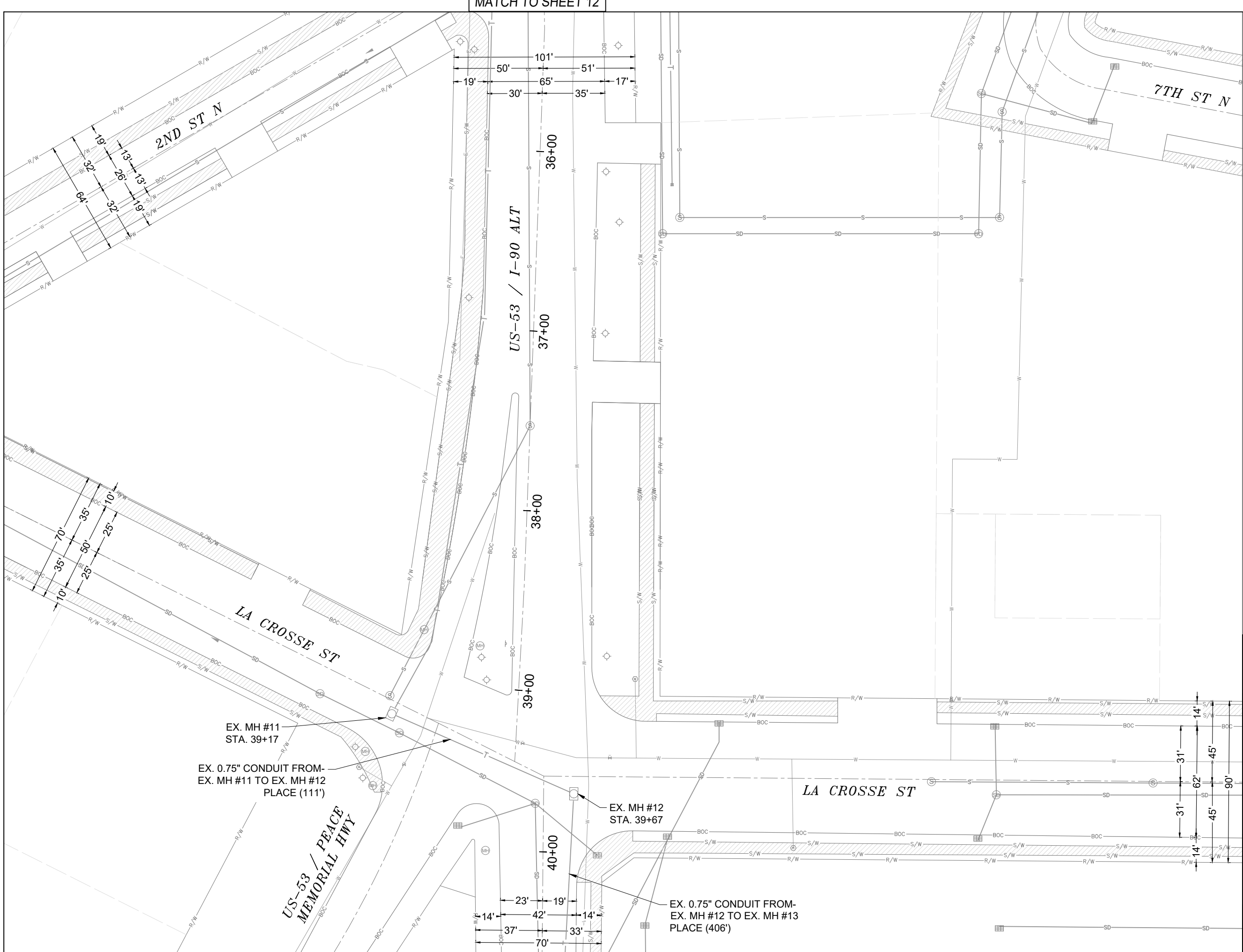
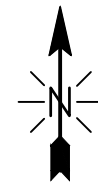

CALL 811 BEFORE YOU DIG.
 WISCONSIN TOLL FREE
 800-242-8511



CONFIDENTIAL AND PROPRIETARY
 LCRSWIXC

13 OF 16
 SCALE: 1" = 50'

MATCH TO SHEET 12

MATCH TO SHEET 14

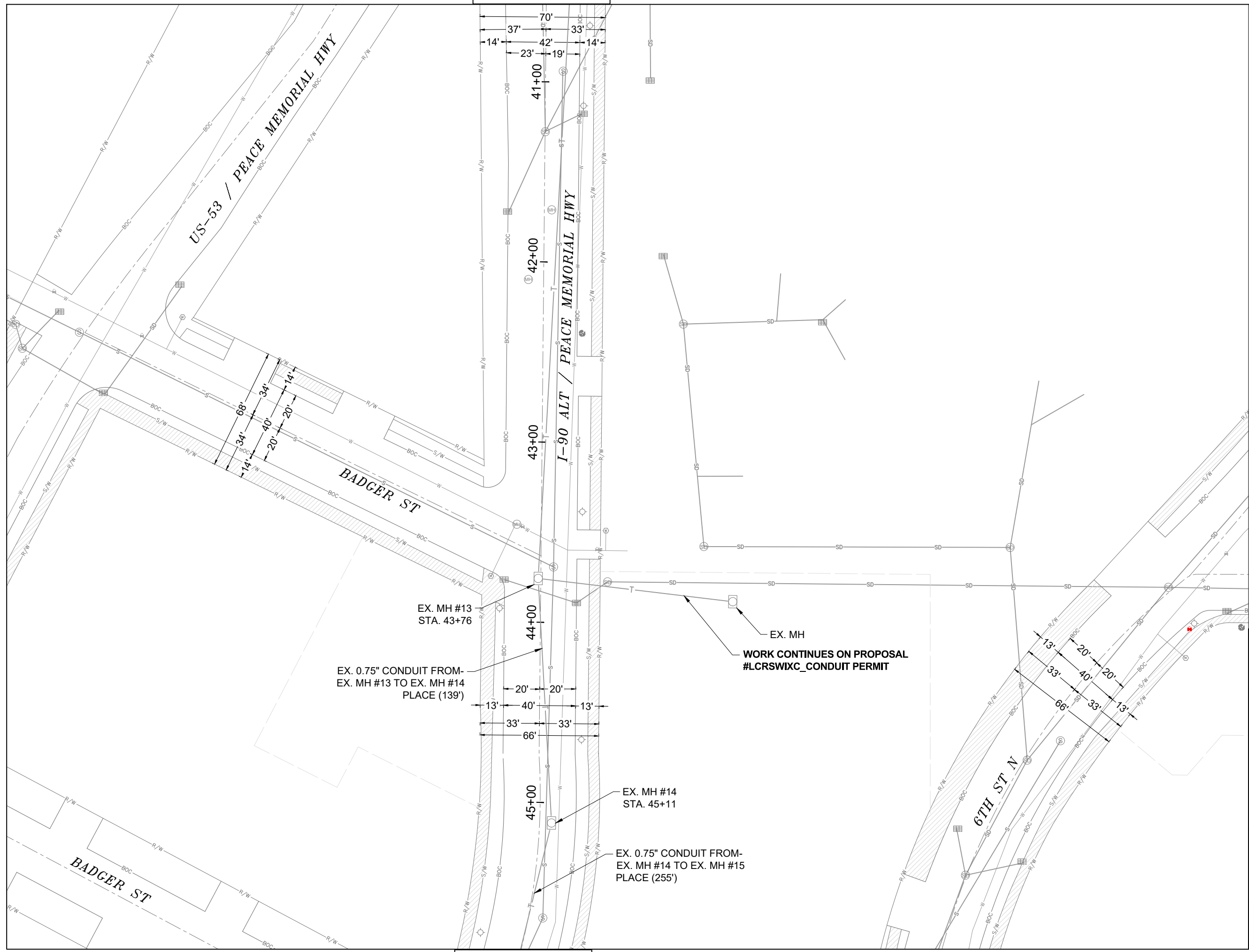
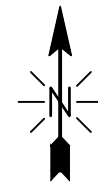

EX. MH #13
STA. 43+76

EX. 0.75" CONDUIT FROM-
EX. MH #13 TO EX. MH #14
PLACE (139')

EX. MH #14
STA. 45+11

EX. 0.75" CONDUIT FROM-
EX. MH #14 TO EX. MH #15
PLACE (255')

EX. MH
**WORK CONTINUES ON PROPOSAL
#LCRSWIXC_CONDUIT PERMIT**

CALL 811 BEFORE YOU DIG.
WISCONSIN TOLL FREE
800-242-8511



CONFIDENTIAL AND PROPRIETARY
LCRSWIXC

14 OF 16

SCALE: 1" = 50'

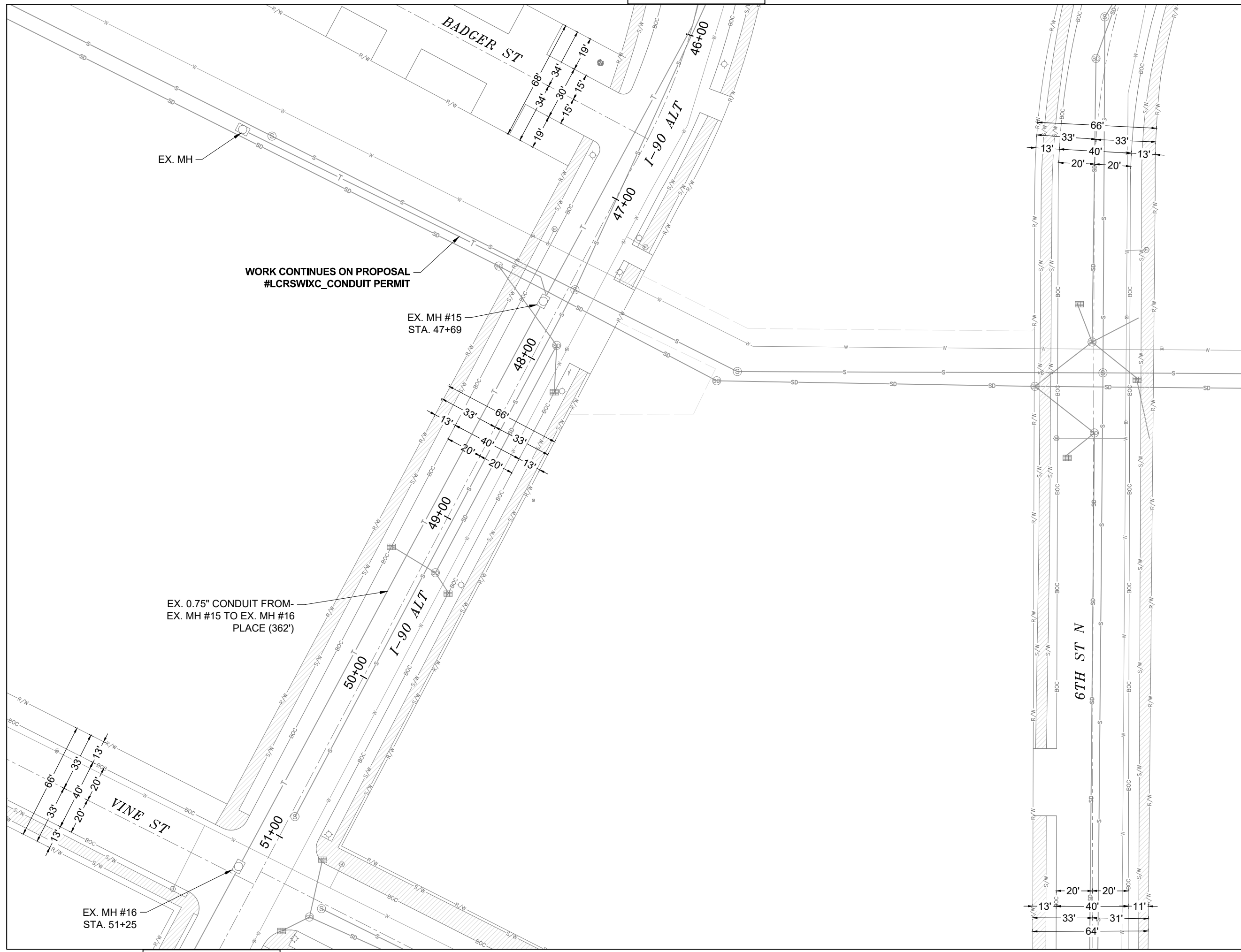
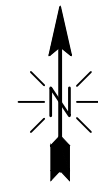

CALL 811 BEFORE YOU DIG.
 WISCONSIN TOLL FREE
 800-242-8511



CONFIDENTIAL AND PROPRIETARY
 LCRSWIXC

15 OF 16
 SCALE: 1" = 50'

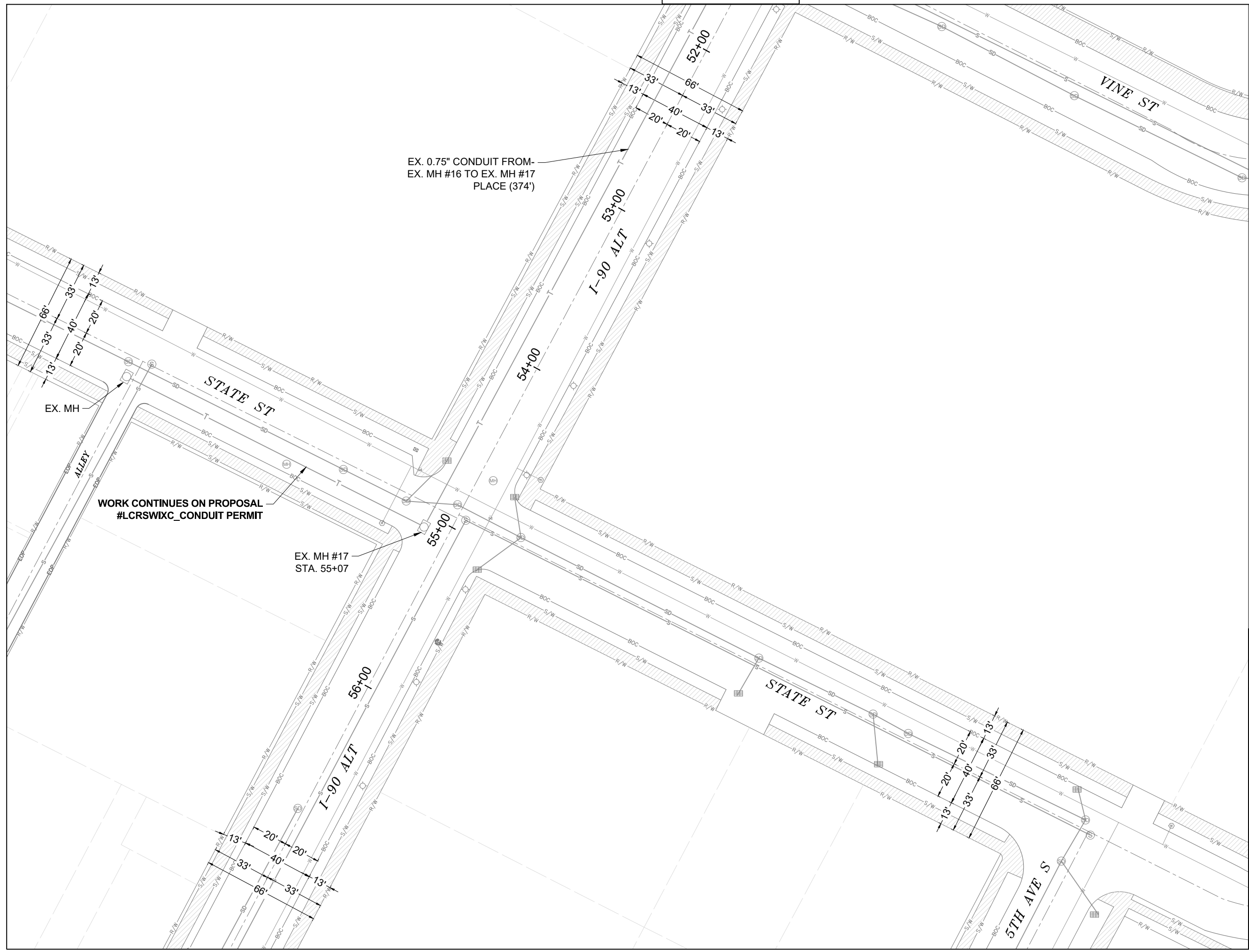

CALL 811 BEFORE YOU DIG.
WISCONSIN TOLL FREE
800-242-8511



CONFIDENTIAL AND PROPRIETARY
LCRSWIXC

16 OF 16
SCALE: 1" = 50'



City of La Crosse, Wisconsin

City Hall
400 La Crosse Street
La Crosse, WI 54601

Text File

File Number: 24-1556

Agenda Date: 12/9/2024

Version: 1

Status: Agenda Ready

In Control: Board of Public Works

File Type: General Item

2024 Standard Specification Changes

Removal

010.3.2 clarified what constitutes flatwork

General Install

100.3(3) added information about subbase material & duty of care.

105.3.3 removed much of the language about trees

114.3(4) modified dowel bar sizes, added table for clarification

115.3(4) added information about base course duty of care.

115.3.2 Added concrete aprons section

115.5 added item numbers

120.3 (2) added PROWAG reference

120.3(4) added sidewalk shall be planar

120.3(5) clarified sidewalk thickness usage

120.3.2 directed to construction detail

120.5 modified items to be sidewalk instead of flatwork

121 Modified section heading

121.1(1), 121.2(1), 121.3(1), 121.4(1), 121.5 detectable warning surfaces (not truncated dome warning fields)

121.3(1) added PROWAG reference

121.3 modified to direct to construction detail

121.4 redefined measurement section

122 Concrete Pedestrian Curb – New section, Item, construction detail

125.3(3) added information about curb & gutter within the corner radius

125.3.2, 125.3.3, 125.3.4, 125.3.5 modified to direct to construction detail

125.3.7(1) modified to standardize jointing requirements

130.3(2) added information about base course duty of care.

130.3.1 added Base Depth to Asphalt table

130.3.4 removed much of the language about trees

135 City of La Crosse Retaining Wall – New section added

Storm Sewer

200.3.3 removed much of the language about trees

205.2(1) added alternative pipe option

205.2.2(2) added depth of pipe usage

205.2.4 Removed section about Corrugated Polypropylene Pipe

205.2.5 removed section about High Density corrugated polyethylene pipe (HDPE)

205.5 removed new & replace items of Polypropylene & HDPE pipes

220.2(4) defined pipe connection length

220.2.2(8) added outside surface coating

220.2.4(9) added outside surface

220.2.6(1) added concentric top.

220.2.8(4) defined bolts to be stainless steel

220.2(7) insulation board removed

220.2.8 modified table of castings

220.3.5(1) removed mention of skim coating

- 220.3.5(7) inspection prior to placing casting.
- 220.3.6(1) added note about when replacement item should be used.
- 230..3.1(2) added more detail about using brick & mortar to seal the added pipe
- 230.3.2(4) defined bolts to be stainless steel
- 230.3.3(3) removed mention of skim coating
- 230.3.3(8) defined bolts to be stainless steel
- 230.3.5(5) defined bolts to be stainless steel
- 230.4(3) removed mention of skim coating

Water

- 400.3.4 removed much of the language about trees
- 402 & 602 Added new section insulation board
- 410.3.4 (4) added maximum size of live tap
- 420.2.1 added (3) minimum size
- 420.1 added SWDA reference
- 420.3 added information about transmission main & tapping allowance
- 420.3.1 (3) 2” or smaller connection type

Sanitary Sewer

- 600.3.3 removed much of the language about trees
- 620.2(6) added size of pipe for FERNCO boot
- 605.2.2(2) added depth of pipe usage
- 620.2.2(2) added Xypex add mixture to manholes
- 620.2(4) defined pipe connection length
- 620.2(7) Insulation board removed
- 620.2.3(1) removed exterior waterproofing sentence.
- 620.2.4(1) added additional information on base material
- 620.2.4(2) added when the outside drop should be used
- 620.2.6(1) added concentric top.
- 620.2.6(2) added Xypex add mixture
- 620.2.7(2) added Xypex add mixture
- 620.2.8 updated table of castings
- 620.3.5(1) removed mention of skim coating
- 625.3.1(2) added language requiring watertight seal
- 625.4(2) removed mention of skim coating

Streetscape/Lighting

- 800.3.3 removed much of the language about trees
- 815.3.2(9) add line about tracer wire for fiber conduit
- 820.2.2(2-6) moved to 820.2
- 830.3.1(1) modified to standardize with other removal items

Traffic

- 905.3.3 removed much of the language about trees
- 910.2.3(2) removed city provide anchor rods
- 910.2.4 added information about Type 10 Special base
- 910.3.7 & 8 added information about Type 10 special
- 915.2.1 added tracer wire information

925.2.4 & 5 added traffic signal lighting wire information
925.3.3 & 7 added signal lighting cable
925.3.5(8) clarified push button cabling
930.2.6 & 7 changed to Contractor furnish
930.2.6 added Type 9,10 Special poles
930.3.6 changed to Contractor furnish, added type 9, 10 Special
940.2.1, .2, .3 added color of housing to match color of the pole
940.2.3 modified to accessible pedestrian button
950.3.4, &5 removed Iteris and Autoscope information



Engineering Department

400 La Crosse St., La Crosse, WI 54601 • (608) 789-7505 • Fax: (608) 789-8184
<http://www.cityoflacrosse.org>

Appendix B:

City of La Crosse –

Standard Specifications and Procedures



Table of Contents

0. GENERAL REMOVALS..... 5

005-CONCRETE & BITUMINOUS SAWING.....5

010-CONCRETE REMOVALS6

015-BITUMINOUS REMOVALS.....8

020-TREE AND PLANTING REMOVALS10

1. GENERAL INSTALLATION..... 12

100-AGGREGATE MATERIALS12

105-GENERAL CONCRETE CONSTRUCTION13

110-STEEL REINFORCEMENT.....15

114-DRILLED TIE & DOWEL BARS.....16

115-CONCRETE PAVEMENT18

120-CONCRETE SIDEWALK20

121-DETECTABLE WARNING SURFACES22

122-CONCRETE PEDESTRIAN CURB23

125-CONCRETE CURB AND GUTTER25

130-BITUMINOUS CONCRETE27

135-CITY OF LA CROSSE RETAINING WALL29

140-EROSION CONTROL31

145-RESTORATION.....32

150-TEMPORARY TRAFFIC CONTROL.....34

155-CORE & POUR FINISHING35

2. STORM SEWER CONSTRUCTION 37

200-GENERAL STORM SEWER CONSTRUCTION37

201-EXCAVATION, BEDDING, & BACKFILL40

205-STORM SEWER PIPE43

220-STORM SEWER STRUCTURE CONSTRUCTION48

230-REPAIR/MODIFY EXISTING STORM SEWER STRUCTURE.....54

240-BIORETENTION CELLS (BIO-CELLS)57

4. WATER CONSTRUCTION 62

400-GENERAL WATER CONSTRUCTION62

401-EXCAVATION, BEDDING, & BACKFILL67

402-INSULATION BOARD WATER70

405-WATER MAIN.....71

410-VALVE & VALVE BOX74

415-HYDRANT CONSTRUCTION77

420-WATER SERVICE LATERAL79



Engineering Department

400 La Crosse St., La Crosse, WI 54601 • (608) 789-7505 • Fax: (608) 789-8184
http://www.cityoflacrosse.org

6. SANITARY SEWER CONSTRUCTION 82

600-GENERAL SANITARY SEWER CONSTRUCTION.....	82
601-EXCAVATION, BEDDING, & BACKFILL.....	84
602-INSULATION BOARD SANITARY.....	87
605-SANITARY SEWER PIPE.....	88
620-SANITARY SEWER STRUCTURE CONSTRUCTION.....	96
625-REPAIR/MODIFY EXISTING STRUCTURE.....	101
630-SEWER LINER (CIPP).....	103
635-REHABILITATE MANHOLE.....	116
640-BY-PASS PUMPING.....	123

8. STREETSAPING / LIGHTING 125

800-GENERAL LIGHTING CONSTRUCTION.....	125
805-EXCAVATION AND BACKFILL.....	129
810-LIGHTING BASES.....	131
815-LIGHTING CONDUIT.....	134
820-PULL BOXES.....	137
825-LIGHTING WIRING.....	139
830-POLES, ARMS, STANDARDS.....	141
835-LIGHTING CONTROL CABINET.....	143
850-BRICK PAVERS.....	145
860-CONCRETE EDGING.....	148
865-MULCH.....	149
870-INSTALL V-LOC SIGN SUPPORT.....	150
875-INSTALL NEW VALVE BOX TOP.....	151
880-SAW CUT V-SHAPE TOOL JOINT.....	152

9. TRAFFIC..... 154

900-CONCRETE MEDIAN.....	154
905-GENERAL SIGNAL CONSTRUCTION.....	156
906-EXCAVATION AND BACKFILL.....	161
910- SIGNAL BASES.....	163
915- SIGNAL CONDUIT.....	168
920- PULL BOX AND COMMUNICATION VAULT.....	171
925- SIGNAL WIRING.....	173
930- SIGNAL POLES, ARMS, STANDARDS.....	177
940- SIGNAL HEADS.....	182
945- SIGNAL CABINET EQUIPMENT.....	184
950- SIGNAL SPECIALTY EQUIPMENT.....	186
955-TEMPORARY SIGNAL.....	189
960-SIGNAL COMMUNICATION EQUIPMENT.....	191
970- PAVEMENT MARKING GENERAL.....	194
980- DELINEATOR POSTS.....	196



Engineering Department

400 La Crosse St., La Crosse, WI 54601 • (608) 789-7505 • Fax: (608) 789-8184
<http://www.cityoflacrosse.org>

0. GENERAL REMOVALS

- 005 CONCRETE & BITUMINOUS SAWING
- 010 CONCRETE REMOVALS
- 015 BITUMINOUS REMOVALS
- 020 TREE & PLANTING REMOVALS



0. GENERAL REMOVALS

005-CONCRETE & BITUMINOUS SAWING

005.1 General Description

- (1) This section describes the procedure for the sawing of bituminous and concrete within the City of La Crosse right of way.

005.2 Materials

- (1) Concrete will be of a composition in accordance with the general concrete construction within this document.
- (2) Steel reinforcement used within the concrete will be in accordance with general steel reinforcement within this document.
- (3) Bituminous will be of a composition in accordance with the general bituminous construction within this document.

005.3 Construction Methods

- (1) Equipment and tools necessary for performing all parts of the sawing work shall be satisfactory as to design, capacity, and mechanical condition for the purposes intended, and any equipment which is not maintained in full working order, or which as used by the Contractor is inadequate to obtain the results prescribed, shall be repaired, improved, replaced, or supplemented to obtain the progress and workmanship contemplated by the contract.
- (2) Sawing shall be full depth of material being cut and the face shall be generally vertical once cut.
- (3) All cuts shall be as per plan and/or straight between markings made by the engineer.
- (4) Sawing shall be done with water or a dry collection system following OSHA Standard 1926.1153.
- (5) The sludge from sawing shall be removed from the pavement upon completion of each saw cut by methods, which minimize the amount of sludge flowing onto or being deposited on the pavement of any live traffic lane.
- (6) All traffic control devices shall be cleaned of any sludge deposits by darkness of the day in which the deposition occurs.
- (7) This work shall be as shown on plans or by field marks made by the Engineer. Any sawing done outside of the plans or Engineer's markings will need to be sealed at the contractor's expense.
- (8) Sawing shall include the following but not limited to:
 - A. Labor and equipment to perform sawing work.
 - B. Tools for clean-up of sludge

005.4 Measurement

The department will measure Sawing by the Linear Foot (LF). It will be measured along Engineer markings on site.

005.5 Payment

The department will pay for the measured quantity at the contract unit price under the following bid item:

ITEM NUMBER	DESCRIPTION	UNIT
005.01	Sawing (Concrete)	LF
005.02	Sawing (Bituminous)	LF

005.6 Testing, Acceptance, & Maintenance

N/A



010-CONCRETE REMOVALS

010.1 General Description

- (1) This section describes the procedure for the removal of concrete curb & gutter, flatwork, and pavement within the City of La Crosse right of way.

010.2 Materials

- (1) Concrete shall be of a composition in accordance with the general concrete construction within this document.
- (2) Steel reinforcement used within the concrete will be in accordance with general steel reinforcement within this document.
- (3) Base material shall be of a composition in accordance with the general aggregate material procedure within this document.

010.3 Construction Methods

- (1) Equipment and tools necessary for performing all parts of the removal work shall be satisfactory as to design, capacity, and mechanical condition for the purposes intended, and any equipment which is not maintained in full working order, or which as used by the Contractor is inadequate to obtain the results prescribed, shall be repaired, improved, replaced, or supplemented to obtain the progress and workmanship contemplated by the contract.
- (2) All removals shall be sawn in accordance with the sawing section above prior to the start of removals.
- (3) All removals will be in accordance with the project plans and as marked by engineer in the field. Anything damaged or removed beyond the limits provided and without engineer's permission will be replaced at the contractor's expense.
- (4) Any and all obstructions (i.e. rock, tree roots, ext.) shall be removed prior to the installation of new concrete.
- (5) Removal depth shall include base and subgrade required to install the new pavement structure and curb & gutter at the designed elevations provided.

010.3.1 Curb & Gutter

- (1) Removals shall include up to a maximum of 12 inches behind curb & gutter.
- (2) Sawing of tree roots to provide clearance for new curb installation shall be included in the curb & gutter removal.

010.3.2 Flatwork

- (1) Removals shall include the following but not limited to:
 - A. Includes sidewalk, carriage walks, and driveway aprons.
 - B. Equipment to facilitate removal and transport of concrete and soil.
 - C. Excavation of six inches of existing soils if the soil is inadequate for proper support of new concrete.
 - D. Removal of obstructions if present to guarantee placement of new concrete.

010.3.3 Pavement

010.3.3.1 Standard

- (1) Use of self-propelled milling machine, standard excavation equipment, or combination of both can be used for full depth removal of pavement structure.
- (2) Pavement structure will include pavement and base course. Milling if used shall follow the standard procedure below.
- (3) Removals shall include the entire pavement structure to proposed elevation of roadway subgrade.
- (4) Concrete pavement may be between 7 and 12 inches in thickness. Base may be between 5 and 7 inches in thickness.

010.3.3.2 Milling

- (1) Milling shall remove the pavement surface to a depth specified in the plans maintaining the road cross slope.



Engineering Department

400 La Crosse St., La Crosse, WI 54601 • (608) 789-7505 • Fax: (608) 789-8184
<http://www.cityoflacrosse.org>

- (2) Use a self-propelled milling machine with depth, grade, and slope controls. Shroud the drum to prevent discharging loosened material into adjacent work areas or live traffic lanes. Provide an engineer-approved dust control.
- (3) Maintain one lane of traffic during working hours. Unless using a continuous removal and pick-up operation, do not windrow or store material on the roadway. Clear the roadway of materials and equipment during non-working hours. Grade shoulders adjacent to milled areas by the end of each work day to provide positive drainage of the pavement.
- (4) Do not allow abrupt longitudinal differences of 2 inches or more between lanes during non-working hours.
- (5) The engineer may waive one or more of these requirements if the highway is closed to traffic or if a particular operation does not endanger traffic.

010.4 Measurement

- (1) The department will measure the removal of Concrete Curb & Gutter by the Linear Foot (LF). It will be measured at the flowline of the curb and gutter. Catch basins will be skipped over while measuring.
- (2) The department will measure the removal of Concrete Flatwork by the Square Foot (SF).
- (3) The department will measure Concrete Pavement removal by the Square Yard (SY).

010.5 Payment

The department will pay for the measured quantity at the contract unit price under the following bid item:

ITEM NUMBER	DESCRIPTION	UNIT
010	Remove Concrete Curb & Gutter	LF
011	Remove Concrete Flatwork (Any Thickness)	SF
012.01	Remove Concrete Pavement (Standard)	SY
012.02	Remove Concrete Pavement (Milling)	SY

010.6 Testing, Acceptance, & Maintenance

N/A



015-BITUMINOUS REMOVALS

015.1 General Description

- (1) This section describes the procedure followed for the sawing of bituminous and concrete within the City of La Crosse right of way.

015.2 Materials

- (1) Bituminous shall be of a composition in accordance with the general bituminous construction within this document.
- (2) Base material shall be of a composition in accordance with the general aggregate material procedure within this document.

015.3 Construction Methods

- (1) Equipment and tools necessary for performing all parts of the sawing work shall be satisfactory as to design, capacity, and mechanical condition for the purposes intended, and any equipment which is not maintained in full working order, or which as used by the Contractor is inadequate to obtain the results prescribed, shall be repaired, improved, replaced, or supplemented to obtain the progress and workmanship contemplated by the contract.
- (2) All removals shall be sawn in accordance with the sawing section above prior to the start of removals.
- (3) All removals shall be in accordance with the project plans and as marked by engineer in the field. Anything damaged or removed beyond the limits provided and without engineer's permission will be replaced at the contractor's expense.

015.3.1 Standard

- (1) Use of self-propelled milling machine, standard excavation equipment, or combination of both can be used for full depth removal of pavement structure.
- (2) Pavement structure will include pavement and base course. Milling if used shall follow the standard procedure below.
- (3) Removal depth shall include base and subgrade required to install the new pavement structure at the designed elevations provided.

015.3.2 Milling

- (1) Use a self-propelled milling machine with depth, grade, and slope controls. Shroud the drum to prevent discharging loosened material into adjacent work areas or live traffic lanes. Provide an engineer-approved dust control.
- (2) Maintain one lane of traffic during working hours. Unless using a continuous removal and pick-up operation, do not windrow or store material on the roadway. Clear the roadway of materials and equipment during non-working hours. Grade shoulders adjacent to milled areas by the end of each work day to provide positive drainage of the pavement.
- (3) Do not allow abrupt longitudinal differences of 2 inches or more between lanes during non-working hours.
- (4) The engineer may waive one or more of these requirements if the highway is closed to traffic or if a particular operation does not endanger traffic.

015.4 Measurement

- (1) The department will measure Bituminous Pavement by the Square Yard (SY).

015.5 Payment

The department will pay for the measured quantity at the contract unit price under the following bid item:



Engineering Department

400 La Crosse St., La Crosse, WI 54601 • (608) 789-7505 • Fax: (608) 789-8184
<http://www.cityoflacrosse.org>

ITEM NUMBER	DESCRIPTION	UNIT
015.01	Remove Bituminous Pavement (Standard)	SY
015.02	Remove Bituminous Pavement (Milling)	SY

015.6 Testing, Acceptance, & Maintenance

N/A



020-TREE AND PLANTING REMOVALS

020.1 General Description

- (1) This section describes the procedure for the removal of all plantings, trees, and stumps within the City of La Crosse right of way.

020.2 Materials

- (1) Plantings and trees may be of any type and species.

020.3 Construction Methods

- (1) Equipment and tools necessary for performing all parts of the sawing work shall be satisfactory as to design, capacity, and mechanical condition for the purposes intended, and any equipment which is not maintained in full working order, or which as used by the Contractor is inadequate to obtain the results prescribed, shall be repaired, improved, replaced, or supplemented to obtain the progress and workmanship contemplated by the contract.
- (2) All removals will be in accordance with the project plans and as marked by engineer in the field anything damaged or removed beyond the limits provided and without engineer's permission will be replaced at the contractor's expense.

025.3.1 Tree Removal

- (1) Trees must be removed by either felling in one piece or sections. Area constraints (i.e. utilities, signs, etc.) shall dictate how the tree is to be brought down and removed.
- (2) Stump grubbing shall be included unless directed otherwise by the engineer.

025.3.2 Stump Removal

- (1) All stumps and surface roots shall be completely removed.
- (2) Stumps are to be removed by one of two methods: digging or grubbing.
- (3) Restoration shall be paid for under the restoration bid item. Restoration zone is the four inches below the surrounding ground elevation.
- (4) Any material or debris shall be disposed of properly off-site at an approved location.

025.3.2.1 Grubbing

- (1) When grubbing stumps, the stump shall be grubbed to a depth of ten inches below the surface as well as surface roots.
- (2) All large chips and pieces shall be removed and disposed of prior to any fill being placed.
- (3) Any fill needed to get area to within restoration zone shall be incidental.

020.4 Measurement

- (1) The department will measure Tree Removal & Stump Grubbing by the Diameter Inch (DI). Tree removal diameter shall be measured three feet off the ground.
- (2) Stump grubbing diameter shall be measured at the top of the existing stump.

020.5 Payment

The department will pay for the measured quantity at the contract unit price under the following bid item:

ITEM NUMBER	DESCRIPTION	UNIT
020.01	Tree Removal	DI
020.02	Stump Grubbing	DI

020.6 Testing, Acceptance, & Maintenance

N/A



1. GENERAL INSTALLATION

- 100 AGGREGATE MATERIALS
- 105 GENERAL CONCRETE CONSTRUCTION
- 110 STEEL REINFORCEMENT
- 114 DRILLED TIE & DOWEL BARS
- 115 CONCRETE PAVEMENT
- 120 CONCRETE SIDEWALK
- 121 DETECTABLE WARNING SURFACES
- 122 CONCRETE PEDESTRIAN CURB
- 125 CONCRETE CURB AND GUTTER
- 130 BITUMINOUS CONCRETE
- 135 CITY OF LA CROSSE RETAINING WALL
- 140 EROSION CONTROL
- 145 RESTORATION
- 150 TEMPORARY TRAFFIC CONTROL
- 155 CORE & POUR FINISHING



1. GENERAL INSTALLATION

100-AGGREGATE MATERIALS

100.1 General Description

- (1) This section describes the constructing of all base materials for projects of the City of La Crosse.

100.2 Materials

- (1) Aggregate material shall conform to WisDOT Standard Specifications for Highway and Structure Construction.
- (2) Dense-graded base shall conform to WisDOT Standard Specifications for Highway and Structure Construction.

100.3 Construction Methods

- (1) Base placement and compaction shall conform to WisDOT Standard Specifications for Highway and Structure Construction except as hereinafter modified.
- (2) Base shall be 1-1/4" dense graded base unless specified otherwise.
- (3) Base course shall be placed on shaped subbase material unless specified otherwise. Subbase shaping shall be completed by the utility contractor prior to base course placement.

100.4 Measurement

- (1) The department will measure base material by the square yard (SY) of base placed and compacted. The measurements will be based on field measurements or plan quantities.

100.5 Payment

The department will pay for the measured quantity at the contract unit price under the following bid item:

ITEM NUMBER	DESCRIPTION	UNIT
100.01-.02	Base Course (Thickness)	SY

100.6 Testing, Acceptance, & Maintenance

- (1) All testing shall conform to WisDOT Standard Specifications for Highway and Structure Construction except as hereinafter modified.
- (2) Contractor shall provide the City with a gradation test of base material. This test shall be incidental to this item.



105-GENERAL CONCRETE CONSTRUCTION

105.1 General Description

- (1) This section describes the proportioning, mixing, placing and protecting of concrete mixtures for projects of the City of La Crosse.
- (2) The following requirements must be fulfilled before grades are set and approval is given to commence work:
 - A. Contract forms to be completely executed.
 - B. Notice to utilities given.
 - C. Clearance from Engineer regarding disposal of surplus material, detouring of traffic, closing of streets and alleys, city facilities and services, shall be obtained by the Contractor.

105.2 Materials & Equipment

- (1) Equipment and tools necessary for performing concrete work shall be satisfactory as to design, capacity, and mechanical condition for the purposes intended, and any equipment which is not maintained in full working order, or which as used by the Contractor is inadequate to obtain the results prescribed, shall be repaired, improved, replaced, or supplemented to obtain the progress and workmanship contemplated by the contract.
- (2) All Concrete, Bituminous, and gravel pavements, sidewalks, curbs and gutters, fences, boulevard restoration, or other structures which may have been damaged or displaced by the Contractor in constructing the concrete shall be rebuilt or re-laid properly to the original line and grade in accordance with City of La Crosse Standard Procedures.
- (3) Portable job office shall be furnished by the Contractor during cold weather operations when requested by the Engineer. Suitable desk and bulletin board shall be provided as well as adequate heating and lighting facilities. The office shall be available to City Inspectors and other personnel designated at all times and shall be placed conveniently to the location of the work.
- (4) Portland cement shall conform to WisDOT Standard Specifications for Highway and Structure Construction.
- (5) Aggregate material shall conform to WisDOT Standard Specifications for Highway and Structure Construction.
- (6) All admixture materials shall conform to WisDOT Standard Specifications for Highway and Structure Construction.
- (7) Cure compounds shall conform to WisDOT Standard Specifications for Highway and Structure Construction.

105.3 Construction Methods

- (1) Removal of all Concrete, asphalt, trees, brush, sidewalk, or other surface materials shall be done in compliance with the City of La Crosse Standard Procedures.
- (2) Concrete forms and placement shall conform to WisDOT Standard Specifications for Highway and Structure Construction except as hereinafter modified.
- (3) The Contractor shall not, unless the proper parties have given written consent, enter or occupy with men, tools or materials any land adjoining the work.
- (4) The Contractor shall safeguard engineering stakes; and resetting, made necessary through carelessness of workmen, shall be done by the City at the Contractor's expense.

105.3.1 Curing Material

- (1) Liquid curing compound shall be white pigmented.
- (2) Starting the first of October, the city shall switch from the normal cure compound to TK AS-1 clear or equivalent. Compound shall be applied the day of the pour and reapplied between 7 to 28 days later
- (3) Starting the first of November, the city shall switch from the TK AS-1 to a clear siloxane or clear silane sealer or equivalent. Compound shall be applied three to seven days after the pour to allow as much water as possible out of the concrete before sealing.



105.3.2 Other Utilities

- (1) The location of pipes and other underground objects are approximately correct as shown on the plans, but should they be found to be otherwise, the Contractor shall have no claim on that account, it being understood that the Engineer does not warrant the plot of underground objects to be correct.
- (2) The Contractor shall notify all utilities, both public and private, including gas, electric, garbage collection, telephone, sewer and water, of his schedule of operations. The notice shall be given at least 48 hours prior to actual date of the commencing of construction. The Contractor shall also check as to any utility facilities which may be encountered during construction and take due notice of it.
- (3) The same notice and determination of facilities which may be encountered as well as to proposed blocking of streets or alleys shall be given to the Fire and Police Departments so as to enable them to maintain and plan their operations.
- (4) The Contractor shall give special attention to safeguarding and protecting all utilities, public and private, and shall be held liable for any damage thereto encountered during construction of the entire project. Relaying or relocating of gas mains to expedite construction of the sewer will be permitted providing it is done at no additional cost to the City following approval of such change by Xcel Energy and their agreement with the Contractor as to payment of costs incurred and specifications for the work. A notarized copy of such agreement, signed by the Contractor and Xcel Energy, shall be filed with the Board of Public Works before work is started.
- (5) Access to all hydrants and valves must be provided at all times because of emergency requirements of Water and Fire Departments.

105.3.3 Trees

- (1) The Contractor shall be responsible for trees damaged during the course of construction, as well as required trimming as directed by Engineering Department.

105.4 Testing & Acceptance

- (1) Contractor shall provide the City with of mix design sheets for all mixes used on the project along with where each mix is to be used.
- (2) Gradation tests shall be conducted and submitted to the City for aggregate gradation. This test shall be incidental to this item.
- (3) Contractor shall provide technical on admixtures and cure materials.
- (4) Cores shall be made according to AASHTO T23. Core containers shall be supplied by the contractor or concrete supplier. City Inspectors or Project Engineer shall make the cores unless contractor insists on making them.
- (5) Tested according to AASHTO T22. Cores shall be tested at an independent third-party lab or the lab must be WisDOT certified and certification must be submitted prior to the start of the project and approved. Testing shall be incidental to the items.
- (6) Results shall be within 100 psi of minimum open strength to pass. If results are none passing, then all material laid shall be removed and reinstalled at the contractors' expense.



110-STEEL REINFORCEMENT

110.1 General Description

- (1) This section describes the requirements for all steel reinforcement materials for projects of the City of La Crosse.

110.2 Materials

- (1) All steel reinforcement shall conform to AASHTO M31
- (2) All reinforcement coatings shall conform ASTM A775 and be on the WisDOT APL list.

110.3 Construction Methods

- (1) Reinforcement installation shall conform to WisDOT Standard Specifications for Highway and Structure Construction and City of La Crosse Standard Details.

110.4 Testing & Acceptance

- (1) Testing and acceptance shall conform to WisDOT Standard Specifications for Highway and Structure Construction except as hereinafter modified.



114-DRILLED TIE & DOWEL BARS

114.1 General Description

- (1) This section describes the furnishing and placement of steel tie bars and dowel bars.

114.2 Materials

- (1) Tie and dowel bars shall conform to the steel reinforcement section within this document.
- (2) Epoxy shall conform to WisDOT Standard Specifications for Highway and Structure Construction and on the WisDOT APL list.

114.3 Construction Methods

- (1) Tie bars may be installed by being epoxied into place or force driven.
- (2) Dowels shall be epoxied into place.
- (3) Drilled tie bars shall typically be #4 rebar at 12-inches in length and shall be space at 30-inches center to center spacing.
- (4) Drilled dowel bars shall be 0.75-1.25 inches in diameter and 18-inches in length and shall be spaced at 15-inches center to center spacing as defined in the table below.

Pavement Depth (in)	Dowel Bar Diameter
6-6 ½	¾"
7-7 ½	1"
8 & above	1 ¼"

114.3.1 Epoxy Installation

- (1) Drill holes into the edge of the existing concrete conforming to the City of La Crosse Detail Drawings.
- (2) All holes shall be free of drilling dust, debris, and excess moisture from holes before inserting the epoxy and dowel/tie bar.
- (3) Epoxy shall be injected into the back of the drill hole. Use an epoxy with a workable viscosity, pumpable, yet thick enough to remain in the hole. Insert a sufficient volume of epoxy into the hole to provide a small quantity of excess material at the face of the concrete after fully inserting the dowel. Contractor may use hand-powered mixing and injecting equipment capable of thoroughly mixing and depositing the epoxy at the back of the drill hole for minor quantities of dowel bars. Otherwise the use of a positive fixed displacement dispensing system, equipped with a nozzle of sufficient length to deposit the epoxy at the back of the drilled hole. The system shall be equipped with a means of checking the mix ratio of the epoxy components. Use the manufacturer's recommended mix ratio and check the ratio at least once a day.
- (4) Dowel bars shall be inserted in the drill holes and rotated 1/2 turn. Do not force drive dowel bars into the drill holes. The annular space between the dowel bar and the concrete shall to completely fill with epoxy. Insert a retaining ring over the bar, and push the ring flush against the concrete surface to retain the epoxy.
- (5) The exposed portion of each dowel bar shall be coated with a thin uniform layer of bond breaking lubricant.

114.3.2 Force Driven

- (1) Drill a hole suitably sized hole into the edge of the existing concrete.
- (2) Force drive the tie bar to a depth of six inches conforming to the City of La Crosse Detail Drawings.

114.4 Measurement

- (1) The department will measure both tie and dowel bars by an Each (EA) quantity for each bar drilled and installed.



Engineering Department

400 La Crosse St., La Crosse, WI 54601 • (608) 789-7505 • Fax: (608) 789-8184
<http://www.cityoflacrosse.org>

(2) Any bars drilled to connect new concrete pieces together will be incidental to the items.

114.5 Payment

The department will pay for the measured quantity at the contract unit price under the following bid item:

ITEM NUMBER	DESCRIPTION	UNIT
114.01	Drilled Tie Bars	EA
114.02	Drilled Dowel Bars	EA

114.6 Testing, Acceptance, & Maintenance

N/A



115-CONCRETE PAVEMENT

115.1 General Description

- (1) This section describes the constructing of concrete pavement for projects of the City of La Crosse.

115.2 Materials

- (1) Concrete shall conform to WisDOT Standard Specifications for Highway and Structure Construction and this document.
- (2) Reinforcement shall conform to WisDOT Standard Specifications for Highway and Structure Construction and this document.
- (3) Aggregate material shall conform to WisDOT Standard Specifications for Highway and Structure Construction and this document.
- (4) Joint sealant shall conform to WisDOT Standard Specifications for Highway and Structure Construction.

115.3 Construction Methods

- (1) Concrete pavement shall conform to WisDOT Standard Specifications for Highway and Structure Construction except as hereinafter modified.
- (2) Joint sealing and cleaning shall be incidental to concrete pavement. Joint sealing shall be completed within 6 months of substantial completion.
- (3) All concrete pavement shall have dowels and ties as shown in WisDOT Urban Doweled Concrete Pavement Detail unless otherwise noted.
- (4) Base aggregate shall be placed and shaped by contractor performing removals prior to placement of new pavement. Base aggregate shall be paid for under base aggregate item.

115.3.1 Concrete Alley

- (1) Alley pavement thicknesses shall be per the City of La Crosse Standard Detail Drawings.
- (2) Alley pavement centerline joint shall be keyed and tied.
- (3) Ties shall be No. 4 deformed bars, 30-inches long, and on 30-inches center to center
- (4) Keyway shall be installed per City of La Crosse Standard Detail Drawings.
- (5) Alley transverse joints shall not be doweled.

115.3.2 Concrete Aprons

- (1) Concrete driveway and alley aprons shall conform to City Municipal Code for width of allowable openings.
- (2) Concrete driveway and alley aprons do not require reinforcement unless noted.
- (3) Concrete driveway and alley aprons shall be per the City of La Crosse Standard Detail Drawings unless noted.

115.4 Measurement

- (1) The department will measure concrete pavement by the quantity of Square Yard (SY).

115.5 Payment

The department will pay for the measured quantity at the contract unit price under the following bid item:

ITEM NUMBER	DESCRIPTION	UNIT
115.01-.03	Concrete Pavement (Thickness)	SY
115.04-.05	Concrete Alley (Thickness)	SY
115.06-.07	Concrete Aprons (Thickness)	SY
115.08-.10	High-Early Concrete Pavement (Thickness)	SY
115.11-.12	High-Early Concrete Alley (Thickness)	SY



Engineering Department

400 La Crosse St., La Crosse, WI 54601 • (608) 789-7505 • Fax: (608) 789-8184
<http://www.cityoflacrosse.org>

115.13-.14	High-Early Concrete Aprons (Thickness)	SY
115.15-.17	Colored Concrete Pavement (Color, Thickness)	SY
115.18-.20	High-Early Colored Concrete Pavement (Color, Thickness)	SY

115.6 Testing, Acceptance, & Maintenance

115.6.1 Opening Strength

- (1) Opening strength shall be determined by compressive strength testing of cores.
- (2) Two samples shall be taken per paving unit. A paving unit is defined as 350 feet long by one lane width.
- (3) Cores shall be made according to AASHTO T23 and tested according to AASHTO T22. Cores shall be tested at an independent third-party lab or the lab must be WisDOT certified and certification must be submitted prior to the start of the project and approved. Testing shall be incidental to the items.
- (4) 7-day cores shall have a compressive strength of 3000 psi before opening to traffic.
- (5) 28-day cores shall have a minimum compressive strength of 4000 psi.



120-CONCRETE SIDEWALK

120.1 General Description

- (1) This section describes the constructing of sidewalk and curb ramps for projects of the City of La Crosse.

120.2 Materials

- (1) Concrete shall conform to WisDOT Standard Specifications for Highway and Structure Construction and this document.
- (2) Aggregate material shall conform to WisDOT Standard Specifications for Highway and Structure Construction and this document.

120.3 Construction Methods

- (1) Concrete sidewalk shall conform to WisDOT Standard Specifications for Highway and Structure Construction except as hereinafter modified.
- (2) All concrete sidewalk shall conform to the current version of Public Rights-of-Way Access Guidelines (PROWAG) unless specified otherwise.
- (3) All sidewalk shall be six feet wide unless specified otherwise.
- (4) All landings or City stones shall match adjacent midblock sidewalk width and shall be a minimum of five by five feet.
- (5) All sidewalk shall be planar.
- (6) Sidewalk shall be the following thicknesses:
 - A. Four-inch – standard and lead walks.
 - B. Five-inch - all ramps including the city stone, downtown district sidewalk, and others as indicated on plans.
 - C. Six-inch - all driveway sections.
- (7) Lead walks, constructed from sidewalk to back of curb, shall be a minimum of 36 inches wide and a maximum of 72 inches unless otherwise approved by Engineer.

120.3.1 Jointing

- (1) Transverse jointing shall be equal to the width except at driveways.
- (2) Expansion material shall be placed at the following instances:
 - A. Not be more than approximately 50 feet apart in running sidewalk.
 - B. Extensions of right-of-way lines at streets and alleys, or as directed by City staff.
 - C. Along the back of curb and buildings if sidewalk/ramp is poured up against them.
- (3) If sidewalk is poured wider than standard due to insufficient boulevard width, a construction joint shall be tooled in at six-foot wide longitudinal for ease of conduit and wire installation or repairs.

120.3.2 Ramps

- (1) Sidewalk ramps shall conform to City of La Crosse Details, except as otherwise directed.

120.4 Measurement

- (1) The Department will measure concrete flatwork by the quantity of Square Foot (SF).

120.5 Payment

The department will pay for the measured quantity at the contract unit price under the following bid item:

ITEM NUMBER	DESCRIPTION	UNIT
120.01-.04	Concrete Sidewalk (Thickness)	SF
120.05-.08	High-Early Concrete Sidewalk (Thickness)	SF



Engineering Department

400 La Crosse St., La Crosse, WI 54601 • (608) 789-7505 • Fax: (608) 789-8184
<http://www.cityoflacrosse.org>

120.6 Testing, Acceptance, & Maintenance

N/A



121-DETECTABLE WARNING SURFACES

121.1 General Description

- (1) This section describes the installation of detectable warning surfaces for projects of the City of La Crosse.

121.2 Materials

- (1) Detectable Warning Surface panels shall be "Neenah Detectable Warning Plate" R-4984 by Neenah Foundry or an equal with written approval from the project engineer.
- (2) Plates shall be cast iron and unpainted/natural.

121.3 Construction Methods

- (1) All detectable warning surfaces shall conform to the current version of Public Rights-of-Way Access Guidelines (PROWAG).
- (2) Detectable warning surfaces shall be installed per Standard Detail Drawings.
- (3) The concrete will be paid under the appropriate concrete sidewalk bid item.

121.4 Measurement

- (1) The Department will measure Detectable Warning Surfaces by the quantity of square foot (SF). The measurement will be taken along the center length of the placed warning surfaces multiplied by 2 foot width. Total measurement will be rounded up to the nearest square foot.

121.5 Payment

The department will pay for the measured quantity at the contract unit price under the following bid item:

ITEM NUMBER	DESCRIPTION	UNIT
121.01	Detectable Warning Surfaces	SF

121.6 Testing, Acceptance, & Maintenance

N/A



122-CONCRETE PEDESTRIAN CURB

122.1 General Description

- (1) This section describes the construction of concrete pedestrian curb within the project limits that have been approved by the City.

122.2 Materials

- (1) Concrete shall conform to WisDOT Standard Specifications for Highway and Structure Construction and this document.
- (2) Aggregate material shall conform to WisDOT Standard Specifications for Highway and Structure Construction and this document.
- (3) Tie bars shall conform to the WisDOT Standard Specifications for Highway and Structure Construction and this document.

122.3 Construction Methods

- (1) Concrete pedestrian curb shall conform to WisDOT Standard Specifications for Highway and Structure Construction except as hereinafter modified.
- (2) Prior to concrete pour, the contractor shall notify City staff and agree on final height of pedestrian curb. Any additional height poured beyond agreed height shall be at the contractor's expense. All styles, configurations, and heights shall be as directed by Engineer.
- (3) Pedestrian Curb shall be defined by type of construction, exposed height, and adjacent surface treatment.
- (4) All pedestrian curb shall have a vertical face with maximum 1" radius rounding the top of the curb.
- (5) All pedestrian curb shall be 6" in width.
- (6) When pedestrian curb is tied to adjacent sidewalk, #4 epoxy coated tie bars shall be used. Tie bars shall be spaced at 12" on center. Tie bars may be wet set or drilled into the sidewalk and shall be incidental to the cost of pedestrian curb. L-bars are required when exposed height is greater than 12".
- (7) Pedestrian curb behind a catch basin shall be incidental to the curb and gutter. This section shall be poured integral with the curb and gutter. It shall be poured full depth with a minimum 6" exposed height.
- (8) With private sidewalks that access right of way corners see City Engineer for final design.

122.3.1 Type A – Back of Sidewalk

- (1) Pedestrian curb shall be 6" to 23" in height exposed.
- (2) When adjacent to private side hardscape surface, pedestrian curb shall maintain a constant height 6" above existing grade behind back of sidewalk.
- (3) When adjacent to private side turf, pedestrian curb shall follow and match adjacent existing grade at back of sidewalk, maintaining a minimum 6" height exposed.
- (4) The pedestrian curb shall be tied to the adjacent sidewalk.
- (5) The pedestrian curb shall require form work.
- (6) Pedestrian curb shall be within sidewalk.

122.3.3 Type B – Front of Sidewalk

- (1) The pedestrian curb shall follow and match adjacent existing grade at front of sidewalk, boulevard area, and roadway curb and gutter.
- (2) Pedestrian curb shall be full depth.
- (3) The pedestrian curb shall be tied only when adjacent to turf.
- (4) The pedestrian curb shall require form work.
- (5) Pedestrian curb shall be within boulevard.



Engineering Department

400 La Crosse St., La Crosse, WI 54601 • (608) 789-7505 • Fax: (608) 789-8184
<http://www.cityoflacrosse.org>

122.4 Measurement

(1) The Department will measure pedestrian curb by the quantity of Linear Foot (LF).

122.5 Payment

The department will pay for the measured quantity at the contract unit price under the following bid item:

ITEM NUMBER	DESCRIPTION	UNIT
122.01-.02	Pedestrian Curb (Type)	LF

Payment is full compensation for providing all required materials, labor, and installation.

122.6 Testing, Acceptance, & Maintenance

N/A



125-CONCRETE CURB AND GUTTER

125.1 General Description

- (1) This section describes the constructing of concrete curb & gutter for projects of the City of La Crosse.

125.2 Materials

- (1) Concrete shall conform to WisDOT Standard Specifications for Highway and Structure Construction and this document.
- (2) Reinforcement shall conform to WisDOT Standard Specifications for Highway and Structure Construction and this document.
- (3) Aggregate material shall conform to WisDOT Standard Specifications for Highway and Structure Construction and this document.

125.3 Construction Methods

- (1) Concrete curb & gutter shall conform to WisDOT Standard Specifications for Highway and Structure Construction and detail drawings except as hereinafter modified.
- (2) Base course shall be incidental to curb & gutter items.
- (3) Curb and gutter at corner radii and storm structures shall be hand work.
- (4) Curb & gutter typical joint spacing shall be six to ten feet in length. If adjacent roadway is concrete, curb & gutter jointing shall be coincident with pavement panel length.
- (5) Expansion material shall be placed at the following instances:
 - A. Not be more than 160 feet apart in running curb & gutter.
 - B. Minimum of one side of alley openings.
 - C. Minimum of one stone beyond each end of radius at a corner.

125.3.1 Standard

- (1) Standard curb & gutter shall conform to WisDOT Standard Specifications for Highway and Structure Construction Type L curb except as hereinafter modified.
- (2) The gutter section shall have a 1-inch difference from flowline to front edge of gutter.

125.3.2 Gutter Only

- (1) Gutter only shall conform to City of La Crosse Standard Detail Drawings.

125.3.3 Bus Stop

- (1) Bus stop curb & gutter shall conform to WisDOT Standard Specifications for Highway and Structure Construction Type L curb and City of La Crosse Standard Detail Drawings.
- (2) Bus stop curb & gutter shall be 50 feet in length unless otherwise stated.

125.3.4 Reinforced Driveway

- (1) Reinforced driveway curb & gutter shall conform to City of La Crosse Standard Detail Drawings.

125.3.5 Traffic Circle

- (1) Traffic circle curb shall conform to WisDOT Standard Specifications for Highway and Structure Construction Type TBT curb and City of La Crosse Standard Detail Drawings.

125.3.6 Variable-Head

- (1) Variable-head curb & gutter shall conform to WisDOT Standard Specifications for Highway and Structure Construction Type L curb except as hereinafter modified.
- (2) Height shall vary according to the provide profile in the plan set.
- (3) The gutter section shall have a 1-inch difference from flowline to front edge of gutter.



125.4 Measurement

- (1) The department will measure all curb & gutter by a quantity of linear feet (LF). Curb & gutter shall be measured at the flowline of the curb & gutter and catch basin castings will be skipped while measuring.

125.5 Payment

The department will pay for the measured quantity at the contract unit price under the following bid item:

ITEM NUMBER	DESCRIPTION	UNIT
125.01-.06	Curb & Gutter (Type)	LF
125.07-.12	High-Early Curb & Gutter (Type)	LF

125.6 Testing, Acceptance, & Maintenance

125.6.2 Opening Strength

- (1) Opening strength shall be determined by compressive strength testing of cores.
- (2) Two samples shall be taken per 300 feet of non-continuous curb & gutter. Four samples shall be taken per 1500 feet of continuous curb & gutter.
- (3) Cores shall be made according to AASHTO T23 and tested according to AASHTO T22. Cores shall be tested at an independent third-party lab or the lab must be WisDOT certified and certification must be submitted prior to the start of the project and approved. Testing shall be incidental to the items.
- (4) 7-day cores shall have a compressive strength of 2500 psi before opening to traffic.
- (5) 28-day cores shall have a compressive strength of 4000 psi before opening to traffic.



130-BITUMINOUS CONCRETE

130.1 General Description

- (1) This section describes the furnishing and installation of bituminous concrete for projects of the City of La Crosse.
- (2) The following requirements must be fulfilled before grades are set and approval is given to commence work:
 - A. Contract forms to be completely executed.
 - B. Notice to utilities given.
 - C. Clearance from Engineer regarding disposal of surplus material, detouring of traffic, closing of streets and alleys, city facilities and services, shall be obtained by the Contractor.

130.2 Materials & Equipment

- (1) Equipment and tools necessary for performing concrete work shall be satisfactory as to design, capacity, and mechanical condition for the purposes intended, and any equipment which is not maintained in full working order, or which as used by the Contractor is inadequate to obtain the results prescribed, shall be repaired, improved, replaced, or supplemented to obtain the progress and workmanship contemplated by the contract.
- (2) All Concrete, Bituminous, and gravel pavements, sidewalks, curbs and gutters, fences, boulevard restoration, or other structures which may have been damaged or displaced by the Contractor in constructing the concrete shall be rebuilt or re-laid properly to the original line and grade in accordance with City of La Crosse Standard Procedures.
- (3) Portable job office shall be furnished by the Contractor during cold weather operations when requested by the Engineer. Suitable desk and bulletin board shall be provided as well as adequate heating and lighting facilities. The office shall be available to City Inspectors and other personnel designated at all times and shall be placed conveniently to the location of the work.
- (4) Asphaltic materials shall conform to WisDOT Standard Specifications for Highway and Structure Construction, Wisconsin Asphalt Pavement Association Design Guide, and this document.
- (5) Aggregate material shall conform to WisDOT Standard Specifications for Highway and Structure Construction, Wisconsin Asphalt Pavement Association Design Guide, and this document.
- (6) All admixture materials shall conform to WisDOT Standard Specifications for Highway and Structure Construction and Wisconsin Asphalt Pavement Association Design Guide.

130.3 Construction Methods

- (1) Bituminous concrete installation shall conform to WisDOT Standard Specifications for Highway and Structure Construction and the Wisconsin Asphalt Pavement Association Design Guide except as hereinafter modified.
- (2) Base aggregate shall be placed and shaped by contractor performing removals prior to placement of new pavement. Base aggregate shall be paid for under base aggregate item.

130.3.1 Bituminous Concrete Mixes

- (1) Design mixes are as follows:

Mix Design	Number of Layers	Single Layer	Upper Layer	Lower Layer	Base Depth
Overlays (including wedging)	Single Layer	5 HT 58-28 H	NA	NA	N/A
3" Residential	Single Layer	3 LT 58-28 S	NA	NA	6"
5" Residential/ Bus Route	Two Layers	NA	4 LT 58-28 S	3 LT 58-28 S	7"
5" Com/Indus	Two Layers	NA	4 MT 58-28 S	3 MT 58-28 S	7"
5" Industrial w/ slow traffic	Two Layers	NA	4 MT 58-58 H	3 MT 58-28 S	7"

130.3.2 Installation

- (1) All mixes shall include all prep work and tack coats required to complete the job.



130.3.3 Other Utilities

- (1) The location of pipes and other underground objects are approximately correct as shown on the plans, but should they be found to be otherwise, the Contractor shall have no claim on that account, it being understood that the Engineer does not warrant the plot of underground objects to be correct.
- (2) The Contractor shall notify all utilities, both public and private, including gas, electric, garbage collection, telephone, sewer and water, of his schedule of operations. The notice shall be given at least 48 hours prior to actual date of the commencing of construction. The Contractor shall also check as to any utility facilities which may be encountered during construction and take due notice of it.
- (3) The same notice and determination of facilities which may be encountered as well as to proposed blocking of streets or alleys shall be given to the Fire and Police Departments so as to enable them to maintain and plan their operations.
- (4) The Contractor shall give special attention to safeguarding and protecting all utilities, public and private, and shall be held liable for any damage thereto encountered during construction of the entire project. Relaying or relocating of gas mains to expedite construction of the sewer will be permitted providing it is done at no additional cost to the City following approval of such change by Xcel Energy and their agreement with the Contractor as to payment of costs incurred and specifications for the work. A notarized copy of such agreement, signed by the Contractor and Xcel Energy, shall be filed with the Board of Public Works before work is started.
- (5) Access to all hydrants and valves must be provided at all times because of emergency requirements of Water and Fire Departments.

130.3.4 Trees

- (1) The Contractor shall be responsible for trees damaged during the course of construction, as well as required trimming as directed by Engineering Department.

130.4 Measurement

- (1) The department will measure bituminous concrete pavement by the quantity of Square Yard (SY).
- (2) The department will measure overlay bituminous concrete pavement by the quantity of Ton (TON).

130.5 Payment

The department will pay for the measured quantity at the contract unit price under the following bid item:

ITEM NUMBER	DESCRIPTION	UNIT
130.01	Bituminous Concrete Pavement (Overlay)	Ton
130.02-.05	Bituminous Concrete Pavement (Design)	SY

130.6 Testing, Acceptance, & Maintenance

- (1) Bituminous concrete testing and acceptance shall conform to WisDOT Standard Specifications for Highway and Structure Construction and the Wisconsin Asphalt Pavement Association Design Guide except as hereinafter modified.



135-CITY OF LA CROSSE RETAINING WALL

135.1 General Description

- (1) This section describes the installation of a modular block gravity retaining wall within the City of La Crosse.

135.2 Materials

- (1) Work under this item shall consist of the designing, furnishing material, and erecting a modular block gravity wall.
- (2) The design of the retaining wall shall be in conformance with the latest edition of the AASHTO Standard Specifications for Highway Bridges including interim specifications, the Wisconsin Standard Specification for Highway and Structure Construction.
- (3) Wall Backfill, Type A, shall comply with the requirements for coarse aggregate No. 1 as given in Subsection 501.3.6.4.5 of the Standard Specifications. All backfill placed within a zone from the base of the leveling pad to the top of the final layer of wall facing units and within 12 inches behind the back face of the wall shall be Wall Backfill, Type A. This includes all material used to fill openings in the wall facing units.
- (4) Wall Backfill, Type B, shall comply with the requirements for Grade 1 Granular Backfill as contained in Subsection 209.2.2 of the Standard Specification. All backfill placed in a zone extending horizontally from one foot behind the back face of the wall and extending vertically from the base of the leveling pad to the top of the facing units shall be Wall Backfill, Type B.
- (5) Wall facing units shall consist of pre-cast modular concrete blocks. All units shall incorporate a mechanism or devices which will develop a mechanical connection between vertical block layers. A single block type and style shall be used throughout.
- (6) The top course of facing units shall be a solid pre-cast concrete unit designed to be compatible with the remainder of the wall. The finishing course shall be bonded to the underlying facing units with a durable, high strength, flexible adhesive compound compatible with the block material. A formed cast-in-place concrete cap may also be used to finish the wall. A cap of this type shall be designed to have texture, color, and appearance which complement the remainder of the wall. The vertical dimension of the cap shall not be less than 4 inches. Expansion joints shall be placed in the cap to correspond with each two-foot change in vertical wall height or a maximum spacing of 10 feet. Concrete for all cast-in-place caps shall be Grade A and shall conform to the requirements of Subsection 501.4 of the Standard Specifications.
- (7) Block dimension may vary no more than 1/8 inch from the standard values published by the manufacturer. Blocks must have a minimum width (depth) of 8 inches. The minimum front face thickness of blocks containing voids shall be four inches. The front face of the blocks shall be designated by the project manager. Concrete for modular block units shall develop a minimum compressive strength of 4,500 psi and have a water absorption rate of no more than 6%. Cement used for block manufacture shall be Type I, II, or III in accordance with ASTM C-150-89.
- (8) The wall leveling pad shall consist of poured concrete masonry Grade A as given in Section 501 of the WisDOT Standard Specifications or a compacted 30-inch by 6-inch aggregate base No. 2 as given in Section 304 of the WisDOT Standard Specifications.

135.3 Construction Methods

- (1) Material will be placed in the areas as indicated on the plans, as detailed in this specification, and as directed by the Engineer. Backfill lifts shall be no more than 8 inches in depth. Backfilling shall closely follow erection of each course of wall facing units. Compaction of Wall Backfill, Type A shall be accomplished by at least three passes of lightweight manually operated compaction equipment acceptable to the engineer. Wall Backfill, Type B shall be compacted to 95 percent of its maximum density as determined by AASHTO T-99, Method C.



Engineering Department

400 La Crosse St., La Crosse, WI 54601 • (608) 789-7505 • Fax: (608) 789-8184
<http://www.cityoflacrosse.org>

- (2) Backfilling operations shall be conducted in such a manner as to prevent damage or misalignment of the wall facing units. Any such damage or misalignment shall be corrected at the expense of the contractor as directed by the engineer.
- (3) No tracked vehicle or wheeled equipment may operate on the backfill within 5 feet of the exposed wall face. The engineer may order the removal of any large or heavy equipment which may cause damage or misalignment of the wall facing units.
- (4) The Modular Block Gravity Wall shall be constructed at the locations and to the dimensions shown on the plan and as directed by the engineer.
- (5) The surrounding area located above and below all precast block retaining wall sites shall be restored to its original condition and to the finished details on the plans after construction of the wall.

135.4 Measurement

- (1) The department will measure City of La Crosse Retaining Wall as a square footage of the exposed face of the retaining wall (SF).

135.5 Payment

The department will pay for the measured quantity at the contract unit price under the following bid item:

ITEM NUMBER	DESCRIPTION	UNIT
135.01	City of La Crosse Retaining Wall	SF

135.6 Testing, Acceptance, & Maintenance

- (1) City of La Crosse Retaining Wall acceptance shall conform to WisDOT Standard Specifications for Highway and Structure Construction.



140-EROSION CONTROL

140.1 General Description

- (1) This section describes the implementation of erosion control for projects of the City of La Crosse.

140.2 Materials

- (1) All erosion control devices and materials shall conform to WisDOT Standard Specifications for Highway and Structure Construction.

140.3 Construction Methods

- (1) Erosion control devices and materials shall be installed conforming to WisDOT Standard Specifications for Highway and Structure Construction, detail drawings, and City of La Crosse detail drawings.
- (2) If materials are stored on pavement, the contractor shall sweep the area to remove any remaining material from the roadway prior to opening to traffic.
- (3) If erosion control fails due to improper maintenance or improper installation, the contractor shall be responsible to clean all effected area. This can include but not limited to sucking out structures, jetting pipes, and others.

140.4 Measurement

- (1) The department will measure erosion control as a lump sum (LS) for the project. This item will be measured as follows:
 - 50% once erosion control is installed.
 - 100% once erosion control is removed.

140.5 Payment

The department will pay for the measured quantity at the contract unit price under the following bid item:

ITEM NUMBER	DESCRIPTION	UNIT
140.01	Erosion Control installation & Maintenance	LS

140.6 Testing, Acceptance, & Maintenance

- (1) Contractor shall be responsible for maintaining and inspecting erosion control to verify that it is following all standards. Maintenance shall be incidental to this item.



145-RESTORATION

145.1 General Description

- (1) This section describes the proper method from restoring boulevards and other turf areas for projects of the City of La Crosse.

145.2 Materials

- (1) Soil shall be pulverized black dirt containing 3 – 5% of organic matter.
- (2) Seed shall be the La Crosse Brand All Purpose Seed Mixture and shall be in conformance with Wisconsin State Law of the Department of Agriculture.
- (3) Fertilizer shall be a starter derived from urea formaldehyde (N-P-K = 6-24-24) and conform to the requirements of the state laws.
- (4) Organic Stabilizer/tackifier shall conform to WisDOT Standard Specifications for Highway and Structure Construction.
- (5) Erosion matting shall use a Class 1 Type A erosion control blanket stitched with degradable thread between photodegradable polypropylene top and bottom nets. Blanket shall be listed in the Wisconsin Produce Acceptability List (PAL).

145.3 Construction Methods

145.3.1 General

- (1.) Areas to receive restoration treatments include all turf grass areas as shown on plans, all disturbed areas and any other areas determined by the Project Engineer.

145.3.2 Soil Preparation

- (1.) Verify all areas to be treated are free of vegetation and other objectionable material. Verify that required thickness of soil is provided and at final grade specified. All areas shall be uniformly compacted. If any low areas develop, the contractor shall be responsible to add soil as needed, compact and retreat.

145.3.3 Applications

(1.) General

- A. All areas shall be seeded with the following application rate per 1000 square feet:
 1. Fertilizer – 11.5 lbs
 2. Seed – 5 lbs

(2) Hydroseeding

A. Equipment

1. Equipment shall be a truck mounted commercial-type Hydro-Seeder with built-in agitation system with an operation capacity sufficient to agitate, suspend, and homogeneously mix slurry.
2. Shall have a minimum of a 1500-gallon capacity.
3. Distribution lines shall be large enough to prevent stoppage and allow for even distribution over the site.
4. Pump shall be able to generate 150 PSI at the nozzle.

B. Preparation

1. All preparations shall be done on site.
2. All ingredients except seed shall be added last.
3. 46 pounds of cellulose or wood fiber shall be used per 1000 square feet.
4. Mixture shall be agitated for 3-5 minutes to allow for uniform mixing.

C. Application

1. Hydro-seed applications shall be applied in a sweeping motion to form a uniform application and form a mat.



Engineering Department

400 La Crosse St., La Crosse, WI 54601 • (608) 789-7505 • Fax: (608) 789-8184
<http://www.cityoflacrosse.org>

2. Each batch shall be discharged within two hours for seed being added. After the two hours one-half of the seed rate must be added and remixed and timer reset.
 3. If mixture remains in the tank for more than eight hours than the contractor shall remove it and dispose of it properly from the job site at their expense.
- (3) **Cold Weather**
- A. In early October the Project Engineer shall notify the contractor when cold weather seeding is to take effect.
 - B. With cold weather seeding restrictions the contractor can do one of the following approved options:
 1. Option one: Wait to seed in the spring
 2. Option two: Apply seed and fertilizer as usual but cover with the appropriate erosion matting to ensure protection of seed through the winter. No additional compensation above and beyond contract price will be given for this.

145.3.4 Clean-up

- (1.) All turf areas and staging areas shall be maintained in a neat and orderly condition.
- (2.) Paved areas are to remain free of soil.
- (3.) Contractor is responsible for removing all associated materials and debris from project site as well as cleaning excess material from areas not intended to get treated.
- (4.) If Erosion matting is used, contractor shall go back once grass is established and remove any mesh, staples, or matting that could cause damage to mowing equipment.

145.4 Measurement

- (1) The department will measure restoration by the square yard (SY). The measurements will be based on field measurements or plan quantities.

145.5 Payment

The department will pay for the measured quantity at the contract unit price under the following bid item:

ITEM NUMBER	DESCRIPTION	UNIT
145.01-.02	Restoration (Type)	SY

145.6 Testing, Acceptance, & Maintenance

- (1) Project engineer shall inspect that all work was done in compliance of the specifications and accept each area.
- (2) Project engineer reserves the right to request samples be taken and tested for conformity to the specifications. All test shall be incidental to the item.
- (3) Any rejected materials shall be the contractor's responsibility to dispose of at a proper location and supply new acceptable material.
- (4) Acceptance shall be when 85% of grass is at full maturity and that there are no obvious bare spots.
- (5) Contractor shall provide a one-year warranty from the date of acceptance.
- (6) Contractor shall be responsible for all soil testing and shall provide test results to the Project Engineer upon request.



150-TEMPORARY TRAFFIC CONTROL

150.1 General Description

- (1) This section describes the implementation of temporary traffic control within the project limits.

150.2 Materials

- (1) All device and barricade materials and size will follow the Manual on Uniform Traffic Control Devices (MUTCD) temporary traffic control guidelines.
- (2) All traffic control materials shall conform to WisDOT Standard Specifications for Highway and Structure Construction.

150.3 Construction Methods

- (1) Traffic control shall be set per the attached plan or follow WisDOT/MUTCD examples if no plan is provided.
- (2) Contractor shall be responsible to coordinate setup and tear down of traffic control.
- (3) Maintenance of devices shall be the contractor’s responsibility. This shall be done daily to ensure all devices are upright and visible for public safety. Contractor shall be available for emergency response within 2 hours.

150.4 Measurement

- (1) The department will measure temporary traffic control as a lump sum (LS) for the project. This item will be measured as follows:
 - A. 50% once traffic control is set, street is officially closed with engineer’s approval.
 - B. 100% once traffic control is picked up and no longer needed.

150.5 Payment

The department will pay for the measured quantity at the contract unit price under the following bid item:

ITEM NUMBER	DESCRIPTION	UNIT
150.01	Temporary Traffic Control & Maintenance	LS

150.6 Testing, Acceptance, & Maintenance

150.6.1 Testing & Acceptance

- (1) Inspector or Project Engineer shall verify all barricades are in their correct position and location around the work site per plans provided.
- (2) Inspector or Project Engineer shall verify all detours are correctly signed per plans provided before acceptance.

150.6.2 Maintenance

- (1) Contractor shall be responsible for maintaining all control devices.
- (2) If any City official reports a device defective, that device shall be exchanged for an approved device within 24 hours.



155-CORE & POUR FINISHING

155.1 General Description

- (1) This section describes the installation of Core & pour manhole finishing of all manholes within project limits.

155.2 Materials

- (1) Concrete shall conform to WisDOT Standard Specifications for Highway and Structure Construction and this document.
- (2) Reinforcement shall conform to WisDOT Standard Specifications for Highway and Structure Construction and this document.
- (3) Aggregate material shall conform to WisDOT Standard Specifications for Highway and Structure Construction and this document.
- (4) Bituminous concrete shall conform to WisDOT Standard Specifications for Highway and Structure Construction and this document.

155.3 Construction Methods

- (1) The contractor shall give the engineer notice to guarantee GPS equipment availability three (3) days prior to removal of casting and rings of manholes.
- (2) Engineer shall work with contractor and locate the center of the manholes prior to the contractor plates manholes to ensure Core & Pour is properly centered. Plates will not be used for location of structure.
- (3) After paving of the project but three (3) days prior to coring, the contractor shall give the engineer notice to guarantee GPS equipment availability and to locate the center of structures for contractor. Engineer will instruct contractor how centered are to be marked so there is no confusion of marks.
- (4) A 4-foot diameter coring bit shall be used to cut through bituminous cement and aggregate material.
- (5) Bituminous cookie and aggregate material shall be removed and excavated to expose plate.
- (6) Manhole rings shall be installed at this point to bring casting up final elevation.
- (7) Area shall be back filled and compacted to within eight (8) inches below bituminous surface for concrete.
- (8) A single #4 3-foot diameter epoxy coated bar shall be placed in the concrete area.
- (9) Concrete shall be poured and reinforcement centered in thickness of collar.
- (10) Collar shall be finished with a broom finish, access concrete removed from casting and casting pockets so casting can be removed.
- (11) Once concrete has ample cure time the joint between the concrete and bituminous concrete shall be sealed with a CSSI or approved equal sealer. All edges shall be tacked and sand sealed. Any gap between casting and rings shall be filled with mortar and rings skim coated per sewer procedures within this document.

155.4 Measurement

The department will measure the item by the quantity of each (EA) for every completed manhole.

155.5 Payment

The department will pay for the measured quantity at the contract unit price under the following bid item:

ITEM NUMBER	DESCRIPTION	UNIT
155.01	Core & Pour Finishing	EA

155.6 Testing, Acceptance, & Maintenance

- (1) Core & pour collar shall be within 1/8 of an inch of the surrounding bituminous concrete without being higher than.



2. STORM SEWER CONSTRUCTION

- 200 GENERAL STORM SEWER CONSTRUCTION
- 201 EXCAVATION, BEDDING, & BACKFILL
- 205 STORM SEWER PIPE
- 220 STORM SEWER STRUCTURE CONSTRUCTION
- 230 REPAIR/MODIFY EXISTING STORM SEWER STRUCTURE
- 240 BIORETENTION CELLS (BIO-CELLS)



2. STORM SEWER CONSTRUCTION

200-GENERAL STORM SEWER CONSTRUCTION

200.1 General Description

- (1) Perform work in accordance with the provisions of WisDOT Standard Specifications for Highway and Structure Construction except as hereinafter modified.
- (2) The following requirements must be fulfilled before grades are set and approval is given to commence work:
 - A. Contract forms to be completely executed.
 - B. Notice to utilities given.
 - C. Clearance from Engineer regarding disposal of surplus material, detouring of traffic, closing of streets and alleys, city facilities and services, shall be obtained by the Contractor.

200.2 Equipment & Materials

- (1) Equipment and tools necessary for performing all parts of the storm sewer work shall be satisfactory as to design, capacity, and mechanical condition for the purposes intended, and any equipment which is not maintained in full working order, or which as used by the Contractor is inadequate to obtain the results prescribed, shall be repaired, improved, replaced, or supplemented to obtain the progress and workmanship contemplated by the contract.
- (2) The Concrete used in the construction and installation of sewers, structures, catch basins, inlets and other structures and appurtenances shall conform to the requirements for General Concrete as specified in the City of La Crosse Standard Procedures.
- (3) All Concrete, Bituminous, and gravel pavements, sidewalks, curbs and gutters, fences, boulevard restoration, or other structures which may have been damaged or displaced by the Contractor in constructing the sewer shall be rebuilt or re-laid properly to the original line and grade in accordance with City of La Crosse Standard Procedures.
- (4) Portable job office shall be furnished by the Contractor during cold weather operations when requested by the Engineer. Suitable desk and bulletin board shall be provided as well as adequate heating and lighting facilities. The office shall be available to City Inspectors and other personnel designated at all times and shall be placed conveniently to the location of the work.

200.3 Construction Methods

- (1) Removal of all Concrete, asphalt, trees, brush, sidewalk, or other surface materials shall be done in compliance with the City of La Crosse Standard Procedures.
- (2) The Contractor shall not, unless the proper parties have given written consent, enter or occupy with men, tools or materials any land adjoining the work.
- (3) The Contractor shall safeguard engineering stakes; and resetting, made necessary through carelessness of workmen, shall be done by the City at the Contractor's expense.
- (4) The sewer is to be kept entirely free from rubbish of every kind as its construction progresses. All refuse and surplus matter must be scraped off. The same provisions are to be complied with in regard to catch basins and manholes.
- (5) No masonry, mortar or other cement work shall be done during freezing weather unless the Contractor shall provide the necessary means for, and shall heat the bricks, gravel, sand and water, and shall comply with all requirements to thoroughly protect the masonry from frost during and after laying; all at the cost and expense of the Contractor and with the approval of the Engineer.

200.3.1 Dewatering

- (1) The Contractor shall keep all excavations free of water during and until completion of the work, as directed by the Project Engineer. The Contractor shall be responsible for the continuous control of water at all times during the



course of construction, and shall provide adequate backup systems to accomplish control of water entering excavations, trenches, and other parts of the work and shall keep said excavations dry until the structures or utilities to be built therein are completed.

- (2) No masonry or concrete shall be installed in water nor shall water be allowed to rise over masonry and/or concrete at least twenty-four (24) hours after the concrete has been placed. Water shall be controlled during periods when concrete is being placed, when pipe is being laid, and as such other times as is necessary for efficient and safe execution of the work.
- (3) The Contractor shall protect all local water supplies from harm as a result of dewatering operations, and provide remedial measures for any situations where such harm occurs.
- (4) All water removed from the construction site shall be discharged through pipes or hoses. The conveying of water in open ditches or trenches will not be allowed. Water shall be discharged in a manner that will not cause soil erosion at the discharge point. Discharge shall not cause siltation or flooding in any stream, storm sewer, or on adjacent properties.
- (5) All costs for making all extra excavations necessary to prevent the water from interfering with the proper construction of the work, bailing, pumping, and dewatering shall be borne by the Contractor, and included in the prices bid for other items of work. All required pumping, drainage, and disposal of groundwater shall be done without damage to adjacent property or structures, or to the operations of other Contractors and without interference with the access rights of public or private parties. The Contractor shall modify the water control system at their own expense if, after installation and while in operation, it causes or threatens to cause damage to adjacent property or to existing buildings, structures, or utilities.

200.3.2 Other Utilities

- (1) The location of pipes and other underground objects are approximately correct as shown on the plans, but should they be found to be otherwise, the Contractor shall have no claim on that account, it being understood that the Engineer does not warrant the plot of underground objects to be correct.
- (2) The Contractor shall notify all utilities, both public and private, including gas, electric, garbage collection, telephone, sewer and water, of his schedule of operations. The notice shall be given at least 48 hours prior to actual date of the commencing of construction. The Contractor shall also check as to any utility facilities which may be encountered during construction and take due notice of it.
- (3) The same notice and determination of facilities which may be encountered as well as to proposed blocking of streets or alleys shall be given to the Fire and Police Departments so as to enable them to maintain and plan their operations.
- (4) The Contractor shall give special attention to safeguarding and protecting all utilities, public and private, and shall be held liable for any damage thereto encountered during construction of the entire project. Relaying or relocating of gas mains to expedite construction of the sewer will be permitted providing it is done at no additional cost to the City following approval of such change by Xcel Energy and their agreement with the Contractor as to payment of costs incurred and specifications for the work. A notarized copy of such agreement, signed by the Contractor and Xcel Energy, shall be filed with the Board of Public Works before work is started.
- (5) Access to all hydrants and valves must be provided at all times because of emergency requirements of Water and Fire Departments.

200.3.3 Trees

- (1) The Contractor shall be responsible for trees damaged during the course of construction, as well as required trimming as directed by Engineering Department.

200.3.4 Private Connections

- (1) Any private storm connections to the sewer system must be approved by City Staff prior to work commencing.



Engineering Department

400 La Crosse St., La Crosse, WI 54601 • (608) 789-7505 • Fax: (608) 789-8184
<http://www.cityoflacrosse.org>

- (2) All connections must go to either a storm manhole or catch basin. Pipe-to-pipe and “Doghouseing” connections will be prohibited.
- (3) If no storm structure is in close proximity to a proposed connection point, the private entity will be required to pay for and install an approved structure, as described in later in this section. Upon completion and inspection of the new structure and connection, the structure shall be donated to the City. The storm lateral, connection, and any other part beyond the structure shall be the responsibility of the private entity.

200.4 Testing, Acceptance, & Maintenance

N/A



201-EXCAVATION, BEDDING, & BACKFILL

201.1 General Description

- (1) Work in this section shall consist of excavations, preparation, and backfilling required for placing of storm sewer pipes, fittings, or structures.

201.2 Materials

- (1) Bedding and Backfill material shall conform to WisDOT Standard Specifications for Highway and Structure Construction. The use of reclaimed asphalt, reprocessed material, or blended material shall not be allowed.

201.2.1 Bedding Material

- (1) Bedding material shall conform to WisDOT $\frac{3}{4}$ " dense graded base gradation. Native materials meeting the bedding requirements may be used for the installation of storm sewer in the judgement of the Engineer, is free from debris and organic material, and meets the gradation requirements.

201.2.2 Backfill Material

- (1) Backfill material shall conform to WisDOT 1 $\frac{1}{4}$ " dense graded base gradation. Excavated material may be used as backfill if it is suitable material in the judgement of the Engineer, is free from debris and organic material, and meets the gradation requirements.

201.3 Construction Methods

- (1) All excavations, bedding material, or backfilling material shall be incidental to the storm sewer pipe or structure.

201.3.1 Excavation

- (1) The excavations must either be sloped or supported as required to comply with OSHA Excavation standards as defined in 29 C.F.R. Part 1926, Subpart P.
- (2) The trench in which the sewer and appurtenances are to be constructed shall be excavated in all cases in such manner and to such depths and widths as will give suitable room for the building of the structures they are to contain, and for bracing and supporting, pumping and draining, and for removing from the trench peat, silt or other materials which may not be deemed proper for foundations.
- (3) Not more than one city block of trench shall be opened in advance of the completed sewer, except by permission of the engineer, nor shall the limits of such open trench extend simultaneously across two streets intersecting the street in which the work is being done; nor in the case of a sheathed trench shall the opening in the street extend farther in length than the amount of sheathing physically present on the site.
- (4) The bottom of the trench is, in general, to be excavated to the exact form and size of the lower portion of the sewer which is to be laid in it. In case of pipe sewer, the bottom of the trench shall be trimmed, to the form of the outside of the pipes, with additional excavation at the joints, so that the bearings shall be continuous and the pressure shall be equally distributed.
- (5) Where salvageable material such as crushed rock or stone, of a depth of 6" or more, is encountered in excavation for utility installation, such material shall be carefully removed and segregated for future use by the City or as directed on the project by the Engineer. In such cases, the Engineer shall order removal and segregation of materials considered salvageable, where it shall be stored, and whether or not it is to be used by the Contractor in final backfilling operations on the project involved. Contractor shall be compensated for hauling of salvaged material on the same basis as for excess dirt or debris.
- (6) All materials shall be so placed as not to endanger the work, and so free access may be had at any time to all parts of the trench and all hydrants and gate valves in the vicinity. They shall be kept neatly piled so as to inconvenience as little as possible the public travel or the adjoining tenants. Reasonable provision shall be made for travel on the streets, roads, railroads and private ways.



Engineering Department

400 La Crosse St., La Crosse, WI 54601 • (608) 789-7505 • Fax: (608) 789-8184
<http://www.cityoflacrosse.org>

- (7) Care shall be taken not to move, without the consent of the engineer, any sewers, drains, water or gas pipes, or other structures, and in crossing these, and in running parallel or near them, they shall be sustained securely in place until the work is completed. Whenever it is necessary to interfere with said structures, the Contractor shall maintain their respective services, and if necessary for that purpose, shall lay temporary water, gas or other pipes. The Contractor shall repair all damage done to any of said structures, and shall leave them in as good condition as they were previous to the commencement of the work. If so directed by the engineer, permanent changes of location not indicated on the plans nor in specifications shall be made by the Contractor to meet the requirements of the sewer and appurtenances, and new work shall be added, when necessary, to leave all in good working order. The cost of such permanent changes not indicated on the plans nor in the specification is to be paid for as extra work, on the valuation of the Board of Public Works, and depending on the decision of the engineer as to whether the work done is or is not included in the work required by the Contractor under his contract. Any damage done or caused to said pipes or other existing structures by act or neglect on the part of the Contractor is to be paid by him.
- (8) The Contractor shall be responsible for disposing of all excess dirt and debris resulting from construction. The City will not furnish a disposal site unless otherwise stated on the plans or in the Special Specifications.
- (9) No stone monuments, bench marks, etc., of any description, located in line of the work, shall be removed or taken up unless it be in the presence of the Engineer or City Inspector.

201.3.2 Rock Excavation

- (1) Rock excavation shall be defined as removal of igneous or sediment deposits laying in solid beds or layers in their original position which cannot be removed with the types of excavating machinery usually employed for trench excavation of the character involved in this contract. Rock excavation shall also include removal of boulders larger than $\frac{1}{2}$ cubic yard in volume and of ledge rock, concrete or masonry structures that require drilling or blasting. Rock excavation shall not include removal of boulders less than $\frac{1}{2}$ cubic yard in volume, loose rock, or soft, friable, decomposed rock able to be removed with normal excavation equipment.
- (2) Where rock is encountered, the ditch width shall be narrowed to the minimum width required for laying of the pipe subject to the approval of the engineer. The pay width for rock excavation shall be the average width of the excavated trench but shall not exceed the outside pipe diameter plus 2 feet. The trench shall be excavated 4 inches below the outside of the pipe barrel and the exterior of all joints.
- (3) Volumetric measurement of rock in the trench shall be the basis for determining the quantity of rock excavation and shall be computed from average trench width, top of rock profile, and profile 4 inches below exterior of pipe joints. Boulders in excess of $\frac{1}{2}$ cubic yard volume will be based on actual volume removed from the trench. The pay quantity for rock excavation for manholes and structures will be one foot beyond the outside neat lines of the manhole or structure.
- (4) If blasting is to be used to remove rock, the Contractor must first obtain a blasting permit from the Mayor as required under Municipal Code 18-2.
- (5) The Wisconsin Administrative Code on Explosives and all local ordinances regulating blasting shall be adhered to. The Contractor will be held responsible for any damage to work performed by others or to adjacent property due to his blasting operation.

201.3.3 Bedding

- (1) The bedding, or foundation, for sanitary sewer pipes shall be constructed to prevent settlement of the pipes and to avert excessive pressure on the pipes in order to avoid rupture, leakage, or deformation of the pipes.
- (2) The Contractor may use existing undisturbed ground for pipe foundation if approved by the Engineer or City Inspector.
- (3) After the excavation is complete, a layer of bedding material shall be spread over the bottom of the trench at a minimum depth of four (4) inches. The pipe can be installed and jointed with a uniform support from the bedded



material. The bedding material shall be brought up to a level even with the spring line of the pipe and carefully compacted by hand when the trench is wet.

201.3.4 Backfilling

- (1) All excavations shall be backfilled as ordered by the Engineer or City Inspector, unless other protection of the pipeline is directed. The backfill should be solidly tamped about the pipes up to a level at least one foot above the top. This material should be deposited in uniform layers of 6 inches or less. Unless otherwise permitted, each layer should be solidly tamped or rammed with proper tools so as not to disturb the pipeline. Backfill material shall be clean and approved by the engineer, free from rocks or broken concrete exceeding 2 inches in size.
- (2) The remainder of the excavation shall be backfilled by mechanical compaction methods. Backfill shall be placed in layers not generally exceeding 12 inches in depth, and each layer thoroughly compacted before the following layer is placed.
- (3) The mechanical compaction equipment shall be capable of compacting the backfill to the specified density. If not otherwise specified, the required density shall be 95% of maximum (Proctor) density. Prior to backfilling, the Engineer or City Inspector shall approve the type of mechanical compaction equipment and the compaction method.
- (4) The Engineer reserves the right to reject any compaction method that may damage the sewer pipe or other utilities or structures. This does not relieve the Contractor of any liability for such damage.
- (5) As the work progresses, all rubbish or refuse, and all unused materials and tools shall be removed at once from the ground. Whenever this clearing of rubbish from the streets, or the repairing of the street surfaces, fences or other damage is neglected, notice may be given to that effect to the Contractor, and if said rubbish is not removed or said repairs not done within two days thereafter, or if the Contractor does not at once take the necessary precautions to insure safety of public travel, the Board may employ other parties to do such work and the expense thus incurred will be deducted from any moneys due or that may become due the Contractor.
- (6) When, for any reason, the work is left unfinished, all excavations shall be filled if so required and the roadways and sidewalks be left unobstructed, and with the surfaces in a safe and satisfactory condition.
- (7) No excavated material, except the road surfacing and a limited amount of sand and gravel to be used for masonry, shall be left on the streets; but such materials shall be backfilled into the trench or carted away.

201.4 Testing, Acceptance, & Maintenance

- (1) **At the request of the Engineer or Inspector**, the Contractor shall provide gradation testing for bedding material or backfill material. The gradation test shall be incidental to the pipe or structure removal, install, or replacement.



205-STORM SEWER PIPE

205.1 General Description

- (1) This section describes removing, abandoning, replacing, or installing new storm sewer pipe of varying material types. The materials furnished and installed shall conform to the requirements specified herein for the type and class of material named in the plan.

205.2 Materials

- (1) Furnish pipe consistent with the pipe material and diameter bid item indicated in the plan. Alternative pipe material may be used if approved by the Assistant Superintendent of Waste Water Utility of prior to material delivery. Base materials and backfilling materials shall conform to City of La Crosse Standard Procedures.
- (2) Unless otherwise directed by the Engineer, all pipe and accessories shall be unloaded at the point of delivery, and hauled to and distributed at the site of the work by the Contractor. The materials shall be at all times handled with care to avoid damage. The material shall not be dropped or bumped against the ground, other pipe and accessories already on the ground, or any other object on the ground.
- (3) The contractor shall furnish random lengths of pipe for each contract as may be required for the proper placement of fittings or structures.
- (4) Unless otherwise specified, references to various standard specifications and test methods shall be understood to mean the specification or test method which is current on the date of awarding of bid.

205.2.1 Remove/Abandon/Replace

- (1) The existing storm sewer pipe may consist of PVC, HDPE, PP, clay pipe, ductile iron, concrete pipe, or reinforced concrete pipe.

205.2.2 Poly-Vinyl Chloride Pipe (PVC)

- (1) Solid-wall Poly-Vinyl Chloride (PVC) pipe and fittings, labeled as "PVC" on the plans, shall conform to the requirements of the Specification for Type PSM PVC Sewer Pipe and Fittings, ASTM D-3034, SDR-35 or SDR-26 and ASTM F-679, PS 46 or PS 115. Fittings such as saddles, elbows, tees, wyes, and others shall be of material and construction corresponding to, and have a joint design compatible with the adjacent pipe.
- (2) SDR-35 or PS 46 shall be used in depths up to 15 feet below finished surface. SDR-26 or PS 115 shall be used with depths greater than 15 below finished surface.
- (3) Rubber gasket conforming to ASTM D 3212 (F477) shall be used. This shall be a bell and spigot joint, sealed by a rubber gasket so that the assembly will remain watertight under all conditions of service, including the movements resulting from the expansion, contraction, settlement and deformation of the pipe.
- (4) Connections to storm structures with PVC shall be booted in accordance with manufacturer's specifications.

205.2.3 Reinforced Concrete Pipe (RCP)

- (1) Reinforced Concrete Pipe, fittings, and accessories, labeled as "RCP" on the plans, shall conform to the requirements of the Specification for Reinforced Concrete Culvert, Storm Drain, and Sewer Pipe, ASTM C-76.
- (2) Concrete pipe shall be provided without lifting holes.
- (3) Fittings shall be supplied by the manufacturer of the pipe unless approved by the Project Engineer. Rubber gasket shall conform to the requirements of the Specification for Joints for Circular Concrete Sewer and Culvert Pipe, Using Rubber Gaskets, ASTM C-443.
- (4) Connections to storm structures with RCP shall be brick and mortared.

205.3 Construction Methods

- (1) The foundations, or bedding, in the trench shall be formed to prevent any subsequent settlement, which might result in excessive pressure and consequent rupture of the pipes. If the foundation is rock, an equalizing bed of



concrete or sand shall be placed upon the rock and well compacted. The thickness of these beds shall be not less than four inches. If the foundation is good firm earth, the earth shall be pared or molded to give a full support to the lower third of each pipe, and, if necessary to secure a proper bearing for the pipe, a layer of concrete, fine gravel, or other suitable material shall be placed. The same means of securing a firm foundation shall be adopted in case the excavation has been made deeper than necessary.

- (2) Dewatering and televising shall be incidental to these items.

205.3.1 Removal

- (1) Removal limits are as shown on plans or by field markings done by engineer. Any removals or damage caused beyond this point without the engineer's permission will be the responsibility of the contractor to replace at their expense. The contractor shall follow City of La Crosse Standard Procedures for excavation, trenching or shoring, and backfilling operations.
- (2) Removals shall include the following but not limited to:
 - A. Equipment to facilitate removal and transport of pipe and soil.
 - B. Removal of pipe and offsite disposal.
 - C. Capping remaining pipe or structure if needed.
 - D. Additional Backfill material if needed.

205.3.2 Abandon

- (1) Abandon limits are shown on plans and/or by field markings done by engineer. Any damage caused beyond this point without the engineer's permission will be the responsibility of the contractor to replace at their expense.
- (2) Pipes identified on the plans for abandonment shall be plugged or filled with flowable fill as specified on the plans. The pipe shall be bulk headed and completely filled with a slurry like mixture.
- (3) If the pipe is going to a Sanitary Manhole, the pipe shall be plugged at the manhole and at the abandonment location.

205.3.3 Pipe Laying

- (1) The laying of pipes in finished trenches shall commence at the lowest point and shall proceed towards the upper end, and the pipe shall be laid so that the spigot or tongue ends point in the direction of flow. All pipes shall be laid with ends abutting and true to line and grade. They shall be fitted and matched so that when laid in the work they will form a sewer with a smooth and uniform invert.
- (2) The Contractor is responsible for maintaining line and grade for all pipes laid. The method used shall provide accurate line and grade for the existing construction conditions. The Contractor will be required to re-lay any pipe not installed on proper line or grade.
- (3) New and replaced storm sewer pipe shall be televised from structure to structure as described in the City of La Crosse Standard Procedures. Dewatering shall be incidental to the pipe laying and is described in the City of La Crosse Standard Procedures.
- (4) Pipe laying must be complete with backfilling and cleanup operations completed or being continued without interruption as a positive requirement before permission is granted to continue excavating and pipe laying in the next block. Cleanup shall include removal of all excess materials, pipe and equipment from the entire street right of way, including boulevards and sidewalks. Backfilling must be completed as specified to allow the Street Department or pavement contractor to repair the street as soon as possible after pipe laying is complete. Backfilling shall be incidental to the pipe laying and is described in the City of La Crosse Standard Procedures.

205.3.4 Replace

- (1) This item shall be used for replacing existing pipe with new PVC or RCP pipe when the existing pipe is located within the same trench. Removal of existing storm sewer pipe shall be incidental to this item.
- (2) Connecting fittings shall be incidental to this item.
- (3) The Contractor shall follow construction methods for Pipe Laying when laying new pipe.



Engineering Department

400 La Crosse St., La Crosse, WI 54601 • (608) 789-7505 • Fax: (608) 789-8184
<http://www.cityoflacrosse.org>

205.4 Measurement

- (1) The department will measure remove or abandon storm sewer pipe by the lineal foot (LF) successfully removed and restored or abandoned. The measurement will be based on the plan quantities or field markings by the engineer.
- (2) The department will measure each lineal foot (LF) of pipe furnished and successfully installed for all new and replaced storm sewer pipe. The measurement will be made on the road from edge of structure to edge of structure.

205.5 Payment

The department will pay for the measured quantity at the contract unit price under the following bid item:

ITEM NUMBER	DESCRIPTION	UNIT
205.01-.04	Remove Storm Sewer Pipe (Depth)	LF
205.05-.08	Abandon Storm Sewer Pipe (Depth)	LF
206.01-.06	New PVC SDR-26 Storm Sewer (size)	LF
206.07-.10	New PVC PS 115 Storm Sewer (size)	LF
206.11-.16	New PVC SDR-35 Storm Sewer (size)	LF
206.17-.20	New PVC PS 46 Storm Sewer (size)	LF
207.01-.06	Replace PVC SDR-26 Storm Sewer (size)	LF
207.07-.10	Replace PVC PS 115 Storm Sewer (size)	LF
207.11-.16	Replace PVC SDR-35 Storm Sewer (size)	LF
207.17-.20	Replace PVC PS 46 Storm Sewer (size)	LF
208.01-.15	New Class 3 RCP Storm Sewer (size)	LF
209.01-.15	New Class 4 RCP Storm Sewer (size)	LF
210.01-.15	New Class 5 RCP Storm Sewer (size)	LF
211.01-.15	Replace Class 3 RCP Storm Sewer (size)	LF
212.01-.15	Replace Class 4 RCP Storm Sewer (size)	LF
213.01-.15	Replace Class 5 RCP Storm Sewer (size)	LF

205.6 Testing, Acceptance, & Maintenance

- (1) Each pipe shall be carefully inspected and those not meeting the specifications shall be rejected. No pipe shall be laid except in the presence of the Engineer or his authorized inspector, and the Engineer may order the removal and relaying of any pipe improperly installed.
- (2) The cost of all testing by the Contractor shall be included in the unit price for the various size and type of sewer pipe installed. For all tests, the Contractor shall install, backfill and clean all sewer mains and any related appurtenances prior to performing the test.

205.4.1 Televising

- (1) At the completion of the utility portion of the project, prior to paving operations, the contractor shall provide the City with a digital video record of all new and replaced storm sewers installed. Final acceptance of the new and replaced sewers shall be based on the review of the video record. The televising contractor shall be regularly engaged in televising of sewers and shall provide all equipment necessary to provide the digital video record of the sewers installed.
- (2) The contractor shall televise all sewer pipe between structures when more than 20 feet of the pipe length has been replaced or as directed by the Project Engineer.
- (3) The video equipment used shall be designed specifically for televising sewer and shall have on-board lighting, may be either self-propelled or towed. The camera shall be capable of turning and rotating 360 degrees and shall have



Engineering Department

400 La Crosse St., La Crosse, WI 54601 • (608) 789-7505 • Fax: (608) 789-8184
<http://www.cityoflacrosse.org>

magnification to provide a close-up view of the full interior of the sewer pipes including the crown regardless of pipe diameter. The contractor shall provide an on-site heated and cooled enclosure and shall permit the televising to be observed by a representative of the City.

- (4) The Contractor shall lightly clean the sewer pipes prior to televising. No material shall be passed from section to section. All sludge, dirt, sand, rock, grease, roots, and other solid or semi-solid materials resulting from the cleaning operation shall be removed at the upstream or downstream manhole of the section being cleaned. All solids or semi-solids resulting from the cleaning shall be removed from the site by the Contractor on a daily basis. The contractor is responsible for disposing of any materials removed during the cleaning operations.
- (5) The digital video record shall be a digital file in a mpeg format. The file shall show a continuous video of each length of sewer televised. The video shall include the following:
 - A. Date and time when the recording was made.
 - B. Name of the street or location of the sewer including cross streets.
 - C. Type and size of sewer televised.
 - D. Distance from manhole to manhole.
 - E. Distance from manhole to each sewer wye or tap, and angle at which the wye or tap is connected to the sewer pipe.
 - F. Before starting televising the contractor shall provide a sample video recording to the Engineer to confirm that the format is acceptable.

205.4.2 Mandrel Test

- (1) **At the request of the Engineer**, pipe 12 inches and larger shall be tested for acceptance with an approved go-no-go mandrel not less than thirty days after the pipe has been installed, the backfill compacted, and other underground utilities within close proximity (such as water main) have been installed and backfilled but before paving is constructed. For acceptance, the mandrel must pass through the entire section between sewer access structures in one pass when pulled by hand without the use of excessive force.
- (2) The Contractor shall furnish the equipment and labor for making this acceptance test. The mandrel shall be of a shape similar to that of a true circle enabling the gauge to pass through a satisfactory pipeline with little or no resistance. The mandrel shall be of a design to prevent it from tipping from side to side and to prevent debris build-up from occurring between the channels of the adjacent fins or legs during operation. Each end of the core of the mandrel shall have fasteners to which the pulling cables can be attached. The mandrel shall have nine various sized fins or legs of appropriate dimensions for various diameter pipes. Each fin or leg shall have a permanent marking that states its designated pipe size and percent deflection allowable. The diameter of the mandrel shall be equal to ninety-two point five (92.5) percent of the base inside diameter of the pipe. The Contractor shall furnish the engineer a table showing the base inside diameter and the seven point five (7.5) percent deflection mandrel dimension for each pipe diameter called for in the plans. The base inside diameter shall be the minimum pipe inside diameter derived by subtracting the statistical tolerance package (defined below) from the pipe's average inside diameter. 9 point mandrels shall be used by the Contractor for testing:

Nominal Size	Mandrel Size
12 inch Diameter	11.04 inches
15 inch Diameter	13.80 inches
18 inch Diameter	16.57 inches
24 inch Diameter	22.08 inches
30 inch Diameter	27.60 inches
36 inch Diameter	33.12 inches

- (3) Any section of completed pipe failing to pass this deflection test shall be replaced and retested at the Contractor's expense. If base course, pavement, concrete, landscaping, seeding, matting, curb gutter, sidewalk, or driveways



Engineering Department

400 La Crosse St., La Crosse, WI 54601 • (608) 789-7505 • Fax: (608) 789-8184
<http://www.cityoflacrosse.org>

have been placed over the pipe, removal and replacement of those items shall also be done at the contractor's expense.

205.4.3 Load-Bearing Test

- (1) ***At the request of the Engineer***, the Contractor shall provide plant performed load-bearing test results. Pipe lot acceptance shall conform to ASTM C 76 requirements.



220-STORM SEWER STRUCTURE CONSTRUCTION

220.1 General Description

- (1) This section describes removing, replacing, or installing new storm sewer manholes and catch basins. The materials furnished and installed shall conform to the requirements specified herein for the type and size of material named in the plan.

220.2 Materials

- (1) Base materials and backfilling materials shall conform to City of La Crosse Standard Procedures.
- (2) Unless otherwise directed by the Engineer, all structures shall be unloaded at the point of delivery, and hauled to and distributed at the site of the work by the Contractor. The materials shall be at all times handled with care to avoid damage. The material shall not be dropped or bumped against the ground, other pipe and accessories already on the ground, or any other object on the ground.
- (3) All materials shall be stored within the roadway limits (back of curb to back of curb).
- (4) All structures to be installed shall include 3 to 10 foot long PVC pipe (SDR 35 or SDR 26) outside of the structure to provide adequate room for connections. The pipe shall conform to City of La Crosse Standard Procedures.
- (5) Mortar specified in the plans shall meet the requirements for Type "M" mortar of the property specification of ASTM Designation C-270. Mortar shall consist of a mixture of clean mason sand, water, and air-entraining cementitious materials.
- (6) Flexible coupling or connection of pipe to the structure shall use FERNCO product or Engineer approved equal. The coupling shall be manufactured to match the outside diameter of each pipe and to align the pipe inverts. The flexible coupling material shall be designed for use on sewers. The material shall be resistant to chemicals, bacteria, fungus, and gases. The coupling shall be furnished with stainless steel compression bands.
- (7) Unless otherwise specified, references to various standard specifications and test methods shall be understood to mean the specification or test method which is current on the date of awarding of bid.

220.2.1 Removal

- (1) The existing storm sewer manhole may consist of red brick, block or precast construction. All manhole components are to be removed and discarded off site except the casting is to be salvaged for the City of La Crosse Sewer Department.

220.2.2 Manhole

- (1) The pre-cast manhole shop drawing and delivered structure shall be approved by the Project Engineer prior to installation.
- (2) Manholes shall be of precast concrete only. Precast manhole shall be of the size and type shown in the details.
- (3) Precast manholes shall be of reinforced concrete and shall conform to the specifications of Precast Reinforced Concrete Manhole Sections, ASTM C 478.
- (4) All new or replaced manholes shall be constructed without steps. Cutting of steps out of new manhole sections is prohibited.
- (5) Pick holes shall be sealed on the inside and the outside of the precast structure prior to backfilling the excavation.
- (6) Each precast structure on the plan shall be custom manufactured with factory-made cutouts for storm sewer connections. Cutouts shall Not extend into the groove of the bottom section or barrel section. There shall be a minimum of twelve (12) inches of the inside wall of the precast structure present between the cutouts for the pipes. A minimum of two (2) inches of the precast structure must be present between the top of the knockout and the bottom of the adjustment rings. No removal of the precast structure above the precast knockout will be allowed.



- (7) All manhole joints except the upper most joint between the frame and top precast ring shall be free of concrete mortar. Concrete mortar shall be allowed at this joint up to a thickness of $\frac{3}{4}$ inch to achieve final plan grade of the casting. All other joints shall be sealed with flexible butyl rubber gaskets or rope.
- (8) All pipes entering a manhole shall be cut to the proper length. The pipe shall be cut by sawing or other method approved by the Engineer. Breaking the pipe to length with a hammer will not be allowed. The pipe shall be cut so the point in the pipe, which extends least into the manhole or catch basin, is flush with the inside wall of the manhole or catch basin, plus or minus one inch. A flexible boot shall be used to connect the pipe to the manhole for all PVC pipe connections. When plans or specifications request RCP pipe connection, openings around the pipe shall be sealed with brick and mortar and the inside and outside surface coated with mortar.
- (9) All Manhole structures over 48" inside diameter shall be constant diameter to the top of the structure. The structure top shall have a concrete top with a 27" diameter centered opening for the manhole casting.

220.2.3 Class "W" Manhole

- (1) Class "W" manholes shall be waterproofed on the exterior with a coating of coal tar epoxy or other approved bituminous waterproof coating.
- (2) Manhole joint seal shall be minimum of nine (9) inches wide. The seal shall consist of flexible rubberize seal conforming to ASTM C923 held in place with stainless steel compression bands or butyl adhesive tape conforming to ASTM C877. Products are subject to pre-approval by the Engineer.

220.2.4 Catch Basin

- (1) The pre-cast catch basin shop drawing and delivered structure shall be approved by the Project Engineer prior to installation.
- (2) Catch basins and inlets shall be of precast concrete only. Precast structure shall be of the size and type shown in the details. No square WisDOT style catch basins shall be allowed.
- (3) Precast catch basins shall be of reinforced concrete and shall conform to the specifications of Precast Reinforced Concrete Manhole Sections, ASTM C 478.
- (4) All new or replaced catch basins shall be constructed without steps. Cutting of steps out of new manhole sections is prohibited.
- (5) Pick holes shall be sealed on the inside and the outside of the precast structure prior to backfilling the excavation.
- (6) Each precast structure on the plan shall be custom manufactured with factory-made cutouts for storm sewer connections. Cutouts shall Not extend into the groove of the bottom section or barrel section. There shall be a minimum of twelve (12) inches of the inside wall of the precast structure present between the cutouts for the pipes. A minimum of two (2) inches of the precast structure must be present between the top of the knockout and the bottom of the adjustment rings. No removal of the precast structure above the precast knockout will be allowed.
- (7) Manhole inverts shall be poured with 3500-psi concrete (minimum 28-day strength) with $\frac{3}{4}$ inch maximum aggregate size. Inverts shall be filleted to provide a smooth flow line through the manhole, with the radius of the "trough" formed matching that of the pipe. The fillets shall extend half way up the pipe on each side of each pipe and slope upward to the sides of the manhole. The invert shall be poured directly on the concrete base of the manhole. Where the invert elevation is below the ground water table, the minimum thickness of the invert shall not be less than 4 inches.
- (8) All catch basin joints except the upper most joint between the frame and top precast ring shall be free of concrete mortar. Concrete mortar shall be allowed at this joint up to a thickness of $\frac{3}{4}$ inch to achieve final plan grade of the casting. All other joints shall be sealed with flexible butyl rubber gaskets or rope.
- (9) All pipes entering a catch basin shall be cut to the proper length. The pipe shall be cut by sawing or other method approved by the Engineer. Breaking the pipe to length with a hammer will not be allowed. The pipe shall be cut so the point in the pipe, which extends least into the manhole or catch basin, is flush with the inside wall of the



manhole or catch basin, plus or minus one inch. When plans or specifications request RCP pipe connection, openings around the pipe shall be sealed with brick and mortar and the inside and outside surface coated with mortar.

- (10) All catch basins shall be constructed with a minimum 18" sump below the invert elevation of the discharge pipe.

220.2.5 Concrete Rings

- (1) Concrete adjusting rings shall be provided with reinforcement.
- (2) Concrete rings shall be of standard size of 2 or 4-inch thickness at the following standard-sized diameter rings.
 - A. Manhole – 27" diameter opening
 - B. Catch Basin A – 30" x 36" opening
 - C. Catch Basin B – 22" x 27" opening
- (3) Concrete Mortar used between top ring and casting shall follow ATM C-270 Specification.
- (4) All other joints shall be sealed with flexible butyl rubber gaskets or rope.

220.2.6 Concrete Top

- (1) Concrete Top shall be of precast concrete and concentric top only. Precast structure shall be of the size and type shown in the details.
- (2) Precast concrete top shall be of reinforced concrete and shall conform to the specifications of Precast Reinforced Concrete Manhole Sections, ASTM C 478.
- (3) The Concrete top joint shall be free of concrete mortar. Concrete mortar shall be allowed at the joint between the concrete top and the casting up to a thickness of $\frac{3}{4}$ inch to achieve final plan grade of the casting. All other joints shall be sealed with flexible butyl rubber gaskets or rope.

220.2.7 Concrete Cone

- (1) Concrete Cone shall be of precast concrete only. Precast structure shall be of the size and type shown in the details. Concrete cone shall be concentric type only.
- (2) Precast concrete cone shall be of reinforced concrete and shall conform to the specifications of Precast Reinforced Concrete Manhole Sections, ASTM C 478.
- (3) The Concrete cone joint shall be free of concrete mortar. Concrete mortar shall be allowed at the joint between the concrete top and the casting up to a thickness of $\frac{3}{4}$ inch to achieve final plan grade of the casting. All other joints shall be sealed with flexible butyl rubber gaskets or rope.

220.2.8 Casting

- (1) Existing Castings shall be salvaged, set aside in an easily accessible area to be reused or delivered to the municipal storage unit. All new castings shall be provided by the City of La Crosse Sewer Department if needed. The Contractor shall provide new castings if specified in the Specifications, plans, or as requested by the Engineer.
- (2) The castings for manholes, catch basins, and inlets shall be in accordance with the designs, dimensions, and details shown on the Standard Detail Drawings for the installation named, unless otherwise specified. Frames and covers for manholes and catch basins shall be machined and fitted so that rocking and chattering will be eliminated.
- (3) Gray iron castings used in the work shall conform to the requirements of the Specifications for Gray Iron Castings, ASTM A 48, Class 30.
- (4) If existing catch basin casting is reused, new header bolts shall be used. New header bolts shall be stainless steel and shall be provided by the City of La Crosse Sewer Department.
- (5) The following Neenah Foundry castings are acceptable for City construction and are further detailed in the Standard Detail Drawings. Substitutions shall be approved by the Engineer prior to delivery to the job site.



Engineering Department

400 La Crosse St., La Crosse, WI 54601 • (608) 789-7505 • Fax: (608) 789-8184
<http://www.cityoflacrosse.org>

City of La Crosse Standards			
Type	Catalog #	Component #	Notes
Inlet: Type B	R-3234-B1	Frame 3234-0005 Grate 3234-0003 Box 3234-0012	"DUMP NO WASTE DRAINS TO RIVER" STAINLESS STEEL HARDWARE
Inlet: Type A	R-3246-A	Frame 3246-2001 Grate 3246-3002 Box 3290-0043	"DUMP NO WASTE DRAINS TO RIVER" STAINLESS STEEL HARDWARE
Inlet: Standard Gutter/Drive over	R-3350	Frame 3350-0001 Grate 3350-0002	CONCAVE
Inlet: Small Gutter/Drive over	R-3205	Frame 3205-0001 Grate 3205-0002	CONCAVE
Inlet: Beehive	R-2560-E	Frame 1050-2000 Grate 3290-0009	
Manhole Storm	R-1670-A	Frame 1670-0004 Lid 1670-0349 Grate 2500-002	T-SEAL/NO ROCK "STORM" LABEL LID
Manhole: 4" Storm	R-1689	Frame 1689-2301 Lid 1689-1550-0050 Grate 2050-0003	T-SEAL/NO ROCK ONLY TO BE USED WITH THE APPROVAL OF THE SEWER SUPERINTENDENT

220.3 Construction Methods

- (1) The contractor shall be responsible for the accurate transfer of all construction alignment and grades from the primary line and grade as established by the Engineer. In addition, the Contractor shall supply, at his own cost, and have available on site, the proper surveying equipment for the transfer of grades. If a laser is used during piping, a transit will be required to establish the alignment.
- (2) The Contractor shall follow City of La Crosse Standard Procedures for site preparation and excavation.
- (3) The Contractor shall place minimum of six (6) inches of bedding material prior to placement of manhole or catch basin structure.
- (4) The Contractor shall construct manhole and catch basin structures at the location and grade conforming to the requirements as shown on the Plans and Details.
- (5) Excavation shall be limited to the size required for the proposed structure. All undesirable material which cannot adequately support the structure shall be removed below the normal bottom and replaced with crushed stone.
- (6) Structures shall be backfilled in one-foot lifts, and compacted with special mechanical compactors as approved by the Engineer, to achieve 95% of the modified proctor density.
- (7) Total height adjustment shall be a minimum of three (3) inches and a maximum of nine (9) inches.
- (8) The Contractor shall use appropriately sized PVC SDR 35 / PVC SDR 26 stub outs (3-10 feet long) and Fernco flexible connections (or approved equal) for all connections to the existing sewer mains or leads. Connections shall be included in the price of the new or replaced structure.

220.3.1 Removal

- (1) Removal limits are as shown on plans and/or by field markings done by engineer. Any removals or damage caused beyond this point without the engineer's permission will be the responsibility of the contractor to replace at their expense. Casting shall be set aside in an easily accessible area or delivered to municipal storage unit.
- (2) Removals shall include the following but not limited to:



- A. Equipment to facilitate removal and transport of manhole and soil.
- B. Removal of manhole and offsite disposal.
- C. Capping remaining pipe if needed.
- D. Additional Backfill material if needed.

220.3.2 Manhole

- (1) The proposed manhole elevations are shown on the project plans. Actual manhole build shall be less the casting and adjusting rings as shown on the details. This will allow for any field adjusting as deemed necessary by the Engineer.
- (2) Manhole casting final adjustment shall utilize City of La Crosse Standard Procedures Core and Pour Finishing, during full pavement replacement operations.
- (3) Manhole casting final adjustment shall utilize City of La Crosse Standard Procedures Adjust Structure, during pavement overlay operations.
- (4) Manhole casting shall be held to a maximum of 3/8" below pavement surface.

220.3.3 Class W Manhole

- (1) Manholes may be designated as class "W" in areas of known high water or designated by the Engineer. Class "W" manholes' inlet and outlet pipes shall be joined to the manhole with a gasketed flexible watertight connection or any watertight connection arrangement that allows differential settlement of the pipe and manhole wall.
- (2) The joints between the manhole casting and cone section or flat-top shall be sealed with an internal or external flexible rubber seal. An external flexible rubber seal shall be utilized on all newly constructed manholes. Internal flexible rubber seals shall only be used on sewer renovation projects with pre-approval by the Engineering Department. A bead of butyl rubber caulk shall be applied to the lower sealing surface of the rubber sleeve to fill minor irregularities.
- (3) All manhole joints except the upper most joint between the casting and top precast ring shall be free of concrete mortar. Concrete mortar shall be installed at this joint up to a thickness of 3/4 inch to achieve final plan grade of the casting. All other joints shall be sealed with flexible butyl rubber gaskets or rope.
- (4) Manhole casting shall be held to a maximum of 3/8" below pavement surface.

220.3.4 Catch Basin

- (1) In order to maintain functional purpose of catch basins, in place at the time a storm sewer project is begun, as well as to avoid unnecessary expenditures on the part of the City in the closing, repair or resurfacing of an intersection, the Contractor shall proceed as follows in the scheduling of the work.
 - A. Catch basin leads to the new sewer must be completed at each intersection during initial closing of such intersection and before a new intersection is closed for construction.
 - B. Where catch basin leads are damaged that subsequently are to be "dead", the new leads essential are to be installed as soon as sufficient new main is available for such installation.
 - C. Where catch basin leads and basin structures are planned, but do not exist when construction is started, scheduling of such installation shall depend upon the decision of the City with respect to necessity of opening the intersection and to avoid unnecessary expense in repair or replacing the surfacing of the street.
- (2) Casting shall be installed to the grade shown on the plans or as directed by the Engineer or City Inspector. Casting shall be installed 1/4" below final grade prior to and separate from the pouring of the concrete curb and gutter. It is expected and required that six feet of curb and gutter on either side of the inlet shall be poured by hand.

220.3.5 Concrete Rings

- (1) All rings are to be installed per City of La Crosse Standard Detail.
- (2) Contractor shall use the least number of rings possible to bring casting to within twelve (12) inches of final grade.
- (3) Concrete rings shall be separated with flexible butyl rubber gaskets or rope.



Engineering Department

400 La Crosse St., La Crosse, WI 54601 • (608) 789-7505 • Fax: (608) 789-8184
http://www.cityoflacrosse.org

- (4) A minimum thickness of ½ inch of mortar shall be placed and maintained between the adjusting rings and the casting.
- (5) The remaining 12 inches of adjustment (which includes the casting) shall be part of core and pour finishing or adjust structure. These items are described in the City of La Crosse Standard Procedures.
- (6) No inlet or manhole casting shall be adjusted without the Engineer or City Inspector present.
- (7) Contractor shall allow city inspector a visual inspection of the rings prior to placing casting. Uninspected rings will not be measured for payment.

220.3.6 Replacement

- (1) This item shall be used when a structure is being replaced in a location less than 5 feet from the original location.
- (2) This item shall follow construction methods for removal and new installation. This item shall also include removal of existing storm sewer structure. Removal of existing structure shall be incidental to this item.
- (3) Existing Casting shall be salvaged. If existing casing is reused, new header bolts shall be used.

220.4 Measurement

The department will measure each (EA) storm sewer structure successfully removed or furnished and installed.

220.5 Payment

The department will pay for the measured quantity at the contract unit price under the following bid item:

ITEM NUMBER	DESCRIPTION	UNIT
220.01-.04	Remove Storm Sewer Manhole (Depth)	EACH
221.01-.04	New 48" I.D. Standard Pre-Cast Concrete Manhole (Depth)	EACH
221.05-.08	New 60" I.D. Standard Pre-Cast Concrete Manhole (Depth)	EACH
221.09-.12	New 72" I.D. Standard Pre-Cast Concrete Manhole (Depth)	EACH
221.13-.16	New 84" I.D. Standard Pre-Cast Concrete Manhole (Depth)	EACH
221.17-.20	New 96" I.D. Standard Pre-Cast Concrete Manhole (Depth)	EACH
222.01-.04	Replace 48" I.D. Standard Pre-Cast Concrete Manhole (Depth)	EACH
222.05-.08	Replace 60" I.D. Standard Pre-Cast Concrete Manhole (Depth)	EACH
222.09-.12	Replace 72" I.D. Standard Pre-Cast Concrete Manhole (Depth)	EACH
222.13-.16	Replace 84" I.D. Standard Pre-Cast Concrete Manhole (Depth)	EACH
222.17-.20	Replace 96" I.D. Standard Pre-Cast Concrete Manhole (Depth)	EACH
223.01	Remove Catch Basin	EACH
224.01-03	New Catch Basin (Type)	EACH
225.01-03	Replace Catch Basin (Type)	EACH

220.6 Testing, Acceptance, & Maintenance

- (1) The Engineer shall review shop drawings for all new manholes, catch basins, and inlets. The Engineer shall have five (5) business days to review and provide the Contractor with any required changes or modifications. The Contractor shall make the required changes at no additional cost. The precast shop drawing and delivered structure shall be approved by the Engineer prior to installation.



230-REPAIR/MODIFY EXISTING STORM SEWER STRUCTURE

230.1 General Description

- (1) The following items are to be used when modifying or repairing existing structures or connecting new pipe to existing structures.

230.2 Materials

- (1) All equipment and materials used for repairs or modification to existing storm sewer structures shall conform to City of La Crosse Standard Procedures.

230.2.1 Connect to Existing

- (1) The existing storm sewer manhole should be precast construction. The new connection pipe type may be PVC, RCP, or approved alternate material. Any material necessary to make the connection shall comply with the City of La Crosse Standard Procedures.

230.2.2 Adjust Structure

- (1) The contractor shall provide all necessary labor, equipment, and materials to adjust all manhole castings to a depth of 12" from finished grade. Any material necessary to bring casting to final grade shall comply with City of La Crosse Standard Procedures.

230.2.3 Replace Rings

- (1) The City generally uses three different standard-sized diameter ring sizes on its structures. The contractor shall furnish and install up to approximately 1 foot of rings per structure, unless otherwise noted on the plans.
 - A. Manhole – 27" diameter opening
 - B. Catch Basin A – 30"x36" opening
 - C. Catch Basin B – 22"x27" opening
- (2) Rings are available in 2 inch and 4 inch thicknesses. If oversized diameter rings are required at the upper portion of any manholes, the City will furnish the oversized diameter rings.

230.3 Construction Methods

230.3.1 Connect to Existing

- (1) Connecting pipe up to 12" diameter PVC

In locations where a new storm sewer line is proposed or an existing storm sewer line is to be replaced with a larger diameter pipe, the Contractor shall core drill the existing manhole at the proposed line, grade, and diameter indicated on the plans or in the specifications. The diameter of the hole cored shall be sized to accept a flexible pipe-to-manhole boot. The contractor shall core the manhole 4" larger than the connecting pipe diameter and install a boot.

- (2) Connecting another pipe material or larger diameter PVC

The Contractor shall cut a square opening using a saw. The opening around the pipe shall be sealed with brick and mortar and the inside and outside surface coated with mortar.

230.3.2 Adjust Structure

- (1) Adjusting manhole and inlet structures shall be considered incidental to the appropriate manhole, inlet, and catch basin work as specified in other sections when constructing new or replaced structure with the same contract. This item shall be called out in the project plans and used when modifying an existing structure.
- (2) Existing Castings shall be salvaged, set aside in an easily accessible area to be reused or delivered to the municipal storage unit.
- (3) The Contractor shall provide necessary concrete rings, flexible butyl rubber gaskets or rope, and mortar.



- (4) If existing casting is reused with an inlet or catch basin structure, new stainless steel bolts shall be used. New header bolts shall be provided by the City of La Crosse Sewer Department.
- (5) All new castings shall be provided by the City of La Crosse Sewer Department if necessary. The Contractor shall provide new castings if specified in the Specifications, plans, or as requested by the Engineer that shall conform to the City of La Crosse Standard Procedure.
- (6) Final casting placement shall conform to the finished crown of the road.

230.3.3 Replace Rings

- (1) Ring adjustment shall be considered incidental to the appropriate manhole, inlet, or catch basin work as specified in other sections when constructing new or replaced structure with the same contract. This item shall be called out in the project plans and used when modifying an existing structure.
- (2) Replace rings shall be measured for payment as noted on the plans.
- (3) All rings are to be installed per standard detail. Reference City of La Crosse Standard Procedures for the composition of the mortar to be used. If existing conditions are different than our standard details, this must be brought up with the Engineer before continuing.
- (4) Ring replacements are to be made with the fewest number of rings possible.
- (5) Ring replacements are to conform to the City of La Crosse Standard Procedures.
- (6) Existing Castings shall be salvaged, set aside in an easily accessible area to be reused or delivered to the municipal storage unit.
- (7) The Contractor shall provide necessary concrete rings, flexible butyl rubber gaskets or rope, and mortar.
- (8) If existing casting is reused with an inlet or catch basin structure, new header bolts shall be used. New stainless steel header bolts shall be provided by the City of La Crosse Sewer Department.
- (9) All new castings shall be provided by the City of La Crosse Sewer Department if necessary. The Contractor shall provide new castings if specified in the Specifications, plans, or as requested by the Engineer that shall conform to the City of La Crosse Standard Procedure.
- (10) Final casting placement shall conform to the finished crown of the road.

230.3.4 Replace Cone

- (1) Concrete Cone Replacement shall be considered incidental to the appropriate manhole work as specified in other sections when constructing new or replaced structure with the same contract. This item shall be called out in the project plans and used when modifying an existing structure.
- (2) This item shall include any material and necessary tasks to excavate, replace cone, backfill, and bring casting to final grade. Any rings required to raise the casting to final grade shall be included in this item. Removal of existing cone shall be incidental to this item.
- (3) Existing Castings shall be salvaged, set aside in an easily accessible area to be reused or delivered to the municipal storage unit.
- (4) The Contractor shall provide necessary concrete rings, flexible butyl rubber gaskets or rope, and mortar.
- (5) All new castings shall be provided by the City of La Crosse Sewer Department if necessary. The Contractor shall provide new castings if specified in the Specifications, plans, or as requested by the Engineer that shall conform to the City of La Crosse Standard Procedure.
- (6) Final casting placement shall conform to the finished crown of the road.

230.3.5 Replace Top

- (1) Concrete Top Replacement shall be considered incidental to the appropriate manhole, inlet, or catch basin work as specified in other sections when constructing new or replaced structure with the same contract. This item shall be called out in the project plans and used when modifying an existing structure.
- (2) This item shall include any material and necessary tasks to excavate, replace top, backfill, and bring casting to final grade. Any rings required to raise the casting to final grade shall be included in this item.



Engineering Department

400 La Crosse St., La Crosse, WI 54601 • (608) 789-7505 • Fax: (608) 789-8184
<http://www.cityoflacrosse.org>

- (3) Existing Castings shall be salvaged, set aside in an easily accessible area to be reused or delivered to the municipal storage unit.
- (4) The Contractor shall provide necessary concrete rings, flexible butyl rubber gaskets or rope, and mortar.
- (5) If existing casting is reused with an inlet or catch basin structure, new stainless steel header bolts shall be used.
- (6) All new castings shall be provided by the City of La Crosse Sewer Department if necessary. The Contractor shall provide new castings if specified in the Specifications, plans, or as requested by the Engineer that shall conform to the City of La Crosse Standard Procedure.
- (7) Final casting placement shall conform to the finished crown of the road.

230.4 Measurement

- (1) The department will measure each (EA) Storm Manhole connection successfully completed.
- (2) The department will measure each (EA) Storm structure successfully adjusted to final elevation.
- (3) The department will measure inch (IN) of height of rings replaced and acceptably completed. Contractor shall allow city inspector a visual inspection of the rings prior placing casting. Uninspected rings will not be measured for payment.
- (4) The department will measure each (EA) cone successfully furnished and replaced.
- (5) The department will measure each (EA) concrete top successfully furnished and replaced.

230.5 Payment

The department will pay for the measured quantity at the contract unit price under the following bid item:

ITEM NUMBER	DESCRIPTION	UNIT
230.01	Connect to Existing Storm Manhole (PVC up to 12")	EACH
230.02	Connect to Existing Storm Manhole (Other pipe type/size)	EACH
230.03	Connect to Existing Storm Catch Basin (PVC up to 12")	EACH
230.04	Connect to Existing Storm Catch Basin (Other pipe type/size)	EACH
231.01	Adjust Existing Manhole Structures to Final Elevation	EACH
231.02	Adjust Existing Catch Basin to Final Elevation	EACH
232.01	Replace Rings (Manhole)	IN
232.02	Replace Rings (Catch Basin Type A)	IN
232.03	Replace Rings (Catch Basin Type B)	IN
233.01	Replace Manhole Cone	EACH
233.02	Replace Manhole Cone (City Furnished)	EACH
233.03	Replace Catch Basin Cone	EACH
233.04	Replace Catch Basin Cone (City Furnished)	EACH
234.01	Replace Pre-Cast Concrete Top	EACH
234.02	Replace Pre-Cast Concrete Top (City Furnished)	EACH

230.6 Testing, Acceptance, & Maintenance

N/A



240-BIORETENTION CELLS (BIO-CELLS)

240.1 General Description

- (1) Bio-cells shall be installed per plans and these Standard Procedures. Contractor shall provide all materials, labor, services, and appurtenances necessary for the completion of the bio-cells. Excavation, protection of exposed native soil, and placement of engineered soil for the bio-cells shall be per Wisconsin Department of Natural Resources Conservation Practice Standard "Bioretention for Infiltration (1004) - Section V. C. Construction Sequencing and Oversight."

240.2 Materials

240.2.1 Engineered Soil

- (1) The engineered soil used to backfill the Bio-Cell shall be a mixture of sand, compost and topsoil that will support biological and plant growth. The engineered soil shall meet the following requirements:

Component	By Volume	Material Specification
Sand (SiO ₂)	40%	USDA Course Sand (0.02-0.04 In.) ASTM C33-(Fine Aggregate Concrete Sand) Wis DOT 501-(Fine Concrete Sand) Minimum 97% SiO ₂
Topsoil	30% - 20%	(see below)
Compost	30% - 40%	WisDNR Spec. S100 Compost (attached)

- (2) The sand shall be a minimum of 97% SiO₂. Other materials such as calcium carbonate, dolomite, or other stone dust are not acceptable. The sand is to be washed and free of dust and fines, and dried prior to mixing.
- (3) Topsoil shall be a USDA classified sandy loam, loamy sand or of loam texture. Topsoil shall be evaluated by a soil test professional and a report of the evaluation submitted to the Engineer. Topsoil shall be imported.

240.2.2 Grass Seed Mixture

- (1) Grass shall be La Crosse Seed Company Eco-Tall Native Grass Mix. Seed shall be applied and evenly distributed on the entire bio-cell surface with adequate even coverage at a rate of 5 pounds per 1000 square feet. Fertilizer shall be included in the price of seed and applied as necessary per seed company recommendations.
- (2) In addition, the following plugs shall be planted around the upper perimeter.

Common Name	Size	Count	Spacing
Wiltoni Blue Rug Juniper	#5 Cont.	12	72" o.c.
Catmint Walkers Law	1 gallon	36	24" o.c.

240.2.3 Erosion Protection

- (1) Erosion protection shall use a Class 1 Type A erosion control blanket stitched with degradable thread between photodegradable polypropylene top and bottom nets. Blanket shall be listed in the Wisconsin Produce Acceptability List (PAL). Points of concentrated flow shall be protected with type R geofabric and WisDOT type Medium rip-rap sized as follows:

Diameter in inches	VOLUME OCCUPIED BY STONES
>20	>25 >30 0%



14 – 16	10% - 14%
11 – 14	15% - 21%
5 – 11	20% - 28%
<5	5% - 7%
<1	2% or less

240.3 Construction Methods

- (1) Excavation, protection of exposed native soil, and placement of engineered soil for the bio-cells shall be per Wisconsin Department of Natural Resources Conservation Practice Standard “Bioretention for Infiltration (1004) – Section V. C. Construction Sequencing and Oversight.

240.3.1 Engineered Soil

- (1) The minimum depth of the engineered soil shall be 3 feet. The surface and bottom shape of the engineered soil shall be as directed by engineer and as near to plan detail as practicably allows. However, native soil stability for exposed side slopes and underground obstructions may result in changes to the final shape and size. The engineer must inspect and approve final hole prior to placement of any engineered soil.
- (2) Final surface slopes, from back of curb and front of walk, down to the bottom of the BioCell shall not exceed 3:1 (3 horizontal to 1 vertical).
- (3) Due to the minimum compaction during engineered soil placement Additional natural compaction will occur after soil is placed.
- (4) After the placement soil the contractor should induce natural compaction by flooding the BioCell (minimum 6 inches of water over entire bio-cell area) or allowed 2 week period for settling and natural compaction; then return and furnish and install additional soil mix to meet design grades and slopes. Alternately, the contractor can over fill initially, and remove material to reach design grades after natural compaction has occurred.

240.3.2 BioCell Construction

- (1) A person trained and experienced in the construction, operation and maintenance of infiltration devices shall be responsible for construction of the device. The following apply:
 - A. Construction Site Stabilization – Construction site runoff from disturbed areas shall not be allowed to enter the bioretention device. Runoff from pervious areas shall be diverted from the device until the pervious areas have undergone final stabilization.
 - B. Suitable Weather – Construction shall be suspended during periods of rainfall or snowmelt. Construction shall remain suspended if ponded water is present or if residual soil moisture contributes significantly to the potential for soil smearing, clumping or other forms of compaction.
 - C. Compaction Avoidance – Compaction and smearing of the soils beneath the floor and side slopes of the bioretention area, and compaction of the soils used for backfill in the soil planting bed, shall be minimized. During site development, the area dedicated to the bioretention device shall be cordoned off to prevent access by heavy equipment. Acceptable equipment for constructing the bioretention device includes excavation hoes, light equipment with turf type tires, marsh equipment or wide-track loaders.
 - D. Compaction Remediation – If compaction occurs at the base of the bioretention device, the soil shall be refractured to a depth of at least 12 inches. If smearing occurs, the smeared areas of the interface shall be corrected by raking or roto-tilling.
 - E. Placement and Settling of Engineered Soil – The following apply:
 1. Prior to placement in the bioretention device, the engineered soil shall be premixed and the moisture content shall be low enough to prevent clumping and compaction during placement.
 2. The engineered soil shall be placed in multiple lifts, each approximately 12 inches in depth.



- 3. Steps may be taken to induce mild settling of the engineered soil bed as needed to prepare a stable planting medium and to stabilize the ponding depth. Vibrating plate-style compactors shall not be used to induce settling.
- (2) Seed shall be applied and evenly distributed on the entire bio-cell surface with adequate even coverage at a rate of 5 pounds per 1000 square feet. Fertilizer shall be included and applied as necessary per seed company recommendations. Plug plants shall be planted around the upper perimeter as per the plan. After initial germination, contractor shall fill missing areas and replace dead plants, if any, at no additional cost. For one full growing season after planting, the contractor shall return monthly to remove nuisance plants as described in the City of La Crosse Standard Procedures.
- (3) Planting – The entire soil planting bed shall be mulched prior to planting vegetation to help prevent compaction of the planting soil during the planting process. Mulch shall be pushed aside for the placement of each plant.

240.3.3 Erosion Protection

- (1) Immediately following seeding and prior to planting plugs, the Contractor shall install an erosion control blanket. Following installation of mat, Contractor shall cut slits into mat to facilitate the planting of plugs. Points of concentrated flow shall be protected with geofabric and rip-rap.

240.4 Measurement

- (1) Common Excavation. After excavation and prior to placement of engineered soil, contractor together with the project engineer shall take cross-sectional measurements of the excavated area. The department shall pay for this item per cubic yard (CY).
- (2) Engineered Soil. Contractor together with Project Engineer shall take cross-sectional measurements of the excavated area and calculate the volume of the naturally compacted engineered soil to be installed in place. Department will pay for this item per cubic yard (CY) of Bio-cell engineered soil, furnished and installed in place.
- (3) Install Bio-Cell. Install Bio-Cell item shall include seed, fertilizer, erosion protection, and maintenance of the bio-cell. BioCell shall be accepted after substantial (more than 85%) growth is achieved, erosion protection is removed, maintenance period is complete, and vegetation has reached a mature stage. The department shall pay for this item per square yard (SY) measured after installation.

240.5 Payment

The department will pay for the measured quantity at the contract unit price under the following bid items:

ITEM NUMBER	DESCRIPTION	UNIT
240.01	Common Excavation for Bio-Cell	CY
240.02	Furnish and Install Engineered Soil	CY
240.03	Install Bio-Cell	SY

240.6 Testing, Acceptance, & Maintenance

- (1) BioCell shall be accepted after substantial (more than 85%) growth is achieved, erosion protection is removed, maintenance period is complete, and vegetation has reached a mature stage.

240.6.1 Maintenance

- (1) Watering and maintenance activities shall continue by Contractor, for sufficient growth and to replace or supplement needed seed, for three months or until October 15th of the year the BioCell was built. If the BioCell construction is completed after October 1st, maintenance activities should be extended into the next year beginning April 1st such that the BioCell is maintained for a total of 3 months of warm weather conditions allowing for vegetation growth.



Engineering Department

400 La Crosse St., La Crosse, WI 54601 • (608) 789-7505 • Fax: (608) 789-8184
<http://www.cityoflacrosse.org>

- (2) After initial germination, contractor shall return and fill missing areas and replace dead plug plants, if any, at no additional cost to the owner.
- (3) For one full growing season after planting seed mixture, the contractor shall return monthly to eradicate the below species from the seeded areas: The year begins on the date of final planting. Eradicate by hand pulling or by applying a vegetation control herbicide.

SPECIES COMMON NAME	SPECIES BOTANICAL NAME
Musk thistle	Carduus nutans
Spotted knapweed	Centaurea maculosa
Canada thistle	Cirsium arvense
Bull thistle	Cirsium vulgare
Field bindweed	Convolvulus arvensis
Leafy spurge	Euphorbia esula
Sweetclover	Melilotus species
Wild parsnip	Pastinaca sativa

- (4) Immediately after construction completion Contractor shall install sandbags at the entrance to the BioCell. They will keep stormwater away from entering into the device and eroding unprotected soil. It shall be the Contractors responsibility to maintain those sandbags for the duration of maintenance period and remove them only after 80% or more vegetation is established and soil is protected from erosion.



Engineering Department

400 La Crosse St., La Crosse, WI 54601 • (608) 789-7505 • Fax: (608) 789-8184
<http://www.cityoflacrosse.org>

4. WATER CONSTRUCTION

- 400 GENERAL WATER CONSTRUCTION
- 401 EXCAVATION, BEDDING, & BACKFILL
- 402 INSULATION BOARD WATER
- 405 WATER MAIN
- 410 VALVE & VALVE BOX
- 415 HYDRANT CONSTRUCTION
- 420 WATER SERVICE LATERAL



4. WATER CONSTRUCTION

400-GENERAL WATER CONSTRUCTION

400.1 General Description

- (1) Perform work in accordance with the provisions of WisDOT Standard Specifications for Highway and Structure Construction except as hereinafter modified.
- (2) The following requirements must be fulfilled before grades are set and approval is given to commence work:
 - A. Contract forms to be completely executed.
 - B. Notice to utilities given.
 - C. Clearance from Engineer regarding disposal of surplus material, detouring of traffic, closing of streets and alleys, city facilities and services, shall be obtained by the Contractor.

400.2 Materials

- (1) Equipment and tools necessary for performing all parts of the water main, hydrants, or service work shall be satisfactory as to design, capacity, and mechanical condition for the purposes intended, and any equipment which is not maintained in full working order, or which as used by the Contractor is inadequate to obtain the results prescribed, shall be repaired, improved, replaced, or supplemented to obtain the progress and workmanship contemplated by the contract.
- (2) The Concrete used in the construction and installation of water main, or appurtenances shall conform to the requirements for General Concrete as specified in the City of La Crosse Standard Procedures.
- (3) All Concrete, Bituminous, and gravel pavements, sidewalks, curbs and gutters, fences, boulevard restoration, or other structures which may have been damaged or displaced by the Contractor in constructing the water main, hydrants, or services shall be rebuilt or re-laid properly to the original line and grade in accordance with City of La Crosse Standard Procedures.
- (4) Portable job office shall be furnished by the Contractor during cold weather operations when requested by the Engineer. Suitable desk and bulletin board shall be provided as well as adequate heating and lighting facilities. The office shall be available to City Inspectors and other personnel designated at all times and shall be placed conveniently to the location of the work.

400.2.1 Water Main and Hydrant Fittings

- (1) All Fittings (tees, crosses, reducers, elbows, etc.) for the water main shall conform to AWWA C110 or C153 latest designation, specifications for the size indicated on plans. All fittings shall have a pressure rating of 350 psi, shall be cement lined in accordance with AWWA C104, and shall have mechanically restrained joints.
- (2) All fittings shall have an exterior strap or cable for electrical conductivity.
- (3) In lieu of strapping of the joints and fittings, conductivity may be achieved by use of American Conductivity Gaskets. The conductivity gasket with copper inserts may be installed throughout the system to provide conductivity.

400.2.2 Joints

- (1) All joints shall be mechanically restrained using EBAA Iron, Inc. or MEGALUG™ retainer glands according to manufacturer's specifications.
- (2) For slip type bell and spigot pipe, a single rubber gasket shall be used to effect the joint seal. The gasket, gasket seat, and the plain end must be wiped clean to effect a good join. Only rubber gasket lubricant furnished by the manufacturer shall be used.

400.2.3 Gaskets

- (1) All gaskets for ductile iron pressure pipe and fittings shall conform to AWWA C111, latest designation specifications. The gaskets and joints shall have the same pressure rating as the pipe or fitting of which they are a part.



400.2.4 Polyethylene Encasement

- (1) Polyethylene encasement shall be applied to all pipes, fittings, valves and other appurtenances. The encasement shall be in tube or sheet form sized for each pipe diameter, 8mil. thickness, and conform to AWWA C105, latest designation, specifications.
- (2) The polyethylene encasement shall prevent contact between the pipe and surrounding backfill and bedding material, but is not intended to be airtight or watertight. All rips, punctures or other damage shall be repaired with adhesive tape or with a short length of new encasement wrapped around damaged area secured in the same manner as overlaps. Overlaps shall be a minimum of one foot at the end of each section and shall be secured by use of adhesive tape, plastic string or other material capable of holding the encasement in place until backfilling operations are completed.

400.3 Construction Methods

- (1) Removal of all Concrete, asphalt, trees, brush, sidewalk, or other surface materials shall be done in compliance with the City of La Crosse Standard Procedures.
- (2) The Contractor shall not, unless the proper parties have given written consent, enter or occupy with men, tools or materials any land adjoining the work.
- (3) The Contractor shall safeguard engineering stakes; and resetting, made necessary through carelessness of workmen, shall be done by the City at the Contractor's expense.
- (4) The water main, hydrants, and services are to be kept entirely free from rubbish of every kind as its construction progresses. All refuse and surplus matter must be scraped off. The same provisions are to be complied with in regard to water manholes.
- (5) No masonry, mortar or other cement work shall be done during freezing weather unless the Contractor shall provide the necessary means for, and shall heat the bricks, gravel, sand and water, and shall comply with all requirements to thoroughly protect the masonry from frost during and after laying; all at the cost and expense of the Contractor and with the approval of the Engineer.

400.3.1 Dewatering

- (1) The Contractor shall keep all excavations free of water during and until completion of the work, as directed by the Project Engineer. The Contractor shall be responsible for the continuous control of water at all times during the course of construction, and shall provide adequate backup systems to accomplish control of water entering excavations, trenches, and other parts of the work and shall keep said excavations dry until the structures or utilities to be built therein are completed.
- (2) No masonry or concrete shall be installed in water nor shall water be allowed to rise over masonry and/or concrete at least twenty-four (24) hours after the concrete has been placed. Water shall be controlled during periods when concrete is being placed, when pipe is being laid, and as such other times as is necessary for efficient and safe execution of the work.
- (3) The Contractor shall protect all local water supplies from harm as a result of dewatering operations, and provide remedial measures for any situations where such harm occurs.
- (4) All water removed from the construction site shall be discharged through pipes or hoses. The conveying of water in open ditches or trenches will not be allowed. Water shall be discharged in a manner that will not cause soil erosion at the discharge point. Discharge shall not cause siltation or flooding in any stream, storm sewer, or on adjacent properties.
- (5) All costs for making all extra excavations necessary to prevent the water from interfering with the proper construction of the work, bailing, pumping, and dewatering shall be borne by the Contractor, and included in the prices bid for other items of work. All required pumping, drainage, and disposal of groundwater shall be done without damage to adjacent property or structures, or to the operations of other Contractors and without



interference with the access rights of public or private parties. The Contractor shall modify the water control system at their own expense if, after installation and while in operation, it causes or threatens to cause damage to adjacent property or to existing buildings, structures, or utilities.

400.3.2 Thrust Blocking

- (1) Concrete thrust blocks shall not be accepted. Mechanically restrained joints shall be required.

400.3.3 Other Utilities

- (1) The location of pipes and other underground objects are approximately correct as shown on the plans, but should they be found to be otherwise, the Contractor shall have no claim on that account, it being understood that the Engineer does not warrant the plot of underground objects to be correct.
- (2) The Contractor shall notify all utilities, both public and private, including gas, electric, garbage collection, telephone, sewer and water, of his schedule of operations. The notice shall be given at least 48 hours prior to actual date of the commencing of construction. The Contractor shall also check as to any utility facilities which may be encountered during construction and take due notice of it.
- (3) The same notice and determination of facilities which may be encountered as well as to proposed blocking of streets or alleys shall be given to the Fire and Police Departments so as to enable them to maintain and plan their operations.
- (4) The Contractor shall give special attention to safeguarding and protecting all utilities, public and private, and shall be held liable for any damage thereto encountered during construction of the entire project. Relaying or relocating of gas mains or fiber optic/communication lines to expedite construction of the water main, hydrants, and services will be permitted providing it is done at no additional cost to the City following approval of such change by Xcel Energy or CenturyLink and their agreement with the Contractor as to payment of costs incurred and specifications for the work. A notarized copy of such agreement, signed by the Contractor and Xcel Energy or CenturyLink, shall be filed with the Board of Public Works before work is started.
- (5) Access to all hydrants and valves must be provided at all times because of emergency requirements of Water and Fire Departments.

400.3.4 Trees

- (1) The Contractor shall be responsible for trees damaged during the course of construction, as well as required trimming as directed by Engineering Department.

400.3.5 Property of the City

- (1) If the City furnishes pipe or material, all cuttings and pieces of pipe or other material shall be the property of the City, and at the completion of work, all such cuttings and pieces or material unused and all salvage from existing City mains or structures shall be delivered to Myrick Park Station supply yard.
- (2) All existing water main pipe and fittings salvaged during completion of the work shall be the property of the Water Utility, unless otherwise stated in the Special Specifications.
- (3) All water main fittings shown on the plans but not installed for some reason shall be the property of the Contractor unless the Water Department wants the fitting. Cost of the fittings, as determined from "Shipping Invoice" plus 10% shall be deducted from payment to the Contractor unless the Water Department takes the fitting.
- (4) Any water main fittings and pipe required for the final installations but not shown on the plans shall be installed, if determined necessary by the Engineer. These fittings shall be paid for on a cost of fitting, as determined from shipping invoice, plus 10% (no labor cost to be included).

400.4 Testing, Acceptance, & Maintenance

- (1) At the request of the Engineer or Inspector, the Contractor shall provide gradation testing for bedding material or backfill material. The gradation test shall be incidental to the pipe or structure removal, install or replacement.

400.4.1 Disinfection



Engineering Department

400 La Crosse St., La Crosse, WI 54601 • (608) 789-7505 • Fax: (608) 789-8184
http://www.cityoflacrosse.org

- (1) Before placing in service, all new mains, temporary mains, temporary services, or extensions to existing mains shall be chlorinated so that a chlorine residual of not less than 10 PPM remains in the pipe at the end of 24 hours and meet AWWA C600, Section 4 requirements. Any of the following compounds and methods of procedure shall be followed subject to approval of the Engineer.

Compound	Amount	Quantity of Water
Calcium Hypochlorite (HTH) (6-70% cl)	1 pound	7.5 gallons
Chlorinated Lime (bleaching powder) (30-35% cl)	2 pounds	7.5 gallons
Sodium Hypochlorite (liquid laundry bleach) (5.25% cl)	1 gallon	4.25 gallons

The above preparation will produce a 1% chlorine solution (10,000 PPM), and shall be applied to the new mains in the following amounts.

Requirements for 100 FT. Lengths of Pipe

Pipe Diameter	100% Chlorine	1% Chlorine Solution
6	0.06 lbs.	¾ gallon
8	0.10 lbs.	1 1/3 gallons
10	0.17 lbs.	2 gallons
12	0.24 lbs.	3 gallons

- (2) The point of application of the chlorinating agent shall be at the beginning of the extension through a corporation stop furnished by this Contractor, and installed in the top of the pipe, at a valve manhole or place designated by the Engineer.
- (3) During the disinfection operation, valves shall be manipulated by the Water Utility personnel so that the strong chlorine solution in the line being treated will not flow back into the line supplying water.
- (4) Following chlorination and successful completion of hydrostatic pressure test, all water shall be thoroughly flushed from the new mains, in accordance to the Wisconsin DNR WPDES General Permit. And before placing in service a sample or samples shall be collected and shall be tested by "Standard Methods" for bacteriological quality and shall show the absence of coliform organisms.
- (5) The Contractor shall furnish sterile bottles for collection of samples by the Engineer. This Contractor shall pay all costs for bottles, transportation and testing with costs included in the unit prices bid. An Affidavit of Compliance from a State Certified Laboratory shall be furnished to the Engineer, certifying the water sampled to be free of coliform bacteria contamination.
- (6) Should the initial treatment fail to produce a bacteriologically safe sample, the disinfecting and sampling process shall be repeated at the Contractor's expense. The City will furnish the water for the first flushing, up to eight (8) hours. If additional flushing is required, the Contractor shall pay \$35.00 per hour per hydrant used for flushing.

400.4.2 Hydrostatic Testing

- (1) Those portions of mains connected to existing system which cannot be separated from the mains in place without subjecting the existing piping to test pressures, and any other portions of systems so designated by the Engineer, shall stand with the joints exposed and under ordinary main pressure for a minimum period of six hours after which time they shall be inspected by the Water Utility upon notification by the Contractor. If any leaks or damages become apparent, repairs shall be made by the Contractor and testing shall begin again.
- (2) The hydrostatic test and leakage test of the system beyond the point of initial valving shall consist of raising the water pressure in the main to 150 psi for two hours, as per Section 5 AWWA C600, latest designation, specifications. Any leaks or damages that may develop during testing due to improper materials or workmanship shall be repaired



and testing begun again. The Contractor shall furnish a hand pump and gauge for this test. (Air pressure will not be used for this test). The Engineer may require that the whole or any part of the system be tested as a unit.

- (3) No request for a test shall be made of the Water Utility after 1:00 PM for a test on the same date.
- (4) The contractor may split up the pressure testing of the water main he installs into sections or test it all at once as he sees fit. Any temporary valves, plugs, piping, etc. necessary for the tests are the Contractors responsibility to furnish at no extra cost.
- (5) The Contractor shall install all temporary air release corporations as necessary to release all the air in the main for obtaining an adequate pressure test. Cost of these air releases is to be included in the bid for pipe installation.

400.4.3 Electrical Conductivity & Testing

- (1) Cast iron pipe shall be mechanical joint or push-on joint furnished with integrally installed conductors. Each joint, including fittings, shall be electrically banded with an external copper jumper capable of carrying 500 amps of current for an extended period of time to provide integral electric thawing capabilities. These copper jumpers can be either shop or field applied in accordance with these specifications. For field applied copper jumpers, either "thermOweld" as manufactured by Burndy Corp. Norwalk, Conn., or "Cadweld" by Erico Products Co., Cleveland, Ohio, will be permitted.
- (2) Contractors or suppliers shall submit the method they propose to use for approval prior to construction.
- (3) Copper Jumpers shall be a minimum 1/16" x 1/2" wide flat strip or equal cross section round copper wire in annealed condition conforming to ATM Specifications. B152-58 Type DHP. All copper jumpers shall be welded to the pipefittings by the metal arc welding process if shop applied or by the exothermic welding process if field applied.
- (4) On mechanical joints, fittings shall be attached to the bolts. The copper jumpers can be applied as a single strip welded at each end across the joint, or by multiple strips with bolted connections in the middle, Silicon bronze bolts and nuts shall be used on all bolted connections.
- (5) All welded connections shall be made on a clean metal surface, which has been ground to remove coating and oxide. The area at the connection, including weld, shall be refinished with its original coating, or other approved protective coating.
- (6) The assembled copper jumper across the joints shall be so installed that expansion, contraction, or relative pipe movement will not damage or sever the connection.



401-EXCAVATION, BEDDING, & BACKFILL

401.1 General Description

- (1) Work in this section shall consist of excavations, preparations, and backfilling required for placing of water main pipes, fittings, hydrants, or structures.

401.2 Materials

- (1) Bedding and Backfill material shall conform to WisDOT Standard Specifications for Highway and Structure Construction. The use of reclaimed asphalt, reprocessed material, or blended material shall not be allowed.

401.2.1 Bedding Material

- (1) Bedding material shall conform to WisDOT $\frac{3}{4}$ " dense graded base gradation. Native materials meeting the bedding requirements may be used for the installation of water main in the judgment of the Engineer, is free from debris and organic material, and meets the gradation requirements.

401.2.2 Backfill Material

- (1) Backfill material shall conform to WisDOT $\frac{1}{4}$ " dense graded base gradation. Excavated material may be used as backfill if it is suitable material in the judgment of the Engineer, is free from debris and organic material, and meets the gradation requirements.

401.3 Construction Methods

- (1) All excavations, bedding material, or backfilling material shall be incidental to the water main, hydrants or structure.

401.3.1 Excavation

- (1) The excavations must either be sloped or supported as required to comply with OSHA Excavation standards as defined in 29 C.F.R Part 1926, Subpart P.
- (2) The trench in which the water main and appurtenances are to be constructed shall be excavated in all cases in such manner and to such depths and widths as will give suitable room for the building of the structures they are to contain, and for bracing and supporting, pumping and draining, and for removing from the trench peat, silt or other materials which may not be deemed proper for foundations.
- (3) Not more than one city block of trench shall be opened in advance of the completed water main, except by permission of the Engineer, nor shall the limits of such open trench extend simultaneously across two streets intersecting the street in which the work is being done; nor in the case of a sheathed trench shall the opening in the street extend farther in length than the amount of sheathing physically present on the site.
- (4) The bottom of the trench is, in general, to be excavated to the exact form and size of the lower portion of the water main which is to be laid in it. In case of pipe water main, the bottom of the trench shall be trimmed, to the form of the outside of the pipes, with additional excavation at the joints, so that the bearings shall be continuous and the pressure shall be equally distributed.
- (5) Where salvageable material such as crushed rock or stone, of a depth of 6-inch or more, is encountered in excavation for utility installation, such material shall be carefully removed and segregated for future use by the City or as directed on the project by the Engineer. In such cases, the Engineer shall order removal and segregation of materials considered salvageable, where it shall be stored, and whether or not it is to be used by the Contractor in final backfilling operations on the project involved. Contractor shall be compensated for hauling of salvaged material on the same basis as for excess dirt or debris.
- (6) All materials shall be so placed as not to endanger the work, and so free access may be had at any time to all parts of the trench and all hydrants and gate valves in the vicinity. They shall be kept neatly piled so as to inconvenience



as little as possible to the public travel or the adjoining tenants. Reasonable provisions shall be made for travel on the streets, roads, railroads and private ways.

- (7) Care shall be taken not to move, without the consent of the Engineer, any sewers, drains, water or gas pipes, or other structures, and in crossing these, and in running parallel or near them, they shall be sustained securely in place until the work is completed. Whenever it is necessary to interfere with said structures, the Contractor shall maintain their respective services, and if necessary for that purpose, shall leave them in as good condition as they were previous to the commencement of the work. If so directed by the Engineer, permanent changes of locations not indicated on the plans nor in specifications shall be made by the Contractor to meet the requirements of the sewer and appurtenances, and new work shall be added, when necessary, to leave all in good working order. The cost of such permanent changes not indicated on the plans nor in the specification is to be paid for as extra work, on the valuation of the Board of Public Works, and depending on the decision of the engineer as to whether the work done is not included in the work required by the Contractor under his contract. Any damage done or caused to said pipe or other existing structures by act or neglect on the part of the Contractor is to be paid by him.
- (8) The Contractor shall be responsible for disposing of all excess dirt and debris resulting from construction. The City will not furnish a disposal site unless otherwise stated on the plans or in the Special Specifications.
- (9) No stone monuments, bench marks, etc., of any description, located in line of the work, shall be removed or taken up unless it be in the presence of the Engineer or City Inspector.

401.3.2 Rock Excavation

- (1) Rock excavation shall be defined as removal of igneous or sediment deposits laying in solid beds or layers in their original position which cannot be removed with the types of excavating machinery usually employed for trench excavation of the character involved in this contract. Rock excavation shall also include removal of boulders larger than $\frac{1}{2}$ cubic yard in volume and of ledge rock, concrete or masonry structures that require drilling or blasting. Rock excavation shall not include boulders less than $\frac{1}{2}$ cubic yard in volume, loose rock, or soft, friable, decomposed rock able to be removed with normal excavation equipment.
- (2) Where rock is encountered, the ditch width shall be narrowed to the minimum width required for laying of the pipe subject to the approval of the engineer. The pay width for rock excavation shall be the average width of the excavated trench but shall not exceed the outside pipe diameter plus 2 feet. The trench shall be excavated 4-inches below the outside of the pipe barrel and the exterior of all joints.
- (3) Volumetric measurement of rock in the trench shall be the basis for determining the quantity of rock excavation and shall be computed from average trench width, to of rock profile, and profile 4-inches below exterior of pipe joints. Boulders in excess of $\frac{1}{2}$ cubic yard volume will be based on actual volume removed from the trench. The pay quantity for rock excavation for manholes and structures will be one foot beyond the outside neat lines of the manhole or structure.
- (4) If blasting is to be used to remove rock, the Contractor must first obtain a blasting permit from the Mayor as required under Municipal Code 18-2.
- (5) The Wisconsin Administrative Code on Explosives and all local ordinances regulating blasting shall be adhered to. The Contractor will be held responsible for any damage to work performed by others or to adjacent property due to his blasting operation.

401.3.3 Bedding

- (1) The bedding, or foundations, for water main pipes shall be constructed to prevent settlement of the pipes and to avert excessive pressure on the pipes in order to avoid rupture, leakage, or deformation of the pipes.
- (2) The Contractor may use existing undisturbed ground for pipe foundation if approved by the Engineer or City Inspector.
- (3) After the excavation is complete, a layer of bedding material shall be spread over the bottom of the trench at the minimum depth of 4-inches. The pipe can be installed and jointed with a uniform support from the bedded



material. The bedding material shall be brought up to a level even with the spring line of the pipe and carefully compacted by hand when the trench is wet.

401.3.4 Backfilling

- (1) All excavations shall be backfilled as ordered by the Engineer or City Inspector, unless other protection of the pipeline is directed. The backfill should be solidly tamped about the pipes up to a level at least one foot above the top. This material should be deposited in uniform layers of 6 inches or less. Unless otherwise permitted, each layer should be solidly tamped or rammed with proper tools so as not to disturb the pipeline. Backfill material shall be clean and approved by the Engineer, free from rocks or broken concrete exceeding 2-inches in size.
- (2) The remainder of the excavation shall be backfilled by mechanical compaction methods. Backfill shall be placed in layers not generally exceeding 12-inches in depth, and each layer thoroughly compacted before the following layer is placed.
- (3) The mechanical compaction equipment shall be capable of compacting the backfill to the specified density. If not otherwise specified, the required density shall be 95% of maximum (Proctor) density. Prior to backfilling, the Engineer or City Inspector shall approve the type of mechanical compaction equipment and the compaction method.
- (4) The Engineer reserves the right to reject any compaction method that may damage the sewer pipe or other utilities or structures. This does not relieve the Contractor of any liability for such damage.
- (5) As the work progresses, all rubbish or refuse, and all unused materials and tools shall be removed at once from the ground. Whenever this clearing of rubbish from the streets, or the repairing of the street surfaces, fences or other damage is neglected, notice may be given to that effect to the Contractor, and if said rubbish is not removed or said repairs not done within two days thereafter, or if the Contractor does not at once take the necessary precautions to insure safety of public travel, the Board may employ other parties to do such work and the expense thus, incurred will be deducted from any moneys due or that may become due to the Contractor.
- (6) When, for any reason, the work is left unfinished, all excavations shall be filled if so required and the roadways and sidewalks be left unobstructed, and with the surfaces in a safe and satisfactory condition.
- (7) No Excavated material, except the road surfacing and a limited amount of sand and gravel to be used for masonry, shall be left on the streets; but such material shall be backfilled into the trench or carted away.

401.4 Testing, Acceptance, & Maintenance

- (1) **At the request of the Engineer or Inspector**, the Contractor shall provide gradation testing before bedding material or backfill material. The gradation test shall be incidental to the pipe or structure removal, install, or replacement.



402-INSULATION BOARD WATER

402.1 General Description

- (1) This section describes the furnishing and installation of insulation board within the project limits.

402.2 Materials

- (1) Polystyrene insulation shall be suitable for underground installation. It shall meet Fed. Spec. HH I 524C. It shall have a compressive strength of at least 35 psi, minimum Rvalue of 5, and maximum water absorption of 0.17% by volume. Sheets shall be no less than 4-inch thick.

402.3 Construction Methods

- (1) Insulation shall be installed between the watermain and storm/sanitary sewer in areas where there will not be at least 1.5' of separation between watermain and storm/sanitary sewer.
- (2) Insulation shall be installed when depth of watermain is less than 7'.
- (3) Insulation shall be installed according to typical details or as directed by City Staff.

402.4 Measurement

- (1) The department will measure insulation board polystyrene (4") by the SF furnished and acceptably installed.

402.5 Payment

The department will pay for the measured quantity at the contract unit price under the following bid item:

ITEM NUMBER	DESCRIPTION	UNIT
402.01	Insulation Board Water	SF

Payment is full compensation for furnishing materials and installation according to plans

402.6 Testing, Acceptance, & Maintenance

N/A



405-WATER MAIN

405.1 General Description

- (1) This section describes removing, abandoning, replacing, or installing new water main. The materials furnished and installed shall conform to the requirements specified herein for the type of material named in the plan.

405.2 Materials

- (1) Furnish pipe consistent with the pipe diameter bid item indicated in the plan. Base materials and backfilling materials shall conform to the City of La Crosse Standard Procedures.
- (2) Unless otherwise directed by the Engineer, all pipe and accessories shall be unloaded at the point of delivery, and hauled to and distributed at the site of the work by the Contractor. The materials shall be at all times handled with care to avoid damage. The material shall not be dropped or bumped against the ground, other pipes and accessories already on the ground, or any other objects on the ground.
- (3) The Contractor shall furnish random lengths of pipe for each contract as may be required for the proper placement of fittings or structures.
- (4) Unless otherwise specified, references to various standard specifications and test methods shall be understood to mean the specification or test method which is current on the date of awarding of bid.

405.2.1 Remove/Abandon/Replace

- (1) The existing water main pipe may consist of ductile iron, cast iron, HDPE, or PVC.

405.2.2 Ductile Iron Pipe

- (1) Ductile iron pipe shall meet AWWA C150 for thickness design and C151 for material. Pipe thickness shall meet pressure Class 350 psi having the following nominal wall thickness for up to 10 feet of bury, CL 52 thickness. For depth less than 3 feet, see plans or Special Specifications. All ductile iron pipe shall be cement lined in accordance with AWWA C104 (latest designation).

Pipe Diameter	Wall Thickness (in)
6 inch	0.25
8 inch	0.25
10 inch	0.26
12 inch	0.28
14 inch	0.31
16 inch	0.34
18 inch	0.36
20 inch	0.38
24 inch	0.43

- (2) Full lengths of pipe shall be used when connecting to valves or fittings, unless mechanically restrained. In addition to mechanically restrained pipes, no pipe shall be less than 3 feet in length, unless approved by Engineer or City Inspector.
- (3) All fittings (tees, crosses, reducers, elbows, etc.) for the water main shall conform to AWWA C110 or C153 latest designation, specifications for the size indicated on plans. All fittings shall have a pressure rating of 350 psi, shall be cement lined in accordance with AWWA C104, and shall have mechanically restrained joints.
- (4) All fittings shall have an exterior strap or cable for electrical conductivity.
- (5) In lieu of strapping of the joints and fittings, conductivity may be achieved by use of American Conductivity Gaskets. The conductivity gasket with copper inserts may be installed throughout the system to provide conductivity



- (6) All fittings shall be incidental to the pipe installed.

405.3 Construction Methods

- (1) The foundations, or bedding, in the trench shall be formed to prevent any subsequent settlement, which might result in excessive pressure and consequent rupture of the pipes. If the foundation is rock, an equalizing bed of concrete or sand shall be placed upon the rock and well compacted. The thickness of these beds shall be not less than four inches. If the foundation is good firm earth, the earth shall be pared or molded to give a full support to the lower third of each pipe, and, if necessary to secure a proper bearing for the pipe, a layer of concrete, fine gravel, or other suitable material shall be placed. The same means of securing a firm foundation shall be adopted in case the excavation has been made deeper than necessary.
- (2) All pipe twelve inches or under in diameter shall have seven (7) foot covering and pipe over twelve (12) inches in diameter shall be covered six (6) feet unless otherwise specified. This covering shall be measured from the established grade of the street to the top of the pipe. Pipe laid where grades have not been established shall be laid to the grade determined by the Engineer.
- (3) Dewatering shall be incidental to these items.

405.3.1 Removal

- (1) Removal limits are as shown on plans or by field markings done by engineer. Any removals or damage caused beyond this point without the engineer's permission will be the responsibility of the contractor to replace at their expense. The Contractor shall follow City of La Crosse Standard Procedures for excavation, trenching or shoring and backfilling operations.
- (2) Removals shall include the following but not limited to:
 - A. Equipment to facilitate removal and transport of pipe and soil.
 - B. Removal of pipe and offsite disposal.
 - C. Capping remaining pipe or structure if needed.
 - D. Additional Backfill material if needed.

405.3.2 Abandon

- (1) Abandon limits are shown on plans and/or by field markings done by engineer. Any damage caused beyond this point without the engineer's permission will be the responsibility of the contractor to replace at their expense.
- (2) Pipes identified on the plans for abandonment shall be plugged or filled with flowable fill as specified on the plans. The pipe shall be bulk headed and completely filled with a slurry like mixture.

405.3.3 New Water Main

- (1) The labor consists of laying water mains and appurtenances together with all specials, valves, hydrants, connections, street crossings, etc., for each size of pipe. The cutting in of new valves, and the connecting together of the new system with the present system as shown on plans, so that in the end it shall form and be a continuous part of the water system of the City of La Crosse.
- (2) The Contractor is responsible for maintaining line and grade for all pipes laid. The method used shall provide accurate line and grade for the existing construction conditions. The Contractor will be required to re-lay any pipe not installed on proper line or grade.
- (3) Pipe and specials shall be carefully handled at all times. They shall be placed in proper alignment in the trenches and evenly bedded before the joint is made. Each pipe shall be carefully inspected, cleaned, and disinfected before being laid. Those pipes not meeting the specifications shall be rejected. No pipe shall be laid except in the presence of the Engineer or Inspector, and the Engineer may order the removal and relaying of any pipe not properly laid.
- (4) A temporary watertight plug will be placed over the open end of the pipe to prevent dirt or other contamination from entering the main during trenching for placement of the next pipe. When breaks are taken and at the end of construction for the day a water tight plug will be installed in the end of pipe.



Engineering Department

400 La Crosse St., La Crosse, WI 54601 • (608) 789-7505 • Fax: (608) 789-8184
<http://www.cityoflacrosse.org>

- (5) Care must be taken when compacting the earth solidly under and around the pipe and specials before the filling of the trench begins. No loose rock backfill or rubbish will be allowed within two feet of the pipe or specials. Thrust blocks shall be provided as shown on the detail sheet and included in the cost bid for pipe.
- (6) No water main or water system shall be constructed, replaced or relocated in a flood-prone area unless designed and constructed to minimize or eliminate the infiltration of floodwaters into the system.
- (7) Minimum pipe length of a new main stub shall be 7 feet.

405.3.4 Replace

- (1) This item shall be used for replacing existing pipe with new DIP pipe when the existing pipe is located within the same trench. Removal of existing water main shall be incidental to this item
- (2) Connecting fittings shall be incidental to this item.
- (3) The Contractor shall follow construction methods for Pipe Laying when laying new pipe.

405.4 Measurement

- (1) The department will measure remove or abandon water main pipe by the lineal foot (LF) successfully removed and restored or abandoned. The measurement will be based on the plan quantities or field markings by the Engineer.
- (2) The department will measure each lineal foot (LF) of pipe furnished and successfully installed for all new and replaced water main pipe. The measurement will be made on the road from end of pipe to end of pipe.

405.5 Payment

The department will pay for the measured quantity at the contract unit price under the following bid items:

ITEM NUMBER	DESCRIPTION	UNIT
405.01-.03	Remove Water Main (Depth)	LF
406.01-.03	Abandon Water Main (Depth)	LF
407.01-.09	New DIP Water Main (Size)	LF
408.01-.09	Replace DIP Water Main (Size)	LF

405.6 Testing, Acceptance, & Maintenance

- (1) The cost of all testing by the Contractor shall be included in the unit price for the various size of water main pipe installed. For all tests, the Contractor shall install, backfill and clean all water mains and any related appurtenances prior to performing the tests.
- (2) All test shall follow the General Water Construction Section.



410-VALVE & VALVE BOX

410.1 General Description

- (1) This section describes removing, replacing, or installing new water valves. The materials furnished and installed shall conform to the requirements specified herein for the type of material named in the plan.

410.2 Materials

410.2.1 Gate Valve

- (1) All Valves shall meet or exceed AWWA Specification, latest edition. ANSI/AWWA C509 Resilient-Seated Gate Valves, 3-inch through 30-inch NPS, for Water and Sewage will be referred to as AWWA C509. AWWA C550 Protective Interior Coating for Valves and Hydrants will be referred to as AWWA C550.
- (2) The resilient-seated gate valve shall have the gate coated with a bonded elastomer, which also forms a seal on the cast iron valve body when the valve is in the closed position. When the valve is closed the seal is to allow no water to pass the valve at 200 psi differential pressure. The valve shall be operated by turning a 2-inch square operation nut attached to a corrosion resistant bronze stem, acting through a bronze stem nut, fixed into the disc.
- (3) All internal parts will be accessible without removing the valve body from the pressure line.
- (4) All cast iron internal parts shall be coated completely with a corrosion resistant coating.
- (5) The internal diameter of the water passageway shall be at least as large as the pipe inside diameter it is intended to be used with.
- (6) Each valve shall be tested by the manufacturer to have no leakage across the seat in either direction with 200 psi differential pressure and to have no bulkhead, stem or joint leakage when tested at 400 psi with the gate in the open position.
- (7) The only resilient-seated gate valves that will be accepted are:

American Darling CRS 80
Kennedy Ken-Seal
M&H (Dresser) 3067-01
Waterous Co. 2500 Series

Clow Corp. F6100
Mueller Co. A2370
US Pipe Metro Seal

- (8) The manufacturer or vender shall furnish the City an affidavit stating that the inspection and all the specified tests have been made and that the results thereof comply with the requirements of AWWA C509 and C550.
- (9) Valves shall be free from any defects whatsoever. They shall be uniform in size as to bore and thickness of metal and shall have full waterways and easy bends. If defective during the one-year guarantee period, all replacement costs, including the valve, removal of old, labor, and equipment, removal of debris, etc., shall be the responsibility of the Contractor.
- (10) All valves shall be thoroughly cleaned and with no lumps left in either the barrels or sockets. They shall be free from rust and shall be painted or coated with a material and in a manner conforming to the latest AWWA Specifications.

410.2.2 Valve Boxes

- (1) All valve boxes shall be screw type having a 5-1/4-inch shaft diameter.
- (2) Valve boxes shall be cast iron similar to the following: Cast Iron-Tyler 6860 Series or Standard #6 Base extension 59A Tyler, center section 60A Tyler, top section 26T, cover #145462 5-1/4" Drop Lid marked "WATER".
- (3) Valve boxes shall be set so that the bottom of the base section is the same elevation as the top of the stuffing box of the valve, shall be centered on the operating nut by use of a gate valve adapter, and shall not touch the body of the valve in any way with a minimum of two inches of clearance.



- (4) The contractor will provide proper length valve boxes and is responsible for checking the plans and determining the lengths needed prior to ordering boxes.

410.3 Construction Methods

- (1) The foundations, or bedding, in the trench shall be formed to prevent any subsequent settlement, which might result in excessive pressure and consequent rupture of the pipes. If the foundation is rock, an equalizing bed of concrete or sand shall be placed upon the rock and well compacted. The thickness of these beds shall be not less than four inches. If the foundation is good firm earth, the earth shall be pared or molded to give a full support to the lower third of each pipe, and, if necessary to secure a proper bearing for the pipe, a layer of concrete, fine gravel, or other suitable material shall be placed. The same means of securing a firm foundation shall be adopted in case the excavation has been made deeper than necessary.
- (2) Dewatering shall be incidental to these items.

410.3.1 Removal

- (1) Removal of valves are as shown on plans or by field markings done by engineer. Any removals or damage caused beyond this point without the engineer's permission will be the responsibility of the contractor to replace at their expense. The Contractor shall follow City of La Crosse Standard Procedures for excavation, trenching or shoring and backfilling operations.
- (2) Removals shall include the following but not limited to:
 - A. Equipment to facilitate removal and transport of valves and soil.
 - B. Removal of valves and offsite disposal.
 - C. Capping remaining pipe or structure if needed.
 - D. Additional Backfill material if needed.

410.3.2 New Gate Valve

- (1) The labor consists of setting a valve, the cutting in of new valves, and the connecting together of the new system with the present system as shown of plans, so that in the end it shall form and be a continuous part of the water system of the City of La Crosse.
- (2) The Contactor is responsible for matching line and grade of the pipe for the new valve. The method used shall provide accurate line and grade for the existing construction conditions. The Contractor will be required to re-set any valve not installed effectively vertical, so that a wrench can be used to open and close the valve.
- (3) Valves shall be carefully handled at all times. They shall be placed in proper alignment in the trenches and evenly bedded before the joint is made. Each valve shall be carefully inspected, cleaned, and disinfected before being laid. Those valves not meeting the specifications shall be rejected. No valve shall be laid except in the presence of the Engineer or Inspector, and the Engineer may order the removal and resetting of any valve not properly set.
- (4) Care must be taken when compacting the earth solidly under and around the valve and valve box before the filling of the trench begins. No loose rock backfill or rubbish will be allowed within two feet of the valve or valve box. Thrust blocks shall be provided as shown on the detail sheet and included in the cost bid for a valve.
- (5) No water main or water system shall be constructed, replaced or relocated in a flood-prone area unless designed and constructed to minimize or eliminate the infiltration of floodwaters into the system.

410.3.3 Replace

- (1) This item shall be used for replacing existing valves with new valves when the existing valve is located within the same trench. Removal of existing valve shall be incidental to this item
- (2) Connecting fittings shall be incidental to this item.
- (3) The Contractor shall follow construction methods for New Resilient-Seated Gate Valve when replacing valve.

410.3.4 Tapping Valve and Sleeve

- (1) This item shall be used for tapping a new valve onto an existing line when required.



Engineering Department

400 La Crosse St., La Crosse, WI 54601 • (608) 789-7505 • Fax: (608) 789-8184
<http://www.cityoflacrosse.org>

- (2) Connecting fitting shall be incidental to this item.
- (3) The Contractor shall follow construction methods for New Resilient-Seated Gate Valve when tapping a new valve.
- (4) Maximum live tap size shall be one size smaller than existing line. A larger tap shall require a control valve

410.4 Measurement

- (1) The department will measure all removed valves by the each (EA), regardless of size. This will also include the accompanying water manhole or valve box.
- (2) The department will measure all new, replaced, and tapping valves by the each (EA), based upon size. The unit price will also include the valve box, and extensions required.

410.5 Payment

The Department will pay for the measured quantity at the contract unit price under the following bid item:

ITEM NUMBER	DESCRIPTION	UNIT
410.01	Remove Valve (All)	EA
411.01-.09	New Gate Valve (Size)	EA
412.01-.09	Replace Valve (Size)	EA
413.01-.09	Tapping Valve (Size)	EA

410.6 Testing, Acceptance, & Maintenance

- (1) The cost of all testing by the Contractor shall be included in the unit price for the various size of water main pipe installed. For all tests, the Contractor shall install, backfill and clean all water mains and any related appurtenances prior to performing the tests.
- (2) All test shall follow the General Water Construction Section.



415-HYDRANT CONSTRUCTION

415.1 General Description

- (1) This section describes removing, replacing, or installing new hydrants. The materials furnished and installed shall conform to the requirements specified herein for the type of material named in the plan.

415.2 Materials

- (1) All hydrants shall conform to the AWWA Specifications latest edition ANSI/AWWA C502 Dry-Barrel Fire Hydrants (will be referred to as AWWA C502).
- (2) AWWA C550 Protective Interior Coatings for Valves and Hydrants (will be referred to as AWWA C550).
- (3) All hydrants shall have 6-inch mechanical joint connections and not less than a 5-inch valve opening. The internal diameter of the standpipe shall not be less than 5-1/2-inch in any place. Each hydrant will have one 4-inch steamer nozzle with La Crosse Pattern Threads and two 2-1/2-inch brass hose nozzles with National Standard Thread. Hydrants shall be of sufficient length so that the top of the hydrant shall be three feet above ground or curb grade and not less than 26-inches from the grade to the center of the hose connection.
- (4) Hydrants furnished under this contract must be self-draining and the valve stem must be capable of being withdrawn through the barrel. Hydrants shall be Waterous Pacer Breakaway Model WB-67-250 with a 22-inch top extension and with weathershield and 6-inch mechanical joint connections. Hydrants shall have a bury of 7-foot 6-inches unless listed otherwise in special specifications.
- (5) The manufacturer shall furnish the City an affidavit stating that the hydrant and all materials used in its construction conform to the applicable requirements of AWWA C502 and La Crosse Specifications, and that all tests specified therein have been performed and that all test requirements have been met.
- (6) Hydrants installed between La Crosse Street and Jackson Street, from 7th Street to the river west shall be red, hydrants installed out of this area shall be green.

415.3 Construction Methods

415.3.1 Removal

- (1) Removal of hydrants are as shown on plans or by field markings done by engineer. Any removals or damage caused beyond this point without the engineer's permission will be the responsibility of the contractor to replace at their expense. The Contractor shall follow City of La Crosse Standard Procedures for excavation, trenching or shoring and backfilling operations.
- (2) Removals shall include the following but not limited to:
 - A. Equipment to facilitate removal and transport of hydrant and soil.
 - B. Removal of hydrant and offsite disposal.
 - C. Capping remaining pipe or structure if needed.
 - D. Additional Backfill material if needed.

415.3.2 New Hydrant and Valve Cluster

- (1) All hydrants shall be set vertically plumb and be properly braced to insure against movement during backfilling operations. A minimum of 5 cubic feet of clean gravel (3/4-inch to 1-inch size) shall be placed around the shoe and drain of all hydrants and covered with two layers of approved plastic (8-mil thick) to keep the voids open.
- (2) Each hydrant shall be connected to the main with a 6-inch branch controlled by an independent 6-inch valve. The branch between the hydrant and valve will be at least three feet long and the valve will be installed with a valve box. The valve will conform to AWWA C509 and La Crosse Specifications.
- (3) All joints on the branch from the main to the hydrant will be restrained using EBAA Iron, Inc., MEGALUG TM retainer glands.



Engineering Department

400 La Crosse St., La Crosse, WI 54601 • (608) 789-7505 • Fax: (608) 789-8184
<http://www.cityoflacrosse.org>

415.3.3 Replace

- (1) This item shall be used to replace existing hydrants with new hydrants and valve clusters when the existing hydrant is located within the same trench. Removal of existing hydrant shall be incidental to this item.
- (2) Connecting fittings shall be incidental to this item.
- (3) The Contractor shall follow construction methods for New Hydrant and Valve Cluster.
- (4) A valve shall be included into this item whether or not there was an existing valve.

415.4 Measurement

- (1) The department will measure removed hydrants by the each (EA) for each hydrant removed and water main capped.
- (2) The department will measure new hydrant and valve clusters, along with replacement hydrant clusters by the each (EA). The clusters will be categorized by either "long lead" or "short lead" based upon whether the hydrant lead crosses the road centerline from the water main to the boulevard location. The Contractor shall include the length of the hydrant lead into the cost of the item, this include the lead from the main to the valve and the valve to the hydrant.

415.5 Payment

The department will pay for the measured quantity at the contract unit price under the following bid item:

ITEM NUMBER	DESCRIPTION	UNIT
415.01	Remove Hydrant	EA
416.01-.02	New Hydrant and Valve Cluster Group (Length)	EA
417.01-.02	Replace Hydrant Cluster Group (Length)	EA

415.6 Testing, Acceptance, & Maintenance

- (1) The cost of all testing by the Contractor shall be included in the unit price for the hydrants installed. For all tests, the Contractor shall install, backfill and clean all water mains and any related appurtenances prior to performing the tests.
- (2) All test shall follow the General Water Construction Section.



420-WATER SERVICE LATERAL

420.1 General Description

- (1) This section describes removing, replacing, or installing water services. Water services include the corporation stop, copper pipe, and the curb stop shut off & box. The materials furnished and installed shall conform to the requirements specified herein for the type of material named in the plan, current version of the Safe Water Drinking Act (SWDA) and the City of La Crosse Code of Ordinances.

420.2 Materials

420.2.1 Corporation Stop

- (1) Corporation stops installed shall be in accordance to AWWA C800 5.1.1 and ANSI/ASME B1.1.
- (2) Corporation stops shall be the arch style with compression fittings.
- (3) Corporation stops shall be 1" minimum diameter.
- (4) The only corporation stops manufacturers that will be accepted are:

Ford C84	M&H (Dresser) 0065
Mueller Co. H-15000	Smith Blair 264 Series
Telsco 704	

420.2.2 Copper Water Service Line

- (1) The material used for the copper water services shall comply with the AWWA C800 code, requiring the copper alloy to meet ASTM B88, type K standards.

420.2.3 Curb Stop Shut-Off & Box

- (1) The only curb stop shut-offs & boxes that will be accepted are:

ITEM	MANUFACTURER	PART NUMBER
Curb Box	Mueller	H10314
	Mc Donald	5601
Rod (54" or 57")	Mueller	82868
	Mc Donald	5660
Lid (2-Hole Style)	Mueller	87081
	Mc Donald	5601-L

- (2) Curb stop shut-offs shall have compression fittings on the City side and the Contractor shall verify private side connections.

420.3 Construction Methods

- (1) Transmission main (12" or greater) shall not be tapped for service line unless approved by the water department.

420.3.1 Corporation Stop

- (1) Corporations stops shall be tapped on the side of the main closest to the adjacent property and in line with the existing water service being replaced.
- (2) For new buildings/lots corporations shall be tapped as close to the center of the lot or to match plans for new buildings.
- (3) Any corporation stops 2-inch or smaller shall be tapped at a 45-degree angle from the springline of the water main.

420.3.2 Copper Water Service Line

- (1) The copper water service line shall be placed with enough slack to prevent stretching or pulling from the main.



Engineering Department

400 La Crosse St., La Crosse, WI 54601 • (608) 789-7505 • Fax: (608) 789-8184
<http://www.cityoflacrosse.org>

(2) Connections to the corporation stop and curb stop shall be compression fittings.

420.3.3 Curb Stop Shut-Off & Box

- (1) The curb stop shut-off and box shall be installed within the right-of-way and as close to the existing location as possible.
- (2) Preferred location of the curb stop shut-off and box is in a grass boulevard where available.
- (3) Any curb stop shut-off and boxes located in brick streetscaping shall require a 1'x1' concrete collar.
- (4) Any curb box located in concrete will require a valve riser with lid. The riser with lid will be provided by City Staff.
- (5) The box shall be installed and checked for vertical plumbness.
- (6) The Contractor shall use concrete blocking to help support the curb stop shut-off coupling.
- (7) It is the Contractors responsibility to check and verify the material of the existing service lead for proper connection fittings.
- (8) PVC sleeves shall only be used when approved on a case-by-case basis by the Water Department.

420.4 Measurement

- (1) The department will measure corporations stops installed by the each (EA) based upon the size. This item will include the cost of all fittings, the means to perform taps and any equipment required.
- (2) The department will measure the copper water service based upon the length of pipe installed in feet (LF) that connects the corporation stop to the curb stop.
- (3) The department will measure curb stop shut-off and box installed by the each (EA) base upon the size. This item will include the cost of all fittings, the curb box, and any other materials to connect to the existing service lead.

420.5 Payment

The department will pay for the measured quantity at the contract unit price under the following bid item:

ITEM NUMBER	DESCRIPTION	UNIT
420.01-.02	Corporation Stop (Size)	EA
421.01-.02	Copper Water Service Line (Size)	LF
422.01-.02	Curb Stop Shut-Off and Box (Size)	EA

420.6 Testing, Acceptance, & Maintenance

- (1) All test shall follow the General Water Construction Section.



6. SANITARY SEWER CONSTRUCTION

- 600 GENERAL SANITARY SEWER CONSTRUCTION
- 601 EXCAVATION, BEDDING, & BACKFILL
- 602 INSULATION BOARD SEWER
- 605 SANITARY SEWER PIPE
- 620 SANITARY SEWER STRUCTURE CONSTRUCTION
- 625 REPAIR/MODIFY EXISTING STRUCTURE
- 630 SEWER LINER (CIPP)
- 635 REHABILITATE MANHOLE
- 640 BY-PASS PUMPING



6. SANITARY SEWER CONSTRUCTION

600-GENERAL SANITARY SEWER CONSTRUCTION

600.1 General Description

- (1) Perform work in accordance with the provisions of WisDOT Standard Specifications for Highway and Structure Construction except as hereinafter modified.
- (2) The following requirements must be fulfilled before grades are set and approval is given to commence work:
 - A. Contract forms to be completely executed.
 - B. Notice to utilities given.
 - C. Clearance from Engineer regarding disposal of surplus material, detouring of traffic, closing of streets and alleys, city facilities and services, shall be obtained by the Contractor.

600.2 Equipment & Materials

- (1) Equipment and tools necessary for performing all parts of the sanitary sewer work shall be satisfactory as to design, capacity, and mechanical condition for the purposes intended, and any equipment which is not maintained in full working order, or which as used by the Contractor is inadequate to obtain the results prescribed, shall be repaired, improved, replaced, or supplemented to obtain the progress and workmanship contemplated by the contract.
- (2) The Concrete used in the construction and installation of sewers, structures, catch basins, inlets and other structures and appurtenances shall conform to the requirements for General Concrete as specified in the City of La Crosse Standard Procedures.
- (3) All Concrete, Bituminous, and gravel pavements, sidewalks, curbs and gutters, fences, boulevard restoration, or other structures which may have been damaged or displaced by the Contractor in constructing the sewer shall be rebuilt or re-laid properly to the original line and grade in accordance with City of La Crosse Standard Procedures.
- (4) Portable job office shall be furnished by the Contractor during cold weather operations when requested by the Engineer. Suitable desk and bulletin board shall be provided as well as adequate heating and lighting facilities. The office shall be available to City Inspectors and other personnel designated at all times and shall be placed conveniently to the location of the work.

600.3 Construction Methods

- (1) Removal of all Concrete, asphalt, trees, brush, sidewalk, or other surface materials shall be done in compliance with the City of La Crosse Standard Procedures.
- (2) The Contractor shall not, unless the proper parties have given written consent, enter or occupy with men, tools or materials any land adjoining the work.
- (3) The Contractor shall safeguard engineering stakes; and resetting, made necessary through carelessness of workmen, shall be done by the City at the Contractor's expense.
- (4) The sewer is to be kept entirely free from rubbish of every kind as its construction progresses. All refuse and surplus matter must be scraped off. The same provisions are to be complied with in regard to catch basins and manholes.
- (5) No masonry, mortar or other cement work shall be done during freezing weather unless the Contractor shall provide the necessary means for, and shall heat the bricks, gravel, sand and water, and shall comply with all requirements to thoroughly protect the masonry from frost during and after laying; all at the cost and expense of the Contractor and with the approval of the Engineer.

600.3.1 Dewatering

- (1) The Contractor shall keep all excavations free of water during and until completion of the work, as directed by the Project Engineer. The Contractor shall be responsible for the continuous control of water at all times during the



Engineering Department

400 La Crosse St., La Crosse, WI 54601 • (608) 789-7505 • Fax: (608) 789-8184
<http://www.cityoflacrosse.org>

course of construction, and shall provide adequate backup systems to accomplish control of water entering excavations, trenches, and other parts of the work and shall keep said excavations dry until the structures or utilities to be built therein are completed.

- (2) No masonry or concrete shall be installed in water nor shall water be allowed to rise over masonry and/or concrete at least twenty-four (24) hours after the concrete has been placed. Water shall be controlled during periods when concrete is being placed, when pipe is being laid, and as such other times as is necessary for efficient and safe execution of the work.
- (3) The Contractor shall protect all local water supplies from harm as a result of dewatering operations, and provide remedial measures for any situations where such harm occurs.
- (4) All water removed from the construction site shall be discharged through pipes or hoses. The conveying of water in open ditches or trenches will not be allowed. Water shall be discharged in a manner that will not cause soil erosion at the discharge point. Discharge shall not cause siltation or flooding in any stream, storm sewer, or on adjacent properties.
- (5) All costs for making all extra excavations necessary to prevent the water from interfering with the proper construction of the work, bailing, pumping, and dewatering shall be borne by the Contractor, and included in the prices bid for other items of work. All required pumping, drainage, and disposal of groundwater shall be done without damage to adjacent property or structures, or to the operations of other Contractors and without interference with the access rights of public or private parties. The Contractor shall modify the water control system at their own expense if, after installation and while in operation, it causes or threatens to cause damage to adjacent property or to existing buildings, structures, or utilities.

600.3.2 Other Utilities

- (1) The location of pipes and other underground objects are approximately correct as shown on the plans, but should they be found to be otherwise, the Contractor shall have no claim on that account, it being understood that the Engineer does not warrant the plot of underground objects to be correct.
- (2) The Contractor shall notify all utilities, both public and private, including gas, electric, garbage collection, telephone, sewer and water, of his schedule of operations. The notice shall be given at least 48 hours prior to actual date of the commencing of construction. The Contractor shall also check as to any utility facilities which may be encountered during construction and take due notice of it.
- (3) The same notice and determination of facilities which may be encountered as well as to proposed blocking of streets or alleys shall be given to the Fire and Police Departments so as to enable them to maintain and plan their operations.
- (4) The Contractor shall give special attention to safeguarding and protecting all utilities, public and private, and shall be held liable for any damage thereto encountered during construction of the entire project. Relaying or relocating of gas mains to expedite construction of the sewer will be permitted providing it is done at no additional cost to the City following approval of such change by Xcel Energy and their agreement with the Contractor as to payment of costs incurred and specifications for the work. A notarized copy of such agreement, signed by the Contractor and Xcel Energy, shall be filed with the Board of Public Works before work is started.
- (5) Access to all hydrants and valves must be provided at all times because of emergency requirements of Water and Fire Departments.

600.3.3 Trees

- (1) The Contractor shall be responsible for trees damaged during the course of construction, as well as required trimming as directed by Engineering Department.

600.4 Testing, Acceptance, & Maintenance

N/A



601-EXCAVATION, BEDDING, & BACKFILL

601.1 General Description

- (1) Work in this section shall consist of excavations, preparation, and backfilling required for placing of sanitary sewer pipes, fittings, or structures.

601.2 Materials

- (1) Bedding and Backfill material shall conform to WisDOT Standard Specifications for Highway and Structure Construction. The use of reclaimed asphalt, reprocessed material, or blended material shall not be allowed.

601.2.1 Bedding Material

- (1) Bedding material shall conform to WisDOT $\frac{3}{4}$ " dense graded base gradation. Native materials meeting the bedding requirements may be used for the installation of sanitary sewer in the judgement of the Engineer, is free from debris and organic material, and meets the gradation requirements.

601.2.2 Backfill Material

- (1) Backfill material shall conform to WisDOT $1 \frac{1}{4}$ " dense graded base gradation. Excavated material may be used as backfill if it is suitable material in the judgement of the Engineer, is free from debris and organic material, and meets the gradation requirements.

601.3 Construction Methods

- (1) All excavations, bedding material, or backfilling material shall be incidental to the sanitary sewer pipe or structure.

601.3.1 Excavation

- (1) The excavations must either be sloped or supported as required to comply with OSHA Excavation standards as defined in 29 C.F.R. Part 1926, Subpart P.
- (2) The trench in which the sewer and appurtenances are to be constructed shall be excavated in all cases in such manner and to such depths and widths as will give suitable room for the building of the structures they are to contain, and for bracing and supporting, pumping and draining, and for removing from the trench peat, silt or other materials which may not be deemed proper for foundations.
- (3) Not more than one city block of trench shall be opened in advance of the completed sewer, except by permission of the engineer, nor shall the limits of such open trench extend simultaneously across two streets intersecting the street in which the work is being done; nor in the case of a sheathed trench shall the opening in the street extend farther in length than the amount of sheathing physically present on the site.
- (4) The bottom of the trench is, in general, to be excavated to the exact form and size of the lower portion of the sewer which is to be laid in it. In case of pipe sewer, the bottom of the trench shall be trimmed, to the form of the outside of the pipes, with additional excavation at the joints, so that the bearings shall be continuous and the pressure shall be equally distributed.
- (5) Where salvageable material such as crushed rock or stone, of a depth of 6" or more, is encountered in excavation for utility installation, such material shall be carefully removed and segregated for future use by the City or as directed on the project by the Engineer. In such cases, the Engineer shall order removal and segregation of materials considered salvageable, where it shall be stored, and whether or not it is to be used by the Contractor in final backfilling operations on the project involved. Contractor shall be compensated for hauling of salvaged material on the same basis as for excess dirt or debris.
- (6) All materials shall be so placed as not to endanger the work, and so free access may be had at any time to all parts of the trench and all hydrants and gate valves in the vicinity. They shall be kept neatly piled so as to inconvenience as little as possible the public travel or the adjoining tenants. Reasonable provision shall be made for travel on the streets, roads, railroads and private ways.



Engineering Department

400 La Crosse St., La Crosse, WI 54601 • (608) 789-7505 • Fax: (608) 789-8184
<http://www.cityoflacrosse.org>

- (7) Care shall be taken not to move, without the consent of the engineer, any sewers, drains, water or gas pipes, or other structures, and in crossing these, and in running parallel or near them, they shall be sustained securely in place until the work is completed. Whenever it is necessary to interfere with said structures, the Contractor shall maintain their respective services, and if necessary for that purpose, shall lay temporary water, gas or other pipes. The Contractor shall repair all damage done to any of said structures, and shall leave them in as good condition as they were previous to the commencement of the work. If so directed by the engineer, permanent changes of location not indicated on the plans nor in specifications shall be made by the Contractor to meet the requirements of the sewer and appurtenances, and new work shall be added, when necessary, to leave all in good working order. The cost of such permanent changes not indicated on the plans nor in the specification is to be paid for as extra work, on the valuation of the Board of Public Works, and depending on the decision of the engineer as to whether the work done is or is not included in the work required by the Contractor under his contract. Any damage done or caused to said pipes or other existing structures by act or neglect on the part of the Contractor is to be paid by him.
- (8) The Contractor shall be responsible for disposing of all excess dirt and debris resulting from construction. The City will not furnish a disposal site unless otherwise stated on the plans or in the Special Specifications.
- (9) No stone monuments, bench marks, etc., of any description, located in line of the work, shall be removed or taken up unless it be in the presence of the Engineer or City Inspector.

601.3.2 Rock Excavation

- (1) Rock excavation shall be defined as removal of igneous or sediment deposits laying in solid beds or layers in their original position which cannot be removed with the types of excavating machinery usually employed for trench excavation of the character involved in this contract. Rock excavation shall also include removal of boulders larger than $\frac{1}{2}$ cubic yard in volume and of ledge rock, concrete or masonry structures that require drilling or blasting. Rock excavation shall not include removal of boulders less than $\frac{1}{2}$ cubic yard in volume, loose rock, or soft, friable, decomposed rock able to be removed with normal excavation equipment.
- (2) Where rock is encountered, the ditch width shall be narrowed to the minimum width required for laying of the pipe subject to the approval of the engineer. The pay width for rock excavation shall be the average width of the excavated trench but shall not exceed the outside pipe diameter plus 2 feet. The trench shall be excavated 4 inches below the outside of the pipe barrel and the exterior of all joints.
- (3) Volumetric measurement of rock in the trench shall be the basis for determining the quantity of rock excavation and shall be computed from average trench width, top of rock profile, and profile 4 inches below exterior of pipe joints. Boulders in excess of $\frac{1}{2}$ cubic yard volume will be based on actual volume removed from the trench. The pay quantity for rock excavation for manholes and structures will be one foot beyond the outside neat lines of the manhole or structure.
- (4) If blasting is to be used to remove rock, the Contractor must first obtain a blasting permit from the Mayor as required under Municipal Code 18-2.
- (5) The Wisconsin Administrative Code on Explosives and all local ordinances regulating blasting shall be adhered to. The Contractor will be held responsible for any damage to work performed by others or to adjacent property due to his blasting operation.

601.3.3 Bedding

- (1) The bedding, or foundation, for sanitary sewer pipes shall be constructed to prevent settlement of the pipes and to avert excessive pressure on the pipes in order to avoid rupture, leakage, or deformation of the pipes.
- (2) The Contractor may use existing undisturbed ground for pipe foundation if approved by the Engineer or City Inspector.
- (3) After the excavation is complete, a layer of bedding material shall be spread over the bottom of the trench at a minimum depth of four (4) inches. The pipe can be installed and jointed with a uniform support from the bedded



material. The bedding material shall be brought up to a level even with the spring line of the pipe and carefully compacted by hand when the trench is wet.

601.3.4 Backfilling

- (1) All excavations shall be backfilled as ordered by the Engineer or City Inspector, unless other protection of the pipeline is directed. The backfill should be solidly tamped about the pipes up to a level at least one foot above the top. This material should be deposited in uniform layers of 6 inches or less. Unless otherwise permitted, each layer should be solidly tamped or rammed with proper tools so as not to disturb the pipeline. Backfill material shall be clean and approved by the engineer, free from rocks or broken concrete exceeding 2 inches in size.
- (2) The remainder of the excavation shall be backfilled by mechanical compaction methods. Backfill shall be placed in layers not generally exceeding 12 inches in depth, and each layer thoroughly compacted before the following layer is placed.
- (3) The mechanical compaction equipment shall be capable of compacting the backfill to the specified density. If not otherwise specified, the required density shall be 95% of maximum (Proctor) density. Prior to backfilling, the Engineer or City Inspector shall approve the type of mechanical compaction equipment and the compaction method.
- (4) The Engineer reserves the right to reject any compaction method that may damage the sewer pipe or other utilities or structures. This does not relieve the Contractor of any liability for such damage.
- (5) As the work progresses, all rubbish or refuse, and all unused materials and tools shall be removed at once from the ground. Whenever this clearing of rubbish from the streets, or the repairing of the street surfaces, fences or other damage is neglected, notice may be given to that effect to the Contractor, and if said rubbish is not removed or said repairs not done within two days thereafter, or if the Contractor does not at once take the necessary precautions to insure safety of public travel, the Board may employ other parties to do such work and the expense thus incurred will be deducted from any moneys due or that may become due the Contractor.
- (6) When, for any reason, the work is left unfinished, all excavations shall be filled if so required and the roadways and sidewalks be left unobstructed, and with the surfaces in a safe and satisfactory condition.
- (7) No excavated material, except the road surfacing and a limited amount of sand and gravel to be used for masonry, shall be left on the streets; but such materials shall be backfilled into the trench or carted away.

601.4 Testing, Acceptance, & Maintenance

- (1) ***At the request of the Engineer or City Inspector***, the Contractor shall provide gradation testing for bedding or backfill material. The gradation test shall be incidental to the pipe or structure removal, install, or replacement.



602-INSULATION BOARD SANITARY

602.1 General Description

- (1) This section describes the furnishing and installation of insulation board within the project limits.

602.2 Materials

- (1) Polystyrene insulation shall be suitable for underground installation. It shall meet Fed. Spec. HH I 524C. It shall have a compressive strength of at least 35 psi, minimum Rvalue of 5, and maximum water absorption of 0.17% by volume. Sheets shall be no less than 4-inch thick.

602.3 Construction Methods

- (1) Insulation shall be installed when depth of sanitary lateral is less than 7'.
- (2) Insulation shall be installed according to typical details or as directed by City Staff.

602.4 Measurement

- (2) The department will measure insulation board polystyrene (4") by the SF furnished and acceptably installed.

602.5 Payment

The department will pay for the measured quantity at the contract unit price under the following bid item:

ITEM NUMBER	DESCRIPTION	UNIT
602.01	Insulation Board Sanitary	SF

Payment is full compensation for furnishing materials and installation according to plans

602.6 Testing, Acceptance, & Maintenance

N/A



605-SANITARY SEWER PIPE

605.1 General Description

- (1) This section describes removing, replacing, or installing new sanitary sewer pipe of varying material types. The materials furnished and installed shall conform to the requirements specified herein for the type and class of material named in the plan.

605.2 Materials

- (1) Furnish pipe consistent with the pipe material and diameter bid item indicated in the plan. Base materials and backfilling materials shall conform to City of La Crosse Standard Procedures.
- (2) Unless otherwise directed by the Engineer, all pipe and accessories shall be unloaded at the point of delivery, and hauled to and distributed at the site of the work by the Contractor. The materials shall be at all times handled with care to avoid damage. The material shall not be dropped or bumped against the ground, other pipe and accessories already on the ground, or any other object on the ground.
- (3) The contractor shall furnish random lengths of pipe for each contract as may be required for the proper placement of fittings or structures.
- (4) Unless otherwise specified, references to various standard specifications and test methods shall be understood to mean the specification or test method which is current on the date of awarding of bid.

605.2.1 Remove/Abandon/Replace

- (1) The existing sanitary sewer pipe may consist of PVC, HDPE, PP, clay pipe, ductile iron, concrete pipe, or reinforced concrete pipe.

605.2.2 Poly-Vinyl Chloride Pipe (PVC)

- (1) Solid-wall Poly-Vinyl Chloride (PVC) pipe and fittings, labeled as "PVC" on the plans, shall conform to the requirements of the Specification for Type PSM PVC Sewer Pipe and Fittings, ASTM D-3034, SDR-35 or SDR-26 and ASTM F-679, PS 46 or PS 115. Fittings such as saddles, elbows, tees, wyes, and others shall be of material and construction corresponding to, and have a joint design compatible with the adjacent pipe.
- (2) SDR-35 or PS 46 shall be used in depths up to 15 feet below finished surface. SDR-26 or PS 115 shall be used with depths greater than 15 below finished surface.
- (3) All couplings shall be of a shielded/reinforced style, to prevent sagging, settlement, deformation, etc.
- (4) Rubber gasket conforming to ASTM D 3212 (F477) shall be used. This shall be a bell and spigot joint, sealed by a rubber gasket so that the assembly will remain watertight under all conditions of service, including the movements resulting from the expansion, contraction, settlement and deformation of the pipe.

605.2.3 Tracer Wire

- (1) Provide a 12 AWG XLP insulated, copper, 600 volt AC locate wire through the conduit run. Wire shall be yellow in color. Connect the locate wire by using a silicone filled wire nut at each pull box, vault or other access point. Alternatively, use a single wire through the access points, leaving a 6 foot coil in each pull box, vault or other access point for splicing.

605.2.4 Testing Station

- (1) City shall provide testing station to be provided with each replaced or new sewer lateral. All materials required for the test station shall be incidental to the item.
- (2) The following Copperhead Snakepit testing station models are acceptable for City construction and shall be Green in color. Substitutions shall be approved by the Engineer prior to delivery to the job site.



Testing Station Model	
Testing Station Location	Model Number
Boulevard Grass	LD14*2T-SW
Concrete/Driveway	CD14*2T-SW

605.3 Construction Methods

- (1) The foundations, or bedding, in the trench shall be formed to prevent any subsequent settlement, which might result in excessive pressure and consequent rupture of the pipes. If the foundation is rock, an equalizing bed of concrete or sand shall be placed upon the rock and well compacted. The thickness of these beds shall be not less than four inches. If the foundation is good firm earth, the earth shall be pared or molded to give a full support to the lower third of each pipe, and, if necessary to secure a proper bearing for the pipe, a layer of concrete, fine gravel, or other suitable material shall be placed. The same means of securing a firm foundation shall be adopted in case the excavation has been made deeper than necessary.
- (2) The laying of pipes in finished trenches shall commence at the lowest point and shall proceed towards the upper end, and the pipe shall be laid so that the spigot or tongue ends point in the direction of flow. All pipes shall be laid with ends abutting and true to line and grade. They shall be fitted and matched so that when laid in the work they will form a sewer with a smooth and uniform invert.
- (3) The Contractor is responsible for maintaining line and grade for all pipes laid. The method used shall provide accurate line and grade for the existing construction conditions. The Contractor will be required to re-lay any pipe not installed on proper line or grade.
- (4) New and replaced sanitary sewer pipe shall be televised from structure to structure as described in the City of La Crosse Standard Procedures. Televising shall be incidental to the pipe laying. Dewatering shall be incidental to the pipe laying and is described in the City of La Crosse Standard Procedures.
- (5) Pipe laying must be complete with backfilling and cleanup operations completed or being continued without interruption as a positive requirement before permission is granted to continue excavating and pipe laying in the next block. Cleanup shall include removal of all excess materials, pipe and equipment from the entire street right of way, including boulevards and sidewalks. Backfilling must be completed as specified to allow the Street Department or pavement contractor to repair the street as soon as possible after pipe laying is complete. Backfilling shall be incidental to the pipe laying and is described in the City of La Crosse Standard Procedures.

605.3.1 Removal

- (1) Removal limits are as shown on plans and/or by field markings done by engineer. Any removals or damage caused beyond this point without the engineer's permission will be the responsibility of the contractor to replace at their expense.
- (2) Removals shall include the following but not limited to:
 - A. Equipment to facilitate removal and transport of pipe and soil.
 - B. Removal of pipe and offsite disposal.
 - C. Capping remaining pipe or structure if needed.
 - D. Additional backfill material if needed.

605.3.2 Abandon

- (1) Abandon limits are shown on plans and/or by field markings done by engineer. Any damage caused beyond this point without the engineer's permission will be the responsibility of the contractor to replace at their expense.
- (2) Pipes identified on the plans for abandonment shall be filled with flowable fill as specified on the plans. The pipe shall be bulk headed and completely filled with a slurry like mixture.
- (3) The pipe shall be plugged at the manhole and at the abandonment location.



605.3.3 Replace

- (1) This item shall be used for replacing existing pipe with new PVC pipe when the existing pipe is located within the same trench. Removal of existing sanitary sewer pipe shall be incidental to this item. Connecting fittings shall be incidental to this item.
- (2) Any known sewer lateral within the confines of the trench that is exposed during replacement of the main shall be reconnected and considered incidental to the replaced main.

605.3.4 Sewer Lateral Connections

- (1) Sanitary sewer connections shall be either four (4) or six (6) inch SDR 26 PVC pipe. Sanitary sewer connections shall typically be laid with a maximum grade of one-half (1/2) inch per foot and a minimum grade of one-fourth (1/4) inch per foot, any variations from these standards shall be approved in writing from either the Engineer within the right of way or a City Inspector outside the right of way. The depth of proposed or reconstructed sanitary sewer connections at the property line shall be a minimum of eight (8) feet with an optimum depth of ten (10) feet. Unless otherwise specified, sanitary sewer connections, wyes and tees, shall be of the same material as the sewer main pipe. Where connections are to be connected to risers the Contractor shall furnish and install the required fittings. Saddle style connections are prohibited, full wyes and tees must be used to assure a sealed connection to the sewer main.
- (2) For the installation of a new connection in the public right-of-way, unless otherwise specified in the plans or directed by the Engineer, the size of a newly constructed residential sanitary sewer connection to be installed between the public sanitary sewer main and the property line shall be four (4) inches in diameter. The Engineer may require the size of the connection to be six (6) inches or greater depending on the lot size or proposed land use.
- (3) The depth of the proposed sanitary sewer lateral at the property line shall be a minimum of eight (8) feet or a minimum one (1) percent slope from the sanitary main.
- (4) Sewer laterals shall include tracer wire between the testing station in the boulevard and the sanitary main. Tracer wire and testing station shall be included in the price of the sewer lateral.
- (5) Testing station shall be flush with concrete, brick paver surface, or grass boulevard. Test station location shall be installed at the direction of City staff.
- (6) Sewer laterals being installed on mains with a liner require the removal of the host pipe, direct connection to the liner, and grouting on both ends of the removed section to prevent any voids that may form from the exposed gap between the host pipe and liner.

605.3.5 Sewer Lateral Reconnects

- (1) Reconnect shall include reconstructing sanitary sewer connections that shall be reconnected to the sanitary sewer main. This item shall include necessary wyes and fittings, PVC pipe, four (4) inch or larger, crushed rock bedding and backfill required for the sanitary lateral reconnection. The Contractor shall be responsible for maintaining the normal flow of wastewater during reconnection of the connections.
- (2) Unless otherwise specified in the plans, when a portion of a sanitary sewer lateral in the public right-of-way is to be reconstructed, repaired or replaced, the inside diameter of the new lateral to be installed shall match that of the lateral which is being replaced. All new lateral connections shall be a minimum of four (4) inches in diameter. For purposes of this requirement, all five (5) inch connections shall be considered to be six (6) inches in diameter. It shall not be permissible, in any event, to decrease the diameter of a sanitary sewer connection in the direction of flow.
- (3) Where a sanitary sewer connection is being re-laid in the public right-of-way and bends are required to reconnect the new connection to the ends of the existing connection or sewer main, the Contractor shall use SDR 26 PVC bends that provide a change in the direction of flow of 45 degrees or less. Bends placed in a connection shall be separated by straight pieces of pipe.



Engineering Department

400 La Crosse St., La Crosse, WI 54601 • (608) 789-7505 • Fax: (608) 789-8184
http://www.cityoflacrosse.org

- (4) Where a connection is being re-laid in the public right-of-way and connected to pipes of differing materials and/or sizes, standard flexible couplings shall be used. The couplings to be used shall provide for a water-tight, air-tight fit around the outside diameter of each pipe and shall be securely fastened with two stainless steel bands at each pipe end. Couplings that reduce the pipe cross sectional area in the direction of the flow shall not be allowed. The bedding shall be compacted to provide a solid foundation for the connection such that when backfilling the trench, the lateral does not sag.
- (5) For connections that are in close proximity to terrace trees (as determined by the Engineer), the situation shall be reviewed on a case-by-case basis by the Engineer and the City Parks Department. The Contractor shall use construction methods and equipment to minimize tree damage as directed by the Engineer. In extreme cases the Engineer may elect to terminate connection installation prior to conflict with the tree and a new lateral shall be constructed around the tree.
- (6) The depth of the reconstructed sanitary sewer lateral at the property line shall be a minimum of eight (8) feet or a minimum one (1) percent slope from the sanitary main.
- (7) Live sewer connections that will be reconnected to the sewer main, will be re-laid from the sewer main to competent lateral pipe, or as directed by the Engineer.
- (8) Construction of new lateral connections shall be completed from a point 5 feet behind the curb to the sewer main. Property owners may have laid a sanitary lateral to the property line or have plans (indicated by a permit in the window) to place a lateral. The Contractor shall then construct the new lateral from a point at the right-of-way to the storm sewer main, including connecting to the storm lateral if already provided by the property owners. Removal and saw cutting of sidewalk shall be considered incidental to the cost of the connection.
- (9) Sewer laterals shall include tracer wire between the testing station in the boulevard and the sanitary main. Tracer wire and testing station shall be included in the price of the sewer lateral.
- (10) Testing station shall be flush with concrete, brick paver surface, or grass boulevard. Test station location shall be installed at the direction of City staff.

605.4 Measurement

- (1) The department will measure successfully removed or abandoned sanitary sewer pipe by the lineal foot (LF). The measurement will be based on the plan quantities or field markings by the engineer.
- (2) The department will measure PVC pipe furnished and successfully installed by lineal foot (LF). The measurement will be made on the road from edge of structure to edge of structure.

605.5 Payment

The department will pay for the measured quantity at the contract unit price under the following bid item:

ITEM NUMBER	DESCRIPTION	UNIT
605.01-.04	Remove Sanitary Sewer Pipe (Depth)	LF
605.05-.08	Abandon Sanitary Sewer Pipe (Depth)	LF
606.01-.06	New SDR-26/PS115 PVC Sanitary Sewer Pipe (size)	LF
607.01-.06	New SDR-35/PS46 PVC Sanitary Sewer Pipe (size)	LF
608.01-.02	New SDR-26/PS115 PVC Sanitary Lateral (size)	LF
609.01-.06	Replace SDR-26/PS115 PVC Sanitary Sewer Pipe (size)	LF
610.01-.06	Replace SDR-35/PS46 PVC Sanitary Sewer Pipe (size)	LF
611.01-.02	Replace SDR-26 PVC Sanitary Lateral (size)	LF



605.6 Testing, Acceptance, & Maintenance

- (1) Each pipe shall be carefully inspected and those not meeting the specifications shall be rejected. No pipe shall be laid except in the presence of the Engineer or his authorized inspector, and the Engineer may order the removal and relaying of any pipe improperly installed.
- (2) The cost of all testing by the Contractor shall be included in the unit price for the various size and type of sewer pipe installed. For all tests, the Contractor shall install, backfill and clean all sewer mains and any related appurtenances prior to performing the test.
- (3) All testing by the Contractor shall be performed in the presence of the Engineer. The City may not consider any testing not observed by the Engineer for acceptance.

605.6.1 Infiltration Tests

- (1) **At the request of the Engineer**, the Contractor shall provide infiltration tests on any new or replaced sanitary sewer pipes.
- (2) All leakage tests shall be completed and approved after the sanitary sewers, structures, and appurtenances have been installed, backfilled and cleaned, but prior to the placement of a permanent surface. The leakage test may be either a water infiltration test or a low-pressure air test. The contractor shall furnish all equipment, materials, labor, and other work necessary to complete the tests or provide a qualified, approved Subcontractor. The Contractor may perform either the water infiltration test or low-pressure air test, except as specified below.
- (3) When leakage or infiltration exceeds the amount allowed by the specifications, the Contractor at their expense shall locate the leaks and make necessary repairs or replacements in accordance with the specifications to reduce the leakage or infiltration to the specified limits. Any individually detectable leaks shall be repaired, regardless of the results of the tests.

605.6.1.1 Water Infiltration Test

- (1) If groundwater is encountered in the construction of a section of sewer, the water infiltration test shall be used for the leakage test. After the completion of pipe lines laid below the groundwater level and groundwater conditions have returned to normal, the line shall be tested for water infiltration. A minimum positive head of two (2) feet of groundwater over the top of the pipe shall be available for this test to be considered valid. The Contractor may stimulate this condition, at no cost to the City, by flooding the trenches with prior approval of the Engineer.
- (2) The outlet end of the sewer at the manhole shall be closed sufficiently to prevent the entrance of water, and pumping of groundwater. Pumping shall be discontinued for at least three (3) days after which the section shall be tested for infiltration. The length of the test shall not be less than one (1) hour in duration.
- (3) The rate of infiltration of water into the sewer project, including appurtenances, shall not be in excess of 200 gallons per day per inch diameter per mile of sewer for any section of the system. The infiltration between any two adjacent manholes shall not be greater than 250% of the allowable infiltration rate. The Contractor is required; however, to repair all visible leaks, even if the infiltration requirements are met.
- (4) The infiltration allowances for manholes shall be computed using the total number of vertical feet of manhole subject to infiltration expressed as the equivalent diameter sewer.

ALLOWABLE LIMITS OF INFILTRATION			
Based on 200 gal./in. diam./mile			
Diameter of Sewer Inches	Infiltration per Ft. per Hr. Gallons	Diameter of Sewer Inches	Infiltration per Ft. per Hr. Gallons
4"	0.0063	21"	0.0332
6"	0.0095	24"	0.0378
8"	0.0126	27"	0.0426



Engineering Department

400 La Crosse St., La Crosse, WI 54601 • (608) 789-7505 • Fax: (608) 789-8184
<http://www.cityoflacrosse.org>

10"	0.0158	30"	0.0474
12"	0.0190	36"	0.0568
15"	0.0237	42"	0.0663
18"	0.0284	48"	0.0758
42" Diameter Manhole – 0.0663 Gal. per vertical ft. per hr.			
48" Diameter Manhole – 0.0758 Gal. per vertical ft. per hr.			

- (5) In flood prone areas, new and replacement sanitary sewer systems shall be designed and installed to minimize or eliminate any infiltration of flood waters into the sewer system or exfiltration from the sewer system into the flood waters. Any on-site waste disposal systems shall be designed, located and constructed to avoid impairment to the system or contamination from the system during flooding.

605.6.1.2 Low Pressure Air Test

- (1) If sufficient groundwater is not present to conduct the Water Infiltration Test, the Low Pressure Air Test shall be used for the leakage test. The Contractor shall furnish all materials, equipment, and labor for conduction an air test. The final leakage test shall be conducted in the presence of the Engineer and in accordance with the appropriate ASTM standards.
- (2) Each section of sewer to be tested shall be flushed and cleaned prior to conducting the low pressure air test. This serves to clean out any debris and produces more consistent results.
- (3) Each section of sewer shall be tested between successive manholes by plugging and bracing all openings in the mainline sewer and the upper ends of all house connection sewers. One of the plugs should have an inlet tap, or other provision for connecting a hose to a portable air control source. Air shall be added slowly to the test section until the pressure reaches 4.0 pounds per square inch of gauge pressure (psig). Do not exceed 9.0 psig. After a pressure of 4.0 psig is obtained, the pressure shall be allowed to stabilize between 3.5 psig and 4.0 psig for at least two (2) minutes. This allows the air temperature to stabilize in equilibrium with the temperature of the pipe walls. The pressure will normally drop slightly until the temperature equilibrium is obtained. During this period, all plugs should be checked with a soap solution to detect any plug leakages.
- (4) The test shall begin once the air supply is disconnected and the pressure decreases to 3.5 psig. The time for the pressure to drop 1.0 psig between 3.5 psig and 2.5 psig shall be recorded and compared to the total required test time as found in Table 1 - Low Pressure Air Test Times to determine if the rate of actual air loss is within the allowable limit. In computing the total required test time from Table 1, the required test time for the length and pipe size of any service connections (i.e. laterals) in the test section shall be added to the required test time for the length and pipe size of mainline sewer being tested.
- (5) If the total required test time elapses before the 1.0 psig pressure drop occurs, the test section shall be accepted. If the total required test time does not elapse before the 1.0 psig pressure drop occurs, the air loss rate in the test section shall be considered excessive and the section of pipe shall be considered to have failed the test.
- (6) Upon completions of the air test, the bleeder valve is opened and all air is allowed to escape. Plugs should not be removed until all air pressure in the test section has been released. No one should be allowed in the trench or manhole while the pipe is being decompressed.

Low Pressure Air Test Times									
Test Length (FT)	Pipe Diameter (Inches)								
	4	6	8	10	12	15	18	21	24
25	0:05	0:10	0:18	0:28	0:40	1:03	1:31	2:03	2:41
50	0:09	0:20	0:36	0:56	1:20	2:05	3:01	4:06	5:21
75	0:14	0:30	0:53	1:23	2:00	3:08	4:32	6:09	8:02



Engineering Department

400 La Crosse St., La Crosse, WI 54601 • (608) 789-7505 • Fax: (608) 789-8184
<http://www.cityoflacrosse.org>

100	0:18	0:40	1:11	1:51	2:40	4:10	6:02	8:12	10:42
125	0:23	0:50	1:29	2:19	3:20	5:13	7:33	9:55	11:20
150	0:27	1:00	1:47	2:47	4:00	6:15	8:30	9:55	11:20
175	0:32	1:10	2:04	3:14	4:40	7:05	8:30	9:55	11:20
200	0:36	1:20	2:22	3:42	5:20	7:05	8:30	9:55	11:20
225	0:41	1:30	2:40	4:10	5:40	7:05	8:30	9:55	11:20
250	0:45	1:40	2:58	4:38	5:40	7:05	8:30	9:55	11:53
275	0:50	1:50	3:15	4:43	5:40	7:05	8:30	10:02	13:04
300	0:54	2:00	3:33	4:43	5:40	7:05	8:30	10:57	14:15
325	0:59	2:10	3:47	4:43	5:40	7:05	8:43	11:52	15:26
350	1:03	2:20	3:47	4:43	5:40	7:05	9:24	12:47	16:38
375	1:08	2:30	3:47	4:43	5:40	7:05	10:04	13:41	17:49
400	1:12	2:40	3:47	4:43	5:40	7:24	10:44	14:36	19:00
425	1:17	2:50	3:47	4:43	5:40	7:52	11:24	15:31	20:11
450	1:21	2:50	3:47	4:43	5:40	8:20	12:04	16:26	21:23
475	1:26	2:50	3:47	4:43	5:40	8:47	12:45	17:20	22:34
500	1:30	2:50	3:47	4:43	5:55	9:15	13:25	18:15	23:45

Minimum allowable times (Min:Sec) for loss of air pressure from 3.5 psig to 2.5 psig for size and length of pipe indicated. (Based on 0.003 cfm per square foot with a minimum loss of 2.0 cfm and a maximum of 4.5 cfm.)

605.6.2 Televising

- (1) At the completion of the utility portion of the project, prior to paving operations, the contractor shall provide the City with a digital video record of all new and replaced storm sewers installed. Final acceptance of the new and replaced sewers shall be based on the review of the video record. The televising contractor shall be regularly engaged in televising of sewers and shall provide all equipment necessary to provide the digital video record of the sewers installed.
- (2) The contractor shall televise all sewer pipe from structure to structure when more than 20 feet of the pipe length has been replaced or as directed by the Project Engineer.
- (3) The video equipment used shall be designed specifically for televising sewer and shall have on-board lighting, may be either self-propelled or towed. The camera shall be capable of turning and rotating 360 degrees and shall have magnification to provide a close-up view of the full interior of the sewer pipes including the crown regardless of pipe diameter. The contractor shall provide an on-site heated and cooled enclosure and shall permit the televising to be observed by a representative of the City.
- (4) The Contractor shall lightly clean the sewer pipes prior to televising. No material shall be passed from section to section. All sludge, dirt, sand, rock, grease, roots, and other solid or semi-solid materials resulting from the cleaning operation shall be removed at the upstream or downstream manhole of the section being cleaned. All solids or semi-solids resulting from the cleaning shall be removed from the site by the Contractor on a daily basis. The contractor is responsible for disposing of any materials removed during the cleaning operations.
- (5) The digital video record shall be a digital file in a mpeg format. The file shall show a continuous video of each length of sewer televised. The video shall include the following:
 - A. Date and time when the recording was made.
 - B. Name of the street or location of the sewer including cross streets.
 - C. Type and size of sewer televised.



- D. Distance from manhole to manhole.
- E. Distance from manhole to each sewer wye or tap, and angle at which the wye or tap is connected to the sewer pipe.
- F. Before starting televising the contractor shall provide a sample video recording to the Engineer to confirm that the format is acceptable.

605.6.3 Mandrel Test

- (1) **At the request of the Engineer**, pipe 12 inches and larger shall be tested for acceptance with an approved go-no-go mandrel not less than thirty days after the pipe has been installed, the backfill compacted, and other underground utilities within close proximity (such as water main) have been installed and backfilled but before paving is constructed. For acceptance, the mandrel must pass through the entire section between sewer access structures in one pass when pulled by hand without the use of excessive force.
- (2) The Contractor shall furnish the equipment and labor for making this acceptance test. The mandrel shall be of a shape similar to that of a true circle enabling the gauge to pass through a satisfactory pipeline with little or no resistance. The mandrel shall be of a design to prevent it from tipping from side to side and to prevent debris build-up from occurring between the channels of the adjacent fins or legs during operation. Each end of the core of the mandrel shall have fasteners to which the pulling cables can be attached. The mandrel shall have nine various sized fins or legs of appropriate dimensions for various diameter pipes. Each fin or leg shall have a permanent marking that states its designated pipe size and percent deflection allowable. The diameter of the mandrel shall be equal to ninety-two point five (92.5) percent of the base inside diameter of the pipe. The Contractor shall furnish the engineer a table showing the base inside diameter and the seven point five (7.5) percent deflection mandrel dimension for each pipe diameter called for in the plans. The base inside diameter shall be the minimum pipe inside diameter derived by subtracting the statistical tolerance package (defined below) from the pipe's average inside diameter. 9 point mandrels shall be used by the Contractor for testing:

Nominal Size	Mandrel Size
12 inch Diameter	11.04 inches
15 inch Diameter	13.80 inches
18 inch Diameter	16.57 inches
24 inch Diameter	22.08 inches
30 inch Diameter	27.60 inches
36 inch Diameter	33.12 inches

- (3) Any section of completed pipe failing to pass this deflection test shall be replaced and retested at the Contractor's expense. If base course, pavement, concrete, landscaping, seeding, matting, curb gutter, sidewalk, or driveways have been placed over the pipe, removal and replacement of those items shall also be done at the contractor's expense.



620-SANITARY SEWER STRUCTURE CONSTRUCTION

620.1 General Description

- (1) This section describes replacing or installing new sanitary sewer manholes. The materials furnished and installed shall conform to the requirements specified herein for the type and size of material named in the plan.

620.2 Materials

- (1) Base materials and backfilling materials shall conform to City of La Crosse Standard Procedures.
- (2) Unless otherwise directed by the Engineer, all structures shall be unloaded at the point of delivery, and hauled to and distributed at the site of the work by the Contractor. The materials shall be at all times handled with care to avoid damage. The material shall not be dropped or bumped against the ground, other pipe and accessories already on the ground, or any other object on the ground.
- (3) All materials shall be stored within the roadway limits (back of curb to back of curb).
- (4) All structures to be installed shall include 3 to 10 foot long PVC pipe (SDR 35 or SDR 26) outside of the structure to provide adequate room for connections. The pipe shall conform to City of La Crosse Standard Procedures.
- (5) Mortar specified in the plans shall meet the requirements for Type "M" mortar of the property specification of ASTM Designation C-270. Mortar shall consist of a mixture of clean mason sand, water, and air-entraining cementitious materials.
- (6) Flexible coupling or connection of pipe to the structure shall use FERNCO product or Engineer approved equal. The coupling shall be manufactured to match the outside diameter of each pipe and to align the pipe inverts. The flexible coupling material shall be designed for use on sanitary sewers. The material shall be resistant to chemicals, bacteria, fungus, and gases. The coupling shall be furnished with stainless steel compression bands. FERNCO couplers shall be used for pipe diameters up to 36" in diameter.
- (7) Unless otherwise specified, references to various standard specifications and test methods shall be understood to mean the specification or test method which is current on the date of awarding of bid.

620.2.1 Removal

- (2) The existing sanitary sewer manhole may consist of red brick, block, or precast construction. All manhole components are to be removed and discarded off site except the casting is to be salvaged for the City of La Crosse Sewer Department.

620.2.2 Manhole

- (1) Manholes shall be of precast concrete only. Precast manhole shall be of the size and type shown in the details.
- (2) Precast manholes shall be of reinforced concrete and shall conform to the specifications of Precast Reinforced Concrete Manhole Sections, ASTM C 478. Precast concrete shall contain the Xypex Bio-San C500 additive or approved equal.
- (3) All new or replaced manholes shall be constructed without steps. Cutting of steps out of new manhole sections is prohibited.
- (4) Pick holes shall be sealed on the inside and the outside of the precast structure prior to backfilling the excavation.
- (5) Each precast structure on the plan shall be custom manufactured with factory-made cutouts for sanitary sewer connections. Cutouts shall Not extend into the groove of the bottom section or barrel section. There shall be a minimum of twelve (12) inches of the inside wall of the precast structure present between the cutouts for the pipes. A minimum of two (2) inches of the precast structure must be present between the top of the knockout and the bottom of the adjustment rings. No removal of the precast structure above the precast knockout will be allowed.



- (6) All manhole joints except the upper most joint between the frame and top precast ring shall be free of concrete mortar. Concrete mortar shall be allowed at this joint up to a thickness of $\frac{3}{4}$ inch to achieve final plan grade of the casting. All other joints shall be sealed with flexible butyl rubber gaskets or rope.
- (7) All pipes entering a manhole shall be cut to the proper length. The pipe shall be cut by sawing or other method approved by the Engineer. Breaking the pipe to length with a hammer will not be allowed. The pipe shall be cut so the point in the pipe, which extends least into the manhole or catch basin, is flush with the inside wall of the manhole or catch basin, plus or minus one inch. A flexible boot shall be used to connect the pipe to the manhole.
- (8) Manhole inverts shall be poured with 3500-psi concrete (minimum 28-day strength) with $\frac{3}{4}$ inch maximum aggregate size. Inverts shall be filleted to provide a smooth flow line through the manhole, with the radius of the "trough" formed matching that of the pipe. The fillets shall extend half way up the pipe on each side of each pipe and slope upward to the sides of the manhole. The invert shall be poured directly on the concrete base of the manhole. Where the invert elevation is below the ground water table, the minimum thickness of the invert shall not be less than 4 inches.
- (9) All Manhole structures over 48" inside diameter shall be constant diameter to the top of the structure. The structure top shall have a concrete top with a 27" diameter centered opening for the manhole casting.

620.2.3 Class "W" Manhole

- (1) Manholes may be designated as class "W" in areas of known high water or designated by the Engineer. Class "W" manholes' inlet and outlet pipes shall be joined to the manhole with a gasketed flexible watertight connection or any watertight connection arrangement that allows differential settlement of the pipe and manhole wall.
- (2) Manhole joint seal shall be minimum of nine (9) inches wide. The seal shall consist of flexible rubberize seal conforming to ASTM C923 held in place with stainless steel compression bands or butyl adhesive tape conforming to ASTM C877. Products are subject to pre-approval by the Engineer.

620.2.4 Outside Drop

- (1) Pipe material and fittings shall be PVC to conform to ASTM D 3034 (F679). Pre-cast concrete horseshoe shall be filled with $\frac{3}{4}$ " washed stone.
- (2) Outside drop shall be required for all incoming pipes that are over 18" above the spring line of the outgoing sewer pipe.

620.2.5 Concrete Rings

- (1) Concrete adjusting rings shall be provided with reinforcement.
- (2) Concrete rings shall be of standard size of 2 or 4-inch thickness at the following standard-sized diameter rings.
 - A. Manhole – 27" diameter opening
- (3) Mortar used between top ring and casting shall follow ATM C-270 Specification.

620.2.6 Concrete Top

- (1) Concrete Top shall be of precast concrete and concentric top only. Precast structure shall be of the size and type shown in the details.
- (2) Precast concrete top shall be of reinforced concrete and shall conform to the specifications of Precast Reinforced Concrete Manhole Sections, ASTM C 478. Precast concrete shall contain the Xypex Bio-Scan C500 additive or approved equal.
- (3) The Concrete top joint shall be free of concrete mortar. Concrete mortar shall be allowed at the joint between the concrete top and the casting up to a thickness of $\frac{3}{4}$ inch to achieve final plan grade of the casting. All other joints shall be sealed with flexible butyl rubber gaskets or rope.

620.2.7 Concrete Cone

- (1) Concrete Cone shall be of precast concrete only. Precast structure shall be of the size and type shown in the details. Concrete cone shall be concentric type only.



Engineering Department

400 La Crosse St., La Crosse, WI 54601 • (608) 789-7505 • Fax: (608) 789-8184
<http://www.cityoflacrosse.org>

- (2) Precast concrete cone shall be of reinforced concrete and shall conform to the specifications of Precast Reinforced Concrete Manhole Sections, ASTM C 478. Precast concrete shall contain the Xypex Bio-Scan C500 additive or approved equal.
- (3) The Concrete cone joint shall be free of concrete mortar. Concrete mortar shall be allowed at the joint between the concrete top and the casting up to a thickness of ¾ inch to achieve final plan grade of the casting. All other joints shall be sealed with flexible butyl rubber gaskets or rope.

620.2.8 Casting

- (1) Existing Castings shall be salvaged, set aside in an easily accessible area to be reused or delivered to the municipal storage unit. All new castings shall be provided by the City of La Crosse Sewer Department if needed. The Contractor shall provide new castings if specified in the Specifications, plans, or as requested by the Engineer.
- (2) The castings for manholes shall be in accordance with the designs, dimensions, and details shown on the Standard Detail Drawings for the installation named, unless otherwise specified. Frames and covers for manholes shall be machined and fitted so that rocking and chattering will be eliminated.
- (3) Gray iron castings used in the work shall conform to the requirements of the Specifications for Gray Iron Castings, ASTM A 48, Class 30.
- (4) The following Neenah Foundry castings are acceptable for City construction and are further detailed in the Standard Detail Drawings. Substitutions shall be approved by the Engineer prior to delivery to the job site.

City of La Crosse Standards				
Type	Cat #	Comp #		Notes
Manhole: Sanitary	R-1670-A	Frame	1670-2004	T-SEAL/NO ROCK "SANITARY" LABEL LID
		Lid	1670-0348	
Manhole: Sanitary 4"	R-1689	Frame	1689-2301	T-SEAL/NO ROCK ONLY TO BE USED WITH THE APPROVAL OF THE SEWER SUPERINTENDENT
		Lid	1689-1550-0050	

620.3 Construction Methods

- (1) The contractor shall be responsible for the accurate transfer of all construction alignment and grades from the primary line and grade as established by the Engineer. In addition, the Contractor shall supply, at his own cost, and have available on site, the proper surveying equipment for the transfer of grades. If a laser is used during piping, a transit will be required to establish the alignment.
- (2) The Contractor shall follow Standard Procedures for site preparation and excavation.
- (3) The Contractor shall place minimum of six (6) inches of bedding material prior to placement of manhole structure.
- (4) The Contractor shall construct manhole structures at the location and grade conforming to the requirements as shown on the Plans and Details.
- (5) Excavation shall be limited to the size required for the proposed structure. All undesirable material which cannot adequately support the structure shall be removed below the normal bottom and replaced with crushed stone.
- (6) Structures shall be backfilled in one-foot lifts, and compacted with special mechanical compactors as approved by the Engineer, to achieve 95% of the modified proctor density.
- (7) Total height adjustment shall be a minimum of three (3) inches and a maximum of nine (9) inches.

620.3.1 Removal

- (1) Removal limits are as shown on plans and/or by field markings done by engineer. Any removals or damage caused beyond this point without the engineer's permission will be the responsibility of the contractor to replace at their expense. Casting shall be set aside in an easily accessible area or delivered to municipal storage unit.
- (2) Removals shall include the following but not limited to:
 - A. Equipment to facilitate removal and transport of manhole and soil.



- B. Removal of manhole and offsite disposal.
- C. Capping remaining pipe if needed.
- D. Additional Backfill material if needed.

620.3.2 Manhole

- (1) The proposed manhole elevations are shown on the project plans. Actual manhole build shall be less the casting and adjusting rings as shown on the details. This will allow for any field adjusting as deemed necessary by the Engineer.
- (2) Manhole casting final adjustment shall utilize City of La Crosse Standard Procedures Core and Pour Finishing, during full pavement replacement operations.
- (3) Manhole casting final adjustment shall utilize City of La Crosse Standard Procedures Adjust Structure, during pavement overlay operations.
- (4) Manhole casting shall be held to a maximum of 3/8" below pavement surface.

620.3.3 Class W Manhole

- (1) Manholes may be designated as class "W" in areas of known high water or designated by the Engineer. Class "W" manholes' inlet and outlet pipes shall be joined to the manhole with a gasketed flexible watertight connection or any watertight connection arrangement that allows differential settlement of the pipe and manhole wall.
- (2) The joints between the manhole casting and cone section or flat-top shall be sealed with an internal or external flexible rubber seal. An external flexible rubber seal shall be utilized on all newly constructed manholes. Internal flexible rubber seals shall only be used on sewer renovation projects with pre-approval by the Engineering Department. A bead of butyl rubber caulk shall be applied to the lower sealing surface of the rubber sleeve to fill minor irregularities.
- (3) All manhole joints except the upper most joint between the casting and top precast ring shall be free of concrete mortar. Concrete mortar shall be installed at this joint up to a thickness of ¼ inch to achieve final plan grade of the casting. All other joints shall be sealed with flexible butyl rubber gaskets or rope.
- (4) Manhole casting shall be held to a maximum of 3/8" below pavement surface.

620.3.4 Outside Drop

- (1) Whenever shown on the plans, or directed by the Engineer, the Contractor shall install outside drop structures in conjunction with the installation of sanitary manholes as detailed in the City of La Crosse Standard Detail.
- (2) The pipe and fittings to be used in the construction of the outside drop inlets shall be of the same material as the sewer main. The pipe and fittings shall be securely anchored to the manhole to prevent displacement during the placement of the concrete encasement. The pipe and fittings shall be securely anchored using a pre-cast concrete horseshoe to prevent displacement during backfilling operations.
- (3) The new pipe that is installed shall be considered incidental to this bid item. The pouring and construction of concrete bench and flow lines shall be considered a part of this work. The contractor shall be responsible for maintaining the normal flow of wastewater during connection to the manhole or install temporary bypass.

620.3.5 Concrete Rings

- (1) All rings are to be installed per City of La Crosse Standard Detail.
- (2) Contractor shall use the least number of rings possible to bring casting to within twelve (12) inches of final grade.
- (3) Concrete rings shall be separated with flexible butyl rubber gaskets or rope.
- (4) A minimum thickness of ½ inch of mortar shall be placed and maintained between the adjusting rings and the casting.
- (5) The remaining 12 inches of adjustment (which includes the casting) shall be part of core and pour finishing or adjust structure. These items are described in the City of La Crosse Standard Procedures.
- (6) No manhole casting shall be adjusted without the Engineer or City Inspector present.



Engineering Department

400 La Crosse St., La Crosse, WI 54601 • (608) 789-7505 • Fax: (608) 789-8184
<http://www.cityoflacrosse.org>

620.3.6 Replacement

- (1) This item shall follow construction methods for removal and new installation. This item shall also include removal of existing sanitary sewer structure. Removal of existing structure shall be incidental to this item.
- (2) Existing Casting shall be salvaged.

620.4 Measurement

- (1) The department will measure each (EA) manhole successfully removed or furnished and installed.
- (2) The department will measure each (EA) drop structure successfully furnished and installed.

620.5 Payment

The department will pay for the measured quantity at the contract unit price under the following bid item:

ITEM NUMBER	DESCRIPTION	UNIT
620.01-07	Remove Sanitary Manhole (Depth)	EACH
621.01-07	New Standard Pre-Cast Concrete Manhole (Depth)	EACH
622.01-07	Replace Standard Pre-Cast Concrete Manhole (Depth)	EACH
623	Outside Drop	EACH

620.6 Testing, Acceptance, & Maintenance

- (1) The Engineer shall review shop drawings for all new manholes. The Engineer shall have five (5) business days to review and provide the Contractor with any required changes or modifications. The Contractor shall make the required changes at no additional cost. The precast shop drawing and delivered structure shall be approved by the Engineer prior to installation.



625-REPAIR/MODIFY EXISTING STRUCTURE

625.1 General Description

- (1) The following items are to be used when modifying or repairing existing structures or connecting new pipe to existing structures.

625.2 Materials

- (1) All equipment and materials used for repairs or modification to existing sanitary sewer structures shall conform to City of La Crosse Standard Procedures Excavation, Bedding, & Backfill, Sanitary Sewer Pipe, and Structure Construction.

625.3 Construction Methods

625.3.1 Connect to Existing

- (1) Connecting pipe up to 12" diameter PVC

In locations where a new sanitary sewer line is proposed or an existing sanitary sewer line is to be replaced with a larger diameter pipe, the Contractor shall core drill the existing manhole at the proposed line, grade, and diameter indicated on the plans or in the specifications. The diameter of the hole cored shall be sized to accept a flexible pipe-to-manhole boot. The contractor shall core the manhole 4" larger than the connecting pipe diameter and install a boot.

- (2) Connecting larger diameter PVC

The Contractor shall cut a square opening using a saw. The pipe shall be sealed with a water stop gasket and mortar to fill the voided space around the pipe from both sides of the structure wall to ensure a full watertight seal.

650.3.2 Adjust Structure

- (1) Adjusting manhole structures shall be considered incidental to the appropriate manhole work as specified in other sections when constructing new or replaced structure with the same contract. This item shall be called out in the project plans and used when modifying an existing structure.
- (2) Existing Castings shall be salvaged, set aside in an easily accessible area to be reused or delivered to the municipal storage unit.
- (3) The Contractor shall provide necessary concrete rings, flexible butyl rubber gaskets or rope, and mortar.
- (4) All new castings shall be provided by the City of La Crosse Sewer Department if necessary. The Contractor shall provide new castings if specified in the Specifications, plans, or as requested by the Engineer that shall conform to the City of La Crosse Standard Procedures.
- (5) Final casting placement shall conform to the finished crown of the road.

625.3.3 Replace Rings

- (1) Ring adjustment shall be considered incidental to the appropriate manhole work as specified in other sections when constructing new or replaced structure with the same contract. This item shall be called out in the project plans and used when modifying an existing structure.
- (2) Ring replacements are to be made with the fewest number of rings possible.
- (3) Ring replacements are to conform to the City of La Crosse Standard Procedures.
- (4) Existing Castings shall be salvaged, set aside in an easily accessible area to be reused or delivered to the municipal storage unit.
- (5) The Contractor shall provide necessary concrete rings, flexible butyl rubber gaskets or rope, and mortar.
- (6) All new castings shall be provided by the City of La Crosse Sewer Department if necessary. The Contractor shall provide new castings if specified in the Specifications, plans, or as requested by the Engineer that shall conform to the City of La Crosse Standard Procedures.



Engineering Department

400 La Crosse St., La Crosse, WI 54601 • (608) 789-7505 • Fax: (608) 789-8184
<http://www.cityoflacrosse.org>

(7) Final casting placement shall conform to the finished crown of the road.

625.3.4 Replace Cone

- (1) Concrete Cone Replacement shall be considered incidental to the appropriate manhole work as specified in other sections when constructing new or replaced structure with the same contract. This item shall be called out in the project plans and used when modifying an existing structure.
- (2) Existing Castings shall be salvaged, set aside in an easily accessible area to be reused or delivered to the municipal storage unit.
- (3) The Contractor shall provide necessary concrete rings, flexible butyl rubber gaskets or rope, and mortar.
- (4) All new castings shall be provided by the City of La Crosse Sewer Department if necessary. The Contractor shall provide new castings if specified in the Specifications, plans, or as requested by the Engineer that shall conform to the City of La Crosse Standard Procedures.
- (5) Final casting placement shall conform to the finished crown of the road.

625.3.5 Replace Top

- (1) Concrete Top Replacement shall be considered incidental to the appropriate manhole work as specified in other sections when constructing new or replaced structure with the same contract. This item shall be called out in the project plans and used when modifying an existing structure.
- (2) Existing Castings shall be salvaged, set aside in an easily accessible area to be reused or delivered to the municipal storage unit.
- (3) The Contractor shall provide necessary concrete rings, flexible butyl rubber gaskets or rope, and mortar.
- (4) All new castings shall be provided by the City of La Crosse Sewer Department if necessary. The Contractor shall provide new castings if specified in the Specifications, plans, or as requested by the Engineer that shall conform to the City of La Crosse Standard Procedures.
- (5) Final casting placement shall conform to the finished crown of the road.

625.4 Measurement

- (1) The department will measure each (EA) Sanitary Manhole connection successfully completed.
- (2) The department will measure inch (IN) of height of rings replaced and acceptably completed. Contractor shall allow city inspector a visual inspection of the rings prior placement of the casting. Uninspected rings will not be measured for payment.
- (3) The department will measure each (EA) concrete top successfully furnished and replaced.
- (4) The department will measure each (EA) cone successfully furnished and replaced.
- (5) The department will measure each (EA) Sanitary structure successfully adjusted to final elevation.

625.5 Payment

The department will pay for the measured quantity at the contract unit price under the following bid item:

ITEM NUMBER	DESCRIPTION	UNIT
625	Core & Boot Connection to Existing Manhole	EACH
626	Replace Rings	IN
627	Replace Top of Manhole	EACH
628	Replace Manhole Cone	EACH
629	Adjust Existing Manhole Structures to Final Elevation	EACH

625.6 Testing, Acceptance, & Maintenance

N/A



630-SEWER LINER (CIPP)

630.1 General Description

- (1) This section describes installing a Cured in place pipe (CIPP) sewer liner within existing, deteriorated pipe. The materials furnished and installed shall conform to the requirements specified herein for the type and size of material named in the plan.
- (2) Items of work associated shall include, but not limited to, the following:
 - A. Mobilization, site preparation, and applicable permits.
 - B. Televising of sanitary sewer to determine installed conditions.
 - C. Cleaning of existing sanitary sewers to condition necessary for proper installation of product.
 - D. Determining if existing service connections are active or inactive.
 - E. Placement of lining material within sanitary sewer.
 - F. Removing and resetting manhole cones/tops and pavement restoration
 - G. Flow control, including bypass pumping, if required.
 - H. Reinstatement and reconnection of active service connections.
 - I. Sewer testing, internal inspections of installation, and post lining record video.
 - J. Cleanup.
 - K. Other appurtenant and incidental work.

630.1.1 Referenced Documents

- (1) This specification references ASTM standards and other related standards, which are made a part hereof by reference and shall be the latest edition thereof.

ASTM Standard F 1216	Practice for Rehabilitation of Existing Pipelines and Conduits by the Inversion and Curing of a Resin-Impregnated Tube
ASTM Standard F 1743	Practice for Rehabilitation of Existing Pipelines and Conduits by the Pull in and Inflate and Curing of a Resin-Impregnated Tube
ASTM Standard F 2019	Practice for Rehabilitation of Existing Pipelines and Conduits by the Pulled in Place Installation of Glass Reinforced Plastic (GRP) Cured-in-Place Thermosetting Resin Pipe (CIPP)
ASTM Standard D 543	Practices for Evaluating the Resistance of Plastics to Chemical Reagents
ASTM Standard D 638	Test Method for Tensile Properties of Plastics
ASTM Standard D 790	Test Methods for Flexural Properties of Unreinforced and Reinforced Plastics and Electrical Insulating Materials
ASTM Standard D 903	Test Method for Peel or Stripping Strength of Adhesive Bonds
ASTM Standard D 1600	Terminology for Abbreviated Terms Relating to Plastics
ASTM Standard D 3567	Practice for Determining Dimensions of "Fiberglass" (Glass-Fiber-Reinforced Thermosetting Resin) Pipe and Fittings
ASTM Standard D 3839	Guide for Underground Installation of "Fiberglass" (Glass-Fiber Reinforced Thermosetting-Resin) Pipe
ASTM Standard D 5813	Specification for Cured-In-Place Thermosetting Resin Sewer Piping Systems
ASTM Standard E 797	Practice for Measuring Thickness by Manual Ultrasonic Pulse-Echo Contact Method
ASTM Standard F 412	Terminology Relating to Plastic Piping Systems National Association of Sewer Service Companies (NASSCO) "Recommended Specifications for Sewer Collection Rehabilitation"

630.1.2 Submittals

- (1) The Contractor shall not install materials or equipment, which requires submittals, until reviewed by the Engineer. The Engineer's review will be completed as quickly as possible, but may require up to ten (10) working days from the date the submittals are received until they are sent to the Contractor.
- (2) The Contractor shall submit the following materials to the Engineer:



Engineering Department

400 La Crosse St., La Crosse, WI 54601 • (608) 789-7505 • Fax: (608) 789-8184
<http://www.cityoflacrosse.org>

A. Product Data.

1. Manufacturer's product literature and application, installation and recommended repair (patching) requirements for materials used in liner.
2. Manufacturer's product certification of conformance to ASTM Standards for materials used in liner.
3. Manufacturer's Wet Out Report including raw resin data for each liner to be installed and the Manufacturer's recommended curing procedure.
4. Two (2) copies of Liner Pipe Thickness Design Calculations. The design calculations shall be in accordance with Appendix X.I of ASTM F 1216. The liner thickness calculations shall assume the physical properties stated in Section 652.2.4 of these specifications. Proposed CIPP flow capacity calculations.
5. Test results from previous field installations of the same resin system and tube materials as proposed for the actual installation.
6. No liner will be approved for installation until the City has returned one (1) set of approved design calculations to the Contractor.
7. Compensation for all work required for the submittal of product data shall be considered incidental to the project.

B. Digital Video.

1. Submit digital video of cleaned pipes in pre-lining condition.
2. Submit digital video of pipes in post-lining condition showing reinstated and grouted service connections.

C. Sewage Bypassing Plan.

- A. Submit proposed plan for bypassing sanitary sewage during liner installation. Plan shall be to scale and shall show location of existing City sewer access structures.

D. Traffic Control Plan.

- A. Submit proposed plan for Traffic Control during liner installation. Plan shall be to scale, shall show location of existing City sewer access structures, and be in accordance to the Contract document requirements.

E. Public Notifications.

- A. Submit proposed public notification letter and door hangers. Notifications shall be in accordance to Section 625.1.3.E Public Notification.

630.1.3 Requirements of Contractor

(1) Experience

- A. The installer shall have installed a minimum of 200,000 lineal feet of the approved lining material.

(2) Safety.

- A. The Contractor agrees to perform all work under this contract in accordance with local, state and federal safety regulations. This includes, but is not limited to, evaluation of the atmosphere to determine the presence of toxic or flammable vapors or lack of oxygen prior to entering access areas such as sewer access structures and performing inspection or cleaning operations and the use of confined entry equipment for all entries.

(3) Bypassing Pumping.

- A. The Contractor shall follow directions in the City of La Crosse Standard Procedures By-Pass Pumping.
- B. Provide for flow of sewage around sections of pipe to be lined.
- C. One stretch of pipe at a time (manhole to manhole) shall be installed unless otherwise approved by the Engineer.
- D. It shall be the responsibility of the Contractor to notify individuals and businesses whose sanitary sewer will be interrupted during pipe lining operations. It shall be the responsibility of the Contractor to provide necessary service to businesses affected by the lining operation.

(4) Water for Cleaning and Inversion/Installation of CIPP.

- A. The Contractor shall furnish water for cleaning and flushing the existing sewer pipe and for inversion and installation of the CIPP. Contractor shall obtain water from the City Water Utility. All hydrant use must be pre-



approved by the City Water Utility. Contractor shall obtain a permit from the City Water Utility and shall properly utilize back-flow prevention and/or other hydrant access device supplied by and installed onto hydrant by the City Water Utility. The Contractor shall pay all costs associated with coordinating and obtaining water for the cleaning, flushing and inversion operations, including the cost of any cold-weather insulation required at the hydrant access device.

(5) Disposing of Debris.

A. Contractor shall be responsible for disposing of debris removed from sewers at a licensed disposal facility. The Contractor shall pay all costs associated with the transport and disposal of such debris.

(6) Public Notification.

A. Contractor shall make every effort to maintain service usage throughout the duration of the project. In the event that a service needs to be taken out of service, the maximum amount of time allowed for the service interruption shall be 8 hours for any property served by the sewer. The Contractor shall implement a public notification program that shall, at a minimum, require the Contractor to be responsible for contacting all tenants and owner of each home or business connected to the sanitary sewer and informing them of the work to be conducted and the date, time and length of service interruption.

B. The Contractor shall prepare and submit written notice describing the work to be performed for the Engineer to review. Upon acceptance by the Engineer, the notice shall be delivered to each home or business a minimum of seven (7) days prior to the beginning of work being conducted on the pipe section. Door hangers shall also be placed at effected properties between no later than 24 hours and no earlier than 72 hours prior to the sewer service interruption. All notices shall also contain a local (or toll free) telephone number of the Contractor that property owners can use to discuss the project or any problems that arise during installation of the liner. Contractor shall also arrange meetings with any occupants whose service cannot be reinstated within the time referenced in the written notice. Any related costs such as hotel expenses or residential bypass pumping are the responsibility of the Contractor.

C. The City shall provide the Contractor with names and addresses of effected property owners and tenants within the project limits.

630.2 Materials

630.2.1 General Requirements.

(1) The resins, fabric tube, tube coatings, or other materials shall produce CIPP that meets the requirements of these specifications.

(2) All materials, shipped to the project site, shall be accompanied by test reports certifying that the material conforms to the ASTM standards listed herein. Each tube to be installed shall be accompanied by the manufacturer's Wet Out Report detailing the raw resin data and the recommended curing procedure. Materials shall be shipped, stored, and handled in a manner consistent with written recommendations of the CIPP system manufacturer to avoid damage. Damage includes, but is not limited to, gouging, abrasion, flattening, cutting, puncturing, or ultra-violet (UV) degradation. All damaged materials shall be promptly removed from the project site at the Contractor's expense and disposed of in accordance with all current applicable agency regulations.

630.2.2 Tube.

(1) For Heat Cure CIPP systems, the tube material shall meet the requirements of ASTM F 1216 and ASTM D5813, or better. The tube shall consist of one or more layers of flexible needled felt or an equivalent nonwoven or woven material, or a combination of nonwoven and woven materials, capable of carrying resin, withstanding installation pressures and curing temperatures. The tube shall be compatible with the resin system used. The material shall be able to stretch to fit irregular pipe sections and negotiate bends. The outside layer of the tube shall be plastic coated with a material that is compatible with the resin system used. The tube shall be fabricated to a size that,



when installed, will tightly fit the internal circumference and the length of the original conduit. Allowance shall be made for circumferential stretching during inversion.

- (2) Seams in the tube shall be stronger than the non-seamed material.
- (3) For any tube installed, the wall color of the interior pipe surface of CIPP after installation shall be a light reflective color so that a clear detailed examination with closed circuit television inspection equipment may be made.

630.2.3 Resin.

- (1) For Heat Cured CIPP Systems, the resin system shall meet the structural and chemical resistance requirements of ASTM F 1216 and/or ASTM F 1743, or better. A general purpose, unsaturated, styrene-based, thermoset resin and catalyst system or an epoxy resin and hardener that is compatible with the inversion process shall be used. The resin must be able to cure in the presence of water and the initiation temperature for cure shall be less than 180°F (82.2°C).

630.2.4 Reinforcing Material

- (1) Non-Woven, needle interlocked polyester felt formed into sheets of required thickness.
 - A. Felt tubes may be made of single or multiple layer construction; with any layer not less than 1.5 mm thick.
 - B. Mechanical strengthener membrane or strips may be sandwiched in between layers where required to control longitudinal stretching.
 - C. Polyurethane membrane used during inversion of tube may be left on internal surface of liner after curing.
 - D. Minimum thickness of bonded polyurethane membrane and inner liner, if used shall be 0.25 mm, +5%, and shall not affect structural dimension requirements of cured liner.
- (2) Felt Content
 - A. Content shall ensure cured thickness of liner as specified.
 - B. Thickness of cured liner to be as specified (+10%-4%) and shall not include thickness of polyurethane inner liner.

630.2.5 Structural Requirements: Cured-in-Place Pipe (CIPP).

- (1) The required structural CIPP wall thickness shall be in accordance with the Design Equations in Appendix XI of ASTM F 1216 and based on the following physical properties:
 - A. Existing pipe is a "fully deteriorated pipe"
 - B. Minimum ovality of host pipe shall be 5%
 - C. Enhancement factor (K) shall not be greater than 7.0
 - D. Minimum design safety factor shall be 2.0
 - E. Flexural modulus of elasticity shall be reduced by 50% to account for long term.
 - F. Creep retention factor 33%
 - G. Minimum service life 50 years
- (2) The CIPP design shall assume no bonding to the original pipe wall.
- (3) The Contractor must have performed long-term testing for flexural creep of the CIPP material installed by his/her Company. Such testing results are to be used to determine the long-term, time dependent flexural modulus to be utilized in the product design. This is a performance test of the materials (Tube and Resin) and general workmanship of the installation and curing. A percentage of the instantaneous flexural modulus value (as measured by ASTM D 790 testing) shall be used in design calculations for external buckling. The percentage, or the long-term creep retention value utilized, shall be verified by this testing. Values in excess of 50% shall not be applied unless substantiated by qualified third party test data. The materials utilized for the contracted project shall be of a quality equal to or better than the materials used in the long-term test with respect to the initial flexural modulus used in Design.
- (4) The bond between the layers of the cured CIPP shall be strong and uniform. It shall not be possible to separate any two layers with a probe or point of a knife blade so that the layers separate cleanly or the probe or knife blade



moves freely between the layers. If separation of the layers occurs during testing of field samples, new samples will be cut from the work. Any reoccurrence shall cause rejection of the work.

- (5) Any layers of the tube that are not saturated with resin prior to insertion into the existing pipe shall not be included in the structural CIPP wall thickness computation.
- (6) The CIPP system shall have as a minimum the initial structural properties as listed below.

Minimum Physical Properties

Property	Test Method	Cured Composite (min per ASTM F1216)	Cured Composite (400,000 psi Resin)
Flexural Modulus	ASTM D-790	2500,000 psi	400,000 psi
Flexural Strength	ASTM D-790	4,500 psi	4,500 psi

- (7) These physical strength properties shall be determined in accordance with Section 630.2.

630.2.6 Grout: Chemical Grout to Seal Service Connections.

- (1) The chemical grout shall be of a type, which has a documented record of satisfactory performance in sewer usage. All grouting materials shall be delivered to the job site in the original, labeled, and unopened containers. The chemical grout(s) selected by the Contractor is/are subject to approval of the Engineer.

630.2.7 End Seal at CIPP Liner and Manhole

- (1) Each CIPP liner shall terminate at the manhole with a special end seal manufactured by LMK Industries. End seal materials shall be made from a rubber material designed to be installed in sanitary sewers. The compression bands and hardware shall be of 304 or 316 stainless steel.

630.2.8 Testing Requirements.

- (1) Chemical Resistance - The CIPP shall meet the chemical resistance requirements of ASTM F 1216. CIPP samples for testing shall be of the same tube and resin system as that proposed for actual construction. It is required that CIPP samples with and without plastic coating meet these chemical-testing requirements.
- (2) Hydraulic Capacity - The Contractor shall provide calculations that demonstrate that the liner pipe shall have at least 100% of full flow capacity of the original pipe before rehabilitation in a full gravity flow condition. Calculated capacities may be derived using a commonly accepted roughness coefficient for the original pipe material. A typical roughness coefficient of the liner pipe shall be as verified by third party test data.
- (3) Field Samples - The Contractor shall submit test results from previous field installations of the same resin system and tube materials as proposed for the actual installation. These test results must verify that the CIPP physical properties specified in Table above have been achieved in previous field applications.

630.3 Construction Methods

630.3.1 Cleaning of Sewer Lines

- (1) It shall be the responsibility of the Contractor to completely clean each sanitary sewer prior to lining. The work shall consist of providing all labor, materials, power, utilities and equipment necessary to thoroughly clean identified sewers and restore them to 95% of their original carrying capacity.
- (2) Sewer cleaning shall be conducted in accordance with "Recommended Specifications for Sewer Collection Rehabilitation," published by the National Association of Sewer Service Companies (NASSCO). Cleaning Equipment is to be truck-mounted combination jetter/vacuum machines able to thoroughly remove dirt, grease, roots, encrustations, rocks, sand and other materials and thoroughly clean the sewer lines prior to installation of the pipe liner. The cleaning equipment shall move debris to the downstream manhole of the line being cleaned. All material resulting from the cleaning operation shall be removed by vacuum at the downstream manhole of the section being cleaned. Passing material from manhole section to manhole section shall not be permitted. If any debris is passed downstream, the Contractor shall clean the affected section(s) of sewer main at no additional cost to the City.



- (3) If inspection reveals an obstruction that cannot be removed by conventional sewer cleaning equipment, the Contractor shall immediately notify the Project Engineer. The Project Engineer shall determine if the obstruction is able to be removed by sewer cleaning equipment. The Contractor shall remove or repair offset joints, protruding services, or collapsed pipe that will prevent insertion of liner, as determined from the pre-lining video. The Contractor shall receive additional payments for additional excavation spot repairs required due to further deterioration of the pipe. The City reserves the right to delete the lining on any particular manhole-to-manhole pipe section.

630.3.2 Inspecting and Televising Pipelines

- (1) It is the responsibility of the Contractor to inspect all sanitary sewers to be lined using closed-circuit television prior to installation of the CIPP and again following the reinstatement and grouting of all service connections. Experienced personnel trained in locating breaks, obstacles, and service connections by closed circuit television shall perform inspection. The interior of the pipeline shall be carefully inspected to determine the location of any conditions that may prevent proper installation of the impregnated tube, such as protruding service taps, collapsed or crushed pipe, and significant reductions in the cross sectional area. The Contractor shall immediately notify the Project Engineer of any conditions that prevent the proper installation of the CIPP.
- (2) The Contractor shall utilize a closed-circuit television video system that is capable of capturing, producing and recording color digital video of the sewer inspection. The Contractor shall provide color digital video for each sanitary sewer segment designated by the project plans. The video system shall have the capability of capturing or transferring the color video to an MPEG digital format compatible with personal computers.
- (3) All inspections shall follow the Pipeline Assessment and Certification Program (PACP) protocol as established by the National Association of Sewer Service Companies (NASSCO). The inspecting, televising and video recording equipment used on the project shall be the Contractor's choice provided it meets the following minimum requirements:
 - A. The camera, transporter and winch system shall have the ability to continuously inspect and televise at least 600 linear feet of pipe. The inspecting, televising and video recording equipment shall be mounted in a self-propelled van or truck that is capable of moving from location to location. The van or truck shall have markings painted on it indicating the name of the Contractor.
 - B. The camera head shall have pan and tilt capabilities in order to examine pipe defects. The camera shall have an adequate lighting system that clearly illuminates the entire circumference of the pipe segment under inspection. The equipment shall have hardware and software that is compatible with the camera and capable of electronically recording and saving pipe inspection information with software that follows NASSCO PACP inspection protocol.
- (4) A digital video and corresponding log (hard copy and electronic format compatible with other NASSCO PACP certified software) of the conditions present in the pipe sections before installation of the liner shall be made and kept for later reference and delivery to the City.
- (5) Each digital video segment shall be named according to the "upstream structure number-downstream structure number.mpg" format. The digital video shall document in a clear and continuous manner the condition of the sewer segment from the upstream structure to the downstream structure. No interruptions or missing segments shall be allowed unless noted in writing by the City's Project Engineer. The City will reject any digital video that has foggy or static conditions on it. The video shall display on a continuous basis the sanitary sewer pipe footage, continuous video footage along total length, street or address of the sewer segment, the upstream and downstream manhole number for the sewer segment being televised, the sewer pipe diameter and the date of the televising.

630.3.3 Installation

- (1) The CIPP installation shall be in accordance with ASTM F 1216 for Heat Cure CIPP systems.
- (2) Resin Impregnation



Engineering Department

400 La Crosse St., La Crosse, WI 54601 • (608) 789-7505 • Fax: (608) 789-8184
<http://www.cityoflacrosse.org>

- A. A certified Wet Out Report shall be completed, signed, and submitted for each liner delivered to the site. The Wet Out Report shall include, but is not limited to, wet-out date, resin identification, resin weight, resin admixtures, fabric tube length, diameter, and thickness.
 - B. Resin and catalyst system compatible with requirements of this method shall be used. Quantities of liquid thermosetting materials shall be to manufacturer's standards to provide lining thickness required.
 - C. Liner tube shall be impregnated with resin not more than 5 days prior to the proposed time of installation and stored out of direct sunlight at temperature less than 40 degrees Fahrenheit (4 degrees Celsius). Any line stored longer than 5 days must be certified by the installer prior to placement. The certification must state that the liner and resin are still viable for installation, and that the curing process has not advanced so far to impede inversion or affect the properties of the final installed product. Any liner stored on-site longer than 5 days must be tested for flexural strength (ASTM D790) by the Contractor at no additional cost to the City. Test results must be submitted to the Engineer prior to final payment of the Contract.
 - D. For Heat Cure CIPP systems, the tube shall be vacuum-impregnated with resin (wet-out) under controlled conditions. The volume of resin used shall be sufficient to fill all voids in the tube material at nominal thickness and diameter. The volume shall be adjusted by adding 5% to 10% excess resin volume compared to the volume of the felt to compensate for the change in resin volume due to polymerization and to allow for any migration of resin into the cracks and joints in the original pipe.
- (3) Tube Insertion
- A. The wet out tube shall be positioned in the pipeline using either inversion (ASTM F 1216) or a pull-in method (ASTM F 1743). If pulled into place, a power winch shall be utilized and care shall be exercised not to damage the tube as a result of pull-in friction. The tube shall be pulled-in or inverted through an existing manhole or approved access point and fully extend to the next designated manhole or termination point.
 - B. Inversion (ASTM F1216)
 - 1. Using Hydrostatic Head - The wet-out tube shall be inserted through an existing manhole or other approved access by means of an inversion process and the application of a hydrostatic head sufficient to fully extend it to the next designated manhole or termination point. The tube shall be inserted into the vertical inversion standpipe with the impermeable plastic membrane side out. At the lower end of the inversion standpipe, the tube shall be turned inside out and attached to the standpipe so that a leakproof seal is created. The inversion head shall be adjusted to be of sufficient height to cause the impregnated tube to invert from point of inversion to point of termination and hold the tube tight to the pipe wall, producing dimples at side connections. Care shall be taken during the inversion so as not to over-stress the felt fiber.
 - 2. Using Air Pressure - The wet-out tube shall be inserted through an existing manhole or other approved access by means of an inversion process and the application of air pressure sufficient to fully extend it to the next designated manhole or termination point. The tube shall be connected by an attachment at the upper end of the guide chute so that a leakproof seal is created and with the impermeable plastic membranes side out. As the tube enters the guide chute, the tube shall be turned inside out. The inversion air pressure shall be adjusted to be of sufficient pressure to cause the impregnated tube to invert from point of inversion to point of termination and hold the tube tight to the pipe wall, producing dimples at side connections. Care shall be taken during the inversion so as not to overstress the woven and nonwoven materials.
 - 3. Required Pressures - Before the inversion begins, the tube manufacturer shall provide the minimum pressure required to hold the tube tight against the existing conduit, and the maximum allowable pressure so as not to damage the tube. Once the inversion has started, the pressure shall be maintained between the minimum and maximum pressures until the inversion has been completed.
 - C. Pull-in Method (ASTM F1743)



1. Perforation of Resin-Impregnated Tube—Prior to pulling the resin-impregnated fabric tube in place, the outer impermeable plastic coating may optionally be perforated. When the resin-impregnated fabric tube is perforated, this shall allow resin to be forced through the perforations and out against the existing conduit by the force of the hydrostatic head or air pressure against the inner wall of the calibration hose.
2. The perforation shall be done after fabric tube impregnation with a perforating roller device at the point of manufacture or at the jobsite. Perforations shall be made on both sides of the lay-flat fabric tube covering the full circumference with a spacing no less than 1.5 in. (38.1 mm) apart. Perforating slits shall be a minimum of 0.25 in. (6.4 mm) long.
3. Pulling Resin-Impregnated Tube into Position—The wet-out fabric tube shall be pulled into place using a power winch. The saturated fabric tube shall be pulled through an existing manhole or other approved access to fully extend to the next designated manhole or termination point. Care shall be exercised not to damage the tube as a result of friction during pull-in, especially where curvilinear alignments, multilinear alignments, multiple offsets, protruding services, and other friction-producing host pipe conditions are present. Once the fabric tube is in place, it shall be attached to a vertical standpipe so that the calibration hose can invert into the center of the resin-impregnated fabric tube. The vertical standpipe shall be of sufficient height of water head to hold the fabric tube tight to the existing pipe wall, producing dimples at side connections. A device such as a dynamometer or load cell shall be provided on the winch or cable to monitor the pulling force. Measure the overall elongation of the fabric tube after pull-in completion. The acceptable longitudinal elongation shall not be more than 5% of the overall length measured after the calibration hose has been installed, or exceed the recommended pulling force.

D. Lubricant During Installation

1. The use of a lubricant during installation is recommended to reduce friction during inversion. This lubricant shall be poured into the fluid in the standpipe in order to coat the calibration hose during inversion. When air is used to invert the calibration hose, the lubricant shall be applied directly to the calibration hose. The lubricant used shall be a nontoxic, oil-based product that has no detrimental effects on the tube or boiler and pump system, and will not adversely affect the fluid to be transported.

(4) Curing

- A. For Heat Cure CIPP systems, curing shall be accomplished by utilizing circulating heated water or steam under hydrostatic pressure in accordance with ASTM F 1216 and the manufacturer's recommended cure schedule.

B. Curing Method

1. Circulating Heated Water

- a. After inversion is completed, a suitable heat source and water recirculation equipment are required to circulate heated water throughout the pipe. The equipment shall be capable of delivering hot water throughout the section to uniformly raise the water temperature above the temperature required to effect a cure of the resin. Water temperature in the line during the cure period shall be as recommended by the resin manufacturer.
- b. The heat source shall be fitted with suitable monitors to gage the temperature of the incoming and outgoing water supply. Another such gage shall be placed between the impregnated tube and the pipe invert at the termination to determine the temperatures during cure.

2. Using Steam

- a. After inversion is completed, suitable steam-generating equipment is required to distribute steam throughout the pipe. The equipment shall be capable of delivering steam throughout the section to uniformly raise the temperature within the pipe above the temperature required to effect a cure of the resin. The temperature in the line during the cure period shall be as recommended by the resin manufacturer.



- b. The steam-generating equipment shall be fitted with a suitable monitor to gage the temperature of the outgoing steam. The temperature of the resin being cured shall be monitored by placing gages between the impregnated tube and the existing pipe at both ends to determine the temperature during cure.
 - c. Steam curing systems shall include an elevated steam discharge. The City Inspector shall monitor and record styrene levels at this point for each liner curing. At direction of the Inspector any steam condensate or styrene residue shall be cleaned and disposed at the Contractor's expense.
- C. Initial Cure
1. Initial cure will occur during temperature heat-up and is completed when exposed portions of the new pipe appear to be hard and sound and the remote temperature sensor indicates that the temperature is of a magnitude to realize an exotherm or cure in the resin. After initial cure is reached, the temperature shall be raised to post-cure temperatures recommended by the resin manufacturer. The post-cure temperature shall be held for a period as recommended by the resin manufacturer, during which time the recirculation of the water and cycling of the boiler or distribution and control of steam to maintain the temperature continues. The curing of the CIPP must take into account the existing pipe material, the resin system, and ground conditions (temperature, moisture level, and thermal conductivity of soil).
- D. Required Pressure
1. The estimated maximum and minimum pressure required to hold the flexible tube tight against the existing conduit during the curing process shall be provided by the manufacturer and shall be increased to include consideration of the external ground water, if present. Once the cure has started and dimpling for laterals is completed, the required pressures shall be maintained until the cure has been completed. The pressure shall be maintained within the estimated maximum and minimum pressure during the curing process. If the steam pressure or hydrostatic head drops below the recommended minimum during the cure, the CIPP shall be inspected for lifts or delamination and evaluated for its ability to fully meet the applicable requirements of these specifications and ASTM F 1216.
- E. Cool-Down
1. Using Cool Water After Heated Water Cure—The new pipe shall be cooled to a temperature below 100°F (38°C) before relieving the static head in the inversion standpipe. Cool-down may be accomplished by the introduction of cool water into the inversion standpipe to replace water being drained from a small hole made in the downstream end. Care shall be taken in the release of the static head so that a vacuum will not be developed that could damage the newly installed pipe.
 2. Using Cool Water After Steam Cure— The new pipe shall be cooled to a temperature below 113°F (45°C) before relieving the internal pressure within the section. Cooldown may be accomplished by the introduction of cool water into the section to replace the mixture of air and steam being drained from a small hole made in the downstream end. Care shall be taken in the release of the air pressure so that a vacuum will not be developed that could damage the newly installed pipe.
- (5) Sealing Linear at Access Structures
- A. The Contractor shall provide a watertight seal between the host pipe and liner pipe at the connection to the sewer access structure. End seal materials shall be made from a rubber material designed to be installed in sanitary sewers. The compression bands and hardware shall be of 304 or 316 stainless steel.
 - B. The Contractor shall reconstruct benches and channels in manholes with grout to match new invert elevations.
- (6) Reinstatement of Service Connections
- A. The Contractor shall be responsible for confirming the locations of all service connections prior to installing and curing the CIPP. All service connection shall be reconnected unless otherwise directed by the Engineer. Service connections shall not be out of service for more than 8 hours during the lining process.



- B. The Contractor shall reinstate all service connections to buildings without excavation, utilizing a remote controlled cutting device, monitored by a video TV camera. The Contractor shall certify he/she has a minimum of 2 complete working cutters plus spare key components on the site before each inversion. The operator of the remote controlled cutting device shall have at least 2 years' experience with such equipment.
 - C. Service connections shall be reestablished to a minimum of 95% of the flow capacity. Any service connection opened to greater than 100% of its original diameter shall have a "Top Hat" system installed at the Contractor's Expense. The Top Hat must extend at least 18-inches into lateral and create at least a 3-inch brim molded flat against lined mainline pipe with a Manufacturer approved adhesive to ensure a tight bond against the CIPP.
 - D. Services shall be cut round and edges shall be smooth and brushed.
 - E. Liner shall be sufficiently tight so that there is no annular space between the connection and the liner.
 - F. No additional payment will be made for excavations for the purpose of reopening connections and the Contractor will be responsible for all costs and liability associated with such excavation and restoration work.
- (7) Chemical Grouting of Service Connections
- A. The intent of lateral connection sealing is to test and seal sewer lateral connections using a specialized chemical grout packer. The purpose of this procedure is the elimination of infiltration into sewers that are otherwise structurally sound.
 - B. The Contractor shall proof test each reinstated service connection via an air test or other approved method. Service connections shall be air tested by isolating the area to be tested with the packer and applying positive pressure into the isolated "void" area. A sensing unit shall be used for continuous monitoring of the "void" pressure. This sensing unit shall be located within the "void" area and accurately transmit pressure readout to the control panel. The test procedure shall consist of applying air pressure into each isolated VOID area. To isolate a VOID, the lateral sealing packer shall be positioned straddling the service connection. The operator shall inflate the packer ends to isolate the service connection and insert an inflatable inversion tube. The service connection shall be tested with a gauge pressure of one-half (1/2) psi per foot of depth of sewer or a minimum of four (4) psi, whichever is larger. The VOID pressure shall be observed during this test for a minimum of 10 seconds. If the VOID pressure drop is greater than 1 psi in 10 seconds, the service connection is considered to have failed the air test. If no pressure can be built up, the connection will also have failed the test. Any connection failing the test shall be sealed and retested utilizing the same method and procedures until it does pass the test. The cost of retesting lateral connections shall be considered incidental and included in the cost of sealing sanitary sewer lateral connection.
 - C. Active leaks at reinstated service connections and reinstated connections that do not pass a proof test shall be sealed by chemical grout or other method approved by the Engineer. Seals shall extend from sanitary sewer main into the service connection for a minimum of 18 inches.
- (8) At completion of work, remove rubbish, debris, dirt, equipment, and excess material from site. Clean adjacent surfaces soiled by and during course of work.

630.4 Measurement

- (1) The department will measure each lineal foot (LF) of Sewer Liner successfully furnished and installed. Distance through manholes is NOT included in this length.
- (2) The department will measure each (EA) lateral connection reopened after sewer lining has been cured.



630.5 Payment

The department will pay for the measured quantity at the contract unit price under the following bid item:

ITEM NUMBER	DESCRIPTION	UNIT
630.01-.11	Sewer Liner – CIPP (size)	LF
631	Re-Open Lateral Connections	EACH

630.6 Testing, Acceptance, & Maintenance

- (1) The Contractor shall furnish all samples for product testing to the Project Engineer. The Project Engineer shall take possession of the samples for testing and shall maintain the chain of custody, deliver the samples to an approved laboratory and pay for all material and product testing performed under this contract.
- (2) The samples shall be prepared and physical properties tested in accordance with ASTM F 1216. The flexural properties must meet or exceed the values listed in Section 625.2.5. For each inversion length, the preparation of two CIPP samples is required, one from each of the following two methods:
 - A. The sample shall be cut from a section of cured CIPP at an intermediate manhole or at the termination point that has been inverted through a like diameter pipe which has been held in place by a suitable heat sink, such as sandbags.
 - B. The sample shall be fabricated from material taken from the tube and the resin/catalyst system used and cured in a clamped mold placed in the downtube when circulating heated water is used and, in the silencer, when steam is used.
- (3) Each sample shall be large enough to provide five specimens for flexural testing and tensile testing.
- (4) The following test procedures shall be followed after the sample is cured and removed.
- (5) Short-Term Flexural (Bending) Properties - The initial tangent flexural modulus of elasticity and flexural stress shall be measured for gravity and pressure pipe applications in accordance with Test Methods D 790 and shall meet the requirements of Section 625.2.5.
- (6) Tensile Properties - The tensile strength shall be measured for pressure pipe applications in accordance with Test Method D 638 and must meet the requirements of Section 625.2.5.
- (7) Water Tightness Test - Gravity pipes shall be tested using the APS Water Tightness Standard DWA M143-20. If the representative samples of the liner fail the water tightness test, the Contractor may be requested to submit a manufacturer reviewed/approved repair plan or handled on a case-by-case basis.
- (8) Delamination Test - If required by the owner in the contract documents or purchase order, a delamination test shall be performed on each inversion length specified. The CIPP samples shall be prepared in accordance with Section 625.2.5, except that a portion of the tube material in the sample shall be dry and isolated from the resin in order to separate tube layers for testing. Delamination testing shall be in accordance with Test Method D 903, with the following exceptions:
 - A. The rate of travel of the power-actuated grip shall be 1 in. (25 mm)/min.
 - B. Five test specimens shall be tested for each inversion specified.
 - C. The thickness of the test specimen shall be minimized, but shall be sufficient to adequately test delamination of nonhomogeneous CIPP layers.
 - D. The peel or stripping strength between any nonhomogeneous layers of the CIPP laminate shall be a minimum of 10 lb/in. (178.60 g/mm) of width for typical CIPP applications.
- (9) CIPP Wall Thickness - The method of obtaining CIPP wall thickness measurements shall be determined in a manner consistent with 8.1.2 of Specification D 5813. Thickness measurements shall be made in accordance with Practice D 3567 for samples prepared in accordance with Section 625.4. Make a minimum of eight measurements at evenly spaced intervals around the circumference of the pipe to ensure that minimum and maximum thicknesses have



Engineering Department

400 La Crosse St., La Crosse, WI 54601 • (608) 789-7505 • Fax: (608) 789-8184
<http://www.cityoflacrosse.org>

- been determined. Deduct from the measured values the thickness of any plastic coatings or CIPP layers not included in the structural design of the CIPP.
- (10) The average thickness shall be calculated using all measured values and shall meet or exceed minimum design thickness as agreed upon between purchaser and seller. If the average thickness does not meet or exceed the minimum design thickness but is still determined to be acceptable, the bid item payment may be reduced by the percentage difference in thickness for the subject lining segment. The minimum wall thickness at any point shall not be less than 87.5% of the specified design thickness as agreed upon between purchase and seller.
 - (11) An alternative method for measuring the wall thickness may be performed within the installed CIPP at either end of the pipe by the ultrasonic pulse echo method as described in Practice E 797. A minimum of eight (8) evenly spaced measurements shall be made around the internal circumference of the installed CIPP within the host pipe at a distance of 12 to 18 in. from the end of the pipe. For pipe diameters of fifteen (15) in. or greater, a minimum of sixteen (16) evenly spaced measurements shall be recorded. The ultrasonic method to be used is the flaw detector with A-scan display and direct thickness readout as defined in 6.1.2 of E 797. A calibration block shall be manufactured from the identical materials used in the installed CIPP to calibrate sound velocity through the liner.
 - (12) Calibration of the transducer shall be performed daily in accordance with the equipment manufacturer's recommendations. The average thickness shall be calculated using all measured values and shall meet or exceed minimum design thickness as agreed upon between purchaser and seller. The minimum wall thickness at any point shall not be less than 87.5% of the specified design thickness.
 - (13) CCTV Inspection and Acceptance - The Contractor shall perform a detailed closed-circuit television inspection in accordance with NAASCO's Pipeline Assessment and Certification Program (PACP) standards, after installation of the CIPP liner and reconnection and grouting of the service connections. The camera shall be panned 360 degrees around the circumference of the pipe and along the wall of the finished pipe at 10 foot intervals. The finished liner shall be continuous over the entire length of the installation and shall be free of significant visual defects, damage, deflection, holes, leaks and other defects. Unedited digital documentation of the inspection shall be provided to the Owner within ten (10) working days of the liner installation. The data shall note the inspection date, location of all reconnected service connections, debris, as well as any other defects in the liner, including, but not limited to, gouges, cracks, bumps, or bulges. If post installation inspection documentation is not submitted within ten (10) working days of the liner installation, the City may at its discretion suspend any further installation of CIPP until the post installation documentation is submitted. As a result of this suspension, no additional working days will be added to the contract, nor will any adjustment be made for increase in cost. Immediately prior to conducting the closed circuit television inspection, the Contractor shall thoroughly clean the newly installed liner removing all debris and buildup that may have accumulated.
 - (14) The installation shall be inspected by closed-circuit television No infiltration of groundwater shall be observed. All live service entrances shall be accounted for and be unobstructed. CCTV inspection of the CIPP liner shall be in accordance with ASTM F 1216 and Section 625.3.2.
 - (15) The contractor shall take a still image of the watertight seal between the host pipe and liner at the connection to the sewer access structure.
 - (16) If the Engineer's review of the final CCTV submittal identifies repairable defects, the Contractor may be requested to submit a manufacturer reviewed/approved repair plan rather than reinstalling the entire defective CIPP. Any such repairs shall include an extended warranty by the Contractor for one (1) additional year from the expiration of the Contract warranty.
 - (17) The following repair methods for common defects are considered acceptable:
 - A. Defect: Wrinkles/ridges exceeding 5% of pipe diameter outside of 120-degree invert arc – OR – wrinkles/ridges exceeding 2% of pipe diameter inside of the 120-degree invert arc.



Engineering Department

400 La Crosse St., La Crosse, WI 54601 • (608) 789-7505 • Fax: (608) 789-8184
<http://www.cityoflacrosse.org>

1. Repair: Grind to within required tolerance, coat ground area with manufacturer's approved resin. Point repair may be required if minimum thickness is affected by repair.
 2. Rejection Criteria: The Engineer may reject the work if wrinkles or ridges exceed 10% of pipe diameter.
 - B. Defect: Holes, tears, soft spots, lifts, delamination, blisters/bubbles.
 1. Repair: Point repairs under manufacturer's approved recommendations.
 2. Rejection Criteria: If defective areas cover greater than 5% of the surface area the Engineer reserves the right to reject the work.
 - C. Defect: CIPP thickness less than calculated minimum thickness.
 1. Repair: If the Engineer determines that the CIPP is acceptable, payment may be reduced by the percentage below the design minimum thickness. In some cases, a second CIPP within the first may be allowed.
 2. Rejection Criteria: If the actual thickness is less than 87.5% of the design minimum thickness, the Engineer reserves the right to reject the work.
 - D. Defect: Service reinstated to greater than 100% of original flow capacity.
 1. Repair: A "Top Hat" system must be installed at the Contractor's Expense. The Top Hat must extend at least 18-inches into lateral and create at least a 3-inch brim molded flat against lined mainline pipe with a Manufacturer approved adhesive to ensure a tight bond against the CIPP.
 2. Rejection Criteria: The Engineer reserves the right to reject any improperly installed Top Hat repairs.
- (18) Additional defects may be identified, and will be handled on a case-by-case basis.



635-REHABILITATE MANHOLE

635.1 General Description

- (1) This section describes materials, equipment, and appliances necessary for sewer manhole rehabilitation. The materials furnished and installed shall conform to the requirements specified herein for the type and size of material named in the plan.
- (2) Items of work associated shall include, but not limited to, the following:
 - A. Mobilization, site preparation, and applicable permits.
 - B. Photo documentation of sanitary sewer manhole to determine installed conditions.
 - C. Cleaning of existing sanitary sewer manholes to condition necessary for proper installation of product.
 - D. Repair and filling of voids
 - E. Elimination of active infiltration prior to making the application.
 - F. The spray application of a cementitious mix to a structural monolithic cementitious liner.
 - G. Flow control, including bypass pumping, if required.
 - H. Post-rehabilitation photo documentation
 - I. Cleanup.
 - J. Other appurtenant and incidental work.

635.1.1 Referenced Documents

- (1) This specification references ASTM standards, National Association of Corrosion Engineers (NACE), the Society for Protective Coatings (SSPC), and other related standards, which are made a part hereof by reference and shall be the latest edition thereof.

ASTM Standard D638	Standard Test Method for Tensile Properties of Plastics.
ASTM Standard D790	Standard Test Methods for Flexural Properties of Unreinforced and Reinforced Plastics and Electrical Insulating Materials.
ASTM Standard D695	Standard Test Method for Compressive Properties of Rigid Plastics.
ASTM Standard D4541	Standard Test Method for Pull-off Strength of Coatings Using a Portable Adhesion Tester.
ASTM Standard D2584	Standard Test Method for Ignition Loss of Cured Reinforced Resins
ASTM Standard D2240	Standard Test Method for Rubber Property - Durometer Hardness.
ASTM Standard D543	Standard Practices for Evaluating the Resistance of Plastics to Chemical Reagents.
ASTM Standard C109	Standard test Method for Compressive Strength Hydraulic Cement Mortars.
ASTM Standard C579	Compressive Strength of Chemically Setting Silicate and Silica Chemical Resistant Mortars.
ASTM Standard D4258	Standard Practice for Surface Cleaning Concrete for Coating
ASTM Standard D4259	Standard Practice for Preparation of Concrete by Abrasion Prior to Coating Application
ASTM Standard D4263	Standard Test Method for Indicating Moisture in Concrete by the Plastic Sheet Method
ASTM Standard F1869	Standard Test Method for Measuring Moisture Vapor Emission Rate of Concrete Subfloor using Anhydrous Calcium Chloride
ASTM Standard F2170	Standard Test Method for Determining Relative Humidity in Concrete floor slabs using in situ Probes
ASTM Standard C 495	Standard test method for Compressive Strength of Lightweight insulating concrete
SSPC-SP 13/NACE No. 6	Surface Preparation of Concrete
NACE Standard SP0892-2007-SG	Coatings and Linings over Concrete for Chemical Immersion and Containment Service



IRCI Guideline No. 310.2-1997 Selecting and Specifying Concrete Surface Preparation for Sealers, Coatings, and Polymer Overlays

635.1.2 Submittals

- (1) The Contractor shall not install materials or equipment, which requires submittals, until reviewed by the Engineer. The Engineer's review will be completed as quickly as possible, but may require up to ten (10) working days from the date the submittals are received until they are sent to the Contractor.
- (2) The Contractor shall submit the following materials to the Engineer:
 - A. Product Data.
 1. Manufacturer's product literature and application, installation and recommended repair (patching) requirements for materials used in liner.
 2. Manufacturer's product certification of conformance to ASTM Standards for materials used in liner.
 3. Material Safety Data Sheets (MSDS) for each product used.
 4. Documentation that the proposed manhole rehabilitation process has a three year history for reconstruction of sewer manholes on projects of similar size and scope.
 5. Manhole liner thickness design
 6. Compensation for all work required for the submittal of product data shall be considered incidental to the project.
 - B. Digital Photo.
 1. Submit digital photo documentation in cleaned pre-lining condition.
 2. Submit digital photo documentation in post-lining condition.
 - C. Sewage Bypassing Plan.
 1. Submit proposed plan for bypassing sanitary sewage during liner installation. Plan shall be to scale and shall show location of existing City sewer access structures.
 - D. Traffic Control Plan.
 1. Submit proposed plan for Traffic Control during liner installation. Plan shall be to scale, shall show location of existing City sewer access structures, and be in accordance to the Contract document requirements.
 - E. Public Notifications.
 1. Submit proposed public notification letter and door hangers. Notifications shall be in accordance to Section 630.1.3.E Public Notification.

635.1.3 Requirements of Contractor

- (1) Experience
 - A. Each installer must satisfy all insurance, financial, and bonding requirements of the City, and have at least three years active experience in the installation of the product. In addition, the applicator must have successfully installed at least 500 vertical feet of the product in wastewater collection systems.
 - B. Each Applicator must provide manufacturer certification that the applicator has been trained and approved in the handling, mixing, and application of the products to be used.
 - C. Equipment used for applying the products shall have certification that the equipment has been manufactured or approved by the protective coating manufacturer and applicator personnel have been trained and certified for proper use of the equipment.
 - D. The site superintendent in direct responsible charge of the manhole rehabilitation installation shall have extensive experience in the installation of. Information documenting who the site superintendent will be and their experience in installation shall be submitted to the City. The City's decision regarding the qualification of the site superintendent shall be final. If the initial site superintendent does not meet the experience criteria, the Contractor shall submit a more qualified individual or otherwise satisfy the City regarding the installation supervision and quality control.



Engineering Department

400 La Crosse St., La Crosse, WI 54601 • (608) 789-7505 • Fax: (608) 789-8184
<http://www.cityoflacrosse.org>

(2) Safety.

- A. The Contractor agrees to perform all work under this contract in accordance with local, state and federal safety regulations. This includes, but is not limited to, evaluation of the atmosphere to determine the presence of toxic or flammable vapors or lack of oxygen prior to entering access areas such as sewer access structures and performing inspection or cleaning operations and the use of confined entry equipment for all entries.
- B. Applicator shall initiate and enforce quality control procedures consistent with applicable ASTM, NACE, and SSPC standards and the protective coating manufacturer's recommendations.

(3) Bypassing Pumping.

- A. The Contractor shall follow directions in the City of La Crosse Standard Procedures By-Pass Pumping.
- B. Provide for flow of sewage around sections of pipe to be lined.
- C. One stretch of pipe at a time (manhole to manhole) shall be installed unless otherwise approved by the Engineer.
- D. It shall be the responsibility of the Contractor to notify individuals and businesses whose sanitary sewer will be interrupted during pipe lining operations. It shall be the responsibility of the Contractor to provide necessary service to businesses affected by the lining operation.

(4) Water for Cleaning.

- A. The Contractor shall furnish water for cleaning and flushing the existing sewer pipe and for inversion and installation of the CIPP. Contractor shall obtain water from the City Water Utility. All hydrant use must be pre-approved by the City Water Utility. Contractor shall obtain a permit from the City Water Utility and shall properly utilize back-flow prevention and/or other hydrant access device supplied by and installed onto hydrant by the City Water Utility. The Contractor shall pay all costs associated with coordinating and obtaining water for the cleaning, flushing and inversion operations, including the cost of any cold-weather insulation required at the hydrant access device.

(5) Disposing of Debris.

- A. Contractor shall be responsible for disposing of debris removed from sewers at a licensed disposal facility. The Contractor shall pay all costs associated with the transport and disposal of such debris.

(6) Public Notification.

- A. Contractor shall make every effort to maintain service usage throughout the duration of the project. In the event that a service needs to be taken out of service, the maximum amount of time allowed for the service interruption shall be 8 hours for any property served by the sewer. The Contractor shall implement a public notification program that shall, at a minimum, require the Contractor to be responsible for contacting all tenants and owner of each home or business connected to the sanitary sewer and informing them of the work to be conducted and the date, time and length of service interruption.
- B. The Contractor shall prepare and submit written notice describing the work to be performed for the Engineer to review. Upon acceptance by the Engineer, the notice shall be delivered to each home or business a minimum of seven (7) days prior to the beginning of work being conducted on the pipe section. Door hangers shall also be placed at effected properties between no later than 24 hours and no earlier than 72 hours prior to the sewer service interruption. All notices shall also contain a local (or toll free) telephone number of the Contractor that property owners can use to discuss the project or any problems that arise during installation of the liner. Contractor shall also arrange meetings with any occupants whose service cannot be reinstated within the time referenced in the written notice. Any related costs such as hotel expenses or residential bypass pumping are the responsibility of the Contractor.
- C. The City shall provide the Contractor with names and addresses of effected property owners and tenants within the project limits.



635.2 Materials

- (1) The materials are to be kept dry, protected from weather and stored under cover. Protective coating materials are to be handled according to their material safety data sheets.

635.2.1 Patching Material

- (1) A quick-setting cementitious material for patching and filling voids and cracks shall have the following minimum requirements.

Property	Test Method	Minimum Result
Compressive Strength	ASTM C-109	6hr-1,400 psi
Bond	ASTM C-321	28day – 150psi
Shrinkage	ASTM C-596	0% at 90% Relative Humidity

635.2.2 Infiltration Control Material

- (1) A rapid setting cementitious product specifically formulated for infiltration control. Material shall have the following minimum requirements.

Property	Test Method	Minimum Result
Compressive Strength	ASTM C-109	1hr – 600 psi
		24hr – 1,000 psi
Bond	ASTM C-321	1hr – 30 psi
		24hr – 80 psi

635.2.3 Repair Liner Material

- (1) Repair materials shall be used to fill voids, structurally reinforce and/or rebuild surfaces, etc. as determined necessary by the Engineer and protective coating applicator. Repair materials must be compatible with the specified epoxy coating and shall be applied in accordance with the manufacturer’s recommendations.
- (2) An ultra high strength, high build, corrosion resistant cement with the following minimum requirements.

Property	Test Method	Minimum Result
Compressive Strength	ASTM C-109	1 day – 3,000 psi
		28 day – 9,000 psi
Flexural Strength	ASTM C-293	1 day – 650 psi
		28 day – 800 psi
Shrinkage	ASTM C-157	0% at 90% Relative Humidity

- (3) The material should meet or exceed industry standards and shall not have any basic ingredient that exceeds EPA maximum allowable limits for any heavy metal.
- (4) The following products may be accepted and approved as compatible repair basecoat materials for epoxy topcoating for use within the specifications:
- A. 100% solids, solvent-free epoxy grout specifically formulated for epoxy topcoating compatibility. The epoxy grout manufacturer shall provide instructions for trowel or spray application and for epoxy topcoating procedures.
 - B. Factory blended, rapid setting, high early strength, fiber reinforced, non-shrink repair mortar that can be trowelled or pneumatically spray applied may be approved if specifically formulated to be suitable for epoxy topcoating. Such repair mortars should not be used unless their manufacturer provides information as to its suitability for topcoating with an epoxy coating. Project specific submittals should be provided including application, cure time and surface preparation procedures which permit optimum bond strength with the epoxy coating.



635.2.4 Protective Coating Material

- (1) Epoxy coating system – 100% solids, solvent-free two-component epoxy resin system thixotropic in nature and filled with select fillers to minimize permeability and provide sag resistance acceptable to these specifications (up to 125 mils in a single coat).
 - A. Solids Content (% vol) 100
 - B. Mix Ratio 3:1
 - C. Compressive Strength 18,000 psi
 - D. Tensile Strength 7,600 psi
 - E. Tensile Elongation, % 1.5%
 - F. Bond Strength – Concrete > Tensile Strength of Concrete
- (2) Manufacturer approved heated plural component spray equipment shall be used in the application of the specified protective coating.

635.3 Construction Methods

- (1) All steps shall be reviewed and tested prior to the next step being performed.

635.3.1 Pre-Work Procedures

- (1) Prior to starting work, the Contractor shall measure all manholes to verify dimensions.
- (2) All by-pass pumping equipment shall be in place and operating and shall follow City of La Crosse Standard Procedures.
- (3) Place covers over sewer inverts to prevent extraneous material from entering the sewer lines.
- (4) Temperature of the surface to be coated should be maintained between 40 deg F and 120 deg F during application. Prior to and during application, care should be taken to avoid exposure of direct sunlight or other intense heat source to the structure being coated. Where varying surface temperatures do exist, care should be taken to apply the coating when the temperature is falling versus rising.

635.3.2 Surface Preparation

- (1) Applicator shall inspect all surfaces specified to receive a protective coating prior to surface preparation. Applicator shall notify Owner of any noticeable disparity in the surfaces which may interfere with the proper preparation or application of the repair mortar and protective coating.
- (2) All contaminants including: oils, grease, incompatible existing coatings, waxes, form release, curing compounds, efflorescence, sealers, salts, or other contaminants shall be removed from the pipe invert, bench and barrel section.
- (3) Any concrete or mortar that is not sound or has been damaged by chemical exposure shall be removed to a sound concrete surface or replaced.
- (4) Surface preparation method(s) should be based upon the conditions of the substrate, service environment and the requirements of the epoxy protective coating to be applied.
- (5) Surfaces to receive protective coating shall be cleaned and abraded to produce a sound surface with adequate profile and porosity to provide a strong bond between the protective coating and the substrate. Generally, this can be achieved with a low pressure water cleaning using equipment capable of 5,000 psi at 4 gpm. Other methods such as high pressure water jetting (refer to NACE Standard No. 5/SSPC-SP12), abrasive blasting, shotblasting, grinding, scarifying or acid etching may also be used. Detergent water cleaning and hot water blasting may be necessary to remove oils, grease or other hydrocarbon residues from the concrete. Whichever method(s) are used, they shall be performed in a manner that provides a uniform, sound clean neutralized surface that is not excessively damaged.
- (6) Infiltration shall be stopped by using a material which is compatible with the specified repair mortar and is suitable for topcoating with the specified epoxy protective coating.



- (7) Test prepared surfaces after cleaning but prior to application of the epoxy coating to determine if a specific pH or moisture content of the concrete is required according to manufacturer's recommendations.
- (8) Digitally photo document the cleaned manhole condition prior to any patching. The pre-rehabilitation and post rehabilitation photos shall be provided prior to final payment.
- (9) Areas of manholes that are structurally damaged and in need of repair beyond the scope of this specification shall be brought to the attention of the Engineer.
- (10) Any areas in need of reconstruction shall be done prior to lining.

635.3.3 Application of Repair/Liner Materials

- (1) Areas where structural steel has been exposed or removed shall be repaired in accordance with the Project Engineer's recommendations.
- (2) Repair materials shall meet the specifications herein. The materials shall be trowel or spray applied utilizing proper equipment on to specified surfaces. The material thickness shall be a minimum thickness of one-half inch.
- (3) After the interior walls have been completed, the covers over the inverts shall be removed and the bench sprayed in such a manner that a gradual slope is produced from the wall to the invert with the thickness at the invert to be not less than one-half inch.
- (4) No application shall be made if ambient temperature is below 40 degrees Fahrenheit. No application shall be made to frozen surfaces or if freezing is expected to occur within the substrate within twenty four (24) hours after application.
- (5) The Contractor shall not spray the structure until all work designated around it (CIPP, reconstruction, re-laid sewer pipe, etc.) is completed.
- (6) If using approved cementitious repair materials, such shall be trowelled to provide a smooth surface with an average profile equivalent to coarse sandpaper to optimally receive the protective coating. No bugholes or honeycomb surfaces should remain after the final trowel procedure of the repair mortar.
- (7) The repair materials shall be permitted to cure according to manufacturer recommendations. Curing compounds should not be used unless approved for compatibility with the specified protective coating.
- (8) After abrasive blast and leak repair is performed, all surfaces shall be inspected for remaining laitance prior to protective coating application. Any evidence of remaining contamination or laitance shall be removed by additional abrasive blast, shotblast or other approved method. If repair materials are used, refer to these specifications for surface preparation. Areas to be coated must also be prepared in accordance with these specifications after receiving a cementitious repair mortar and prior to application of the epoxy coating.
- (9) The Contractor shall gently score around the bottom of the casting and adjustment rings to aid in creating a break point for future adjustment.
- (10) Digitally photo document the rehabilitated structure.

635.3.4 Application of Protective Coating

- (1) Application procedures shall conform to the recommendations of the protective coating manufacturer, including material handling, mixing, environmental controls during application, safety, and spray equipment.
- (2) The spray equipment shall be specifically designed to accurately ratio and apply the specified protective coating materials and shall be regularly maintained and in proper working order.
- (3) The protective coating material shall be seamless from the pipe invert to the casting. The coating shall be spray applied by a Certified Applicator of the protective coating manufacturer.
- (4) Specified surfaces shall be coated by spray application of a moisture tolerant, solvent-free, 100% solids, epoxy protective coating as further described herein. Spray application shall be to a minimum wet film thickness of 100 mils.



Engineering Department

400 La Crosse St., La Crosse, WI 54601 • (608) 789-7505 • Fax: (608) 789-8184
<http://www.cityoflacrosse.org>

- (5) If necessary, subsequent topcoating or additional coats of the protective coating should occur as soon as the basecoat becomes tack free, ideally within 12 hours but no later than the recoat window for the specified products. Additional surface preparation procedures will be required if this recoat window is exceeded.

635.4 Measurement

- (1) The department will measure each (EA) Sanitary Manhole that has been successfully rehabilitated.

635.5 Payment

The department will pay for the measured quantity at the contract unit price under the following bid item:

ITEM NUMBER	DESCRIPTION	UNIT
635.01-.07	Rehabilitate Sanitary Manhole (Depth)	EACH

635.6 Testing, Acceptance, & Maintenance

- (1) During application a wet film thickness gage, meeting ASTM D4414 - Standard Practice for Measurement of Wet Film Thickness of Organic Coatings by Notched Gages, shall be used to ensure a monolithic coating and uniform thickness during application.
- (2) The City may randomly request up to four-two inch cubes be cast each day in accordance with ASTM C-140 for compressive strength testing. The cost of testing shall be incidental to the Contract.
- (3) After the protective coating has set hard to the touch it shall be inspected with high-voltage holiday detection equipment. Surface shall first be dried; an induced holiday shall then be made on to the coated concrete surface and shall serve to determine the minimum/maximum voltage to be used to test the coating for holidays at that particular area. The spark tester shall be initially set at 100 volts per 1 mil (25 microns) of film thickness applied but may be adjusted as necessary to detect the induced holiday (refer to NACE RPO188-99). All detected holidays shall be marked and repaired by abrading the coating surface with grit disk paper or other hand tooling method. After abrading and cleaning, additional protective coating material can be hand applied to the repair area.
- (4) All touch-up/repair procedures shall follow the protective coating manufacturer's recommendations.
- (5) A final visual inspection shall be made by the Inspector and manufacturer's representative. Any deficiencies in the finished coating shall be marked and repaired according to the procedures set forth herein by Applicator.
- (6) The municipal sewer system may be put back into non-severe operational service as soon as the final inspection has taken place. However, for severe corrosion duty such as high concentrations of acids, bases or solvents, 3 to 7 days and/or force cure by heat induction to the coated surfaces may be necessary prior to returning to service. Consult coating manufacturer for further details.



640-BY-PASS PUMPING

640.1 General Description

- (1) Work in this section shall consist of By-Pass pumping required for placing of CIPP liner or manhole rehabilitation. By-pass pumping may be included for other sanitary sewer replacement and repair.

640.2 Materials

- (1) The methods and equipment shall be subject to approval by the Engineer. The pump and by-pass lines shall be of adequate capacity and size to handle the flow.

640.3 Construction Methods

- (1) Contractor shall familiarize himself with the City’s sanitary sewerage facilities and develop an adequate bypassing plan. A written plan shall be submitted to the Engineer for approval prior to the start of work. The methods, equipment, type of hose, etc., shall be subject to approval by the Engineer.
- (2) Bypass pumping shall be limited to the regular hours of work as provided by the City unless necessitated by an emergency beyond the Contractor’s control. A representative of the Contractor must be on-site at all times that bypass pumping is in operation.
- (3) A Limited Exemption for Construction Noise permit shall be required by the contractor.
- (4) The Contractor shall provide for the continuous flow of sewage around the sections of sewer line designated for replacement or lining. A bypass shall be installed by plugging the line at an existing upstream sewer access structure and pumping or directing the flow to a downstream sewer access structure. The pump(s) and bypass lines shall be of adequate capacity and size to handle the flow. Raw sewage shall be routed back to the sanitary sewerage system or hauled and disposed of as approved by the City.
- (5) Hoses crossing streets, driveways, parking areas, etc., are to be ramped over to prevent damage to the hoses.
- (6) No spillage of wastewater to adjacent streets, lawns, etc., shall be tolerated. If any such spillage should occur, all construction operations shall cease and cleanup shall commence immediately and be completed to the satisfaction of the Engineer prior to the resumption of any construction operations.

640.4 Measurement

- (1) The department will measure By-Pass pumping as a lump sum (LS) for the entire project.

640.5 Payment

The department will pay for the measured quantity at the contract unit price under the following bid item:

ITEM NUMBER	DESCRIPTION	UNIT
640	By-Pass Pumping	LS

640.6 Testing, Acceptance, & Maintenance

N/A



8. STREETSAPING / LIGHTING

- 800 GENERAL LIGHTING CONSTRUCTION
- 805 EXCAVATION AND BACKFILL
- 810 LIGHTING BASES
- 815 LIGHTING CONDUIT
- 820 PULL BOXES
- 825 LIGHTING WIRING
- 830 POLES, ARMS, STANDARDS
- 835 LIGHTING CONTROL CABINET
- 850 BRICK PAVERS
- 860 CONCRETE EDGING
- 860 MULCH
- 870 INSTALL V-LOC SIGN SUPPORT
- 875 INSTALL NEW VALVE BOX TOP
- 880 SAW CUT V-SHAPE TOOL JOINT



8. STREETSCAPING / LIGHTING

800-GENERAL LIGHTING CONSTRUCTION

800.1 General Description

- (1) Perform work in accordance with the provisions of WisDOT Standard Specifications for Highway and Structure Construction except as hereinafter modified.
- (2) Street lighting construction shall consist of excavating the required trenches and tunnels; furnishing and laying therein the required conduit; placing wire; installing the required structures and appurtenances; backfilling the trenches; restoring the site of the work; and completing the work to the required lines and grades. All work shall be performed as shown on the plans and in accordance with the contract.
- (3) The following requirements must be fulfilled before approval is given to commence work:
 - A. Contract forms to be completely executed.
 - B. Notice to utilities given.
 - C. Clearance from Engineer regarding disposal of surplus material, detouring of traffic, closing of streets and alleys, city facilities and services, shall be obtained by the Contractor.

800.2 Equipment & Materials

- (1) Equipment and tools necessary for performing all parts of the lighting work shall be satisfactory as to design, capacity, and mechanical condition for the purposes intended, and any equipment which is not maintained in full working order, or which as used by the Contractor is inadequate to obtain the results prescribed, shall be repaired, improved, replaced, or supplemented to obtain the progress and workmanship contemplated by the contract.
- (2) The Concrete used in the construction and installation of lighting bases and lighting cabinet bases shall conform to the requirements for General Concrete as specified in the City of La Crosse Standard Procedures.
- (3) All Concrete, Bituminous, and gravel pavements, sidewalks, curbs and gutters, fences, boulevard restoration, or other structures which may have been damaged or displaced by the Contractor in constructing the traffic signal shall be rebuilt or re-laid properly to the original line and grade in accordance with City of La Crosse Standard Procedures.
- (4) All electrical materials and their installation shall conform with the latest requirements of the National Electrical Code (NEC), Wisconsin Electrical Code and accepted standards of good workmanship. All materials for which a standard has been established by the Underwriters Laboratories, Inc. shall have their label firmly attached.
- (5) All materials which are to be furnished by the City shall be picked up by the Contractor at the Municipal Storage Unit, unless otherwise specified. Contractor shall schedule a pick-up time 5 business days in advance of material pick up. All costs of the work included in this Section shall be at the expense of the Contractor unless otherwise provided. The Contractor shall provide equipment and labor to load materials onto Contractor's vehicle or trailer. Complete quantities of an item shall be picked up on one appointment unless the City agrees to a partial quantity disbursement.

800.3 Construction Methods

- (1) Removal of all Concrete, asphalt, trees, brush, sidewalk, or other surface materials shall be done in compliance with the City of La Crosse Standard Procedures.
- (2) The Contractor shall not, unless the proper parties have given written consent, enter or occupy with men, tools or materials any land adjoining the work.
- (3) The Contractor shall safeguard engineering stakes; and resetting, made necessary through carelessness of workmen, shall be done by the City at the Contractor's expense.



Engineering Department

400 La Crosse St., La Crosse, WI 54601 • (608) 789-7505 • Fax: (608) 789-8184
<http://www.cityoflacrosse.org>

- (4) No cement work shall be done during freezing weather unless the Contractor shall provide the necessary means for, and shall heat the gravel, sand and water, and shall comply with all requirements to thoroughly protect the concrete from frost during curing; all at the cost and expense of the Contractor and with the approval of the Engineer.
- (5) The City Inspector shall be notified at least forty-eight (48) hours in advance of beginning any underground electrical construction work, such as installing cable-in-duct, PVC conduit and concrete bases, and shall be updated frequently as to stopping and restarting underground work. All underground conduit, cable, or concrete base forms shall be inspected by the City Inspector before any trench is backfilled or concrete is poured. Any work completed without such inspection is subject to rejection as unacceptable work and shall be immediately removed and acceptably replaced or otherwise satisfactorily corrected by and at the expense of the Contractor.
- (6) The existing signal and lighting poles, conduits, handholes, and manholes not scheduled for removal or abandonment shall be protected during construction. If the contractor believes that damage to such facilities is unavoidable, the contractor shall not damage or remove any facilities until the City Traffic Engineering electrical inspector has reviewed and approved such actions. Any damage or removal of City electrical conduit, wire, fiber, or structures, without the specific approval by the City Traffic Engineering electrical inspector shall be promptly repaired or replaced by and at the expense of the contractor. The City may elect to do repair work with City crews. The cost for any repair work done by the City will be billed to the contractor.
- (7) Any damage or removal of City street lighting, traffic signal, or communication facilities shall be repaired or replaced within 24 hours, but any resulting street light outage resulting from such damage or removal shall be confined to as few numbers of street lights as possible. The streetlight circuits shall remain operational each and every night. The City reserves the right to make temporary or permanent repairs at any time after the damage or removal, even within 24 hours of the damage or removal, with the full cost of such work, including engineering time, billed to the general contractor.
- (8) Unless a manhole (utility access structure), handhole, or structure is specifically designated for removal, it shall be saved. The contractor shall consult with the engineer or inspector before removing or damaging any existing facilities.

800.3.1 Dewatering

- (1) The Contractor shall keep all excavations free of water during and until completion of the work, as directed by the Project Engineer. The Contractor shall be responsible for the continuous control of water at all times during the course of construction, and shall provide adequate backup systems to accomplish control of water entering excavations, trenches, and other parts of the work and shall keep said excavations dry until the structures or utilities to be built therein are completed.
- (2) No concrete shall be installed in water nor shall water be allowed to rise over concrete at least twenty-four (24) hours after the concrete has been placed. Water shall be controlled during periods when concrete is being placed and as such other times as is necessary for efficient and safe execution of the work.
- (3) The Contractor shall protect all local water supplies from harm as a result of dewatering operations, and provide remedial measures for any situations where such harm occurs.
- (4) All water removed from the construction site shall be discharged through pipes or hoses. The conveying of water in open ditches or trenches will not be allowed. Water shall be discharged in a manner that will not cause soil erosion at the discharge point. Discharge shall not cause siltation or flooding in any stream, storm sewer, or on adjacent properties.
- (5) All costs for making all extra excavations necessary to prevent the water from interfering with the proper construction of the work, bailing, pumping, and dewatering shall be borne by the Contractor, and included in the prices bid for other items of work. All required pumping, drainage, and disposal of groundwater shall be done without damage to adjacent property or structures, or to the operations of other Contractors and without



interference with the access rights of public or private parties. The Contractor shall modify the water control system at their own expense if, after installation and while in operation, it causes or threatens to cause damage to adjacent property or to existing buildings, structures, or utilities.

800.3.2 Other Utilities

- (1) The location of pipes and other underground objects are approximately correct as shown on the plans, but should they be found to be otherwise, the Contractor shall have no claim on that account, it being understood that the Engineer does not warrant the plot of underground objects to be correct.
- (2) The Contractor shall notify all utilities, both public and private, including gas, electric, garbage collection, telephone, sewer and water, of his schedule of operations. The notice shall be given at least 48 hours prior to actual date of the commencing of construction. The Contractor shall also check as to any utility facilities which may be encountered during construction and take due notice of it.
- (3) The same notice and determination of facilities which may be encountered as well as to proposed blocking of streets or alleys shall be given to the Fire and Police Departments so as to enable them to maintain and plan their operations.
- (4) The Contractor shall give special attention to safeguarding and protecting all utilities, public and private, and shall be held liable for any damage thereto encountered during construction of the entire project.
- (5) Access to all hydrants and valves must be provided at all times because of emergency requirements of Water and Fire Departments.

800.3.3 Trees

- (1) The Contractor shall be responsible for trees damaged during the course of construction, as well as required trimming as directed by Engineering Department.

800.3.4 Personnel Requirements

- (1) Perform electrical work using a journey worker electrician or an electrical apprentice under the onsite supervision of a journey worker electrician. Before performing electrical work, provide the documentation specified below to the engineer proving that the electricians performing the work have attained status as journey worker and apprentice electricians.
- (2) Provide a completion certificate from a state apprenticeship program or a card issued by the Wisconsin department of safety and professional services to prove electricians are qualified.

800.3.5 Traffic Control

- (1) Contractor shall provide a detailed traffic control plan 10 business days prior to starting work to the engineering department for approval from the Traffic Engineer.

800.3.6 Finishing Work

- (1) The Contractor shall maintain all trenches and other excavations, keeping them well filled and in a safe condition for travel, and shall deliver to the City, at the time of acceptance, a finished job with all trenches in a condition satisfactory to the Engineer.
- (2) All concrete, asphalt, and gravel pavements; stone flagging or paving; sidewalks; curbs and gutters; culverts; fences; or other structures which may have been damaged or displaced by the Contractor shall be relaid properly to the original line and grade. In areas with established and tended sod, the Contractor shall sod areas disturbed by the construction; all other areas disturbed by the construction shall be seeded. All of the above work shall be in accordance with these Specifications, or in absence of applicable specifications, to restore the original condition of the structure or area.
- (3) The Contractor shall restore and maintain all asphalt and gravel surfaces in first class condition until final acceptance of the project by the Common Council. All structures and conduit shall be cleaned of any accumulations of silt, debris or other foreign matter. Conduit shall be cleaned by use of the proper size mandrel. The area along the entire installation shall be left clean and graded in a condition satisfactory to the Engineer.



- (4) Unless otherwise provided, all costs of the work included in this Section shall be at the expense of the Contractor, and shall be included in the unit price bid for the contract items with which such work is associated. Final payment will be withheld until such work is done in a manner satisfactory to the Engineer.

800.4 Testing, Acceptance, & Maintenance

- (1) After installation and before final hookup, disconnect loads whether buried or not, and test grounded conductors, equipment grounding conductors, ungrounded conductors, and shielding contained in the cable with a megger. Submit the megger test results to the engineer. Ensure that the megger reads greater than 500 mega ohms during each of the following tests:
 - A. To ground.
 - B. Between each conductor.
 - C. Between each shield.
- (2) The Contractor shall furnish all equipment and appliances necessary to test all installed cable systems. The Contractor shall test and demonstrate to the satisfaction of the Engineer that the lighting circuits are properly connected and operational; continuous and free from short circuits and unspecified grounds; that they are connected in accordance with the wiring layout; and that with fuses removed the resistance to ground of nongrounded circuits between any two adjacent terminals is not less than five (5) megohms.
- (3) All cable shall be "Meggered" and the results recorded. All values shall be in accordance with standard practice for the lengths and type of cable used. All electrical circuits and equipment shall be tested and remain in operating condition.

800.4.1 Underground Inspection

- (1) Contractor shall inform the City when underground items are ready for inspection. The City Inspector or Engineer shall review all underground installations three (3) business days after inspection request from the contractor.
- (2) Contractor may inspect underground installations with the Inspector or Engineer.
- (3) Inspector shall use "Underground Inspection Form" and shall submit form to Contractor for correction or replacement. Underground items shall be corrected or replaced prior to pulling cable or installing above ground equipment.

800.4.2 Aboveground Inspection

- (1) Contractor shall inform the City when aboveground items are ready for inspection. The City Inspector or Engineer shall review all aboveground installations three (3) business days after inspection request from the contractor.
- (2) Contractor may inspect aboveground installations with the Inspector or Engineer.
- (3) Inspector shall use "Aboveground Inspection Form" and shall submit form to Contractor for correction or replacement. Aboveground items shall be corrected or replaced prior to scheduling signal turn on date.

800.4.3 Maintenance

- (1) Operate the completed lighting installation for 20 consecutive nights without failure. Each component that fails shall be repaired or replaced and that component shall again be subject to the twenty-night proper working order test. The lighting system is not complete until electrical work is complete and inspected by the engineer, and electrical systems work properly.



805-EXCAVATION AND BACKFILL

805.1 General Description

- (1) Work in this section shall consist of excavations, preparation, and backfilling required for installation of or removal of traffic signal equipment.

805.2 Materials

805.2.1 Backfill Material

- (1) Backfill material shall conform to WisDOT Standard Specifications for Highway and Structure Construction. The use of reclaimed asphalt, reprocessed material, or blended material shall not be allowed.
- (2) Backfill material shall conform to WisDOT 1 ¼" dense graded base gradation. Excavated material may be used as backfill if it is suitable material in the judgement of the Engineer, is free from debris and organic material, and meets the gradation requirements.

805.3 Construction Methods

- (1) All excavations, auger, or backfilling material shall be incidental to the conduit or lighting base.

805.3.1 Excavation

- (1) The excavations must either be sloped or supported as required to comply with OSHA Excavation standards as defined in 29 C.F.R. Part 1926, Subpart P.
- (2) The bottom of the trench is, in general, to be excavated to the exact form and size of the lower portion of the conduit or base which is to be laid in it.
- (3) Where salvageable material such as crushed rock or stone, of a depth of 6" or more, is encountered in excavation for installation, such material shall be carefully removed and segregated for future use by the City or as directed on the project by the Engineer. In such cases, the Engineer shall order removal and segregation of materials considered salvageable, where it shall be stored, and whether or not it is to be used by the Contractor in final backfilling operations on the project involved. Contractor shall be compensated for hauling of salvaged material on the same basis as for excess dirt or debris.
- (4) All materials shall be so placed as not to endanger the work, and so free access may be had at any time to all parts of the trench and all hydrants and gate valves in the vicinity. They shall be kept neatly piled so as to inconvenience as little as possible the public travel or the adjoining tenants. Reasonable provision shall be made for travel on the streets, roads, railroads and private ways.
- (5) Care shall be taken not to move, without the consent of the engineer, any sewers, drains, water or gas pipes, or other structures, and in crossing these, and in running parallel or near them, they shall be sustained securely in place until the work is completed. Whenever it is necessary to interfere with said structures, the Contractor shall maintain their respective services, and if necessary for that purpose, shall lay temporary water, gas or other pipes. The Contractor shall repair all damage done to any of said structures, and shall leave them in as good condition as they were previous to the commencement of the work. If so directed by the engineer, permanent changes of location not indicated on the plans nor in specifications shall be made by the Contractor to meet the requirements of the sewer and appurtenances, and new work shall be added, when necessary, to leave all in good working order. The cost of such permanent changes not indicated on the plans nor in the specification is to be paid for as extra work, on the valuation of the Board of Public Works, and depending on the decision of the engineer as to whether the work done is or is not included in the work required by the Contractor under his contract. Any damage done or caused to said pipes or other existing structures by act or neglect on the part of the Contractor is to be paid by him.



Engineering Department

400 La Crosse St., La Crosse, WI 54601 • (608) 789-7505 • Fax: (608) 789-8184
<http://www.cityoflacrosse.org>

- (6) The Contractor shall be responsible for disposing of all excess dirt and debris resulting from construction. The City will not furnish a disposal site unless otherwise stated on the plans or in the Special Specifications.
- (7) No stone monuments, bench marks, etc., of any description, located in line of the work, shall be removed or taken up unless it be in the presence of the Engineer or City Inspector.

805.3.2 Backfilling

- (1) Natural backfill may be used in trenches and excavations which are not within 5' of or under pavement, driveways and sidewalks.
- (2) Trenches under pavement, driveways and sidewalks shall have approved sand backfill placed in 6" layers over the conduit. The remainder of the trench shall be filled with $\frac{3}{4}$ " Crushed Aggregate Base Course in 6" layers. Backfill material shall be mechanically compacted to a Minimum 95% of modified proctor. Trench backfill is considered incidental to the item of conduit or removal.
- (3) As the work progresses, all rubbish or refuse, and all unused materials and tools shall be removed at once from the ground. Whenever this clearing of rubbish from the streets, or the repairing of the street surfaces, fences or other damage is neglected, notice may be given to that effect to the Contractor, and if said rubbish is not removed or said repairs not done within two days thereafter, or if the Contractor does not at once take the necessary precautions to insure safety of public travel, the Board may employ other parties to do such work and the expense thus incurred will be deducted from any moneys due or that may become due the Contractor.
- (4) When, for any reason, the work is left unfinished, all excavations shall be filled if so required and the roadways and sidewalks be left unobstructed, and with the surfaces in a safe and satisfactory condition.
- (5) No excavated material, except the road surfacing, shall be left on the streets; but such materials shall be backfilled into the trench or carted away.

805.4 Testing, Acceptance, & Maintenance

- (1) **At the request of the Engineer or City Inspector**, the Contractor shall provide gradation testing for backfill material. The gradation test shall be incidental to the conduit or structure removal, install, or replacement.



810-LIGHTING BASES

810.1 General Description

- (1) This section will describe the removal and installation of light and lighting cabinet bases within the City of La Crosse right of way.

810.2 Materials

- (1) Concrete shall be of a composition in accordance with the general concrete construction within this document.
- (2) Steel reinforcement used within the concrete shall be in accordance with general steel reinforcement within this document.
- (3) Conduit used within the concrete shall be in accordance with general conduit within this document.
- (4) Fill material used shall be in accordance with general excavation within this document.
- (5) City shall provide anchor bolts for bases unless specified otherwise.

810.3 Construction Methods

810.3.1 Removals

- (1) Any conduits coming to and exiting the base shall be disconnected from the base by the contractor prior to removal of the base to protect the existing conduits. Any damage caused from removal will be the responsibility of the contractor to repair and be incidental.
- (2) Excavated area shall be filled with appropriate fill material and compacted to within the restoration area. The top area will be included under restoration. All fill will be incidental to the removal.
- (3) Light base removals shall include the following, but not limited to:
 - A. Equipment needed to dig out and remove base.
 - B. Equipment and material to fill and compact the resulting hole to within four (4) inches of final grade. Last four inches to be paid by restoration.
- (4) The Contractor shall dispose of old concrete bases at a site provided by the Contractor. Removed bases shall conform to backfilling operations.
- (5) The Contractor shall be responsible for disposing of all excess dirt, material, and debris resulting from construction. The City will not furnish a disposal site unless otherwise stated on the plans or in the Special Specifications

810.3.2 General Installation

- (1) Concrete bases shall be constructed in conformance the detail drawings contained in the plan.
- (2) The general locations of the bases are shown on the plans. The exact locations and elevations shall be established in the field by the Engineer. Unless otherwise specified, bases shall be placed with one side parallel to the center line of the street and the edge of the base shall be six (6) inches from the front of the sidewalk. The elevations of the bases shall be as shown on the applicable Standard Plate unless otherwise specified.
- (3) Where bases are to be installed within existing sidewalks or improved terraces, the Contractor shall remove and replace the entire stone of sidewalk or improved terrace affected by the installation unless otherwise specified or directed by the Engineer.
- (4) The contractor shall follow City of La Crosse Standard Procedures for excavation and backfilling operations.
- (5) Form depth shall be no more than six (6) inches below grade on the lower side of the base. Forming shall be removed after concrete has set. If a base requires a deep form because of loose dirt or fill, the form shall be removed before backfilling around the base. Backfill shall be tamped tight against the bare concrete base in layers of one (1) foot or less.
- (6) All forming and reinforcement shall be inspected prior to the contractor pouring the concrete. All conduit ends at the top of the concrete bases shall be plugged immediately after placement, and before concrete is poured.
- (7) Conduit height above the concrete base shall be 1 inch.



- (8) The maximum depth of all conduit shall be 36 inches except with written approval by the Engineer.
- (9) Anchor rods shall be installed with misalignments of less than 1:40 from vertical.
- (10) Top surfaces of concrete bases shall be trowel finished smooth and level.
- (11) Cure exposed portions of the concrete base as specified in concrete pavement section with a minimum cure time of 7 days or 3,500 psi.
- (12) Nonmetallic conduit shall have bell end installed. All conduit shall be sloped to pull box. Bell ends shall be installed on all PVC conduit exposed at the top of concrete bases before installation of cable or wire.
- (13) All bases shall have a one-inch chamfer around the top of the base.
- (14) All bases shall have two (2) conduits installed within six inches of the center of the base and to 24-30 inches below the ground with 90-degree elbows.
- (15) Conduits shall be at least 90-degrees apart from each other but be in the best location for connection to main conduit. Conduits shall have bell ends attached to protect wires.
- (16) City will provide anchor bolts, verification of bolt circle, pattern, and exposure for bases
- (17) The Contractor shall be responsible for disposing of all excess dirt, material, and debris resulting from construction. The City will not furnish a disposal site unless otherwise stated on the plans or in the Special Specifications

810.3.3 Beehive Base (BB)

- (1) Base should be precast or cast in place construction.
- (2) Base shall be 16 inches in diameter and 48 inches tall.
- (3) Base shall follow City of La Crosse Detail Drawing.

810.3.4 Beehive Base Alt (BBA)

- (1) Base should be precast or cast in place construction.
- (2) Base shall be 16 inches in diameter and 48 inches tall.
- (3) Base shall follow City of La Crosse Detail Drawing.

810.3.5 Postop/ Washington Base (PT&W)

- (1) Base should be precast or cast in place construction.
- (2) Base shall be 20 inches in diameter and 60 inches tall
- (3) Base shall follow City of La Crosse Detail Drawing.

810.3.6 Matchstick Base (MS)

- (1) Base shall be cast in place construction.
- (2) Base shall be 22 inches in diameter and 60 inches tall.
- (3) Top 12 inches shall be a 26-inch by 26-inch square cap.
- (4) Base shall follow City of La Crosse Detail Drawing.

810.3.7 Acorn Base (AC)

- (1) Base shall be cast in place construction.
- (2) Base shall be 20 inches in diameter and 84 inches tall.
- (3) Top 12 inches shall be a 26-inch by 26-inch square cap.
- (4) Base has reinforcement cage.
- (5) Base shall follow City of La Crosse Detail Drawing.

810.3.8 Cabinet Bases

- (1) Cabinet base shall be cast in place construction.
- (2) Cabinet base shall be 24 inches wide by 34 inches long by 30 inches high with 6 inches of reveal above the surrounding area
- (3) Installation location on plan is approximate and engineer will mark final locations once contractor has proper diggers ticket to minimize utility conflicts.



- (4) If cabinet cannot be placed next to the sidewalk a maintenance platform must be poured and will be incidental to the base.
- (5) Base shall follow City of La Crosse Detail Drawing.
- (6) Base shall have the following conduits:
 - A. Two (2) 3-inch conduits connected to the pull box
 - B. One (1) 2-inch conduit connected to the pull box
 - C. One (1) 1-inch conduit for the grounding rod

810.4 Measurement

- (1) The department will measure the removal items by a quantity of Each (EA).
- (2) The department will measure the Concrete Base Complete by a quantity of Each (EA).
- (3) The department will measure the Concrete Control Cabinet Base by a quantity of Each (EA).

810.5 Payment

The department will pay for the measured quantity at the contract unit price under the following bid item:

ITEM CODE	DESCRIPTION	UNIT
810.01	Remove Concrete Base	EA
810.02	Remove Cabinet Base	EA
811.01-.05	Modified Concrete Base Complete (Type)	EA
812	Concrete Control Cabinet Base	EA

810.6 Testing, Acceptance, & Maintenance

810.6.1 Underground Inspection

- (1) Contractor shall conform to Underground Inspection requirements in the City of La Crosse Standard Procedures.

810.6.2 Concrete Cylinders

- (1) Contractor shall prepare 3 cylinders according to AASHTO T23 and test the cylinders according to AASHTO T22.
- (2) If the strength of a cylinder is less than 90 percent of the required strength, the engineer will reject the resulting average. Contractor shall replace all concrete bases that fail the strength test at the contractors' expense before the base shall be accepted.
- (3) Contractor shall submit the compressive strength test results to the engineer for verification.

810.6.3 Maintenance

- (1) Contractor shall protect all extruding bolts and conduits until the structure is installed.



815-LIGHTING CONDUIT

815.1 General Description

- (1) This section will describe the removal, installation and connection to existing conduit.

815.2 Materials

- (1) Furnish conduit consistent with the inside diameter bid item indicated in the plan. Backfilling materials shall conform to City of La Crosse Standard Procedures.
- (2) Unless otherwise directed by the Engineer, all conduit and accessories shall be unloaded at the point of delivery, and hauled to and distributed at the site of the work by the Contractor. The materials shall be at all times handled with care to avoid damage. The material shall not be dropped or bumped against the ground, other pipe and accessories already on the ground, or any other object on the ground.
- (3) Unless otherwise specified, references to various standard specifications and test methods shall be understood to mean the specification or test method which is current on the date of awarding of bid.

815.2.1 Conduit

- (1) All conduit shall be rigid nonmetallic conduits shall be Schedule 40 PVC conforming to UL 651. Schedule 40 HDPE conforming to UL 651A may be used in lieu of Schedule 40 PVC for conduits to be installed by directional drilling.
- (2) Conduit and fittings shall be produced by the same manufacturer and be homogenous, virgin PVC C-300 compound free from visible cracks, holes or foreign inclusions. The conduit bore shall be smooth and free of blisters, nicks, or other imperfections which could mar conductors or cables.
- (3) Conduit and fittings shall be clearly marked with a UL label. The type and manufacturer shall be identified by legible and permanent markings.
- (4) All conduit and fittings shall be solvent welded in accordance with instructions from the manufacturer, and as directed by the Engineer. Solvent for welding PVC shall be clear, medium viscosity, with a fast set time, ASTM D 2564 or approved equal.
- (5) All conduits inside diameter shall not exceed a quarter of an inch difference between the outside diameter and inside diameter.
- (6) Electrical conduit shall be standard gray color.
- (7) Fiber conduit shall be orange in color and an internal tracer wire shall be incidental to the conduit for locating purposes.

815.2.2 Tracer Wire

- (1) Any tracer wires shall be a single conductor, stranded copper, XHHW insulated, USE rated and No. 12 A.W.G. and may be any color except Black, Red, Blue, White, or Green.

815.3 Construction Methods

815.3.1 Remove Conduit

- (1) Conduit shall be marked in the field by the engineer prior to start of work.
- (2) Any removals or damage caused beyond this point without the Engineer's permission will be the responsibility of the contractor to repair at their expense.

815.3.2 Conduit Empty

- (1) Natural backfill may be used in trenches and excavations which are not within 5' of or under pavement, driveways and sidewalks. Trenches under pavement, driveways and sidewalks shall have approved sand backfill placed in 6" layers over the conduit. The remainder of the trench shall be filled with $\frac{3}{4}$ " Crushed Aggregate Base Course in 6" layers. Backfill material shall be mechanically compacted to a minimum of 95% of modified proctor. Trench backfill is considered incidental to the item of conduit.



Engineering Department

400 La Crosse St., La Crosse, WI 54601 • (608) 789-7505 • Fax: (608) 789-8184
http://www.cityoflacrosse.org

- (2) Each conduit run between access points to the wiring (e.g., handholes, pull boxes, poles) shall be one size for its entire length.
- (3) Electrical conduit shall be installed within the front one (1) foot of the sidewalk if directionally bored and shall be installed within one (1) foot of the back of curb or as near as practical to the back of curb, when it is being placed parallel to the curb unless specified otherwise by the Engineer or special Specification. It will, however, be the responsibility of the Contractor to locate all underground conduit in a manner to preclude damage to the duct resulting from subsequent construction.
- (4) Conduit shall be of the nominal inside diameter as the plans show. The Contractor may substitute a larger size of conduit than that specified for a run; however, any resulting additional costs shall be borne by the Contractor and no adjustment in compensation will be made.
- (5) All conduits shall be installed at a minimum depth of 30 inches below surface elevation.
- (6) Conduits shall be connected using proper fittings and adhesives. Conduits shall be free of joints, splices, or connections preventing safe, snag-free, non-damaging pulling of wire throughout. All conduit ends shall be carefully reamed and/or bushings to protect the wires.
- (7) All splices between reels of polyethylene conduit and connections to steel or PVC conduit shall be made with approved watertight coupling assemblies. Standard conduit fittings shall be used and all costs for couplings and joints shall be included in the unit price bid for the conduit.
- (8) When connections are to be made to an existing conduit, the Contractor shall first verify that the existing conduit is fully clear and useable for its entire cross-section and length. When the existing conduit is found to be defective, the Contractor shall notify the Inspector and not proceed until the Inspector so directs. If the Contractor connects to an existing defective conduit without the express direction from the Inspector, the Contractor shall make any and all necessary repairs and replacements to all conduits, including conduit that was "existing" prior to the Contractor starting work. All costs of this work shall be at the expense of the Contractor.
- (9) All fiber conduit and empty conduit shall have a tracer wire installed within the conduit, including conduit connecting to existing conduit. The tracer wire shall be approximately four (4) feet longer than the conduit run and shall be doubled back for at least two (2) feet at each terminal. Anchor the tracer wire at each access point. The cost of tracer wire shall be incidental to the cost of conduit unless specified otherwise in the Special Provisions.

815.3.3 Cut, Couple, and/or Connect Conduit

- (1) The contractor is to cut the main conduit and connect into the conduits in the light base. All joints are to be watertight. The connectors or adhesive shall be able to transition from the HDPE conduit to schedule 40 PVC to connect into the base conduits.

815.4 Measurement

- (1) The department will measure Remove conduit by the linear foot (LF).
- (2) The department will measure Conduit Empty by a quantity of Linear Foot (LF).
- (3) The department will measure Cut, Couple, and/or Connect by a quantity of Each (EA). If distance from front of sidewalk to light base is greater than three feet, the extra conduit will be paid for under the lighting conduit material only bid item.

815.5 Payment

The department will pay for the measured quantity at the contract unit price under the following bid items:

ITEM CODE	DESCRIPTION	UNIT
815	Remove Conduit	LF
816.01-.06	Conduit Empty (Size, Install Type)	LF
817	Cut, Couple, and/or Connect Conduit at Bases	EA



Engineering Department

400 La Crosse St., La Crosse, WI 54601 • (608) 789-7505 • Fax: (608) 789-8184
<http://www.cityoflacrosse.org>

815.6 Testing, Acceptance, & Maintenance

- (1) **At the request of the Engineer**, a mandrel at least six (6) inches in length and of the proper size shall be used during the inspection to ensure that the conduit is fully open for its entire length. The Contractor shall furnish all required tools, equipment and labor necessary to make the inspections. Any conduit found crushed or damaged, or determined by the Engineer to be unsatisfactory, shall be replaced by the Contractor at the Contractor's expense before the work will be accepted.

815.6.1 Underground Inspection

- (1) Contractor shall conform to Underground Inspection requirements in the City of La Crosse Standard Procedures.



820-PULL BOXES

820.1 General Description

- (1) This section describes the removal, adjustment, or installation of a new pull box.

820.2 Materials

- (1) Backfilling materials shall conform to City of La Crosse Standard Procedures.
- (2) Pull Box material shall conform to WisDOT Standard Specifications for Highway and Structure Construction.
- (3) Conduits shall conform to City of La Crosse Standard Procedures.
- (4) Furnish manhole frames and solid lids conforming to AASHTO M105, class 30 and be as follows:
 - A. Regular: R-5900-E, NF-0810 235
 - B. Locking: R-5900-E W/ Type G lock, NF-0810 235
- (5) All Frames and covers shall be heavy duty type, suitable for vehicular traffic loads and shall be stamped with "ELECTRIC" if regular.
- (6) Pull box covers Must be in compliance with the Public Rights of Way Accessibility Guidelines.
- (7) Pull box enclosures shall be comprised of the following components listed below. No individual component shall exceed 100 pounds in weight.
- (8) Main body with a depth of 36 or 42 inches, as specified in the plans, and must have minimum inside diameter of 24 inches. Must be field trim able for custom lengths. Must have an open bottom with 2 inch minimum continuous support foot and a maximum diameter of 33 inches.
- (9) Extension option of up to 12 inches. Must be field trimmable for custom lengths. Cover must be round in shape, maximum diameter of 28 inches, require a tool to open and have no threaded fasteners. Cover shall be embossed in letters at least $\frac{3}{4}$ inches high with "ELECTRIC" or as specified in the plans.
- (10) Cover support ring with a minimum opening diameter of 22 inches. Must be adjustable for slope corrections of up to 5%. Must be designed to bond to surrounding sidewalk, and allow for uniform cover/pavement vertical movement of up to 6 inches.

820.2.1 Steel Type

- (1) Furnish steel pull boxes made of corrugated steel pipe conforming to AASHTO M36 with annular corrugations.
- (2) Grounding wire shall be 10 AWG with NEMA approved UL listed mechanical connector and approved for use with copper wire.

820.2.2 Non-Conductive Type

- (1) Non-conductive pull boxes must be made of non-conductive materials conforming to all the requirements of the current edition of ANSI/SCTE 77 (SCTE 77) "Specifications for Underground Enclosure Integrity" and with the modified impact requirements. The tier rating and modified impact requirements are listed below.
 - A. Impact: Any portion of the enclosure shall withstand a 70 ft-lb impact administered by a weight having a "B" tup per ASTM D2444 without puncturing, splitting or cracking. The test is to be conducted at a temperature of -30 degrees Fahrenheit. The cover is tested while placed on the enclosure.
 - B. Enclosure, extension, ring and cover shall have a minimum Tier 15 rating as specified in SCTE 77. Tier rating must be accomplished and results provided with all methods of adjustability being proposed.

820.3 Construction Methods

- (1) Pull box installation shall conform to WisDOT Standard Detail Drawing and City of La Crosse Detail Drawing.
- (2) Provide pull boxes with manhole frames and solid lids. The contractor may extend pull boxes as the plans show using the same material as the pull box. Saw extensions parallel to the annular ring and clamp to the pull box using



Engineering Department

400 La Crosse St., La Crosse, WI 54601 • (608) 789-7505 • Fax: (608) 789-8184
<http://www.cityoflacrosse.org>

a band manufactured for this purpose. Excavate, place coarse aggregate drain material, and backfill as the plans show. Dispose of surplus or unsuitable material as specified in City of La Crosse Standard Procedures.

- (3) Entrance holes into pull boxes shall be cut with a circular hole saw or hydraulic conduit punch. Hole size shall be the outside diameter of the conduit that is to fit in the opening plus no more than 1/4". All conduit shall be pitched to drain to pull boxes.
- (4) Contractor shall not install wire in any pull box until its installation has been inspected and accepted by the engineer.
- (5) Grounding lug shall be installed per WisDOT Standard detail drawing and City of La Crosse Detail Drawing.
- (6) Under the Adjusting Pull Boxes bid item, move existing pull boxes to grade level. Excavate, adjust subsurface components as required, and backfill as the plan details show. Dispose of surplus or unsuitable material offsite.
- (7) Under the Removing Pull Boxes bid item, excavate and remove existing pull boxes. Backfill with material similar to the surrounding material. Dispose of surplus or unsuitable material offsite.

820.4 Measurement

- (1) The department will measure these items by a quantity of Each (EA).

820.5 Payment

The department will pay for the measured quantity at the contract unit price under the following bid item:

ITEM CODE	DESCRIPTION	UNIT
820	Remove Pull Box	EA
821.01-.02	Pull Box (Type)	EA
822	Adjust Pull Box	EA

820.6 Testing, Acceptance, & Maintenance

820.6.1 Underground Inspection

- (1) Contractor shall conform to Underground Inspection requirements in the City of La Crosse Standard Procedures.



825-LIGHTING WIRING

824.1 General Description

- (1) This section describes the removal and installation of new wiring.

825.2 Materials

- (1) All conductor wire shall be Underground Service Entrance (USE) designated.
- (2) The wire shall be 600-volt, 90 degrees C., Type XLP (62 mils crosslink polyethylene insulation) copper conductor and shall be in accordance with the latest edition of "I.P.C.E.A. General Specifications".
- (3) Wire sheathing must be a solid color. Colored tape will not be acceptable.
- (4) Tape or wire with a strip may be used to help denote wires where there are multiple hot wires of the same color to avoid cross wiring.

825.3 Construction Methods

825.3.1 Removal

- (1) All wire shall be turned over to the city once removed.

825.3.2 General

- (1) All wiring shall be continuous with no splices underground.
- (2) All wiring shall be pulled by hand and shall not be damaged or strained in any manner.
- (3) All connections shall be made in the cabinet or bases.
- (4) All connections shall be electrically and mechanically secure without solder.
- (5) For cables entering each pull box provide an extra loop, approximately 16 feet long, to remain in each pull box. This loop of cable is in addition to the quantity needed to reach from the entrance conduit raceway end to the opening in the exiting conduit raceway.
- (6) Each lighting base shall have an additional 8 feet of cable installed.
- (7) Wire colors shall be as follows:
 - A. Black- Lighting Circuit "A" or Festoon circuit if present
 - B. Red- Lighting Circuit "B"
 - C. Blue- Lighting Circuit "C"
 - D. White- Neutral Conductor
 - E. Green- Ground Conductor
- (8) Any tracer wires shall be a single conductor, stranded copper, XHHW insulated, USE rated and No. 12 A.W.G. and may be any color except Black, Red, Blue, White, or Green.
- (9) Wiring will follow the following schemes unless notes otherwise on plans and/or Section 16 in the special specifications.

825.3.3 7L Wiring

- (1) 7L shall consist of seven (7) total wires.
- (2) Wiring shall be 240V.
- (3) All wires will be No. 12 A.W.G wire.
- (4) Wiring shall be as follows:
 - A. Black, Red, and Blue two wires each- alternating lighting circuits
 - B. Green ground conductor

825.3.4 7LF Wiring

- (1) 7LF shall consist of seven (7) total wires.
- (2) Wiring shall be as follows:
 - A. Black festoon circuit – No. 2 A.W.G (120V)



Engineering Department

400 La Crosse St., La Crosse, WI 54601 • (608) 789-7505 • Fax: (608) 789-8184
http://www.cityoflacrosse.org

- B. Red, and Blue two wires each alternating lighting circuits- No. 10 A.W.G wire (240V)
- C. White neutral conductor- No. 2 A.W.G.
- D. Green ground conductor- sized appropriately for the application by the contractor

825.3.5 5L Wiring

- (1) 5L shall consist of five (5) total wires.
- (2) Wiring shall be 240V.
- (3) All wires will be No. 12 A.W.G wire.
- (4) Wiring shall be as follows:
 - A. Red, and Blue two wires each- lighting circuits
 - B. Green ground conductor

825.3.6 5HF Wiring

- (1) 5H shall consist of five (5) total wires.
- (2) Wiring shall be as follows:
 - A. Black festoon circuit – No. 4 A.W.G (120V)
 - B. Red, and Blue two wires each alternating lighting circuits- No. 4 A.W.G wire (120V)
 - C. White neutral conductor- No. 2 A.W.G.
 - D. Green ground conductor- sized appropriately for the application by the contractor

825.3.7 4H Wiring

- (1) 4H shall consist of four (4) total wires.
- (2) Wiring shall be as follows:
 - A. Red, and Blue two wires each alternating lighting circuits- No. 4 A.W.G wire (240V)
 - B. White neutral conductor- No. 2 A.W.G.
 - C. Green ground conductor- sized appropriately for the application by the contractor

825.4 Measurement

- (1) The department will measure this item by a quantity of Linear Foot (LF). The linear footage will be determined by the total length of conduit plus extra mentioned above per pull box installed, eight feet per base installed, and an extra crossing length.

825.5 Payment

The department will pay for the measured quantity at the contract unit price under the following bid item:

ITEM CODE	DESCRIPTION	UNIT
825	Wire Removal	LF
826.01-.05	Install New Wire Color Coded (Scheme)	LF

825.6 Testing, Acceptance, & Maintenance

825.6.1 Underground Inspection

- (1) Contractor shall conform to Underground Inspection requirements in the City of La Crosse Standard Procedures.

825.6.2 Aboveground Inspection

- (1) Contractor shall conform to Aboveground Inspection requirements in the City of La Crosse Standard Procedures.



830-POLES, ARMS, STANDARDS

830.1 General Description

- (1) This section describes the removal and installation of light poles.

830.2 Materials

- (1) Poles shall be steel or aluminum construction.
- (2) City shall provide contractor with poles unless specified otherwise.
- (3) All conductor wire shall conform to City of La Crosse Standard Procedures.

830.3 Construction Methods

830.3.1 Removals

- (1) Arrange for an inspection of all lighting equipment by representative from the City of La Crosse a minimum of five business days prior to removal.
- (2) Arrange for the de-energizing of the control cabinet and removal of existing electrical service with the local electrical utility after receiving approval from the engineer that the existing lighting can be removed.
- (3) All above ground lighting equipment and material noted on the plans to be removed shall be disconnected, disassembled, removed, and set aside in an easily accessible area or delivered to City of La Crosse Street Department.
- (4) Care shall be taken as to not damage luminaries. Replace any lighting equipment to be salvaged that is damaged in the removal process with equipment that is of equal quality to that of the damaged piece.
- (5) The Contractor shall be responsible for protecting all equipment and materials from damage during removal, salvaging, and delivery. This shall be considered incidental to the removal bid items.

830.3.2 General

- (1) City shall provide all poles and luminaires for install unless specified otherwise. Cut sheets are available upon request. Contractor shall schedule a pick-up time 5 business days in advance of material pick up from the municipal storage unit.
- (2) This shall include wire and any connectors for up the pole to connect luminaire to underground wiring.
- (3) All pole hand holes shall be installed toward the sidewalk if present or 180 degrees from the road for safety.
- (4) All wires shall have fused break away holders sized properly for wire to connect the above ground wires to the underground wires as follows.
 - A. 240V Lighting shall be a dual fuse holder with 10-amp fuses.
 - B. 120V lighting shall be single fuse holders with 10-amp fuses.
 - C. Festoon shall be a single fuse holder with a 15-amp fuse.

830.3.3 Acorn (AC)

- (1) Acorn poles have an approximate overall height of 27 feet tall.
- (2) A 22-foot 4-inch tall pole with banner arms and festoons unless at a corner than pole will be smooth from top to bottom.
- (3) Pole to be mounted to a transformer base.
- (4) Decorative base to slide down pole or clam shell around.
- (5) A six-foot long mast arm.
- (6) A 150-watt HPS lamp or LED equivalent.

830.3.4 Cobra Head (CH)

- (1) Cobra Head poles will have an approximate overall height of between 25 feet and 30 feet.
- (2) Pole will have mast arm varying from six feet to 12 feet and maybe integrated as one with the pole.



- (3) A 100-400-watt HPS lamp or LED equivalent.

830.3.5 Matchstick (MS)

- (1) Matchstick light has an overall approximate height of 16 feet tall.
- (2) A 13-foot 6-inch with festoon outlets and banner arms unless specified otherwise.
- (3) An 18-inch globe optic
- (4) A 150-watt HPS lamp or LED Equivalent.

830.3.6 5-Globe (5G)

- (1) An overall height of approximately 18' tall.
- (2) A 13'-6" pole with Festoon outlet.
- (3) Four 12" Diameter and one 18" diameter optic globes.
- (4) Four 50-watt HPS Lamps and one 70-watt HPS Lamp

830.3.7 3-Globe (3G)

- (1) An overall height of approximately 15' tall.
- (2) A 12' pole with festoon outlet.
- (3) Three 18" globes.
- (4) Three 150-watt HPS lamps.

830.3.8 2-Globe (2G)

- (1) An overall height of approximately 15' tall.
- (2) A 12' pole with festoon outlet.
- (3) Two 18" globes.
- (4) Two 150-watt HPS lamps.

830.3.9 Area (AR)

- (1) An overall height of approximately 16' tall.
- (2) A 14' tall beehive base pole.

830.3.10 Postop or Washington (PT & W)

- (1) An overall height of approximately 16' tall.
- (2) A 12' pole height
- (3) May also include festoon outlet.

830.4. Measurement

- (1) The department will measure these removal items by a quantity of Each (EA).
- (2) The department will measure these items by a quantity of Each (EA).

830.5. Payment

The department will pay for the measured quantity at the contract unit price under the following bid items:

ITEM CODE	DESCRIPTION	UNIT
830	Remove Light Pole (pole)	EA
831.01-.08	Assemble, Wire, and Install Poles Complete (Type)	EA

830.6 Testing, Acceptance, & Maintenance

830.6.1 Aboveground Inspection

- (1) Contractor shall conform to Aboveground Inspection requirements in the City of La Crosse Standard Procedures.



835-LIGHTING CONTROL CABINET

835.1 General Description

- (1) This section describes the transport and installation of a lighting control cabinet within the project limits.

835.2 Materials

835.2.1 Control Cabinet

- (1) City of La Crosse shall furnish the lighting control cabinet. Contractor shall schedule a pick-up time 5 business days in advance of material pick up from the municipal storage unit.
- (2) Contractor shall furnish other needed materials in conformance with WisDOT Standard Specifications for Highway and Structure Construction.

835.2.2 Electrical Meter

- (1) Electrical Meter Service shall conform to NEC code and local energy provider requirements.
- (2) Contractor shall furnish conduit fittings, grounding electrodes, and connections and necessary conductors and equipment required to provide power to the cabinet.

835.3 Construction Methods

835.3.1 Salvage Lighting Control Cabinet

- (1) Arrange for an inspection of lighting control cabinet by representatives from the City of La Crosse a minimum of five business days prior to removal. This inspection is intended to provide an inventory and assessment of the original condition of the equipment and to determine what equipment the City of La Crosse would like to retain.
- (2) Arrange for the de-energizing of the lighting control cabinet and removal of existing electrical service with the local electrical utility after receiving approval from the engineer that the existing lighting control cabinet can be removed.
- (3) Lighting control cabinet components are to be removed and secured in a box prior to detaching the cabinet from the base. Lighting control cabinet and its components shall be delivered to City of La Crosse Street Department.
- (4) Care shall be taken as to not damage remaining equipment. Replace any equipment to be salvaged that is damaged in the removal process with equipment that is of equal quality to that of the damaged piece.
- (5) The Contractor shall be responsible for protecting all equipment and materials from damage during removal, salvaging, and delivery. This shall be considered incidental to the removal bid items.

835.3.2 Lighting Control Cabinet

- (1) Install the field cabinet on a new or existing concrete base paid separately.
- (2) The contractor will be responsible for all permits and arranging for on-site inspection-inspection of the cabinet by the City of La Crosse Building & Inspections Department Electrical Inspector.
- (3) The contractor shall also be responsible for contacting and coordinating with Xcel Energy to get power to the cabinet. City will provide work order numbers if locations were submitted for design to Xcel prior to start of project.

835.3.3 Electrical Meter

- (1) Install the electrical service conforming to Xcel Energy requirements. Furnish Xcel Energy with a wiring affidavit, certifying that the service was installed conforming to the WSEC. The City will be responsible for any charges from Xcel Energy service installation or relocation and energy cost will be billed to and paid for by the City.
- (2) Install the cabinet first, so the electrical utility company can install the service lateral. Finish grade the service trench, replace topsoil that is lost or contaminated with other materials.

835.4. Measurement

- (1) The department will measure Remove Lighting Cabinet by a quantity of Each (EA).
- (2) The department will measure Lighting Control Cabinet Installation item by a quantity of Each (EA).



Engineering Department

400 La Crosse St., La Crosse, WI 54601 • (608) 789-7505 • Fax: (608) 789-8184
<http://www.cityoflacrosse.org>

835.5. Payment

The department will pay for the measured quantity at the contract unit price under the following bid item:

ITEM CODE	DESCRIPTION	UNIT
835	Remove Lighting Cabinet	EA
836.01-.03	Lighting Control Cabinet Installation (Type)	EA

835.6 Testing, Acceptance, & Maintenance

- (1) The lighting control cabinet installation is not complete until the electrical work is complete and electrical systems work properly for 72 hours.



850-BRICK PAVERS

850.1 General Description

- (1) This section describes the removal, installation and repair of streetscape paver bricking within project limits.

850.2 Materials

- (1) Bricks should to be from Interlock Concrete Products Inc or a city approved equal. Pavers shall be ASTM C 936 compliant. They shall be Holland Style 4"x8"x2 3/8" (6cm) in the normal or 5"x10"x3 1/8" (8cm) in the permeable paver. The following colored bricks are approved:
 - A. Red/red/charcoal blend known as "Rosewood" or "La Crosse Blend"
 - B. Charcoal Gray or "Onyx Black"
 - C. Red/tan blend known as "Buff"
- (2) Base material used shall be in accordance with general base material within this document.
- (3) Sand for leveling shall be a fine, sharp, non-plastic aggregate complying with ASTM C 33.
- (4) Normal brick joints shall be filled with a sand that is a fine, sharp, masonry sand with 100 percent passing the No. 16 (1.18 mm) sieve and no more than 10 percent passing the No. 200 (0.075 mm) sieve.
- (5) Permeable brick joints shall be filled with a 1/4" granite material. Sand or limestone fill will not be accepted.

850.3 Construction Methods

850.3.1 General

- (1) All brick pavers shall be wrapped in plastic or use other packaging materials that will prevent rust marks from steel strapping.
- (2) Protect unit pavers and aggregate during storage and construction against soilage or contamination from earth and other materials.
- (3) During cold weather, do not use frozen materials or materials mixed or coated with ice or frost. Do not install unit pavers on frozen subgrade or setting beds. Remove and replace unit paver work damaged by frost or freezing. Heating of frozen ground is not allowed
- (4) Do not use unit pavers with chips, cracks, voids, discolorations, and other defect that may be visible or cause staining in finished work.
- (5) Mix pavers from several pallets or cubes as they are placed to produce uniform blend of colors and textures.
- (6) Cut unit pavers with motor-driven masonry saw equipment to provide clean, sharp edges, free of chips. Cut units to provide pattern indicated and to fit adjoining work neatly. Use full units and halves without cutting where possible. Hammer cutting is not acceptable. A block splitter may be used for concrete pavers. Cutting is incidental to the item
- (7) Tolerances: do not exceed 1/32-inch (0.8-mm) unit-to-unit offset from flush (lippage) nor 1/8 inch in 10 feet (3 mm in 3 m) from level, or indicated slope, for finished surface of paving.

850.3.2 Removal

- (1) Areas for removal shall be shown on plans or marked in the field by the engineer.
- (2) Only full and half cut bricks free from defects are to be salvaged unless specified otherwise in the special specifications. Any other bricks shall be properly discarded by the contractor.
- (3) Contractor shall be responsible for protecting any salvaged bricks.
- (4) Multiple colors may be stacked on the same pallet as long as they are separated vertically on the pallet.
- (5) Pallets shall be delivered to the City of La Crosse Street Department.

850.3.3 Installation

- (1) Paver structure shall follow detail G on page D-8-1 of the City of La Crosse Standard Detail Drawings.
- (2) Subgrade shall be compacted uniformly to at least 95 percent of ASTM D 1557 laboratory density.



- (3) Place aggregate base and subbase in thicknesses indicated. Compacted by tamping with plate vibrator and screed to depth required to allow setting of pavers. Overlay with geotextile fabric.
- (4) Place sand for leveling course (overtop geotextile fabric) and screed to a thickness of 1 to 1-1/2 inches (25 to 38 mm), taking care that moisture content remains constant and density is loose and constant until pavers are set and compacted. Leveling base shall be treated with a soil sterilizer to prohibit growth of grass and weeds.
- (5) Set pavers with a minimum joint width of 1/16 inch (1.5 mm) and a maximum of 1/8 inch (3 mm), being careful not to disturb leveling base. If pavers have spacer bars, place pavers hand tight against spacer bars. Use string lines to keep straight lines. Fill gaps between units that exceed 3/8 inch (10 mm) with pieces cut to fit from full-size unit pavers
- (6) Vibrate pavers into leveling course with a low-amplitude plate vibrator capable of a 3500- to 5000-lbf (16- to 22-kN) compaction force at 80 to 90 Hz. Perform at least 3 passes across paving with vibrator. Vibrate under the following conditions:
 - A. After edge pavers are installed and there is a completed surface or before surface is exposed to rain.
 - B. Before ending each day's work, fully compact installed concrete pavers within 36 inches (900 mm) of the laying face. Cover the open layers with non-staining plastic sheets overlapped 48 inches (1200 mm) on each side of the laying face to protect it from rain.
- (7) Spread dry sand and fill joints immediately after vibrating pavers into leveling course. Vibrate pavers and add sand until joints are completely filled, then remove excess sand. Leave a slight surplus of sand on the surface for joint filling.
- (8) Do not allow traffic on pavers until sand has been vibrated into joints.
- (9) Repeat joint-filling process 30 days later

850.3.3.1 La Crosse Pattern

- (1) The La Crosse Pattern shall use the La Crosse blend and gray colored bricks.
- (2) The gray brick pavers shall be a one brick wide boarder around the entire perimeter.
- (3) The La Crosse blend shall fill in the remaining area in a herringbone pattern.

850.3.3.2 Desert Pattern

- (1) The Desert Pattern shall use only the desert brick.
- (2) The brick pavers shall be run in a standard running bond pattern parallel to the street for the entire area.

850.3.4 Repair

- (1) Brick pavers shall be removed in a manor to reduce the likely hood of damage to the brick.
- (2) If brick pavers are damaged, the contractor will be responsible to dispose of the brick and supply replacement bricks of the same color unless stated in the special specifications that the city has some available.
- (3) No more than one quarter of an inch of sand may be added to re level the brick pavers.
- (4) Sand shall be excavated and geotextile cut so base material can be added and compacted by hand means to make up the difference if more than of a quarter of an inch of sand is need. A new piece of geo textile shall overlap 12 inches on either side of the cut and sand and pavers reinstalled.

850.4 Measurement

- (1) The department will measure this item by a quantity of Square Foot (SF).
- (2) The department will pay this item by the quantity of Square Foot (SF) of pavers laid. Areas within the paver area where pavers are not applicable will not be include. These would include v-loc supports, light bases, and valves but are not limited to these.

850.5 Payment

The department will pay for the measured quantity at the contract unit price under the following bid item:



Engineering Department

400 La Crosse St., La Crosse, WI 54601 • (608) 789-7505 • Fax: (608) 789-8184
<http://www.cityoflacrosse.org>

ITEM CODE	DESCRIPTION	UNIT
850	Remove, Palletize, and Deliver Bricks	SF
851.01-.04	Brick Paver System, Complete (Type)	SF
851.05-.08	Brick Paver Repair (Type)	SF

850.6 Testing, Acceptance, & Maintenance

N/A



860-CONCRETE EDGING

860.1 General Description

- (1) This section describes the different one-foot concrete edging used in the City of La Crosse streetscaping.

860.2 Material

- (1) Concrete shall be of a composition in accordance with the general concrete construction within this document.
- (2) Steel reinforcement used within the concrete shall be in accordance with general steel reinforcement within this document.

860.3 Construction

- (1) Concrete edging shall be constructed in accordance to one of the following:
- (2) All reinforcement shall be incidental in the installation of all edging.

860.3.1. Flat Edging

- (1) The flat edging shall conform to City of La Crosse Standard Detail Drawing.
- (2) It shall be one foot wide and eight inches thick.
- (3) The edging shall run from the top of curb to the front of the sidewalk.
- (4) The edging shall be tied to the sidewalk a minimum of six inches embedment.

860.3.2. Raised Edging

- (1) The tree edging shall conform to City of La Crosse Standard Detail Drawing.
- (2) It shall be one foot wide and vary from ten to eight inches thick.
- (3) It shall have four inches cutouts if it runs parallel with the sidewalk following Section A-A for spacing.
- (4) All edging shall be tied to the sidewalk with a minimum of six inches embedment.
- (5) There shall also be a single number four rebar centered the entire length of the edging.

860.4 Measurement

- (1) The department will pay this item by the quantity of Linear Foot (LF).

860.5 Payment

The department will pay for the measured quantity at the contract unit price under the following bid items:

ITEM CODE	DESCRIPTION	UNIT
860.01-.02	Concrete Edging (Type)	LF

860.6 Testing, Acceptance, & Maintenance

N/A



865-MULCH

865.1 General Description

- (1) This section describes the installation of mulch within the project limits.

865.2 Material

- (1) Mulch shall be of shredded bark type of mulch.
- (2) Mulch shall be a dark brown in color
- (3) Finely divided, granular type, and freshly chipped wood clippings will be acceptable.

865.3 Construction

- (1) The mulch is to be placed at to a depth of 4".
- (2) Contractor shall take care with stock pile of material onsite as to prevent unwanted migrating of material within the project boulevard area or entire flow line of curb.
- (3) Contractor shall not install excess amounts of material above placement area or mounding around tree. Mulch is incidental to new tree planting Items.

865.4 Measurement

- (1) The department will pay this item by the quantity of Square Foot (SF) placed.

865.5 Payment

The department will pay for the measured quantity at the contract unit price under the following bid items:

ITEM CODE	DESCRIPTION	UNIT
865	Mulch	SF

865.6 Testing, Acceptance, & Maintenance

N/A



870-INSTALL V-LOC SIGN SUPPORT

870.1 General Description

- (1) This section describes the installation of a V-LOC sign support system.

870.2 Material

- (1) Concrete shall be in accordance with the general concrete construction within this document.
- (2) City will provide the V-LOC unit to the contractor.

870.3 Construction

- (1) The supports shall be one foot by one foot by eight inches tall.
- (2) V-LOC support shall be installed level and plumb.
- (3) Installation shall conform to City of La Crosse Standard Detail Drawing.
- (4) Locations of L-LOC's will be marked by project engineer in the field prior to installation.

870.4 Measurement

- (1) The department will measure this item by a quantity of Each (EA).

870.5 Payment

The department will pay for the measured quantity at the contract unit price under the following bid items:

ITEM CODE	DESCRIPTION	UNIT
870	Install V-Loc Sign Support	EA

870.6 Testing, Acceptance, & Maintenance

N/A



875-INSTALL NEW VALVE BOX TOP

875.1 General Description

- (1) This section describes the installation of a valve box top.

875.2 Material

- (1) Concrete shall be of a composition in accordance with the general concrete construction within this document.
- (2) The cast valve box top will be supplied by the city.

875.3 Construction

- (1) The valve box top shall conform to City of La Crosse Standard Detail Drawing.
- (2) The valve box top may or may not have fingers welded on it.
- (3) The top is 16 inches long with a one foot by one foot by four-inch concrete collar poured.

875.4 Measurement

- (1) The department will pay this item by the quantity of Each (EA).

875.5 Payment

The department will pay for the measured quantity at the contract unit price under the following bid items:

ITEM CODE	DESCRIPTION	UNIT
875	Install new Valve Box Top	EA

875.6 Testing, Acceptance, & Maintenance

N/A



880-SAW CUT V-SHAPE TOOL JOINT

880.1 General Description

- (1) This section describes the procedure of saw cutting the V-shape tool joint into existing sidewalk

880.2 Material

- (1) Materials are as is in the field.

880.3 Construction

- (1) The joint shall conform to the City of La Crosse Standard Detail Drawing.
- (2) Joint shall be placed 12 inches from the front of walk. Contractor shall have a saw capable of duplicating the profile of a tooled joint. Saw shall be in accordance with the sawing procedure within this document.
- (3) Project engineer shall give the final approval of the depth of the sawn joint before all is cut in.

880.4 Measurement

- (1) The department will pay this item by the quantity of Linear Foot (LF).

880.5 Payment

The department will pay for the measured quantity at the contract unit price under the following bid items:

ITEM CODE	DESCRIPTION	UNIT
880	Saw Cut V-Shape Tool Joint	LF

880.6 Testing, Acceptance, & Maintenance

N/A



9. TRAFFIC

- 900 CONCRETE MEDIAN
- 905 GENERAL SIGNAL CONSTRUCTION
- 906 EXCAVATION AND BACKFILL
- 910 SIGNAL BASES
- 915 SIGNAL CONDUIT
- 920 PULL BOXE AND COMMUNICATION VAULT
- 925 SIGNAL WIRING
- 930 SIGNAL POLES, ARMS, STANDARDS
- 940 SIGNAL HEADS
- 945 SIGNAL CABINET EQUIPMENT
- 950 SIGNAL SPECIALTY EQUIPMENT
- 955 TEMPORARY SIGNAL
- 960 SIGNAL COMMUNICATION EQUIPMENT
- 970 PAVEMENT MARKING GENERAL
- 980 DELINIATOR POSTS



9. TRAFFIC

900-CONCRETE MEDIAN

900.1 General Description

- (1) This section describes the procedure for construction of median and refuge islands within the City of La Crosse right of way.

900.2 Materials

- (1) Concrete shall be in accordance with the general concrete construction within this document.
- (2) Steel reinforcement used within the concrete shall be in accordance with general steel reinforcement within this document.
- (3) Base material used shall be in accordance with general base material within this document.

900.3 Construction Methods

- (1) Any removals shall be performed under items in the standard removal items.
- (2) Median or island location shall be marked by the project engineer prior to the start of the project. Any area outside of this area without prior approval will not be paid for.

900.3.1 Median Sidewalk

- (1) Sidewalk shall be six-foot-wide, same length as the width of the median, and a minimum of six inches thick.
- (2) It will have two truncated dome warning fields install. The installation of these will be paid for under the truncated dome warning field bid item.
- (3) Cross section detail of road will be provided on the plans.
- (4) Sidewalk shall follow the street cross-slope.

900.3.1.1 Concrete Street

- (1) Sidewalk shall be tied to the existing concrete under the bituminous overlay with standard ties at three foot on center spacing on the sides and one centered on the width at each end.
- (2) Base material may be placed and compacted to achieve desired sidewalk thickness or poured thicker.
- (3) Ties, base material, or extra concrete shall be incidental to this item.

900.3.1.2 Overlaid Street

- (1) Sidewalk shall be tied to the existing concrete under the bituminous overlay with standard ties at three foot on center spacing on the sides and one centered on the width at each end.
- (2) Sidewalk shall be flush with the overlay.
- (3) Base material may be placed and compacted to achieve desired thickness or poured thicker.
- (4) Ties, base material, or extra concrete shall be incidental to this item.

900.3.1.3 Bituminous Street

- (1) Any excavation needed to achieve minimum thickness shall be incidental to this item.
- (2) Ties shall be drilled in and be spaced three foot on center on both sides of the sidewalk if sidewalk is poured separately from the islands to connect the islands to the sidewalk and shall be incidental to this item.

900.3.2 Exposed Island

- (1) Exposed islands shall be six to eight inches of exposed concrete above the pavement height based on bid.
- (2) Island thickness shall be as shown in cross-section detail and priced according to thickness.



900.3.2.1 Concrete Street

- Islands shall be tied to the concrete underneath with standard ties.
- The first and last tie shall be 12 inches from the edge of the island.
- Ties shall be three feet on-center for the length of the island and have the following total number of ties per row based on the width of the island:

Width of Island	Total # of Ties
3-5	2
6-9	3
10-12	4
13+	5

900.3.2.2 Overlaid Street

- Islands shall be tied to the concrete underneath with standard ties.
- Extra concrete for thickness of overlay shall be incidental to this item
- The first and last tie shall be 12 inches from the edge of the island.
- Ties shall be three feet on-center for the length of the island and have the following total number of ties per row based on the width of the island:

Width of Island	Total # of Ties
3-5	2
6-9	3
10-12	4
13+	5

900.3.2.3 Bituminous Street

- Extra concrete for thickness of street shall be incidental to this item

900.4 Measurement

- The department will measure these items by a quantity of Square Foot (SF).

900.5 Payment

The department will pay for the measured quantity at the contract unit price under the following bid item:

ITEM CODE	DESCRIPTION	UNIT
900	Median Sidewalk	SF
901.01-.02	Exposed Concrete Island (Thickness)	SF

900.6 Testing, Acceptance, & Maintenance

N/A



905-GENERAL SIGNAL CONSTRUCTION

905.1 General Description

- (1) Perform work in accordance with the provisions of WisDOT Standard Specifications for Highway and Structure Construction except as hereinafter modified.
- (2) Traffic signal and street lighting construction shall consist of excavating the required trenches and tunnels; furnishing and laying therein the required conduit; placing cable-in-duct and/or signal cable; installing the required structures and appurtenances; backfilling the trenches; restoring the site of the work; and completing the work to the required lines and grades. All work shall be performed as shown on the plans and in accordance with the contract.
- (3) The following requirements must be fulfilled before approval is given to commence work:
 - A. Contract forms to be completely executed.
 - B. Notice to utilities given.
 - C. Clearance from Engineer regarding disposal of surplus material, detouring of traffic, closing of streets and alleys, city facilities and services, shall be obtained by the Contractor.

905.2 Equipment & Materials

- (1) Equipment and tools necessary for performing all parts of the signal work shall be satisfactory as to design, capacity, and mechanical condition for the purposes intended, and any equipment which is not maintained in full working order, or which as used by the Contractor is inadequate to obtain the results prescribed, shall be repaired, improved, replaced, or supplemented to obtain the progress and workmanship contemplated by the contract.
- (2) The Concrete used in the construction and installation of signal bases and signal cabinet bases shall conform to the requirements for General Concrete as specified in the City of La Crosse Standard Procedures.
- (3) All Concrete, Bituminous, and gravel pavements, sidewalks, curbs and gutters, fences, boulevard restoration, or other structures which may have been damaged or displaced by the Contractor in constructing the traffic signal shall be rebuilt or re-laid properly to the original line and grade in accordance with City of La Crosse Standard Procedures, General Installations.
- (4) Portable job office shall be furnished by the Contractor during cold weather operations when requested by the Engineer. Suitable desk and bulletin board shall be provided as well as adequate heating and lighting facilities. The office shall be available to City Inspectors and other personnel designated at all times and shall be placed conveniently to the location of the work.
- (5) All electrical materials and their installation shall conform with the latest requirements of the National Electrical Code (NEC), Wisconsin Electrical Code and accepted standards of good workmanship. All materials for which a standard has been established by the Underwriters Laboratories, Inc. shall have their label firmly attached.
- (6) The Contractor shall provide for the Engineers approval 3 copies of shop drawings for all traffic signal and lighting equipment a minimum of 2 weeks prior to starting work. The Contractor shall not order any equipment until the shop drawings have been approved by the Engineer.
- (7) All materials which are to be furnished by the City shall be picked up by the Contractor at the Municipal Storage Unit, unless otherwise specified. Contractor shall schedule a pick-up time 5 business days in advance of material pick up. All costs of the work included in this Section shall be at the expense of the Contractor unless otherwise provided. The Contractor shall provide equipment and labor to load materials onto Contractor's vehicle or trailer. Complete quantities of an item shall be picked up on one appointment unless the City agrees to a partial quantity disbursement.



905.3 Construction Methods

- (1) Removal of all Concrete, asphalt, trees, brush, sidewalk, or other surface materials shall be done in compliance with the City of La Crosse Standard Specifications and Procedures.
- (2) The Contractor shall not, unless the proper parties have given written consent, enter or occupy with men, tools or materials any land adjoining the work.
- (3) The Contractor shall safeguard engineering stakes; and resetting, made necessary through carelessness of workmen, shall be done by the City at the Contractor's expense.
- (4) No cement work shall be done during freezing weather unless the Contractor shall provide the necessary means for, and shall heat the gravel, sand and water, and shall comply with all requirements to thoroughly protect the concrete from frost during curing; all at the cost and expense of the Contractor and with the approval of the Engineer.
- (5) The City Inspector shall be notified at least forty-eight (48) hours in advance of beginning any underground electrical construction work, such as installing cable-in-duct, PVC conduit and concrete bases, and shall be updated frequently as to stopping and restarting underground work. All underground conduit, cable, or concrete base forms shall be inspected by the City Inspector before any trench is backfilled or concrete is poured. Any work completed without such inspection is subject to rejection as unacceptable work and shall be immediately removed and acceptably replaced or otherwise satisfactorily corrected by and at the expense of the Contractor.
- (6) The existing signal and lighting poles, conduits, handholes, and manholes not scheduled for removal or abandonment shall be protected during construction. If the contractor believes that damage to such facilities is unavoidable, the contractor shall not damage or remove any facilities until the City Traffic Engineering electrical inspector has reviewed and approved such actions. Any damage or removal of City electrical conduit, wire, fiber, or structures, without the specific approval by the City Traffic Engineering electrical inspector shall be promptly repaired or replaced by and at the expense of the contractor. The City may elect to do repair work with City crews. The cost for any repair work done by the City will be billed to the contractor.
- (7) Any damage or removal of City street lighting, traffic signal, or communication facilities shall be repaired or replaced within 24 hours, but any resulting street light outage resulting from such damage or removal shall be confined to as few numbers of street lights as possible. The streetlight circuits shall remain operational each and every night. The City reserves the right to make temporary or permanent repairs at any time after the damage or removal, even within 24 hours of the damage or removal, with the full cost of such work, including engineering time, billed to the general contractor.
- (8) Unless a manhole (utility access structure), handhole, or structure is specifically designated for removal, it shall be saved. The contractor shall consult with the engineer or inspector before removing or damaging any existing facilities.

905.3.1 Dewatering

- (1) The Contractor shall keep all excavations free of water during and until completion of the work, as directed by the Project Engineer. The Contractor shall be responsible for the continuous control of water at all times during the course of construction, and shall provide adequate backup systems to accomplish control of water entering excavations, trenches, and other parts of the work and shall keep said excavations dry until the structures or utilities to be built therein are completed.
- (2) No concrete shall be installed in water nor shall water be allowed to rise over concrete at least twenty-four (24) hours after the concrete has been placed. Water shall be controlled during periods when concrete is being placed and as such other times as is necessary for efficient and safe execution of the work.
- (3) The Contractor shall protect all local water supplies from harm as a result of dewatering operations, and provide remedial measures for any situations where such harm occurs.



Engineering Department

400 La Crosse St., La Crosse, WI 54601 • (608) 789-7505 • Fax: (608) 789-8184
<http://www.cityoflacrosse.org>

- (4) All water removed from the construction site shall be discharged through pipes or hoses. The conveying of water in open ditches or trenches will not be allowed. Water shall be discharged in a manner that will not cause soil erosion at the discharge point. Discharge shall not cause siltation or flooding in any stream, storm sewer, or on adjacent properties.
- (5) All costs for making all extra excavations necessary to prevent the water from interfering with the proper construction of the work, bailing, pumping, and dewatering shall be borne by the Contractor, and included in the prices bid for other items of work. All required pumping, drainage, and disposal of groundwater shall be done without damage to adjacent property or structures, or to the operations of other Contractors and without interference with the access rights of public or private parties. The Contractor shall modify the water control system at their own expense if, after installation and while in operation, it causes or threatens to cause damage to adjacent property or to existing buildings, structures, or utilities.

905.3.2 Other Utilities

- (1) The location of pipes and other underground objects are approximately correct as shown on the plans, but should they be found to be otherwise, the Contractor shall have no claim on that account, it being understood that the Engineer does not warrant the plot of underground objects to be correct.
- (2) The Contractor shall notify all utilities, both public and private, including gas, electric, garbage collection, telephone, sewer and water, of his schedule of operations. The notice shall be given at least 48 hours prior to actual date of the commencing of construction. The Contractor shall also check as to any utility facilities which may be encountered during construction and take due notice of it.
- (3) The same notice and determination of facilities which may be encountered as well as to proposed blocking of streets or alleys shall be given to the Fire and Police Departments so as to enable them to maintain and plan their operations.
- (4) The Contractor shall give special attention to safeguarding and protecting all utilities, public and private, and shall be held liable for any damage thereto encountered during construction of the entire project.
- (5) Access to all hydrants and valves must be provided at all times because of emergency requirements of Water and Fire Departments.

905.3.3 Trees

- (2) The Contractor shall be responsible for trees damaged during the course of construction, as well as required trimming as directed by Engineering Department.

905.3.4 Personnel Requirements

- (1) Perform electrical work using a journey worker electrician or an electrical apprentice under the onsite supervision of a journey worker electrician. Before performing electrical work, provide the documentation specified below to the engineer proving that the electricians performing the work have attained status as journey worker and apprentice electricians.
- (2) Provide a completion certificate from a state apprenticeship program or a card issued by the Wisconsin department of safety and professional services to prove electricians are qualified.

905.3.5 Traffic Control

- (1) Contractor shall provide a detailed traffic control plan 10 business days prior to starting work to the engineering department for approval from the Traffic Engineer.

905.3.6 Finishing Work

- (1) The Contractor shall maintain all trenches and other excavations, keeping them well filled and in a safe condition for travel, and shall deliver to the City, at the time of acceptance, a finished job with all trenches in a condition satisfactory to the Engineer.
- (2) All concrete, asphalt, and gravel pavements; stone flagging or paving; sidewalks; curbs and gutters; culverts; fences; or other structures which may have been damaged or displaced by the Contractor shall be relaid properly to the



original line and grade. In areas with established and tended sod, the Contractor shall resod areas disturbed by the construction; all other areas disturbed by the construction shall be seeded. All of the above work shall be in accordance with these Specifications, or in absence of applicable specifications, to restore the original condition of the structure or area.

- (3) The Contractor shall restore and maintain all asphalt and gravel surfaces in first class condition until final acceptance of the project by the Common Council. All structures and conduit shall be cleaned of any accumulations of silt, debris or other foreign matter. Conduit shall be cleaned by use of the proper size mandrel. The area along the entire installation shall be left clean and graded in a condition satisfactory to the Engineer.
- (4) Unless otherwise provided, all costs of the work included in this Section shall be at the expense of the Contractor, and shall be included in the unit price bid for the contract items with which such work is associated. Final payment will be withheld until such work is done in a manner satisfactory to the Engineer.

905.4 Testing, Acceptance, & Maintenance

- (1) After installation and before final hookup, disconnect loads whether buried or not, and test grounded conductors, equipment grounding conductors, ungrounded conductors, and shielding contained in the cable with a megger. Submit the megger test results to the engineer. Ensure that the megger reads greater than 500 mega ohms during each of the following tests:
 - A. To ground.
 - B. Between each conductor.
 - C. Between each shield.
- (2) The Contractor shall furnish all equipment and appliances necessary to test all installed cable systems. The Contractor shall test and demonstrate to the satisfaction of the Engineer that the lighting circuits are properly connected and operational; continuous and free from short circuits and unspecified grounds; that they are connected in accordance with the wiring layout; and that with fuses removed the resistance to ground of nongrounded circuits between any two adjacent terminals is not less than five (5) megohms.
- (3) All cable shall be "Meggered" and the results recorded. All values shall be in accordance with standard practice for the lengths and type of cable used. All electrical circuits and equipment shall be tested and remain in operating condition.

905.4.1 Underground Inspection

- (1) Contractor shall inform the City when underground items are ready for inspection. The City Inspector or Engineer shall review all underground installations three (3) business days after inspection request from the contractor.
- (2) Contractor may inspect underground installations with the Inspector or Engineer.
- (3) Inspector shall use "Underground Inspection Form" and shall submit form to Contractor for correction or replacement. Underground items shall be corrected or replaced prior to pulling cable or installing above ground equipment.

905.4.2 Aboveground Inspection

- (1) Contractor shall inform the City when aboveground items are ready for inspection. The City Inspector or Engineer shall review all aboveground installations three (3) business days after inspection request from the contractor.
- (2) Contractor may inspect aboveground installations with the Inspector or Engineer.
- (3) Inspector shall use "Aboveground Inspection Form" and shall submit form to Contractor for correction or replacement. Aboveground items shall be corrected or replaced prior to scheduling signal turn on date.

905.4.3 Maintenance

- (1) Operate the completed traffic signal installation for 72 hours consecutively, using the specified signal sequence and all special functions, such as preemption, as the plans show, or as the engineer approves. The traffic signal installation is not complete until the electrical work is complete and electrical systems work properly.



Engineering Department

400 La Crosse St., La Crosse, WI 54601 • (608) 789-7505 • Fax: (608) 789-8184
<http://www.cityoflacrosse.org>

- (2) Operate the completed lighting installation for 20 consecutive nights without failure. Each component that fails shall be repaired or replaced and that component shall again be subject to the twenty-night proper working order test. The lighting system is not complete until electrical work is complete and inspected by the engineer, and electrical systems work properly.



906-EXCAVATION AND BACKFILL

906.1 General Description

- (1) Work in this section shall consist of excavations, preparation, and backfilling required for installation of or removal of traffic signal equipment.

906.2 Materials

906.2.1 Backfill Material

- (1) Backfill material shall conform to WisDOT Standard Specifications for Highway and Structure Construction. The use of reclaimed asphalt, reprocessed material, or blended material shall not be allowed.
- (2) Backfill material shall conform to WisDOT 1 ¼" dense graded base gradation. Excavated material may be used as backfill if it is suitable material in the judgement of the Engineer, is free from debris and organic material, and meets the gradation requirements.

906.3 Construction Methods

- (1) All excavations, auger, or backfilling material shall be incidental to the conduit or signal base.

906.3.1 Excavation

- (1) The excavations must either be sloped or supported as required to comply with OSHA Excavation standards as defined in 29 C.F.R. Part 1926, Subpart P.
- (2) The bottom of the trench is, in general, to be excavated to the exact form and size of the lower portion of the conduit or base which is to be laid in it.
- (3) Where salvageable material such as crushed rock or stone, of a depth of 6" or more, is encountered in excavation for installation, such material shall be carefully removed and segregated for future use by the City or as directed on the project by the Engineer. In such cases, the Engineer shall order removal and segregation of materials considered salvageable, where it shall be stored, and whether or not it is to be used by the Contractor in final backfilling operations on the project involved. Contractor shall be compensated for hauling of salvaged material on the same basis as for excess dirt or debris.
- (4) All materials shall be so placed as not to endanger the work, and so free access may be had at any time to all parts of the trench and all hydrants and gate valves in the vicinity. They shall be kept neatly piled so as to inconvenience as little as possible the public travel or the adjoining tenants. Reasonable provision shall be made for travel on the streets, roads, railroads and private ways.
- (5) Care shall be taken not to move, without the consent of the engineer, any sewers, drains, water or gas pipes, or other structures, and in crossing these, and in running parallel or near them, they shall be sustained securely in place until the work is completed. Whenever it is necessary to interfere with said structures, the Contractor shall maintain their respective services, and if necessary for that purpose, shall lay temporary water, gas or other pipes. The Contractor shall repair all damage done to any of said structures, and shall leave them in as good condition as they were previous to the commencement of the work. If so directed by the engineer, permanent changes of location not indicated on the plans nor in specifications shall be made by the Contractor to meet the requirements of the sewer and appurtenances, and new work shall be added, when necessary, to leave all in good working order. The cost of such permanent changes not indicated on the plans nor in the specification is to be paid for as extra work, on the valuation of the Board of Public Works, and depending on the decision of the engineer as to whether the work done is or is not included in the work required by the Contractor under his contract. Any damage done or caused to said pipes or other existing structures by act or neglect on the part of the Contractor is to be paid by him.



Engineering Department

400 La Crosse St., La Crosse, WI 54601 • (608) 789-7505 • Fax: (608) 789-8184
<http://www.cityoflacrosse.org>

- (6) The Contractor shall be responsible for disposing of all excess dirt and debris resulting from construction. The City will not furnish a disposal site unless otherwise stated on the plans or in the Special Specifications.
- (7) No stone monuments, bench marks, etc., of any description, located in line of the work, shall be removed or taken up unless it be in the presence of the Engineer or City Inspector.

906.3.2 Backfilling

- (1) Natural backfill may be used in trenches and excavations which are not within 5' of or under pavement, driveways and sidewalks.
- (2) Trenches under pavement, driveways and sidewalks shall have approved sand backfill placed in 6" layers over the conduit. The remainder of the trench shall be filled with $\frac{3}{4}$ " Crushed Aggregate Base Course in 6" layers. Backfill material shall be mechanically compacted to a Minimum 95% of modified proctor. Trench backfill is considered incidental to the item of conduit or removal.
- (3) As the work progresses, all rubbish or refuse, and all unused materials and tools shall be removed at once from the ground. Whenever this clearing of rubbish from the streets, or the repairing of the street surfaces, fences or other damage is neglected, notice may be given to that effect to the Contractor, and if said rubbish is not removed or said repairs not done within two days thereafter, or if the Contractor does not at once take the necessary precautions to insure safety of public travel, the Board may employ other parties to do such work and the expense thus incurred will be deducted from any moneys due or that may become due the Contractor.
- (4) When, for any reason, the work is left unfinished, all excavations shall be filled if so required and the roadways and sidewalks be left unobstructed, and with the surfaces in a safe and satisfactory condition.
- (5) No excavated material, except the road surfacing, shall be left on the streets; but such materials shall be backfilled into the trench or carted away.

906.4 Testing, Acceptance, & Maintenance

- (1) At the request of the Engineer or City Inspector, the Contractor shall provide gradation testing for backfill material. The gradation test shall be incidental to the conduit or structure removal, install, or replacement.



910- SIGNAL BASES

910.1 General Description

- (1) This section consists of removing and constructing concrete bases with the necessary hardware for traffic signal standards, RRFB poles, monotubes, and cabinets.

910.2 Materials

- (1) Backfilling materials shall conform to City of La Crosse Standard Procedures.
- (2) Signal Base material shall conform to WisDOT Standard Specifications for Highway and Structure Construction.
- (3) Concrete shall conform class II or class III general requirements as defined in the City of La Crosse Standard Procedures and WisDOT Standard Specifications for Highway and Structure Construction.
- (4) All reinforcing steel shall conform to WisDOT Standard Specifications for Highway and Structure Construction.
- (5) Use schedule 40 PVC electrical conduit conforming to WisDOT Standard Specifications for Highway and Structure Construction.
- (6) Unless otherwise specified, references to various standard specifications and test methods shall be understood to mean the specification or test method which is current on the date of awarding of bid.

910.2.1 Type 1 & Type 2 base

- (1) Anchor rods shall conform to ASTM F1554 grade 105 and Supplementary Specification S4, ASTM A563 nuts, and ASTM F436 washers.

910.2.2 Type 1 Modified base

- (1) Type 1 Modified base shall be constructed without conduit.
- (2) Anchor rods shall conform to ASTM F1554 grade 105 and Supplementary Specification S4, ASTM A563 nuts, and ASTM F436 washers.

910.2.3 Type 10 & Type 13 base

- (1) Anchor rod assemblies with top and bottom templates include rods, nuts, and washers conforming to WisDOT Standard Specifications for Highway and Structure Construction.
- (2) Furnish bottom template left in place conforming to WisDOT standard detail drawing for Type 10 base and for Type 13 base.

910.2.4 Type 10 Special base

- (1) Anchor rod assemblies with top and bottom templates include rods, nuts, and washers conforming to WisDOT Standard Specifications for Highway and Structure Construction.
- (2) Furnish bottom template left in place conforming to WisDOT standard detail drawing for Type 10 Special base and for Type 13 Special base.

910.2.5 Signal Cabinet base

- (1) Furnish mechanical stainless steel masonry anchors and stainless steel bolts or studs, nuts, and washers.
- (2) Stainless steel concrete masonry anchors shall conform to WisDOT Standard Specifications for Highway and Structure Construction. Anchors shall be ½ inch minimum diameter x 4-inch minimum length with a pullout strength of 9,000 lbs.

910.3 Construction Methods

910.3.1 Removal

- (1) These items shall include any material and necessary tasks to excavate, remove, and backfill. The contractor shall follow City of La Crosse Standard Procedures for excavation and backfilling operations. Removals are shown on plans and/or by field markings done by Engineer. Any removals or damage caused beyond this point without the Engineer's permission will be the responsibility of the contractor to repair at their expense.



- (2) Contractor shall remove all above ground equipment. Wire shall be pulled back to the nearest pull box. Conduit entering base shall be cut outside of the base to reduce damage to remaining equipment.
- (3) All concrete is to be disposed of in the proper manner. Signal base items shall include the following but not limited to:
 - A. Equipment needed to dig out and remove base.
 - B. Equipment and material to fill and compact the resulting hole to within four (4) inches of final grade. Last four inches to be paid by restoration.

910.3.2 General Base Construction

- (1) Concrete bases shall be constructed in conformance the detail drawings contained in the plan.
- (2) Signal base and signal cabinet base construction shall conform to WisDOT Standard Specifications for Highway and Structure Construction except as modified hereafter.
- (3) The general locations of the bases are shown on the plans. The exact locations and elevations shall be established in the field by the Engineer. Unless otherwise specified, bases shall be placed with one side parallel to the center line of the street and the center of the base shall be four (4) feet from the face of the curb. The elevations of the bases shall be as shown on the applicable Standard Plate unless otherwise specified.
- (4) Installations shall include equipment to auger or excavate the base location.
- (5) Where bases are to be installed within existing sidewalks or improved terraces, the Contractor shall remove and replace the entire stone of sidewalk or improved terrace affected by the installation unless otherwise specified or directed by the Engineer.
- (6) Form depth shall be no more than six (6) inches below grade on the lower side of the base. Forming shall be removed after concrete has set. If a base requires a deep form because of loose dirt or fill, the form shall be removed before backfilling around the base. Backfill shall be tamped tight against the bare concrete base in layers of one (1) foot or less.
- (7) All forming and reinforcement shall be inspected prior to the contractor pouring the concrete. All conduit ends at the top of the concrete bases shall be plugged immediately after placement, and before concrete is poured.
- (8) Conduit height above the concrete base shall be 1 inch.
- (9) The maximum depth of all conduit shall be 36 inches except with written approval by the Engineer.
- (10) Anchor rods shall be installed with misalignments of less than 1:40 from vertical.
- (11) Top surfaces of concrete bases shall be trowel finished smooth and level.
- (12) Cure exposed portions of the concrete base as specified in concrete pavement section with a minimum cure time of 7 days or 3,500 psi.
- (13) Nonmetallic conduit shall have bell end installed. All conduit shall be sloped to pull box. Bell ends shall be installed on all PVC conduit exposed at the top of concrete bases before installation of cable or wire.

910.3.3 Type 1 and Type 2 Base

- (1) Bases shall be excavated by use of a circular auger.
- (2) Conduit sizes and locations shall be shown on the plans.
- (3) Anchor rods shall be threaded 12" in length on each end of the rod. Anchor rods shall be manufactured in accordance with WisDOT Standard Specifications for Highway and Structure Construction.
- (4) Washers and lock washers are required on all anchor rods.
- (5) A NO. 4 AWG, stranded copper equipment grounding conductor shall be exothermically welded to the Grounding Rod for Type 2 bases. The equipment grounding conductor shall be furnished and installed to enter the base, through a 3/4 inch conduit installed for grounding purposes, leaving a four (4) foot coil of wire above the concrete base. The equipment grounding conductor shall be neatly coiled and the coils tied together.
- (6) Welding of the anchor rods to the cage is unacceptable. Tie wires shall be used.



- (7) Bar steel reinforcement shall be coated with powdered epoxy resin in accordance with the WisDOT Standard Specifications for Highway and Structure Construction.
- (8) Any anchor rod projection shorter than 2 ¾" or longer than 3 ¼" shall require the base to be removed and replaced at the contractor's expense.
- (9) For Type 2 non-breakaway installations, contractor shall use a rodent screen.

910.3.4 Type 1 Modified Base

- (1) Type 1 modified base shall be constructed without conduit.

910.3.5 Type 10 Base

- (1) Bases shall be excavated by use of a circular auger.
- (2) Conduit sizes and locations shall be shown on the plans.
- (3) Conduit height above the concrete bases shall be 4 inches.
- (4) Contractor may pour concrete bases in two pours making sure to set and cover 1 foot above the bottom template during the first concrete pour.
- (5) A NO. 4 AWG, stranded copper equipment grounding conductor shall be exothermically welded to the Grounding Rod. The equipment grounding conductor shall be furnished and installed to enter the base, through a 3/4 inch conduit installed for grounding purposes, leaving a four (4) foot coil of wire above the concrete base. The equipment grounding conductor shall be neatly coiled and the coils tied together.
- (6) Welding of the anchor rods to the cage is unacceptable. Templates shall be used.
- (7) Bar steel reinforcement shall be coated with powdered epoxy resin in accordance with the WisDOT Standard Specifications for Highway and Structure Construction.

910.3.6 Type 13 Base

- (1) Use 3" clear for all reinforcement unless noted otherwise.
- (2) Welding of the anchor rods to the cage is unacceptable. Templates shall be used.
- (3) Bases (Shaft) below the wing, shall be excavated by the use of a circular auger.
- (4) Conduit size and locations shall be as shown on the plans.
- (5) Conduit height above the concrete bases shall be 4 ½" inches.
- (6) Contractor may pour concrete bases in two pours making sure to set and cover 1 foot above the bottom template during the first concrete pour.
- (7) A NO. 4 AWG, stranded copper equipment grounding conductor shall be exothermically welded to the Grounding Rod. The equipment grounding conductor shall be furnished and installed to enter the base, through a 3/4 inch conduit installed for grounding purposes, leaving a four (4) foot coil of wire above the concrete base. The equipment grounding conductor shall be neatly coiled and the coils tied together.
- (8) Bar steel reinforcement shall be coated with powdered epoxy resin in accordance with the WisDOT Standard Specifications for Highway and Structure Construction.

910.3.7 Type 10 Special Base

- (1) Bases shall be excavated by use of a circular auger.
- (2) Conduit sizes and locations shall be shown on the plans.
- (3) Conduit height above the concrete bases shall be 4 inches.
- (4) Contractor may pour concrete bases in two pours making sure to set and cover 1 foot above the bottom template during the first concrete pour.
- (5) A NO. 4 AWG, stranded copper equipment grounding conductor shall be exothermically welded to the Grounding Rod. The equipment grounding conductor shall be furnished and installed to enter the base, through a 3/4 inch conduit installed for grounding purposes, leaving a four (4) foot coil of wire above the concrete base. The equipment grounding conductor shall be neatly coiled and the coils tied together.
- (6) Welding of the anchor rods to the cage is unacceptable. Templates shall be used.



- (7) Bar steel reinforcement shall be coated with powdered epoxy resin in accordance with the WisDOT Standard Specifications for Highway and Structure Construction.

910.3.8 Signal Cabinet Base

- (1) Signal Cabinet Base shall be cast in place and shall conform to City of La Crosse Detailed Drawing.
- (2) Install four (4) ½" minimum diameter x 4" minimum length stainless steel approved concrete masonry anchors with a pullout strength of 9,000 lbs. to anchor the cabinet to base. The anchor studs shall be located as directed by the engineer to properly anchor the control cabinet to the base.
- (3) Maintenance platform shall be float or broom finished and be level. Maintenance platforms are not required when the cabinet opens onto a sidewalk.
- (4) Conduit exiting the concrete base (4 - 3" conduit) shall terminate in pull boxes as shown on the plans.
 - A. Small Base dimensions shall be 42" by 20.5" by 30" in depth and have a 42" by 36" by 1" deep maintenance platform on the door side of the cabinet.
 - B. Large Base dimensions shall be 3 feet by 4.5 feet, 2' 7" in depth, and have a 3 feet by 4.5 feet 1" deep maintenance platform on the door side of the cabinet.

910.4 Measurement

- (1) The department will measure Remove Concrete Base and Remove Signal Cabinet Base by a quantity of Each (EA).
- (2) The department will measure Type 1, 2, 10, 13, 10 Special, and 13 Special Base by a quantity of Each (EA).
- (3) The department will measure Signal Cabinet Base by a quantity of Each (EA).

910.5 Payment

The department will pay for the measured quantity at the contract unit price under the following bid item:

ITEM CODE	DESCRIPTION	UNIT
910.01	Remove Concrete Base (Type 1,2)	EA
910.02	Remove Concrete Base (Type 10, 13)	EA
910.03	Remove Signal Cabinet Base	EA
911.01-.02	Type 1 Base (type)	EA
911.03	Type 2 Base	EA
912.01	Type 10 Base	EA
912.02	Type 13 Base	EA
912.03	Type 10 Special Base	EA
913.01	Signal Cabinet Base (Small)	EA
913.02	Signal Cabinet Base (Large)	EA

910.6 Testing, Acceptance, & Maintenance

910.6.1 Underground Inspection

- (1) Contractor shall conform to Underground Inspection requirements in the City of La Crosse Standard Procedures.

910.6.2 Concrete Cylinders

- (1) Contractor shall prepare 3 cylinders according to AASHTO T23 and test the cylinders according to AASHTO T22.
- (2) If the strength of a cylinder is less than 90 percent of the required strength, the engineer will reject the resulting average. Contractor shall replace all concrete bases that fail the strength test at the contractors' expense before the base shall be accepted.
- (3) Contractor shall submit the compressive strength test results to the engineer for verification.



Engineering Department

400 La Crosse St., La Crosse, WI 54601 • (608) 789-7505 • Fax: (608) 789-8184
<http://www.cityoflacrosse.org>

910.6.3 Maintenance

- (1) Contractor shall protect all extruding bolts and conduits until the structure is installed.



915- SIGNAL CONDUIT

915.1 General Description

- (1) This section describes the installation of signal conduit within the project limits.

915.2 Materials

- (1) Furnish conduit consistent with the diameter bid item indicated in the plan. Backfilling materials shall conform to City of La Crosse Standard Procedures.
- (2) Unless otherwise directed by the Engineer, all conduit and accessories shall be unloaded at the point of delivery and hauled to and distributed at the site of the work by the Contractor. The materials shall be at all times handled with care to avoid damage. The material shall not be dropped or bumped against the ground, other pipe and accessories already on the ground, or any other object on the ground.
- (3) Unless otherwise specified, references to various standard specifications and test methods shall be understood to mean the specification or test method which is current on the date of awarding of bid.
- (4) Conduit shall be PVC electrical conduit conforming to UL 651. The Contractor shall use schedule 40 heavy wall type for enclosed locations. Schedule 80 extra-heavy wall type shall be used for locations exposed to the elements. Schedule 40 HDPE conforming to UL 651A may be used in lieu of Schedule 40 PVC for conduits installed by directional drilling.
 - A. Electrical conduit shall be standard gray color. Fiber conduit shall be same material but orange in color and a tracer wire included in the price.
- (5) Conduit and fittings shall be produced by the same manufacturer and be homogenous, virgin PVC C-300 compound free from visible cracks, holes or foreign inclusions. The conduit bore shall be smooth and free of blisters, nicks, or other imperfections which could mar conductors or cables.
- (6) Conduit and fittings shall be clearly marked with a UL label. The type and manufacturer shall be identified by legible and permanent markings.
- (7) All conduit and fittings shall be solvent welded in accordance with instructions from the manufacturer, and as directed by the Engineer. Solvent for welding PVC shall be clear, medium viscosity, with a fast set time, ASTM D 2564 or approved equal.
- (8) The pull wire shall be a No. 12 AWG, or larger size, copper wire and shall conform to the City of La Crosse Standard Procedures.

915.2.1 Tracer Wire

- (1) Any tracer wires shall be a single conductor, copper, XHHW insulated, USE rated and No. 12 A.W.G. and may be any color except Black, Red, Blue, White, or Green.

915.3 Construction Methods

915.3.1 Remove Conduit

- (1) Conduit shall be marked in the field by the engineer prior to start of work.
- (2) Any removals or damage caused beyond this point without the Engineer's permission will be the responsibility of the contractor to repair at their expense.

915.3.1 General Conduit Install

- (1) These items shall include any material and necessary tasks to excavate, install conduit and backfill, or directionally bore.
- (2) Natural backfill may be used in trenches and excavations which are not within 5' of or under pavement, driveways and sidewalks. Trenches under pavement, driveways and sidewalks shall have approved sand backfill placed in 6" layers over the conduit. The remainder of the trench shall be filled with ¾" Crushed Aggregate Base Course in 6"



Engineering Department

400 La Crosse St., La Crosse, WI 54601 • (608) 789-7505 • Fax: (608) 789-8184
<http://www.cityoflacrosse.org>

layers. Backfill material shall be mechanically compacted to a minimum of 95% of modified proctor. Trench backfill is considered incidental to the item of conduit.

- (3) All conduits shall be directionally bored where practicable, to minimize disturbances to existing pavement, curb and gutter, and sidewalk.
- (4) Each conduit run between access points to the wiring (e.g., handholes, pull boxes, poles) shall be one size for its entire length. Electrical conduit shall be installed within one (1) foot of the back of curb or as near as practical to the back of curb, as allowed by the Engineer, when it is being placed parallel to the curb. It will, however, be the responsibility of the Contractor to locate all underground conduit in a manner to preclude damage to the duct resulting from subsequent construction.
- (5) Conduit shall be of the nominal inside diameter as the plans show. The Contractor may substitute a larger size of conduit than that specified for a run; however, any resulting additional costs shall be borne by the Contractor and no adjustment in compensation will be made. All conduits shall be installed at a minimum depth of 30 inches below surface elevation. Conduits shall be connected using proper fittings and adhesives. Conduits shall be free of joints, splices, or connections preventing safe, snag-free, non-damaging pulling of wire throughout. All conduit ends shall be carefully reamed and/or bushings to protect the wires.
- (6) Standard conduit fittings shall be used and all costs for couplings and joints shall be included in the unit price bid for the conduit.
- (7) When connections are to be made to an existing conduit, the Contractor shall first verify that the existing conduit is fully clear and useable for its entire cross-section and length. When the existing conduit is found to be defective, the Contractor shall notify the Inspector and not proceed until the Inspector so directs. If the Contractor connects to an existing defective conduit without the express direction from the Inspector, the Contractor shall make any and all necessary repairs and replacements to all conduits, including conduit that was "existing" prior to the Contractor starting work. All costs of this work shall be at the expense of the Contractor.
- (8) A pull wire or tracer wire shall be installed in each conduit run in which cable will not be installed as part of the contract, including conduit connecting to existing conduit. The pull wire shall be approximately four (4) feet longer than the conduit run and shall be doubled back for at least two (2) feet at each terminal. Anchor the pull wire at each access point. The cost of pull wire shall be incidental to the cost of conduit unless specified otherwise in the Special Provisions.

915.3.2 Loop Detector Conduit Install

- (1) Loop detector install shall conform to WisDOT Standard Specifications for Highway and Structure Construction and WisDOT Standard Detail Drawing.
- (2) Loop size, configuration location, number of turns of wire and associated signal phase shall be as shown on the plans.
- (3) All loop detector conduit shall be placed in the base course a minimum of 3" below the new pavement.
- (4) Pitch lead out conduit to drain to roadside pull (splice) box.
- (5) Protection of the conduits in the base course shall be required after installation and before new pavement is installed.
- (6) Should installation repair be required, it shall be done under the direction of the engineer.

915.3.3 Connect to existing

- (1) Use 2-inch nonmetallic conduit, 3-inch nonmetallic conduit, and 2-inch HDPE conduit as provided and paid for under other items in this contract. Furnish backfill material, topsoil, fertilizer, seed, and mulch conforming to the standard spec.
- (2) Expose the outside of the existing structure without disturbing existing conduits or cabling. Drill the appropriately sized hole for entering conduits at a location within the structure without disturbing the existing cabling and without hindering the installation of new cabling within the installed conduit. Fill void area between the drilled



Engineering Department

400 La Crosse St., La Crosse, WI 54601 • (608) 789-7505 • Fax: (608) 789-8184
<http://www.cityoflacrosse.org>

hole and conduit with an engineer-approved filling material to protect against conduit movement and entry of fill material into the structure. Tamp backfill into place.

- (3) Contractor shall replace surface material per City of La Crosse Standard Specifications. These items shall be paid for under the individual surface material item.

915.4 Measurement

- (1) The department will measure Remove conduit by the linear foot (LF).
- (2) The department will measure each loop detector conduit or signal conduit by the linear foot (LF). HDPE installed in lieu of PVC shall be paid for under the same respective bid item as Signal Conduit (size).
- (3) The department will measure Connect to Existing by the unit (EA) acceptably installed.

915.5 Payment

The department will pay for the measured quantity at the contract unit price under the following bid item:

ITEM NUMBER	DESCRIPTION	UNIT
915	Remove Conduit	LF
916.01	Loop Detector Conduit (1")	LF
916.02	Signal Conduit (2")	LF
916.03	Signal Conduit (3")	LF
917	Connect to Existing	EA

915.6 Testing, Acceptance, & Maintenance

- (1) **At the request of the Engineer**, a mandrel at least six (6) inches in length and of the proper size shall be used during the inspection to ensure that the conduit is fully open for its entire length. The Contractor shall furnish all required tools, equipment and labor necessary to make the inspections. Any conduit found crushed or damaged, or determined by the Engineer to be unsatisfactory, shall be replaced by the Contractor at the Contractor's expense before the work will be accepted.

915.6.1 Underground Inspection

- (1) Contractor shall conform to Underground Inspection requirements in the City of La Crosse Standard Procedures.



920- PULL BOX AND COMMUNICATION VAULT

920.1 General Description

- (1) This section describes the removal, adjustment, or installation of a new pull box or communication vault.

920.2 Materials

- (1) Backfilling materials shall conform to City of La Crosse Standard Procedures.
- (2) Pull Box and Communication Vault material shall conform to WisDOT Standard Specifications for Highway and Structure Construction.
- (3) Conduits shall conform to City of La Crosse Standard Procedures.
- (4) Furnish manhole frames and solid lids conforming to AASHTO M105, class 30. Use locking covers in pavement roadway locations. Heavy duty frame and cover shall be stamped with "ELECTRIC". Pull box covers shall be one of the following grounded cast iron lids; Regular: R-5900-E, NF-0810 235; Locking: R-5900-E W/ Type G lock, NF-0810 235.

920.2.1 Steel Pull Box

- (1) Furnish steel pull boxes made of corrugated steel pipe conforming to AASHTO M36 with annular corrugations.
- (2) Grounding wire shall be 10 AWG with NEMA approved UL listed mechanical connector and approved for use with copper wire.

920.2.2 Non-conductive Pull Box

- (1) Non-conductive pull boxes must be made of non-conductive materials conforming to all the requirements of the current edition of ANSI/SCTE 77 (SCTE 77) "Specifications for Underground Enclosure Integrity" and with the modified impact requirements. The tier rating and modified impact requirements are listed below.
 - A. Impact: Any portion of the enclosure shall withstand a 70 ft-lb impact administered by a weight having a "B" tup per ASTM D2444 without puncturing, splitting or cracking. The test is to be conducted at a temperature of -30 degrees Fahrenheit. The cover is tested while placed on the enclosure.
 - B. Enclosure, extension, ring and cover shall have a minimum Tier 15 rating as specified in SCTE 77. Tier rating must be accomplished and results provided with all methods of adjustability being proposed.
- (2) Pull box covers Must be in compliance with the Public Rights of Way Accessibility Guidelines.
- (3) Pull box enclosures shall be comprised of the following components listed below. No individual component shall exceed 100 pounds in weight.
- (4) Main body with a depth of 36 or 42 inches, as specified in the plans, and must have minimum inside diameter of 24 inches. Must be field trim able for custom lengths. Must have an open bottom with 2 inch minimum continuous support foot and a maximum diameter of 33 inches.
- (5) Extension option of up to 12 inches. Must be field trim able for custom lengths. Cover must be round in shape, maximum diameter of 28 inches, require a tool to open and have no threaded fasteners. Cover shall be embossed in letters at least 3/4 inches high with "ELECTRIC" or as specified in the plans.
- (6) Cover support ring with a minimum opening diameter of 22 inches. Must be adjustable for slope corrections of up to 5%. Must be designed to bond to surrounding sidewalk and allow for uniform cover/pavement vertical movement of up to 6 inches.

920.2.3 Communications Vault

- (1) Communication Vault shall be one piece gray, polymer concrete rectangular.
- (2) Lid shall be a minimum of 22,500 lb. weight rating when used in boulevard or sidewalk areas. Vaults placed in driveways shall be rated to 33,7500 lb. The lid shall be stamped "FIBER" unless otherwise noted.
- (3) Vault sizes specified on the plans shall be 24 x 30 x 24 inches or 30 x 48 x 36 inches in size.



920.3 Construction Methods

920.3.1 Pull Box

- (1) Pull box installation shall conform to WisDOT Standard Detail Drawing.
- (2) Provide pull boxes with manhole frames and solid lids. The contractor may extend pull boxes as the plans show using the same material as the pull box. Saw extensions parallel to the annular ring and clamp to the pull box using a band manufactured for this purpose. Excavate, place coarse aggregate drain material, and backfill as the plans show. Dispose of surplus or unsuitable material as specified in City of La Crosse Standard Procedures.
- (3) All Frames and covers shall be heavy duty type, suitable for vehicular traffic loads.
- (4) Pull boxes located in the roadway shall have locking covers.
- (5) Entrance holes into pull boxes shall be cut with a circular hole saw or hydraulic conduit punch. Hole size shall be the outside diameter of the conduit that is to fit in the opening plus nor more than $\frac{1}{4}$ ". All conduit shall be pitched to drain to pull boxes.
- (6) Contractor shall not install wire in any pull box until its installation has been inspected and accepted by the engineer.
- (7) Grounding lug shall be installed per WisDOT Standard detail drawing.

920.3.2 Communication Vault

- (1) Provide additional conduit openings in vaults using a manufacturer-approved knockout punch driver. Ensure that gaps between the conduit and vault are not greater than 1/2 inch. Caulk gaps both on the inside and the outside of the vault. Cure caulk according to manufacturer's specifications before backfilling.
- (2) Install grounding rods with the vault.
- (3) All conduits entering the vault shall have bell ends on the end.
- (4) Install tracer wire marker posts so that they cannot be pulled out or removed manually. Install conduit into the access point and connect the tracer wire to the tracer wire marker post terminals.

920.3.3 Adjust and Remove Pull Box

- (8) Under the Adjusting Pull Boxes bid item, move existing pull boxes to grade level. Excavate, adjust subsurface components as required, and backfill as the plan details show. Dispose of surplus or unsuitable material offsite.
- (9) Under the Removing Pull Boxes bid item, excavate and remove existing pull boxes. Backfill with material similar to the surrounding material. Dispose of surplus or unsuitable material offsite.

920.4 Measurement

- (1) The department will measure these items by a quantity of Each (EA).

920.5 Payment

The department will pay for the measured quantity at the contract unit price under the following bid item:

ITEM NUMBER	DESCRIPTION	UNIT
920	Remove Pull Box	EA
921.01-.02	New Pull Box (type)	EA
922.01-.02	Communications Vault (type)	EA
923.01-.02	Adjust Pull Box (type)	EA

920.6 Testing, Acceptance, & Maintenance

920.6.1 Underground Inspection

- (1) Contractor shall conform to Underground Inspection requirements in the City of La Crosse Standard Procedures.



925- SIGNAL WIRING

925.1 General Description

- (1) This section describes the installation of signal wiring within the project limits.

925.2 Materials

- (1) Contractor shall submit a complete list of signal components and hardware after awarding of the bid to the engineer.

925.2.1 Loop Detector Lead-in Cable

- (1) Furnish shielded, 14 AWG, 2 conductor, polyethylene insulated, with 16 AWG drain wire, conforming to IMSA Specification Number 50-2 for loop detector lead-in cable.

925.2.2 Loop Detector Wire

- (1) Furnish black 12 AWG, XLP insulated, USE rated, single conductor, stranded copper wire with 7 or more strands for loop detector wire.

925.2.3 Signal Cable

- (1) Furnish solid copper conductor traffic signal cables conforming to IMSA Specification Number 20-1. Provide wire size and number of conductors as the plans show.
- (2) Wire sheathing must be a solid color. Colored tape will not be acceptable.
- (3) For wiring that extends from the terminal strip in each signal head to the mounting base, use an IMSA, 20-1 cable, 14 AWG 4, 5, or 7 conductor as required.

925.2.4 Lighting Cable UF 2-12 AWG

- (1) Cable shall be type UF cable with ground conforming to ANSI/UL 493. Provide cable with 2-12 AWG as defined.

925.2.5 Electrical Wire 10 AWG

- (1) Cable shall be solid copper conductor cable conforming to IMSA Specification Number 20-1. Provide cable with 10 AWG as defined.

925.2.6 Grounding Cable

- (1) Use green insulation or green insulation with a yellow tracer applied by thermoset method.
- (2) Grounding conductor wire shall be Underground Service Entrance (USE) designated.

925.2.7 Emergency Vehicle Preemption Cable

- (1) Furnish 3-conductor shielded, 600 volt, type B control cable conforming to IPCEA-5-61-402/NEMA WC5 with a foil shield, 20 AWG stranded conductors and ground wire, and rated for 75 degrees C. Ensure that the conductors are color coded with 1 blue, 1 orange, and 1 yellow conductor.

925.2.8 Camera Cable

- (1) Furnish cables and connectors required to transmit video and camera control data between the camera assembly and the camera controller assembly. Conform to the following:
 - A. Outdoor rated category 5e, or better, UTP cable with water-blocking flooded core and UV-resistant polyethylene jacket. Furnish cable consisting of 4-pairs of 24 AWG solid copper conductors and according to ANSI/TIA/EIA 568A Category 5e, CENELEC EN50173, ICEA S-90-661, and ISO/IEC 11801.
 - B. Outdoor rated CSA, certified for outdoor use, 3-conductor 16 AWG power, UL listed cable in a UV resistant jacket. Furnish MSHA approved and RoHS compliant cable according to CSA flexible cord - C22.2-49.

925.3 Construction Methods

925.3.1 General Installation

- (1) Perform work in accordance with the provisions of WisDOT Standard Specifications for Highway and Structure Construction except as hereinafter modified.



- (2) Contractor shall follow City of La Crosse Standard Procedures and receive written approval from the engineer prior to installing any cable.
- (3) Connect all ungrounded conductors with wire nuts in the appropriate sections of the signal heads. Connect the neutral conductors to the terminal strip. Be certain to twist wires prior to installing the wire nuts. All wire nuts must be installed facing up to prevent the entrance of water.
- (4) Under no circumstances shall cable ends be left uncovered or allowed to become submerged in water.
- (5) For cables entering each pull box, except as noted below or for loop detector lead in cables, provide an extra loop, approximately 16 feet long, to remain in each pull box. This loop of cable is in addition to the quantity needed to reach from the entrance conduit raceway end to the opening in the exiting conduit raceway.
- (6) The contractor shall supply the Engineer with a final wiring diagram showing each conductor route, and the conductors used for each signal face or pedestrian button.
- (7) Tag traffic signal cables, loop lead in cables, emergency vehicle preemption cables, and camera cables terminating in the signal control cabinet with waterproof tape and mark with indelible ink. Ensure markings indicate the geographical location, phase direction, and/or loop detector number.
- (8) The contractor shall submit two copies to the project engineer of the Detection wiring diagrams, cable and routing diagrams, pole to pull box wiring diagrams, conductor layout standards and the associated head arrangements and other pertinent details.

925.3.2 Loop Detector Lead-in

- (1) The contractor shall conform to WisDOT Standard Specifications for Highway and Structure Construction except as described below.
- (2) Do not provide extra length of loop lead in cable in pull boxes. For each loop, use a separate lead in cable to the control cabinet.
- (3) Splice cables using cast in place splice kits from an approved manufacturer. Make splices as soon as possible after installing loop detector lead in cable.
- (4) Identify loop detector lead-in wire with waterproof tape and mark with indelible ink.
- (5) After splicing the loop wire to the loop lead in cable, measure inductance, ground resistance and wire resistance at the cabinet end of the lead in cable. Furnish a copy of the readings to the engineer for evaluation.

925.3.3 Loop Detector wire

- (1) The contractor shall conform to WisDOT Standard Specifications for Highway and Structure Construction except as described below.
- (2) Do not provide extra length of loop detector wire in the pull box.
- (3) Install the loop wire from the pull box at the side of the road, around the loop in the number of turns shown in the plans, and back to the pull box at the side of the road, in one continuous non-spliced length.
- (4) Measure the loop inductance, ground resistance, and loop wire resistance at the pull box end of the loop wire immediately after installation. Furnish a copy of the readings to the engineer for evaluation.

925.3.4 Signal Cable

- (1) The contractor shall conform to WisDOT Standard Specifications for Highway and Structure Construction except as described below.
- (2) When pulling cable into or out of pull boxes, the Contractor shall use pulleys. The Contractor shall at all times exercise caution to protect the cable and its insulation from being damaged by sharp edges. Cable shall project at least two (2) feet above bases, except at the signal cabinet, where it shall project at least three (3) feet above the base.
- (3) Group and identify sets of conductors in signal cables, per signal phase, at each pertinent termination.
- (4) Ensure the grounded conductor in feeder cables is 12 inches longer than the ungrounded conductors. Also ensure that the pole cable from the signal heads to the signal base extends 24 inches beyond the access door.



- (5) Effectively ground spare or unused conductors in the signal control cabinet to the equipment grounding terminal strip.
- (6) Make electrical connections in the traffic signal base with spring wound wire nuts, insulated with a soft flexible covering or as detailed on the plans. Extend wire for termination 18 inches beyond the pole or traffic signal standard access point. Provide 60 inches of cable wire to be pulled into cabinets and left for terminations.
- (7) If mounting more than one signal head on a standard pole, wire each head with a separate cable from the mounting base to the appropriate terminal strips.
- (8) Push buttons shall utilize signal cable color defined in the plans. Contractor may use loop detector wire at no additional cost to the City.
- (9) Cable shall be installed in continuous lengths without splices from terminal to terminal. Splicing of cables will be permitted only in pull boxes, handholes in poles, pole bases, or as otherwise provided in the plans.

925.3.6 Signal Lighting Cable

- (1) Cable shall be installed in continuous lengths without splices from terminal to terminal. Splicing of cables will be permitted only in pull boxes, handholes in poles, pole bases, or as otherwise provided in the plans.
- (2) Lighting wiring shall be installed with two circuits extending from each direction from the signal cabinet.

925.3.7 Cable Routing

- (1) Conductors shall be assigned to conform with City Standard color assignment. Cabling Chart in the plan shall be followed.
- (2) Typical assignment is as follows for color assignment: Assign primary/secondary colors by phase then by movement.
 - A. Assign Primary colors to Phase 6, 1, 4 and 7. RED, ORG, GRN
 - B. Assign secondary colors to Phase 2, 5, 8, and 3 when Primary phase is on same pole. RED/BLK, ORG/BLK, GRN/BLK
 - C. Walk =BLU
 - D. Don't Walk =BLK
 - E. Ped Button =WHT/BLK

925.3.8 Emergency Vehicle Preemption Cable

- (1) The contractor shall conform to WisDOT Standard Specifications for Highway and Structure Construction except as described below.
- (2) Contractor shall provide the EVP cable and mount City furnished brackets.
- (3) The engineer will determine the exact location to ensure that the installation does not create a sight obstruction.
- (4) Ensure that the cable runs continuously without splicing from the pull box closest to the cabinet including the specified extra cable. Do not splice EVP cable from the detector assembly to the controller terminations. Provide 8.5 feet of extra cable at the mounting bracket with 6 feet at the bracket and 2.5 feet extending out of the mounting bracket. Provide 6 feet of extra cable in each pull box plus an additional 20 feet at the nearest pull box to signal base where the EVP detector head is to be mounted.
- (5) Identify EVP Cable with waterproof tape and mark with indelible ink.

925.3.9 Camera Cable

- (1) The contractor shall conform to WisDOT Standard Specifications for Highway and Structure Construction except as described below.
- (2) Provide camera cables in conduit and poles as the plans show. Provide continuous cable runs without splices between the camera assembly and the camera controller assembly.
- (3) Take every precaution to ensure that the cable is not damaged during storage or installation. Workmen should not step on cable or run over by any vehicle or equipment. Do not pull the cable along the ground or over or around obstructions.



Engineering Department

400 La Crosse St., La Crosse, WI 54601 • (608) 789-7505 • Fax: (608) 789-8184
<http://www.cityoflacrosse.org>

- (4) Keep cable ends sealed at all times during installation using a cable end cap from an approved manufacturer. Do not use tape to seal the cable end. Keep the cable end sealed until connectors are installed.
- (5) Do not exceed the minimum-bending radius of the cable at any time.
- (6) Provide 6 feet of cable slack within cabinets.
- (7) Make all camera cable connections among the camera, camera power source, ethernet switch, and other associated devices.

925.4 Measurement

- (1) The department will measure each linear foot (LF) of item successfully installed, including extra coils of wire in pull boxes, bases, and cabinet as defined above.

925.5 Payment

The department will pay for the measured quantity at the contract unit price under the following bid item:

ITEM NUMBER	DESCRIPTION	UNIT
925.01	Loop Detector (lead-in)	LF
925.02	Loop Detector (wire)	LF
926.01-.04	Signal Wiring (Conductor Number)	LF
926.05-.06	Signal Lighting Cable (Type)	LF
926.07	Emergency Vehicle Preemption Cable	LF
926.08	Camera Cable	LF

925.6 Testing, Acceptance, & Maintenance

925.6.1 Underground Inspection

- (1) Contractor shall conform to Underground Inspection requirements in the City of La Crosse Standard Procedures.

925.6.2 Aboveground Inspection

- (1) Contractor shall conform to Aboveground Inspection requirements in the City of La Crosse Standard Procedures.

925.6.3 Loop Detector Inductance

- (1) Measure the loop inductance, ground resistance, and loop wire resistance at the pull box end of the loop wire immediately after installation. Furnish a copy of the readings to the engineer for evaluation.
- (2) Measure ground resistance using a megger. Replace loop wire not attaining greater than 500 mega ohms to ground.

925.6.4 Camera Cable Continuity

- (1) Perform continuity tests on the coax element of the camera cable using a metallic time domain reflectometer (MTDR) with chart recorder. Camera cable shall not exhibit any discontinuities such as opens, shorts, crimps, or defects.
- (2) Use a purpose built "Pass-Fail" network cable tester to test the network cable installation for category 5, class E compliance. Repair connections or cable as needed for the test to register a "Pass".
- (3) Measure the insulation resistance between conductors, and between each conductor, ground, and shielding using a megger. Ensure that the resistance is greater than 500 mega ohms.
- (4) Should any cable fail to meet the test parameters, or should any testing reveal defects in the cable, replace the cable at no expense to the department. Retest the new cable as specified above.



930- SIGNAL POLES, ARMS, STANDARDS

930.1 General Description

- (1) This section describes the furnishing, assembling, and installing of Traffic Signal Poles within the project limits.

930.2 Materials

930.2.1 General Materials

- (1) Signal Bases and anchor bolts shall conform to City of La Crosse Standard Procedures.
- (2) Signal Cable shall conform to City of La Crosse Standard Procedures.
- (3) Signal Specialty equipment shall conform to City of La Crosse Standard Procedures.
- (4) Signal heads, pedestrian heads, pedestrian buttons, signal housing, luminaires, and mounting hardware shall conform to City of La Crosse Standard Procedures.
- (5) Signal poles, arms, standards, and base material shall conform to WisDOT Standard Specifications for Highway and Structure Construction except as modified below.
- (6) Contractor shall submit a complete list of signal components and hardware after awarding of the bid to the engineer.

930.2.2 Signal Standards

- (1) Contractor shall furnish signal standards consisting of extruded seamless aluminum alloy 6061-T6 manufactured conforming to ASTM B241, or porthole extruded aluminum alloy 6061-T6 manufactured conforming to ASTM B429.
- (2) Ensure that the manufacturer has indent printed the ASTM and alloy designations 2 inches above the threading on the outside of each standard using 1/4-inch dies.

930.2.3 Transformer & Pedestal Base

- (1) Contractor shall furnish all cast aluminum alloy pedestal and transformer bases meeting the AASHTO Standard Specification for Structural Supports for Highway Signs, Luminaires, and Traffic Signals as published in the 1994, Third Edition.
- (2) Ensure the castings are true to pattern in form and dimensions and free from defects affecting strength or service life. Thread casting collars for pedestal bases to mate with the traffic signal standards. Use mounting washers for transformer bases conforming to the manufacturer's instructions.

930.2.4 Type 2 and Type 3 Pole

- (1) Contractor shall furnish Type 2 and Type 3 poles, and shall conform to AASHTO Standard Specification for Structural Supports for Highway Signs, Luminaires, and Traffic Signals as published in the 1994, Third Edition.

930.2.5 Trombone Arm

- (1) Contractor shall furnish trombone arms and aluminum luminaire arms, and shall conform to AASHTO Standard Specification for Structural Supports for Highway Signs, Luminaires, and Traffic Signals as published in the 1994, Third Edition.

930.2.6 Type 9, 10, 12, 13, 9 Special, and 10 Special Pole

- (1) Contractor shall furnish steel monotube poles, zinc coated according to ASTM A123. Contractor shall furnish all required bolts, fasteners, or other necessary appurtenances necessary for a complete assembly.

930.2.7 Monotube Arm

- (1) Contractor shall furnish steel monotube arms and steel luminaire arms, zinc coated according to ASTM A123.

930.2.8 Luminaire Arm

- (1) Aluminum Arms:
 - A. Contractor shall furnish aluminum luminaire arms, and shall conform to AASHTO Standard Specification for Structural Supports for Highway Signs, Luminaires, and Traffic Signals as published in the 1994, Third Edition.



- B. Make luminaire arms out of extruded aluminum. Ensure that the arms are clean with a uniform natural aluminum finish. Do not paint or apply other anti-corrosion coatings.
- C. Furnish an extruded aluminum fixture welded to the pole end of the luminaire arm that allows the arm to be clamped to a round pole dimensioned as the plans show. Furnish mounting clamps with stainless steel bolts, nuts, and washers conforming to ASTM A320.

920.2.9 High-Strength Steel Bolts

- (1) Furnish zinc-coated type 1 bolt/nut/washer assemblies for field tensioning conforming to WisDOT Standard Specifications for Highway and Structure Construction.

930.2.10 Black Color

- (1) Aluminum Poles, Standards, luminaires, and Arms: Poles, Standards, and Arms shall be factory anodized and painted black so as to produce a uniform appearance. Nut covers and pole caps shall be finished to match pole.
- (2) Steel poles, luminaires, and arms: Poles and arms shall be factory powder coated enamel finish so as to produce a uniform appearance.
- (3) Transformer and Pedestal Bases: Shall be anodized and painted black. The black finish shall be applied to match the color/finish of the pole.

930.3 Construction Methods

930.3.1 Removal

- (1) Removals are shown on plans and/or by field markings done by Engineer. Any removals or damage caused beyond this point without the Engineer's permission will be the responsibility of the contractor to repair at their expense.
- (2) All above ground traffic signal equipment and material noted on the plans to be removed shall be salvaged and set aside in an easily accessible area or delivered to City of La Crosse Street Department.
- (3) The Contractor shall remove street light pole (poles, arms, metal base, and fixtures) and traffic signal pole (including metal base and other attachments) as identified on the plan or by the Engineer.
- (4) All street light poles, metal base, arms, fixtures, traffic signal poles, traffic signal cabinets, and all handhole and electrical utility access structure frames and covers removed by the Contractor, shall be salvaged and delivered to the Municipal Storage Unit, unless designated by the Engineer to be reinstalled in the project area or not returned to the City.
- (5) Care shall be taken as to not damage signal heads, LEDs, video, EVP, or radio equipment.
- (6) Pole and arm shall be disassembled for ease of transportation.
- (7) The Contractor shall be responsible for protecting all equipment and materials from damage during removal, salvaging, and delivery. This shall be considered incidental to the removal bid items.

930.3.2 General Construction

- (1) Signal poles, arms, standards, and base construction methods shall conform to WisDOT Standard Specifications for Highway and Structure Construction except as modified below.
- (2) After signal poles, arms, and luminaires have been installed, contractor shall attach all signal heads, pedestrian heads, luminaires, pedestrian buttons conforming to City of La Crosse Standard Procedures. These items shall be included in signal pole assemblies.
- (3) Contractor shall install specialty equipment conforming to City of La Crosse Standard Procedures. These install items shall be measured and paid for under separate items.
- (4) Clean each pole before installation.
- (5) After completing erection using normal pole shaft raking techniques, ensure the centerline of the shaft appears vertical.



930.3.3 Salvage Signal Equipment

- (1) Arrange for an inspection of all traffic signal equipment by representatives from the City of La Crosse engineer a minimum of five business days prior to removal. This inspection is intended to provide an inventory and assessment of the original condition of the equipment and to determine what equipment the City of La Crosse would like to retain.
- (2) Arrange for the de-energizing of the traffic signals and removal of existing electrical service with the local electrical utility after receiving approval from the engineer that the existing traffic signals can be removed.
- (3) All above ground traffic signal equipment and material noted on the plans to be removed shall be disconnected, disassembled, removed, and set aside in an easily accessible area or delivered to City of La Crosse Street Department.
- (4) Care shall be taken as to not damage signal heads, LEDs, video, EVP, or radio equipment. Replace any traffic signal equipment to be salvaged that is damaged in the removal process with equipment that is of equal quality to that of the damaged piece.
- (5) The Contractor shall be responsible for protecting all equipment and materials from damage during removal, salvaging, and delivery. This shall be considered incidental to the removal bid items.

930.3.4 Signal Standard Assembly

- (1) Construction of signal standards shall include furnishing, assembling, and installing all pedestal base, pole, signal heads, signal housing, mounting hardware, and/or push buttons as designated on the signal plan.
- (2) Thread traffic signal standards into their pedestal bases without damaging the threads. Ensure that the base is level on its concrete foundation and the standard is vertical after all connections are tight.

930.3.5 Aluminum pole, arm, luminaire assembly

- (1) Construction of signal pole type 2 and 3 shall include furnishing, assembling, and installing all transformer base, pole, trombone arm, luminaire arm, signal heads, signal housing, mounting hardware, luminaire, and/or push buttons as designated on the signal plan.

930.3.6 Monotube pole, arm, luminaire assembly

- (1) Construction of signal pole type 9, 10, 12, 13, 9 Special, and 10 Special shall include transporting, assembling, and installing monotube pole, monotube arm, steel luminaire arm. Contractor shall furnish and install all signal heads, signal housing, mounting hardware, luminaire, and/or push buttons as designated on the signal plan.
- (2) Install poles as specified in the plan details. Secure pole to anchor assembly and document tensioning procedures conforming to WisDOT form DT2321 and DT2322.
- (3) Install traffic signal heads within 5 days after monotube arms are erected to control vibration.

930.3.7 RRFB assembly

- (1) City of La Crosse shall provide RRFB assembly. Contractor shall schedule a pick-up time 5 business days in advance of material pick up from the municipal storage unit.
- (2) Construction of RRFB shall include furnishing, assembling, and installing all pedestal base, pole, and/or push buttons as designated on the signal plan.
- (3) Contractor shall attach RRFB sign assembly according to manufacturer specification.
- (4) Thread traffic signal standards into their pedestal bases without damaging the threads. Ensure that the base is level on its concrete foundation and the standard is vertical after all connections are tight.

930.3.8 Black pole

- (1) Components when assembled shall appear as one uniformly colored unit. Touch up paint shall be furnished and applied by the Contractor to all scratches and construction blemishes as to match the original black factory color and finish.



930.4 Measurement

- (1) Remove Traffic Signal should be measured by pole or by intersection as a quantity of each (EA) as specified in the plans.
- (2) The department will measure signal poles as each (EA) pole successfully installed.

930.5 Payment

The department will pay for the measured quantity at the contract unit price under the following bid item:

ITEM NUMBER	DESCRIPTION	UNIT
930.01	Remove Traffic Signal (intersection)	EA
930.02	Remove Traffic Signal (pole)	EA
931.01-.06	Standard Pole (color, size)	EA
932.01-.08	Type 2 Pole (color, arm length)	EA
933.01-.16	Type 3 Pole (color, arm, luminaire length)	EA
934.01-.06	Type 4 Pole (color, luminaire length)	EA
935.01-.08	Type 9 Pole (color, arm length)	EA
935.09-.14	Type 9 Special Pole (color, arm, length)	EA
936.01-.16	Type 10 Pole (color, arm, luminaire length)	EA
936.17-.28	Type 10 Special Pole (color, arm, luminaire length)	EA
937.01-.10	Type 12 Pole (color, arm length)	EA
938.01-.20	Type 13 Pole (color, arm, luminaire length)	EA

930.6 Testing, Acceptance, & Maintenance

930.6.1 High-strength Bolt testing

- (1) Pre-installation Testing
 - A. Notify the engineer before performing the required field pre-installation testing.
 - B. Lubricate high-strength bolt threads with a wax-based lubricant before testing. Test bolt/nut/washer assemblies with DTIs in all the configurations used for installation.
 - C. Perform pre-installation testing in the field conforming to the procedures enumerated in department form DT2322 for each bolt/nut/washer/DTI size and configuration installed. Provide the engineer with the test results by submitting 2 copies of WisDOT form DT2322.
- (2) Installation Testing
 - A. Do not begin bolt installation without the engineer's approval.
 - B. Lubricate high-strength bolt threads with a wax-based lubricant before installation.
 - C. Tension high-strength bolts using DTIs. Install the DTI on the bolt with the protrusions facing away from the connected materials. Install bolt/nut/washer assemblies with DTIs in the same configuration used for pre-installation testing.
 - D. Tighten conforming to WisDOT form DT2322 to provide the correct installation tension within 48 hours after arm installation. If not fully tensioned within 48 hours, provide new bolt/nut/washer assemblies with new DTIs and fully tension immediately. During the operation, ensure no rotation of the part not turned by the wrench. Snug systematically from the most rigid part of the connection to the free edges. Repeat until the full connection is in a snug condition and the faying surfaces are in firm contact. Systematically tighten the connection required number of refusals is achieved. If the gaps on the DTI are completely closed, discontinue tightening.



Engineering Department

400 La Crosse St., La Crosse, WI 54601 • (608) 789-7505 • Fax: (608) 789-8184
<http://www.cityoflacrosse.org>

- E. The engineer may verify bolt installation by periodically testing with a feeler gauge.
 - (3) Contractor shall provide completed WisDOT form DT2322 for each monotube arm length.
- 930.6.2 Aboveground Inspection**
- (1) Contractor shall conform to Aboveground Inspection requirements in the City of La Crosse Standard Procedures.



940- SIGNAL HEADS

940.1 General Description

- (1) This section describes the furnishing, assembling, and installing of Traffic Signal Heads within the project limits.

940.2 Materials

- (1) Contractor shall submit a complete list of signal components and hardware after awarding of the bid to the engineer.
- (2) Materials shall conform to WisDOT Standard Specifications for Highway and Structure Construction except as modified below.
- (3) If requested in the plan, signal housing and mounting hardware shall be black.

940.2.1 Signal Heads

- (1) Contractor shall furnish signal housings, visors, LED modules, backplates, and cut away or tunnel type visors as the plans show. Signal heads shall be 12" Dialight LED lens, with Mobotrex 12" signal head housing as the plans show. Signal housing shall be black in color if pole is black.

940.2.2 Pedestrian Heads

- (1) Contractor shall furnish pedestrian signal housings, LED module's, and visors, and a z-crate visor as the plans show. Pedestrian heads shall be 16" Countdown timers by Dialight, with Mobotrex 16" pedestrian housing and a z-crate visor. Pedestrian housing shall be black in color if pole is black.

940.2.3 Pushbutton

- (1) Contractor shall furnish a standard R 10-3e series sign. Include directional arrows on the sign as the plans show. Contractor shall furnish accessible pedestrian signal with push buttons that meets PROWAG requirements with both audible and vibrotactile formats. Push button unit shall be black if pole is black.

940.2.4 Mounting Hardware

- (1) Contractor shall furnish weather tight mounting hardware. Protect mounting hardware from the elements before installation. Use corrosion resistant poly bracket shims.

940.2.5 RRFB System

- (1) City of La Crosse shall furnish Rectangular Rapid Flashing Beacon (RRFB) system. Contractor shall schedule a pick-up time 5 business days in advance of material pick up from the municipal storage unit. Contractor shall furnish pole, base, mounting hardware, and pushbutton.
- (2) RRFB System Includes blinkerbeam radio transmitter, solar power panel, Sign, and RRFB light bar.

940.3 Construction Methods

- (1) Contractor shall conform to WisDOT Standard Specifications for Highway and Structure Construction for construction methods.

940.3.1 Salvage Signal Heads

- (1) Arrange for an inspection of all traffic signal equipment by representatives from the City of La Crosse engineer a minimum of five business days prior to removal. This inspection is intended to provide an inventory and assessment of the original condition of the equipment and to determine what equipment the City of La Crosse would like to retain.
- (2) Arrange for the de-energizing of the traffic signals and removal of existing electrical service with the local electrical utility after receiving approval from the engineer that the existing traffic signals can be removed.
- (3) All above ground traffic signal equipment and material noted on the plans to be removed shall be disconnected, disassembled, removed, and set aside in an easily accessible area or delivered to City of La Crosse Street Department.



Engineering Department

400 La Crosse St., La Crosse, WI 54601 • (608) 789-7505 • Fax: (608) 789-8184
<http://www.cityoflacrosse.org>

- (4) Care shall be taken as to not damage signal heads, LEDs, video, EVP, or radio equipment. Replace any traffic signal equipment to be salvaged that is damaged in the removal process with equipment that is of equal quality to that of the damaged piece.
- (5) The Contractor shall be responsible for protecting all equipment and materials from damage during removal, salvaging, and delivery. This shall be considered incidental to the removal bid items.

940.4 Testing, Acceptance, & Maintenance

940.4.1 Aboveground Inspection

- (1) Contractor shall conform to Aboveground Inspection requirements in the City of La Crosse Standard Procedures.



945- SIGNAL CABINET EQUIPMENT

945.1 General Description

- (1) This section describes the transport and installation of a signal cabinet within the project limits.

945.2 Materials

945.2.1 Signal Cabinet

- (1) City of La Crosse shall furnish traffic signal controller and the traffic signal cabinet. Contractor shall schedule a pick-up time 5 business days in advance of material pick up from the municipal storage unit.
- (2) Contractor shall furnish other needed materials in conformance with WisDOT Standard Specifications for Highway and Structure Construction.

945.2.2 Electrical Meter

- (1) Electrical Meter Pedestal Service shall conform to WisDOT Standard Specifications for Highway and Structure Construction.
- (2) Contractor shall furnish conduit fittings, grounding electrodes, and connections and necessary conductors and equipment required to provide power to the cabinet.

945.2.3 Black Paint

- (1) If noted in the signal plan, cabinet shall be factory black powder coat finished so as to produce a uniform appearance.

945.3 Construction Methods

945.3.1 Salvage / Remove Signal Cabinet

- (1) Arrange for an inspection of traffic signal cabinet by representatives from the City of La Crosse a minimum of five business days prior to removal. This inspection is intended to provide an inventory and assessment of the original condition of the equipment and to determine what equipment the City of La Crosse would like to retain.
- (2) Arrange for the de-energizing of the traffic signal cabinet and removal of existing electrical service with the local electrical utility after receiving approval from the engineer that the existing traffic signal cabinet can be removed.
- (3) Signal cabinet components are to be removed and secured in a box prior to detaching the cabinet from the base. Signal cabinet and its components shall be delivered to City of La Crosse Street Department.
- (4) Care shall be taken as to not damage remaining signal equipment. Replace any traffic signal equipment to be salvaged that is damaged in the removal process with equipment that is of equal quality to that of the damaged piece.
- (5) The Contractor shall be responsible for protecting all equipment and materials from damage during removal, salvaging, and delivery. This shall be considered incidental to the removal bid items.

945.3.2 Signal Cabinet

- (1) Construction of signal cabinet shall include transporting, assembling, and installing signal cabinet as designated by the engineer. Contractor shall use care in transporting signal cabinet components as to not damage electrical components.
- (2) Install the field cabinet on a new or existing concrete base paid separately. Prior to installation of signal cabinet, all wire shall be tested and verified by engineer or electrician. Make all power connections to the cabinet, isolating the neutral bus from the cabinet and equipment ground. Effectively ground all cable grounding shields and any spare or unused conductors in the cabinet to the equipment grounding terminal strip. Contractor shall provide signal-turn-on checklist and City of La Crosse engineer or electrician shall be onsite for signal cabinet installation.
- (3) Coordinate directly with the department's traffic signal cabinet vendor {TAPCO at (262) 814-7327 or rickett@tapconet.com / TCC at 651-439-1737 or mallwood@trafficcontrolcorp.com} to schedule the cabinet



Engineering Department

400 La Crosse St., La Crosse, WI 54601 • (608) 789-7505 • Fax: (608) 789-8184
<http://www.cityoflacrosse.org>

acceptance testing. Coordinate with the City electrician to participate in the acceptance testing. The City has final determination of the cabinet acceptance testing date and time. After the contractor has mounted the cabinet on the cabinet foundation, he shall connect all the field wiring inside the controller cabinet and test the signal circuits for correct operation. The contractor shall connect and test the signal circuits outside the controller cabinet as directed by the engineer. Connecting and testing signal circuits shall be considered part of this item of work.

- (4) Terminal strips shall be used to terminate controller cable, signal head cables and vehicle and pedestrian detector cables. All controller inputs and outputs shall be terminated on an interface panel. All interface and output terminal connections shall be the screw down type.

945.3.3 Electrical Meter

- (1) Install the electrical service conforming to Xcel Energy requirements. Furnish Xcel Energy with a wiring affidavit, certifying that the service was installed conforming to the WSEC. The City will be responsible for any charges from Xcel Energy service installation or relocation and energy cost will be billed to and paid for by the City.
- (2) Install the cabinet base and meter breaker pedestal first, so the electrical utility company can install the service lateral. Finish grade the service trench, replace topsoil that is lost or contaminated with other materials.

945.3.4 Black Paint

- (1) Touch up paint shall be furnished and applied by the Contractor to all scratches and construction blemishes as to match the original black factory color and finish.

945.4 Measurement

- (1) The department will measure Remove Traffic Signal Cabinet by a quantity of Each (EA).
- (2) The department will measure Transport and Install Signal Cabinet as a lump sum (LS) unit successfully completed.
- (3) The department will measure Install Electrical Meter Pedestal Service as each (EA) successfully completed.

945.5 Payment

The department will pay for the measured quantity at the contract unit price under the following bid item:

ITEM NUMBER	DESCRIPTION	UNIT
945	Remove Traffic Signal Cabinet	EA
946.01-.02	Transport and Install Signal Cabinet (color, Small)	LS
946.03-.04	Transport and Install Signal Cabinet (color, Large)	LS
947	Install Electrical Meter Pedestal Service	EA

945.6 Testing, Acceptance, & Maintenance

- (1) Contractor shall inform the City when Signal Cabinet components are ready for inspection. The City Inspector or Engineer shall review all signal cabinet installations three (3) business days after inspection request from the contractor. Contractor may inspect signal cabinet installations with the Inspector or Engineer.
- (2) Contractor shall use "Signal Turn-on Form" and shall submit form to engineer.
- (3) Operate the completed traffic signal installation for 72 hours consecutively, using the specified signal sequence and all special functions, such as preemption, as the plans show, or as the engineer approves.
- (4) The traffic signal installation is not complete until the electrical work is complete and electrical systems work properly.



950- SIGNAL SPECIALTY EQUIPMENT

950.1 General Description

- (1) This section describes the installation of specialty signal equipment within the project limits.

950.2 Materials

- (1) City of La Crosse shall provide all necessary mounting hardware and specialty equipment. Contractor shall schedule a pick-up time 5 business days in advance of material pick up from the municipal storage unit.

950.2.1 Video Cable

- (1) Furnish cables and connectors required to transmit video and camera control data between the camera assembly and the camera controller assembly. Camera cable shall conform to City of La Crosse Standard Procedures.

950.2.2 Emergency Vehicle Preemption Cable

- (1) Furnish EVP Cable and connectors conforming to the City of La Crosse Standard Procedures.

950.3 Construction Methods

950.3.1 Salvage Specialty Signal Equipment

- (1) Arrange for an inspection of all traffic signal equipment by representatives from the City of La Crosse engineer a minimum of five business days prior to removal. This inspection is intended to provide an inventory and assessment of the original condition of the equipment and to determine what equipment the City of La Crosse would like to retain.
- (2) All above ground traffic signal equipment and material noted on the plans to be salvaged shall be disconnected, disassembled, removed, and set aside in an easily accessible area or delivered to City of La Crosse Street Department.
- (3) Care shall be taken as to not damage signal heads, LEDs, video, EVP, or radio equipment. Replace any traffic signal equipment to be salvaged that is damaged in the removal process with equipment that is of equal quality to that of the damaged piece.
- (4) The Contractor shall be responsible for protecting all equipment and materials from damage during removal, salvaging, and delivery. This shall be considered incidental to the removal bid items.

950.3.2 General Install

- (1) Contractor shall conform to WisDOT Standard Specifications for Highway and Structure Construction for construction methods.
- (2) Contractor shall provide all necessary equipment and tools to install video equipment, EVP detector, and or wireless antennas as defined on the signal plans.
- (3) Contractor shall verify mounting location with engineer or electrician prior to mounting any equipment on the signal poles.
- (4) Contractor shall provide incidental items such as wire nuts, grommets, tape connectors, electrical nuts, etc., necessary to make the system complete from the signal cabinet to the remote unit.
- (5) Contractor shall follow manufacturer specifications for proper mounting directions.
- (6) Install the City furnished mounting brackets, extension arms (if required), and video units per manufacturer recommendations in the locations determined by the department.
- (7) Contractor shall conform to City of La Crosse Standard Procedures for camera and EVP cable installation.
- (8) Mark each end of the lead in the traffic signal cabinet and each cable in the pole handhole to indicate the equipment label (i.e. V1, V2, etc.) on the plans. For a cabinet that is not operating the signal, the contractor will terminate the ends. If the cabinet is operating the signal, the cabinet wiring will be done by the City.
- (9) Notify engineer upon completion of the installation and aiming of the specialty units.



Engineering Department

400 La Crosse St., La Crosse, WI 54601 • (608) 789-7505 • Fax: (608) 789-8184
http://www.cityoflacrosse.org

- (10) Assist the City and vendor with aiming and programming the equipment during turn-on. The City will schedule the equipment turn-on and provide a notification a minimum of five working days prior.
- (11) Coordinate directly with the City’s video system vendor to arrange for the vendor to program the video detection system on site. Notify the City and vendor at least five working days prior to the date of programming. Assist the City and vendor with fine adjusting of the video units during the video system programming, if necessary.

950.3.3 Gridsmart Video Equipment

- (1) Contractor shall install cable run continuously from the camera assembly to the signal control cabinet. The engineer will determine the exact location of the camera to ensure that the installation does not create a sight obstruction.
- (2) Coordinate directly with the City’s Gridsmart vendor {(865) 296-1315 or chuck.wilson@gridsmart.com} to schedule the Gridsmart acceptance testing. Coordinate with the City electrician to participate in the acceptance testing. The City has final determination of the Gridsmart acceptance testing date and time. After the contractor has mounted the camera on the pole, he shall connect all the field wiring inside the signal cabinet.

950.3.6 Emergency Vehicle Preemption Detector

- (1) Install the EVP detector heads as shown on the plans. The City will determine the exact location to ensure that the installation does not create a sight obstruction. Mount the EVP detector heads and wire them per manufacturer instructions. For a cabinet that is not operating the signal, the contractor will terminate the ends and install the discriminators and card rack in the cabinet. If the cabinet is operating the signal, the cabinet wiring will be done by the City.
- (2) Coordinate directly with the City’s vendor {GTT at (651) 245-8709 or larry.pope@gtt.com / TAPCO at (262) 814-7327 or rickk@tapconet.com / TCC at 651-439-1737 or mallwood@trafficcontrolcorp.com} to schedule the EVP acceptance testing. Coordinate with the City electrician to participate in the acceptance testing. The City has final determination of the EVP acceptance testing date and time.

950.4 Measurement

- (1) The department will measure each (EA) Specialty Signal Equipment successfully installed.
- (2) Video equipment will be measured by the intersection completely installed.
- (3) EVP detector and wireless antennas shall be measured by the pole installation.

950.5 Payment

The department will pay for the measured quantity at the contract unit price under the following bid item:

ITEM NUMBER	DESCRIPTION	UNIT
950	Install Gridsmart Video Equipment (location)	EA
951	Install EVP detector (pole)	EA
952	Install Wireless Antennas (pole)	EA

950.6 Testing, Acceptance, & Maintenance

950.6.1 Aboveground Inspection

- (1) Contractor shall conform to Aboveground Inspection requirements in the City of La Crosse Standard Procedures.

950.6.2 Signal Turn on Inspection

- (1) Contractor shall inform the City when Signal Cabinet components are ready for inspection. The City Inspector or Engineer shall review all signal cabinet installations three (3) business days after inspection request from the contractor. Contractor may inspect signal cabinet installations with the Inspector or Engineer.
- (2) Contractor shall use “Signal Turn-on Form” and shall submit form to engineer.



Engineering Department

400 La Crosse St., La Crosse, WI 54601 • (608) 789-7505 • Fax: (608) 789-8184
<http://www.cityoflacrosse.org>

- (3) Operate the completed traffic signal installation for 72 hours consecutively, using the specified signal sequence and all special functions, such as preemption, as the plans show, or as the engineer approves.
- (4) The traffic signal installation is not complete until the electrical work is complete and electrical systems work properly.



955-TEMPORARY SIGNAL

955.1 General Description

- (1) This section describes the installation, maintenance, and operation of a temporary traffic signal within the project limits.

955.2 Materials

- (1) Temporary Traffic Signal material shall conform to WisDOT Standard Specifications for Highway and Structure Construction except as modified below.
- (2) Signal heads, pedestrian heads, pedestrian buttons, and signal housing shall conform to City of La Crosse Standard Procedures.
- (3) Contractor shall submit a complete list of signal components and hardware after awarding of the bid to the engineer.

955.3 Construction Methods

- (1) Temporary Traffic Signal construction methods shall conform to WisDOT Standard Specifications for Highway and Structure Construction except as modified below.
- (2) Perform work according to the WSEC. Provide and install wood poles, posts, tether wire, messenger wire, tether wire hardware, messenger wire hardware, guy wire, span wire, guy wire hardware, and span wire hardware, traffic signal cable, traffic signal faces mounting hardware, electrical service, traffic signal faces, traffic signal faces with backplates, including providing, installing, and programming the controller with control cabinet as the plans show.
- (3) The engineer will determine final wood pole locations after marking the utilities.
- (4) Contractor shall contact the engineer to obtain and install the existing traffic signal phasing and timings at each intersection.
- (5) All far through indications suspended on the span wire shall be located above the center of the controlled lane. The far-right signal shall be mounted over the center of the right through lane. The far-left turn signals shall be suspended straight ahead of the left turn lane.
- (6) Remove the temporary traffic signal faces the same day the permanent traffic signal is turned on. Remove wood poles within 3 days of new permanent signal activation.

955.4 Measurement

- (1) The department will measure Temporary Traffic Signal as a lump sum (LS) amount.
- (2) 50% shall be paid at temporary signal turn on and remainder shall be paid when temporary signal is fully removed and site restored.

955.5 Payment

The department will pay for the measured quantity at the contract unit price under the following bid item:

ITEM NUMBER	DESCRIPTION	UNIT
955	Temporary Traffic Signal	LS

955.6 Testing, Acceptance, & Maintenance

- (1) Request a signal inspection of the complete temporary traffic signal installation. Make this request to the engineer at least 10 business days before the requested inspection. City electrical personnel will perform the inspection.
- (2) Contractor may inspect temporary signal installations with the Inspector or Engineer.



Engineering Department

400 La Crosse St., La Crosse, WI 54601 • (608) 789-7505 • Fax: (608) 789-8184
<http://www.cityoflacrosse.org>

- (3) The engineer will not grant turn on approval until the contractor corrects discrepancies. Contractor shall install temporary electrical service using the existing service unless otherwise directed by the engineer.

955.6.1 Maintenance

- (1) Contractor shall maintain minimum and maximum heights to the signal faces as the plans show. Contractor shall maintain a log of span heights to be monitored every week the temporary signal is in operation. Contractor shall provide a log at the request of the inspector or engineer.
- (2) Provide a primary contact as well as a backup contact assigned to and qualified to maintain temporary traffic signals. Submit names, addresses, and telephone numbers of contact persons to the engineer, local police, and county sheriff. Also post contact information on temporary traffic signal control cabinets and cover with weatherproof material. Ensure that a contact person is available 24 hours a day, 7 days a week, from the start of the project until the temporary traffic signal is not needed. Ensure that emergency calls are received by an individual and not by an answering machine.
- (3) Respond within one hour of notification to correct LED outages. If equipment is damaged or faulty due to a knockdown, replace it within one working day. Replace any damaged signal control equipment within four (4) hours.



960-SIGNAL COMMUNICATION EQUIPMENT

960.1 General Description

- (1) This section describes transporting and installing traffic signal communication equipment within the project limits.

960.2 Materials

- (1) City of La Crosse shall provide the Fiber optic cable, pre-terminated fiber optic patch panel, and ethernet switch. Contractor shall schedule a pick-up time 5 business days in advance of material pick up from the municipal storage unit.
- (2) All materials under this item shall meet the requirements of WisDOT Standard Specifications for Highway and Structure Construction.
- (3) Contractor shall provide a 1-meter length of CAT-5e cable from the Ethernet switch to the controller. Provide a 1-meter length of CAT-5e cable from the Ethernet switch to the Interface Panel. CAT-5e patch cords shall have factory pre-terminated RJ45 / 8P8C connectors on both ends per TIA/EIA T568B. Provide all patch panel, Ethernet switch, and Interface Panel attachment hardware.

960.2.1 Fiber Cable and terminations

- (1) The City will furnish fiber optic cable, termination panel, and pre-terminated fiber optic patch panels. The materials will be provided with the traffic signal cabinet. The patch panels will have pre-terminated fiber optic cable pigtailed.
- (2) Contractor shall provide two each 1-meter lengths of ST-LC single mode fiber jumper (2 fibers per jumper) from the termination panel to the Ethernet switch.
- (3) Termination panels within City buildings shall use LC type terminations.

960.2.3 Tracer Wire

- (1) Provide a 12 AWG XLP insulated, copper, 600 volt AC locate wire through the conduit run. Wire shall be yellow in color. Connect the locate wire by using a silicone filled wire nut at each pull box, vault or other access point. Alternatively, use a single wire through the access points, leaving a 6 foot coil in each pull box, vault or other access point for splicing.

960.2.4 Fiber Conduit

- (1) Use schedule 40 PVC electrical conduit conforming to WisDOT Standard Specifications for Highway and Structure Construction.

960.2.5 Ethernet Switch

- (1) The City will furnish programmed managed Ethernet switches.

960.2.6 Radio Antennas

- (1) Contractor shall furnish cables and connectors required to install radio antenna. Radio cable shall conform to manufacturer's recommendations.
- (2) City of La Crosse shall furnish radio antenna, mounting hardware, and cabinet interface panel.

960.2.7 Testing Station

- (3) City shall provide testing station to be installed as designated on the plans. All materials required for the test station shall be incidental to the item.
- (4) The following Copperhead Snakepit testing station models are acceptable for City construction and shall be Orange in color. Substitutions shall be approved by the Engineer prior to delivery to the job site.

Testing Station Model	
Testing Station Location	Model Number
Boulevard Grass	LD14*2T-SW
Concrete/Driveway	CD14*2T-SW



960.3 Construction Methods

960.3.1 General Install

- (1) Contractor shall conform to WisDOT Standard Specifications for Highway and Structure Construction for construction methods.
- (2) Contractor shall provide all necessary equipment and tools to install fiber optic cable, termination panels, fiber optic splices, and or wireless antennas as defined on the plans.

960.3.2 Fiber Optic Cable Install

- (1) Fiber Optic Cable shall conform to construction requirements in WisDOT Standard Specifications for Highway and Structure Construction.
- (2) The Contractor shall install fiber optic cable as shown on the plans. Coiled slack shall be determined by the location whereas, all pull boxes shall contain 20 feet, all vaults shall contain 50 feet, and signal cabinets shall contain 15 feet unless otherwise noted. Fiber optic cable within shared signal pull boxes shall be grounded per standard procedures.

960.3.3 Fiber Optic Splices

- (1) Fiber Optic Splices shall conform to the construction requirements in WisDOT Standard Specifications for Highway and Structure Construction.
- (2) Splices shall be made in pull boxes or vaults as shown on the plans.

960.3.4 Terminations and Ethernet Switch

- (1) Install the patch panel and Ethernet switch on the side of the traffic signal cabinet opposite the electrical service at a location as approved by the engineer. With approval by the engineer, the Ethernet switch may be placed on a shelf near the patch panel. Install the pre-terminated fiber optic cable in conduit from the patch panel to the communication vault as specified in WisDOT Standard Specifications for Highway and Structure Construction. Fiber optic cable ends shall be covered securely to protect open ends during installation in raceways. Leave the remainder of the fiber optic cable coiled in the communication vault.
- (2) Install the fiber jumpers and CAT-5e cable and provide a communications link from the communication vault to the controller. Install the CAT5-e cable from the Interface Panel to the Ethernet switch.
- (3) Terminate fibers on the rear of the termination panel with type ST or type LC connectors as noted on the plans.

960.3.5 Radio Antennas

- (1) Contractor shall conform to WisDOT Standard Specifications for Highway and Structure Construction for construction methods.
- (2) Contractor shall verify mounting location with engineer or electrician prior to mounting any equipment on the signal poles.
- (3) Contractor shall provide incidental items such as wire nuts, grommets, tape connectors, electrical nuts, etc., necessary to make the system complete from the signal cabinet to the remote unit.
- (4) Pole mount antennas as the plans show and conforming to manufacturer's recommendations. Connect to the devices the plans show or engineer directs.
- (5) Mark each end of the lead in the traffic signal cabinet and each cable in the pole handhole to indicate the equipment label (i.e. R1, R2, etc.) on the plans. For a cabinet that is not operating the signal, the contractor will terminate the ends. If the cabinet is operating the signal, the cabinet wiring will be done by the City.
- (6) Coordinate directly with the City's vendor {TAPCO at (262) 814-7327 or rickk@tapconet.com} to schedule the radio acceptance testing. Coordinate with the City electrician to participate in the acceptance testing. The City has final determination of the acceptance testing date and time. After the contractor has mounted the radio antenna, he shall connect all the wiring inside the controller cabinet. Connecting and testing wiring shall be considered part of this item of work.



960.3.6 Pull box with Fiber Test Station

- (1) Pull box installation shall conform to City of La Crosse Standard Specifications and Procedures and shall be paid for with the separate item.
- (2) Test station shall be flush with concrete, brick paver system, or grass boulevard surface. Test station shall be installed next to fiber pull box as directed by City staff.

960.4. Measurement

- (1) The department will measure install fiber optic cable and install fiber optic pigtail by the linear foot (LF), including extra coils of fiber in pull boxes as defined in the City of La Crosse Standard Procedures.
- (2) The department will measure remaining items as each (EA) installation successfully completed. Fiber Optic Splice Enclosure, Ethernet Switch, and Termination Panel are measured as each (EA) item successfully installed. Fiber Optic Splice is measured as each (EA) fiber optic splice successfully completed.

960.5. Payment

The department will pay for the measured quantity at the contract unit price under the following bid item:

ITEM NUMBER	DESCRIPTION	UNIT
960.01	Install fiber optic cable	LF
960.02	Fiber Optic Splice Enclosure	EA
960.03	Fiber Optic Splice	EA
960.04	Install Fiber Optic Pigtail	LF
960.05	Install Ethernet Switch	EA
960.06	Install Fiber Optic Termination Panel	EA
960.07	Install Fiber Test Station	EA

960.6 Testing, Acceptance, & Maintenance

960.6.1 Underground Inspection

- (1) Contractor shall conform to Underground Inspection requirements in the City of La Crosse Standard Procedures.

960.6.2 Aboveground Inspection

- (1) Contractor shall conform to Aboveground Inspection requirements in the City of La Crosse Standard Procedures.

960.6.3 Signal Turn on Inspection

- (1) Contractor shall inform the City when Signal Cabinet components are ready for inspection. The City Inspector or Engineer shall review all signal cabinet installations three (3) business days after inspection request from the contractor. Contractor may inspect signal cabinet installations with the Inspector or Engineer.
- (2) Contractor shall use "Signal Turn-on Form" and shall submit form to engineer.
- (3) Operate the completed traffic signal installation for 72 hours consecutively, using the specified signal sequence and all special functions, such as preemption, as the plans show, or as the engineer approves.
- (4) The traffic signal installation is not complete until the electrical work is complete and electrical systems work properly.

960.6.4 Communication System Testing

- (1) Contractor shall supply materials and equipment necessary to perform the communication system testing as described in WisDOT Standard Specifications for Highway and Structure Construction.
- (2) Contractor shall provide documentation including ODTE report, splice form, termination form, fiber assignments, and communication diagram. Documentation shall be incidental to the fiber optic splice item.
- (3) Contractor shall submit 1 electronic copy of the test results to the engineer including a summary document.



970- PAVEMENT MARKING GENERAL

970.1 General Description

- (1) Perform work in accordance with the provisions of WisDOT Standard Specifications for Highway and Structure Construction except as hereinafter modified.

970.2 Materials

- (1) All Materials shall be on the WisDOT APL List and conform to WisDOT Standard Specifications for Highway and Structure Construction except as hereinafter modified.

970.3 Construction Methods

- (1) All construction methods shall be in accordance with the provisions of WisDOT Standard Specifications for Highway and Structure Construction except as hereinafter modified.
- (2) All markings shall conform to City of La Crosse Detail Drawing. The markings shall follow the attached plans unless approved otherwise by the project engineer.
- (3) Latex (L) markings shall be applied to the surface of the pavement. Epoxy (EP) markings shall be grooved in the pavement surface.

970.3.1 Removal

- (1) All marking shall be removed completely as shown on plans or as the engineer directs.
- (2) The markings may be removed by either a truck-mounted unit or a hand-held unit. A vacuum system needs to completely collect dust and debris from the removal

970.3.2 Bike Symbol

- (1) Bike symbol shall follow figure 9C-3A with no arrow from the MUTCD or detail D on page D-9-3
- (2) Bike symbol shall be three feet four inches wide and six feet long.

970.3.3 Sharrow Symbol

- (1) Sharrow symbol shall follow figure 9C-9 from the MUTCD manual or detail E on page D-9-3.
- (2) Sharrow symbol shall have the overall dimensions of three feet four inches wide and nine feet three inches long. It will comprise of the standard bike symbol with two chevrons above.

970.3.4 Speed Table

- (1) Speed table markings shall look like figure 3B-39 option B from the MUTCD or detail Q on page D-9-3.
- (2) Triangles shall have an overall size of Six feet wide and Six feet long. Each triangle shall be comprised of two arrows. Each arrow shall be one foot wide and spaced one foot apart.

970.3.5 Continental Bar Crosswalk

- (1) Continental bars shall be six feet wide, two feet long, and have a spacing between bars of two feet.
- (2) Continental bars shall follow detail E on page D-9-3.

970.3.6 Yield Line Triangle

- (1) Triangles shall follow figure 3B-16 from the MUTCD or detail G on page D-9-3.
- (2) Triangles shall be 24 inches wide, 36 inches long, and spaced at six inches apart.

970.4. Measurement

- (1) The department will measure all long line marking removal by the Linear Foot (LF).
- (2) The department will measure all lettering by the square foot (SF) of the lettering.
- (3) The department will measure all symbols by the Each (EA) symbol.
- (4) The department will measure a removal plan by the Lump Sum (LS) for all work.



Engineering Department

400 La Crosse St., La Crosse, WI 54601 • (608) 789-7505 • Fax: (608) 789-8184
<http://www.cityoflacrosse.org>

970.5. Payment

The department will pay for the measured quantity at the contract unit price under the following bid item:

ITEM CODE	DESCRIPTION	UNIT
970.01	Paint Removal (Longline)	LF
970.02	Paint Removal (Letter)	SF
970.03	Paint Removal (Symbol)	EA
970.04	Paint Removal (Plan)	LS
971.01-.02	Pavement Markings (Material)	LS
972.01-.02	Bike Symbol (Material)	EA
973.01-.02	Sharrow Symbol (Material)	EA
974.01-.02	Speed Table Symbol (Material)	EA
975.01-.02	Continental Bar Crosswalk (Material)	EA
976.01-.02	Yield Line Triangle (Material)	EA

970.4 Testing, Acceptance, & Maintenance

N/A



980- DELINEATOR POSTS

980.1 General Description

- (1) Perform work in accordance with the provisions of WisDOT Standard Specifications for Highway and Structure Construction except as hereinafter modified.

980.2 Materials

- (1) Delineator posts shall be provided by City of La Crosse. The Contractor shall provide new posts if specified in the Specifications, plans, or as requested by the Engineer.
- (2) The Pexco Flexi-Guide model FG300 series are acceptable for City construction. Contractor shall provide any tools necessary to install delineator posts per vendor instructions.
- (3) Color shall be defined in the specifications, plans, or as defined by City staff. Substitutions shall be approved by the Engineer prior to delivery to the job site.

980.3 Construction Methods

- (1) All construction methods shall be in accordance with the provisions of WisDOT Standard Specifications for Highway and Structure Construction except as hereinafter modified.
- (2) Installation shall be per the vendor installation instructions.

980.4. Measurement

- (1) The department will measure all delineator posts per the each (EA) installed.

980.5. Payment

The department will pay for the measured quantity at the contract unit price under the following bid item:

ITEM CODE	DESCRIPTION	UNIT
980.01-.02	Delineator Post (color)	EA

980.4 Testing, Acceptance, & Maintenance

Contractor shall replace delineator posts and mounting bracket exceeding 5% of installation after one full year post installation at no cost to the City.

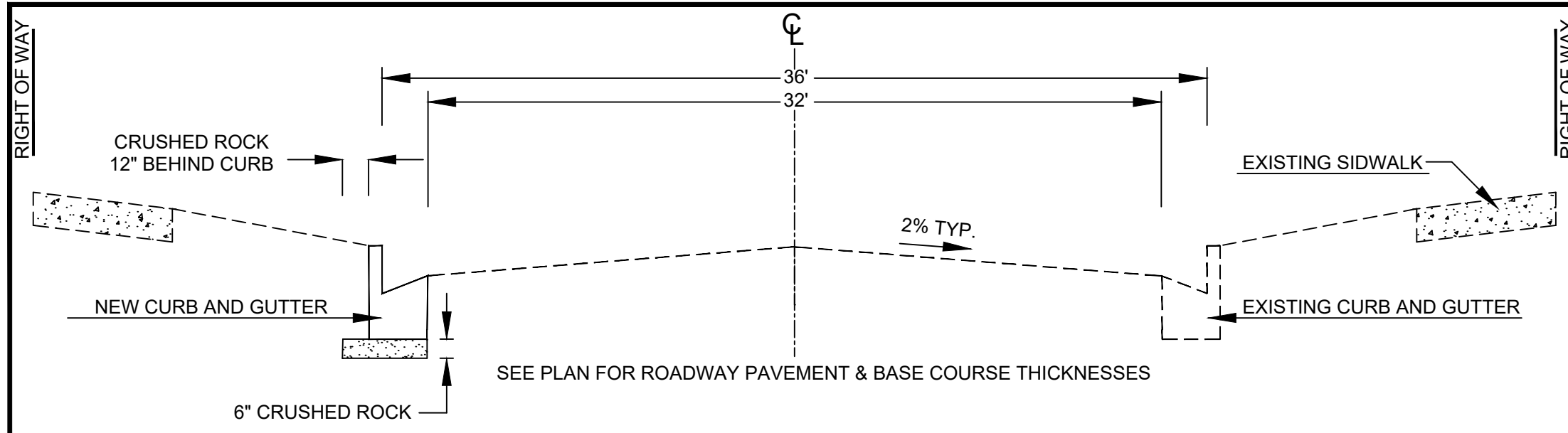

TYPICAL CROSS SECTION FOR 36' ROADWAY

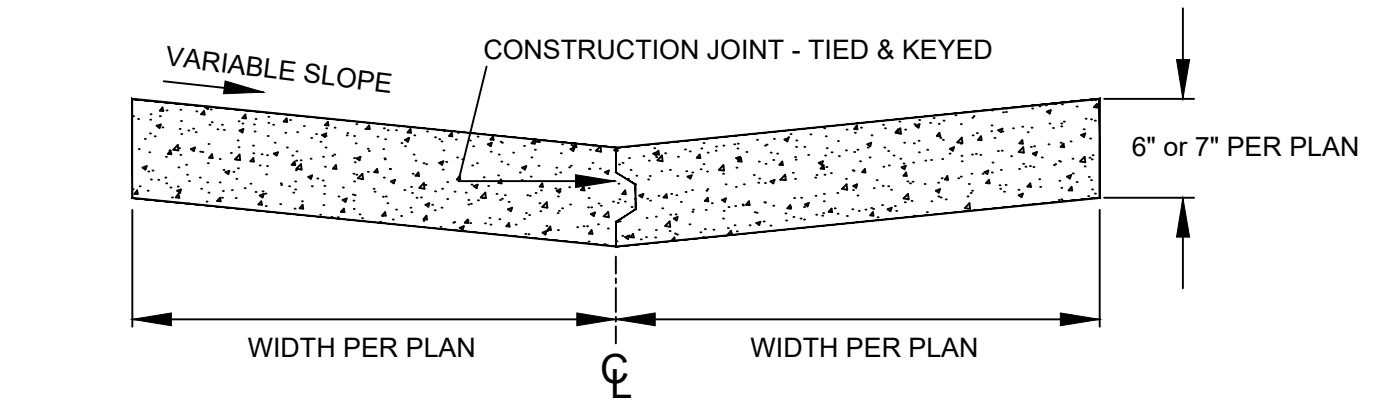

TYPICAL ALLEY PAVEMENT SECTION DETAIL

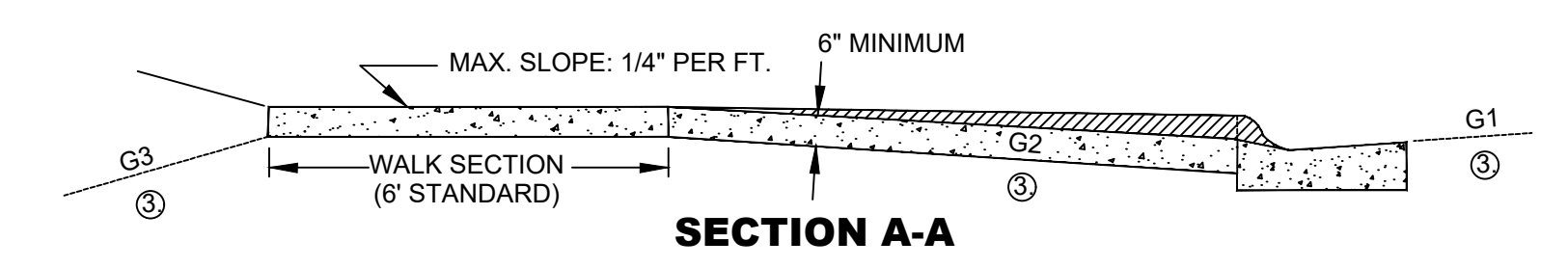
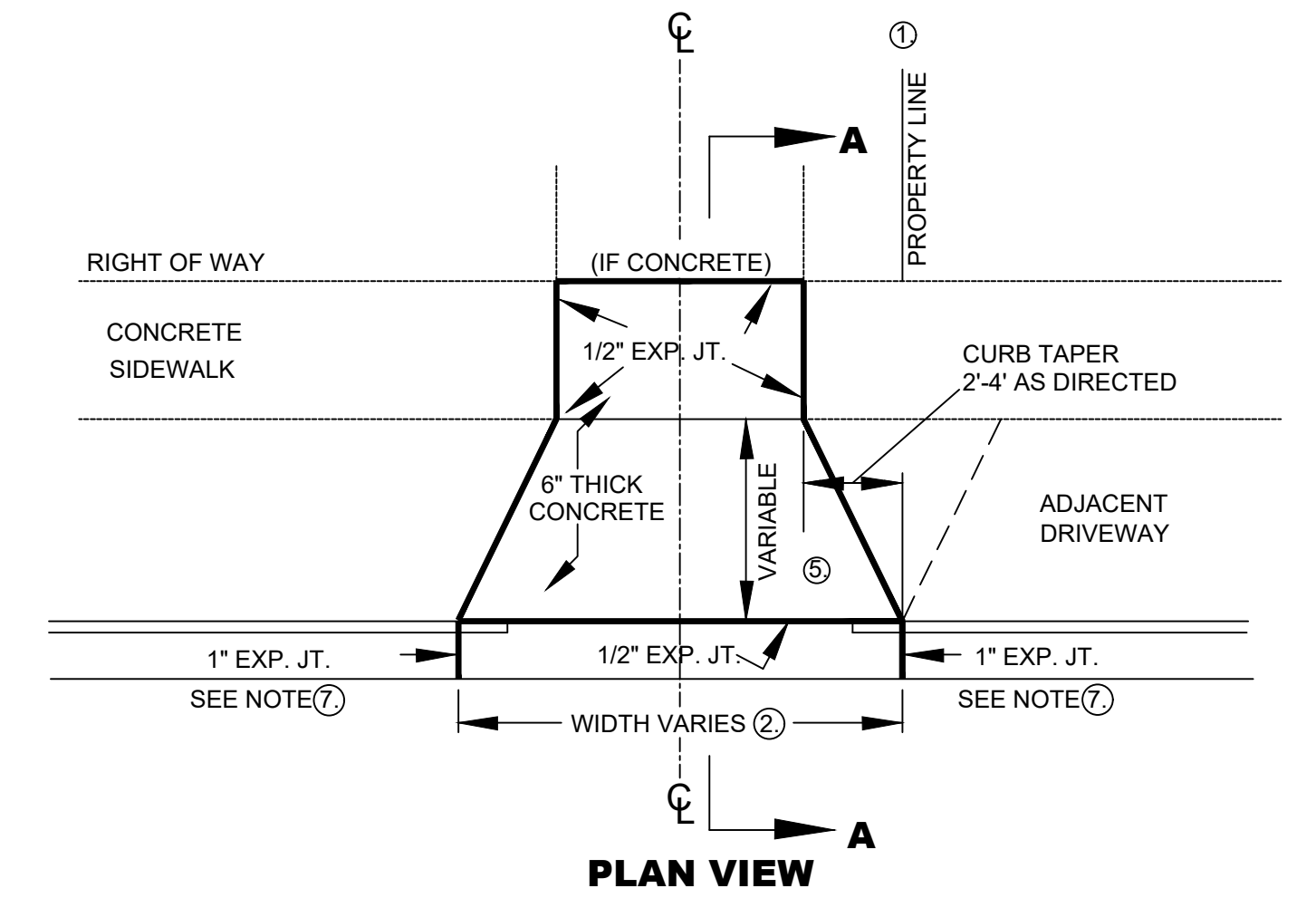

STANDARD DRIVEWAY DETAIL

- ① DRIVE SECTION SHALL NOT OVERLAP PROPERTY LINE EXTENDED, EXCEPT WHERE PERMITTED BY THE ENGINEER, OR WHEN A JOINT DRIVEWAY AGREEMENT IS EXECUTED BY OWNERS OF ADJACENT PROPERTIES.
- ② MAXIMUM DRIVEWAY WIDTH AT THE CURB AND SIDEWALK IS SET FORTH IN CITY ORDINANCE SEC. 40-4. FINAL DIMENSIONS SHALL BE APPROVED BY THE ENGINEERING DEPARTMENT.
- ③ THE BREAKOVER ANGLE (CAUSE OF CARS BOTTOMING) BECOMES CRITICAL WHEN THE ALGEBRAIC DIFFERENCE OF GRADES (G1, G2, & G3) EXCEEDS 11%.
- ④ A REINFORCED DRIVE SECTION IS REQUIRED FOR CURB & GUTTER IN AREAS ZONED INDUSTRIAL OR COMMERCIAL.
- ⑤ BACK OF CURB TO FRONT OF CONCRETE SIDEWALK MUST BE CONCRETE, BRICK OR ASPHALT.
- ⑥ MECHANICAL COMPACTION OF SUBSOIL IN LAYERS LESS THAN 12" TO ACHIEVE MINIMUM COMPACTION OF 95% OF MAXIMUM DENSITY FROM MODIFIED PROCTOR IS REQUIRED. (INCLUDING STREET SIDE AFTER FORMS ARE REMOVED)
- ⑦ EXPANSION JOINT IS REQUIRED AT BOTH ENDS OF DRIVEWAY WHEN ONLY DRIVEWAY IS INSTALLED OR REPLACED. WHEN ENTIRE BLOCK OF CURB & GUTTER IS INSTALLED THE EXPANSION JOINT AT DRIVEWAY ENDS MAY BE OMITTED.
- ⑧ TURNING OF 2' DIAMETER DRIVEWAY RETURNS IN LIEU OF DIMINISHING CURB AS SHOWN IS PERMITTED IF DESIRED BY PROPERTY OWNER.
- ⑨ INSTALLATION OF A DRIVEWAY BY REMOVING EXISTING CURB ONLY IS NOT ALLOWED. ENTIRE EXISTING C&G MUST BE REMOVED FOR NEW DRIVEWAYS. SAWING & REMOVAL OF A MINIMUM 2' WIDTH OF ASPHALT STREET PAVEMENT TO INSTALL FRONT FORMS IS REQUIRED.

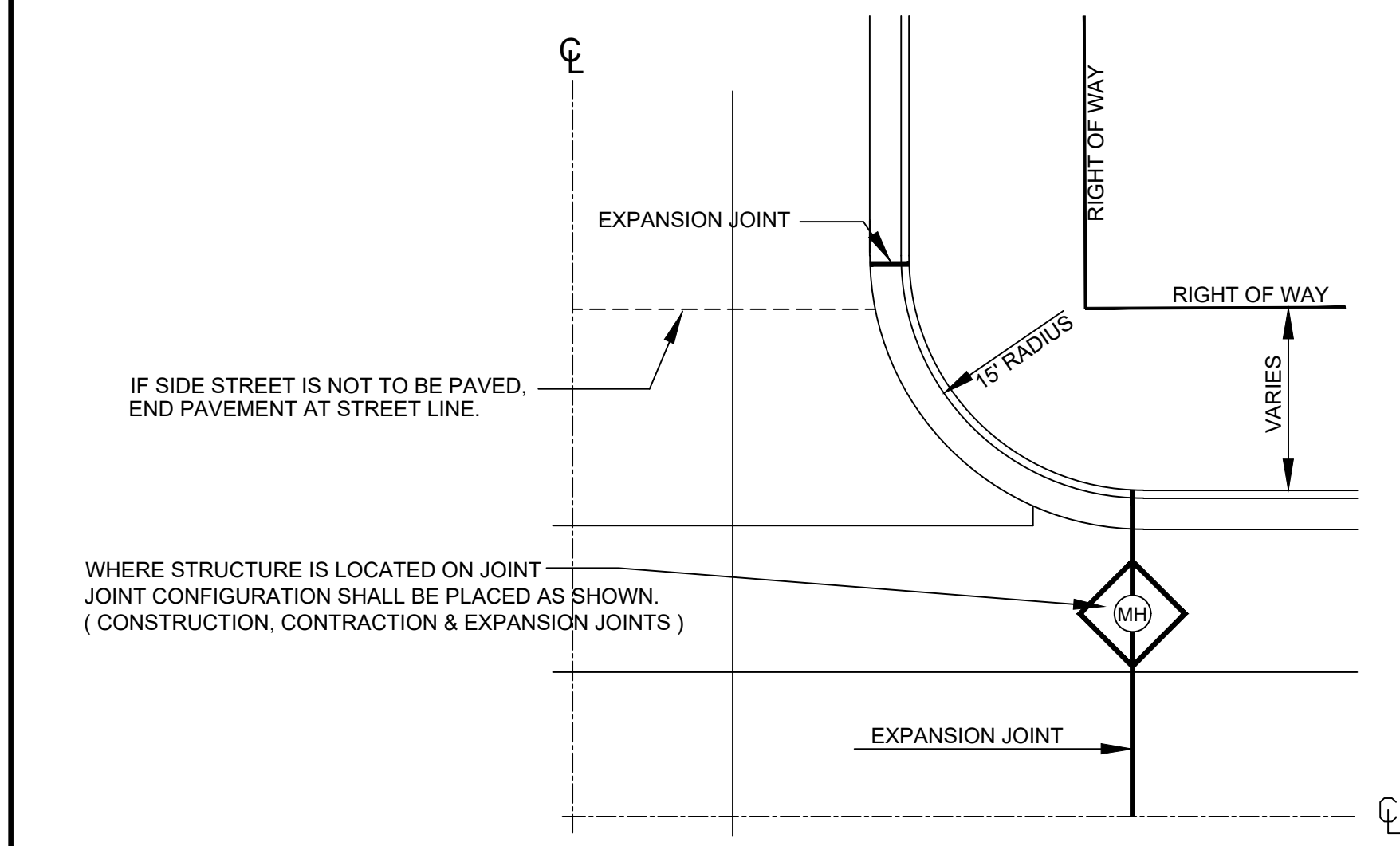

1/4 TYPICAL INTERSECTION

NOTES: JOINTS

1. EXPANSION JOINTS SHALL BE PLACED AT THE END OF RADII AT STREET INTERSECTIONS AND MID-BLOCK BETWEEN INTERSECTIONS. IN NO CASE SHALL THE DISTANCE BETWEEN EXPANSION JOINTS EXCEED 160 FEET.
2. THE DISTANCE BETWEEN TRANSVERSE JOINTS SHALL NOT BE LESS THAN 10 FEET AND SHALL BE TYPICALLY 20 FEET APART.
3. LONGITUDINAL CONSTRUCTION JOINTS BETWEEN CURB AND GUTTER SECTION AND CONC. PAVING SECTION SHALL BE SEALED AS SHOWN ON JOINT DETAILS.

CONCRETE PAVEMENT JOINT DETAILS

CONTRACTION

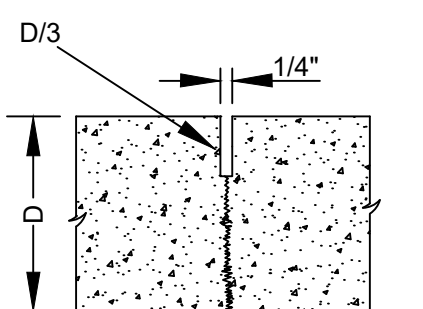

CONSTRUCTION

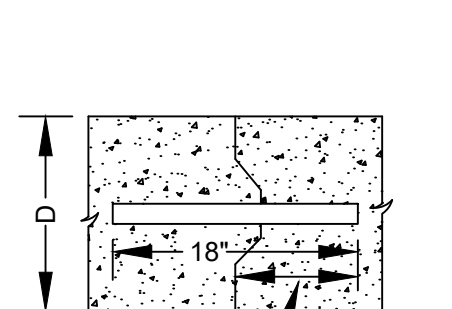

EXPANSION

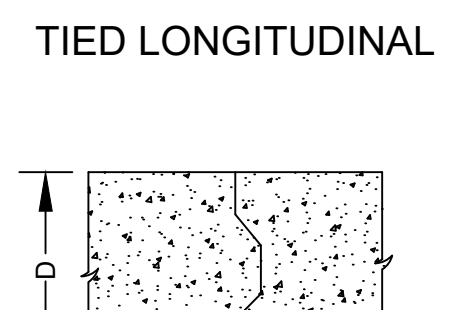
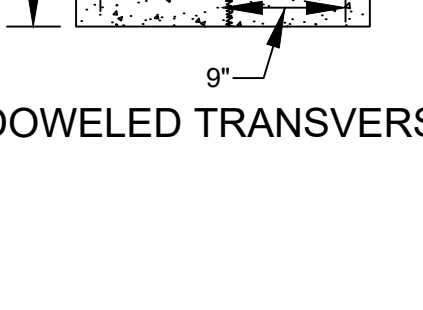
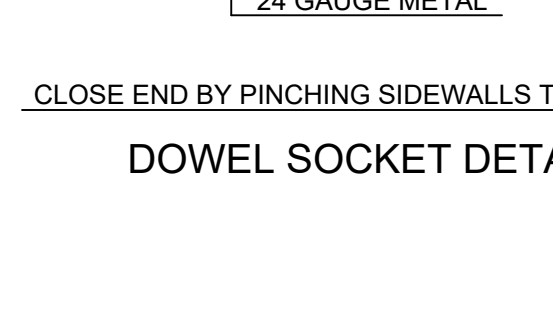
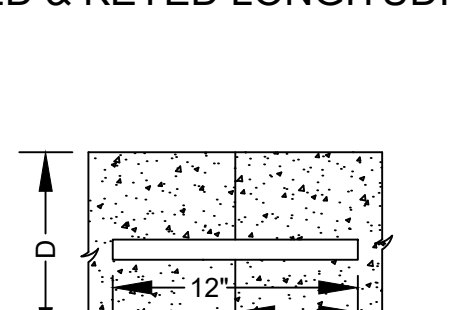
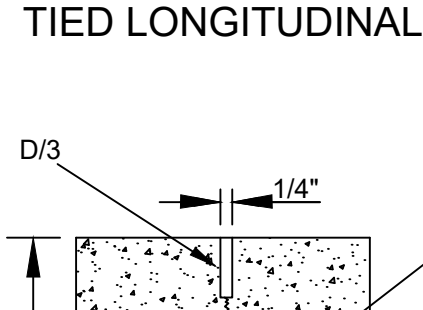
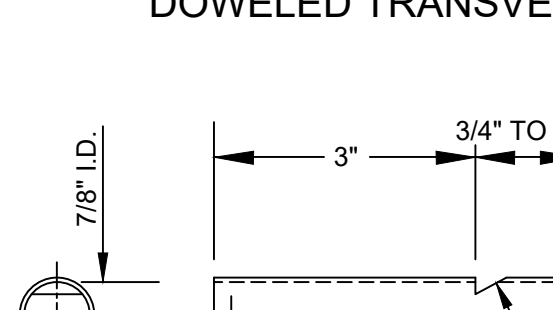
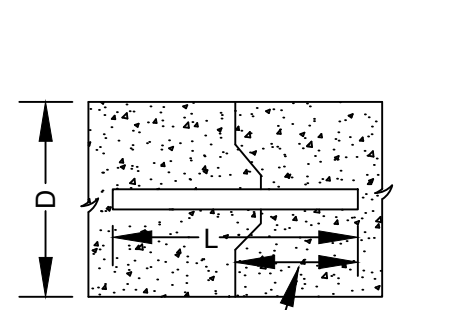
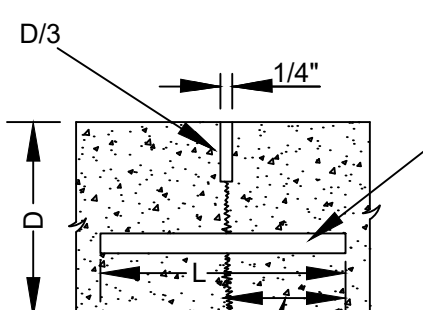
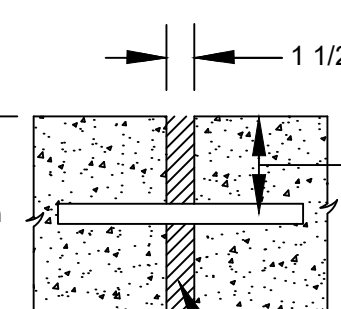

ALL JOINTS TO BE SEALED TO KEEP OUT FOREIGN DEBRIS

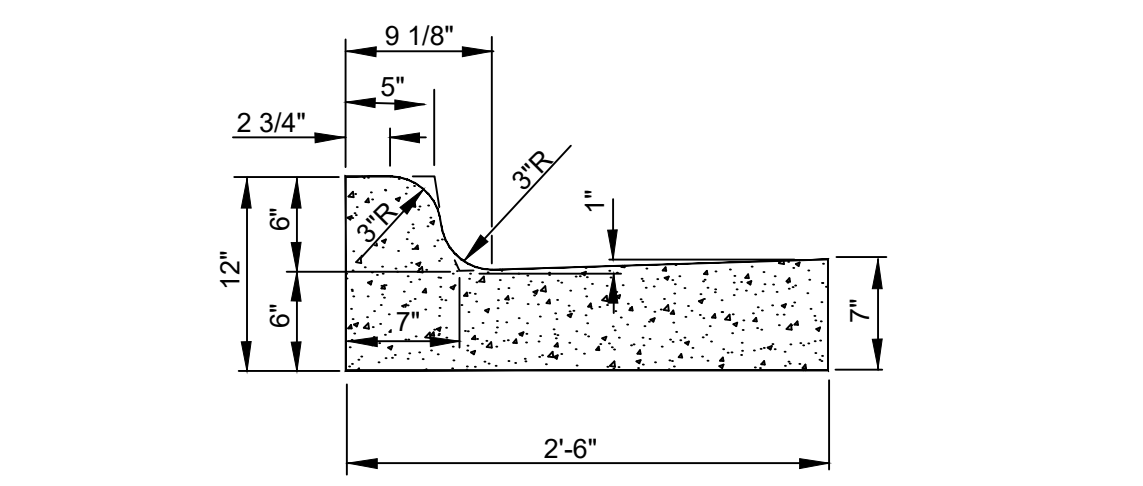

STANDARD CURB & GUTTER SECTION

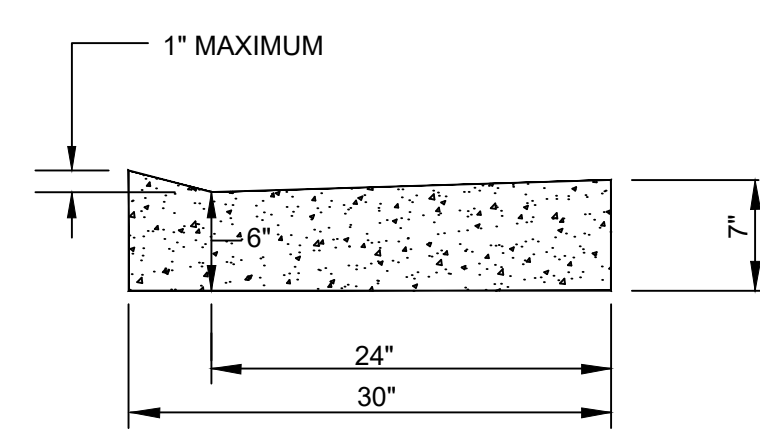

GUTTER ONLY SECTION

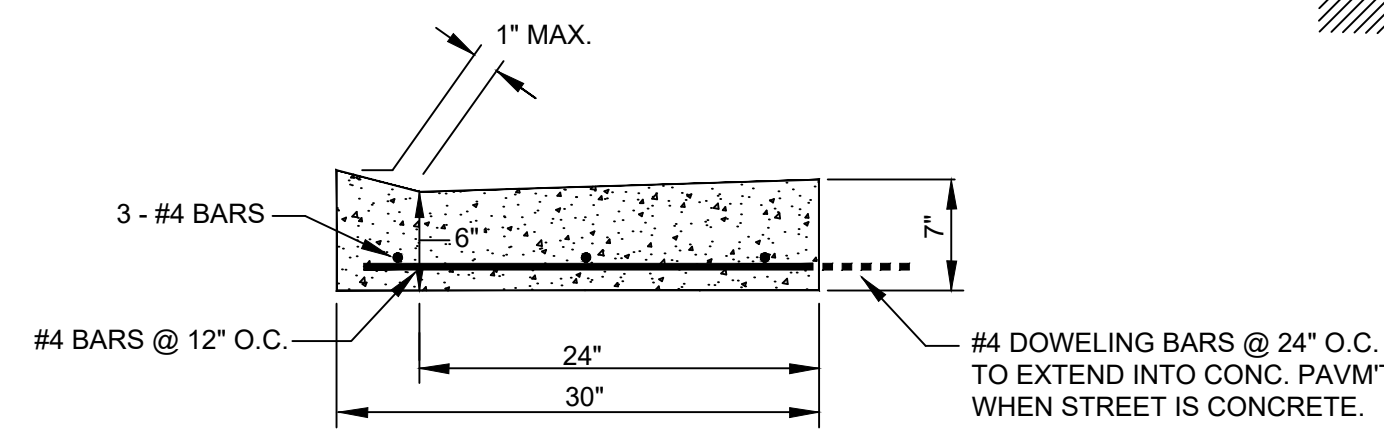

REINFORCED DRIVEWAY SECTION ④

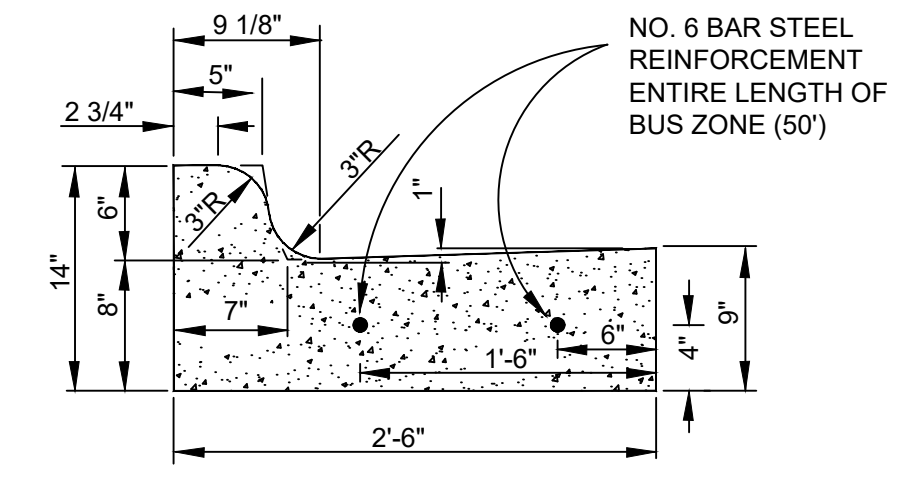

REINFORCED CURB & GUTTER SECTION (BUS STOP LOCATIONS)

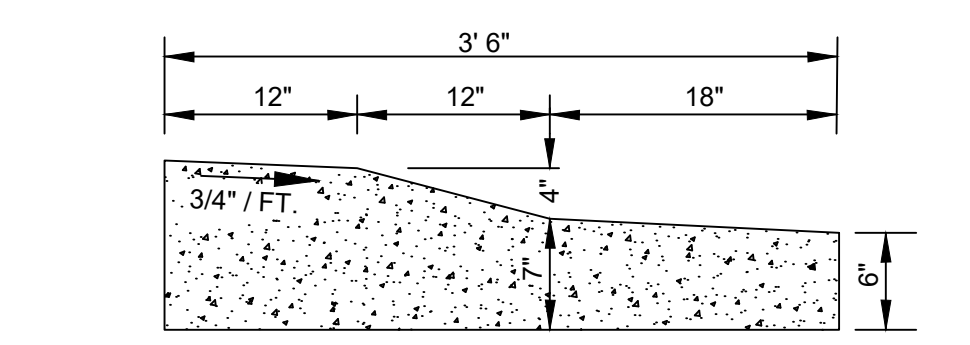

TRAFFIC CIRCLE CURB SECTION

DRAWINGS NOT TO SCALE

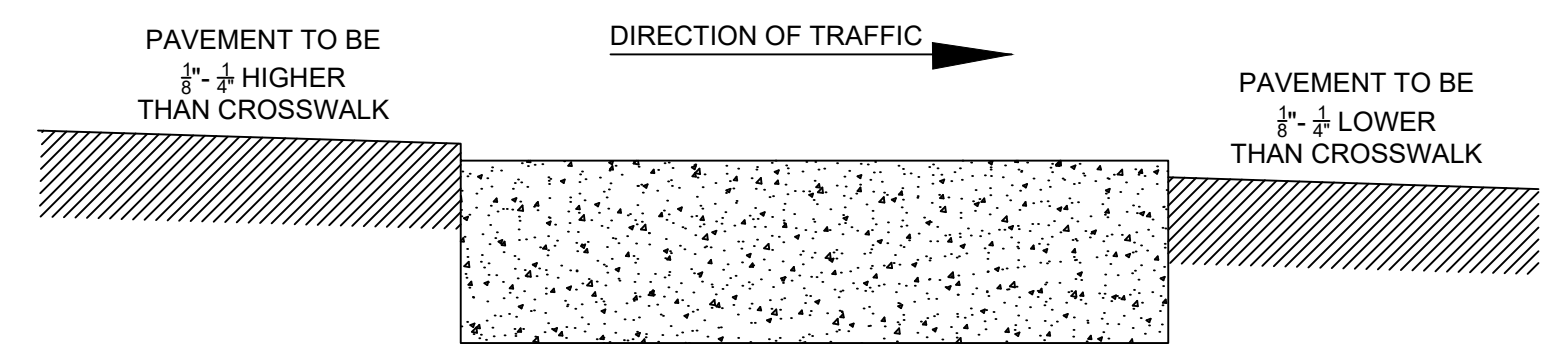

CONCRETE CROSSWALK DETAIL

STANDARD DETAIL D-1-1
CONCRETE PAVEMENT & CURB AND GUTTER

ENGINEERING DEPT.
 City of LaCrosse, Wis.

FIELD	REVISIONS	BY	DATE
BOOK	DRAWN	JMC	01/2021
NUMBER	CHECKED	JMC	11/2024
PAGE	APPROVED	JMC	
	REVISIONS		

SCALE: NONE

DRAWING
NOT TO SCALE

SEWER PIPE JOINT MATERIALS
CONCRETE PIPE-RUBBER GASKET (ASTM C-443)
PVC PIPE- ELASTOMETRIC GASKET (ASTM D-3212 & F-477)

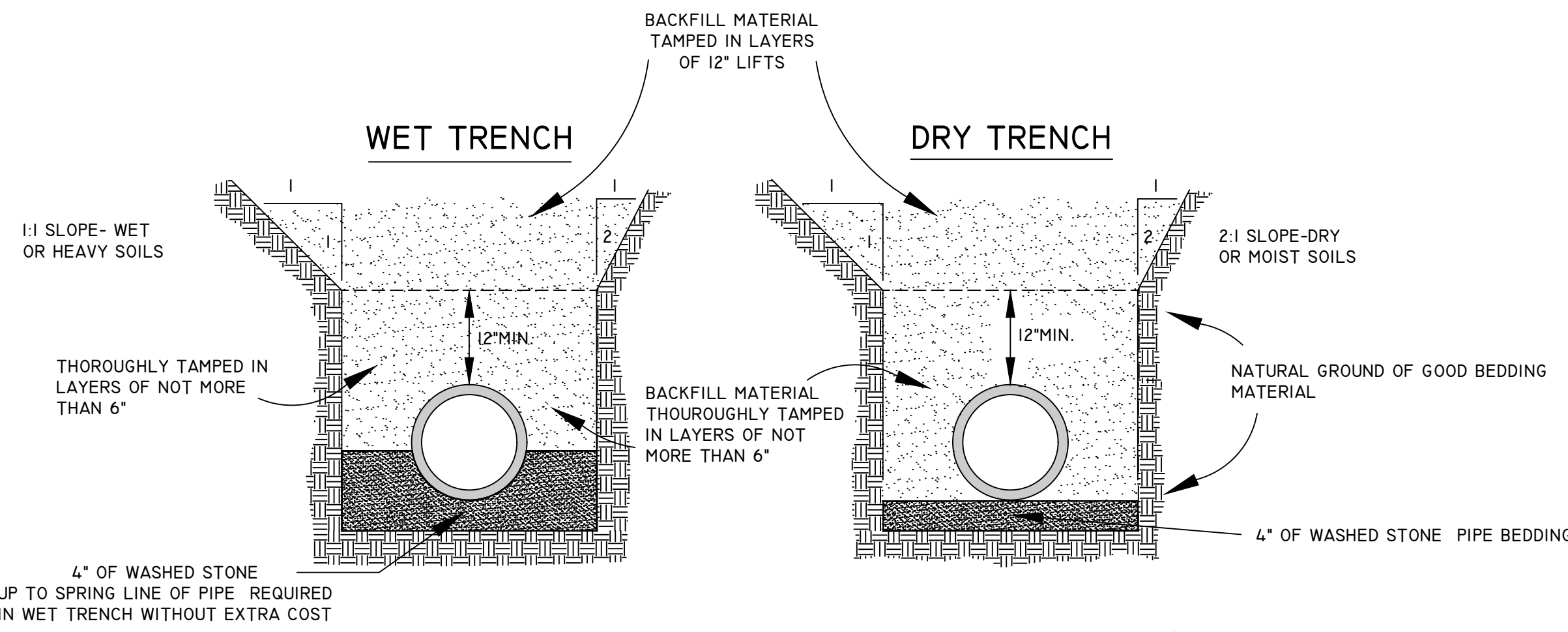

DETAILS OF SEWER TRENCHES

A
D-2

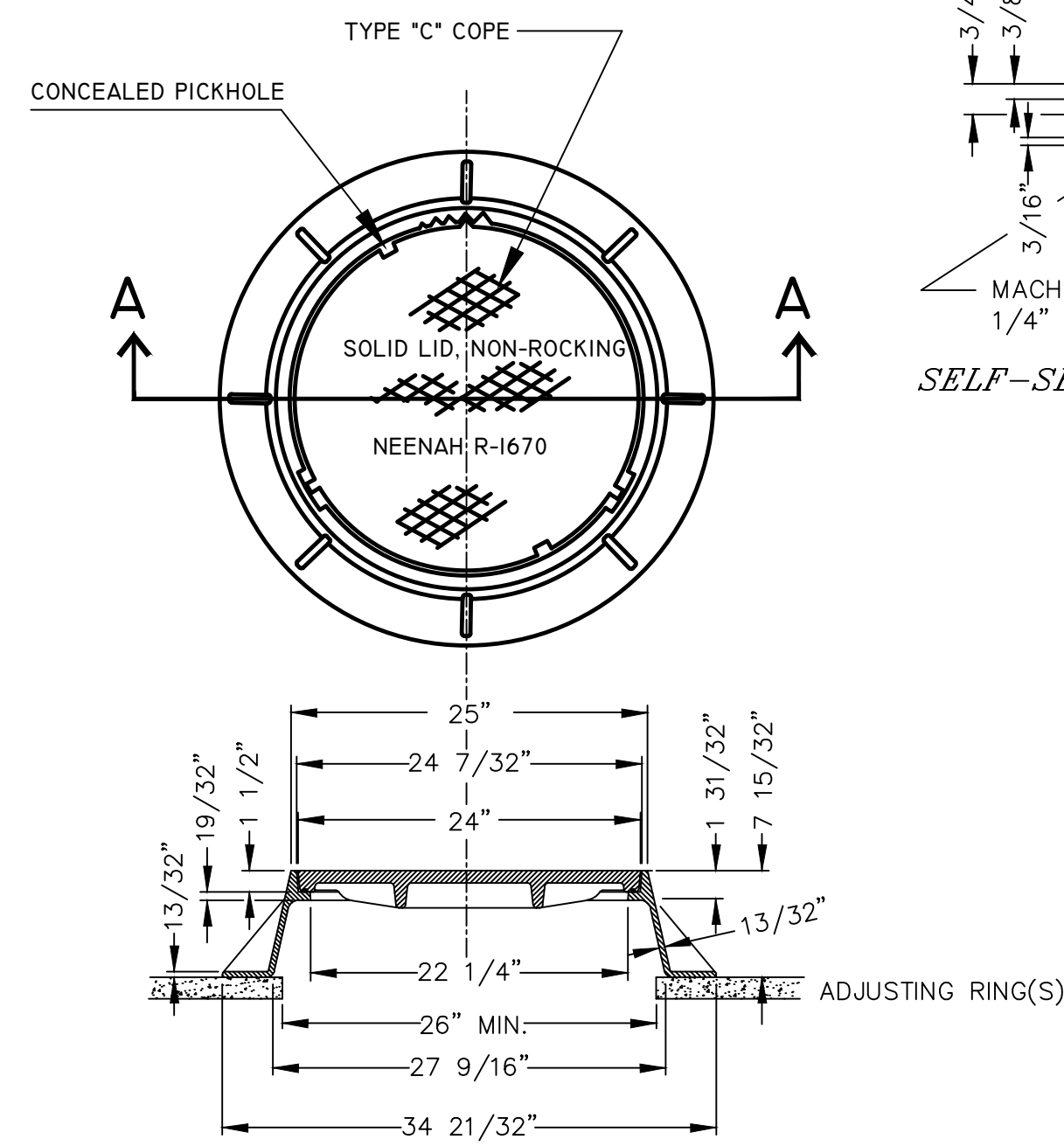

DETAIL OF MANHOLE FRAME & COVER

(MINIMUM WEIGHT 324 LBS. TOTAL)
NEENAH R-1670 OR EQUAL

NOTE

OPENING FOR FRAME & COVER SHALL BE CENTERED ON MANHOLES WITH FLAT TOPS.

B
D-2

NOTE 12

THE CONNECTION OF ALL PVC STORM WATER PIPE, SIZE 6" TO 30", TO PRECAST MANHOLES OR OTHER STRUCTURES SHALL EMPLOY A WATERTIGHT, FLEXIBLE PIPE-TO-MANHOLE CONNECTOR

THE CONNECTOR SHALL CONSIST OF A SINGLE RUBBER GASKET, SHALL BE CONSTRUCTED SOLELY OF SYNTHETIC OR NATURAL RUBBER, SHALL MEET/EXCEED THE REQUIREMENTS OF ASTM C 923, AND SHALL HAVE A MINIMUM TENSILE STRENGTH OF 1600 PSI

THE CONNECTOR SHALL BE THE SOLE ELEMENT RELIED ON TO ASSURE A FLEXIBLE, WATERTIGHT SEAL OF THE PIPE TO THE STRUCTURE

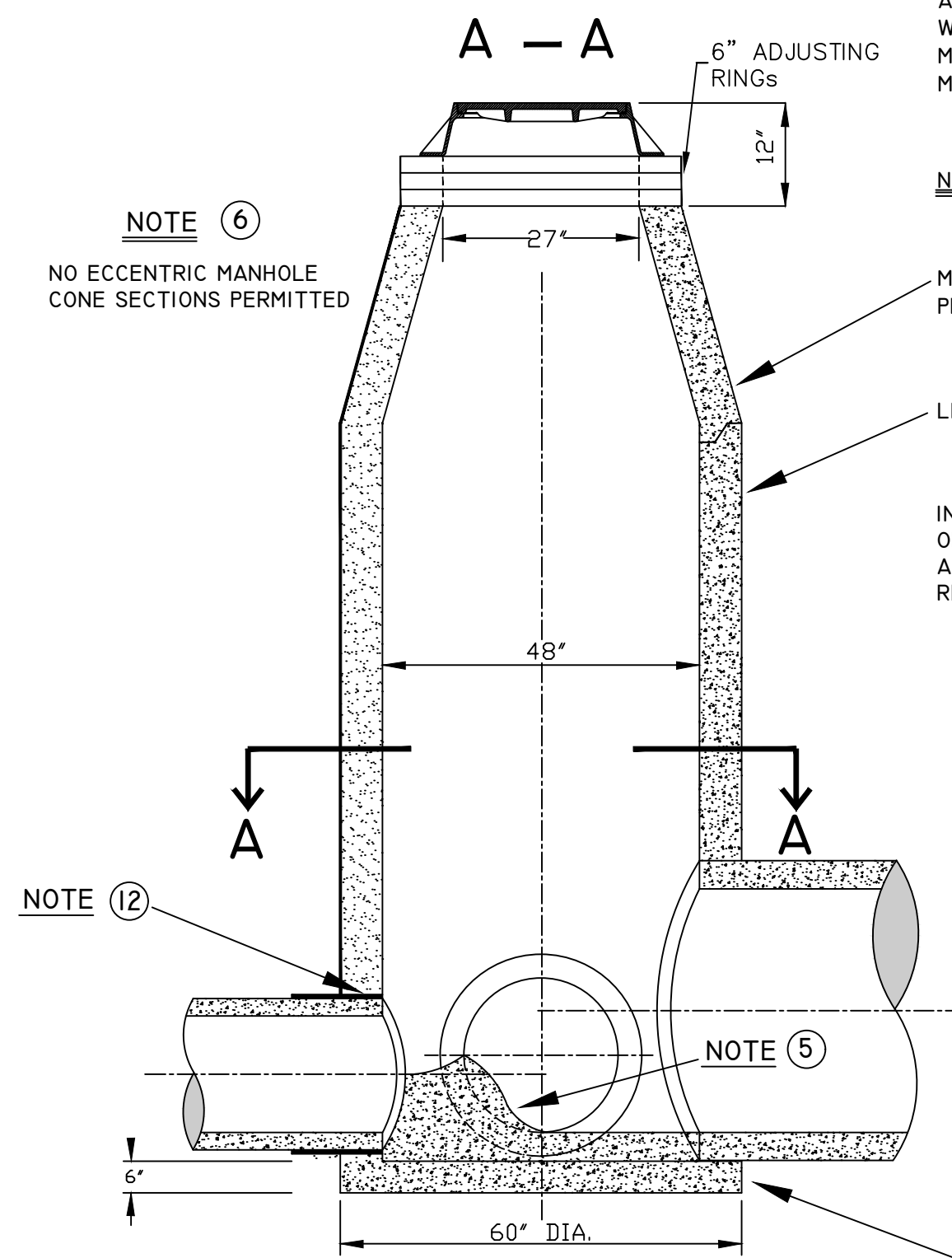
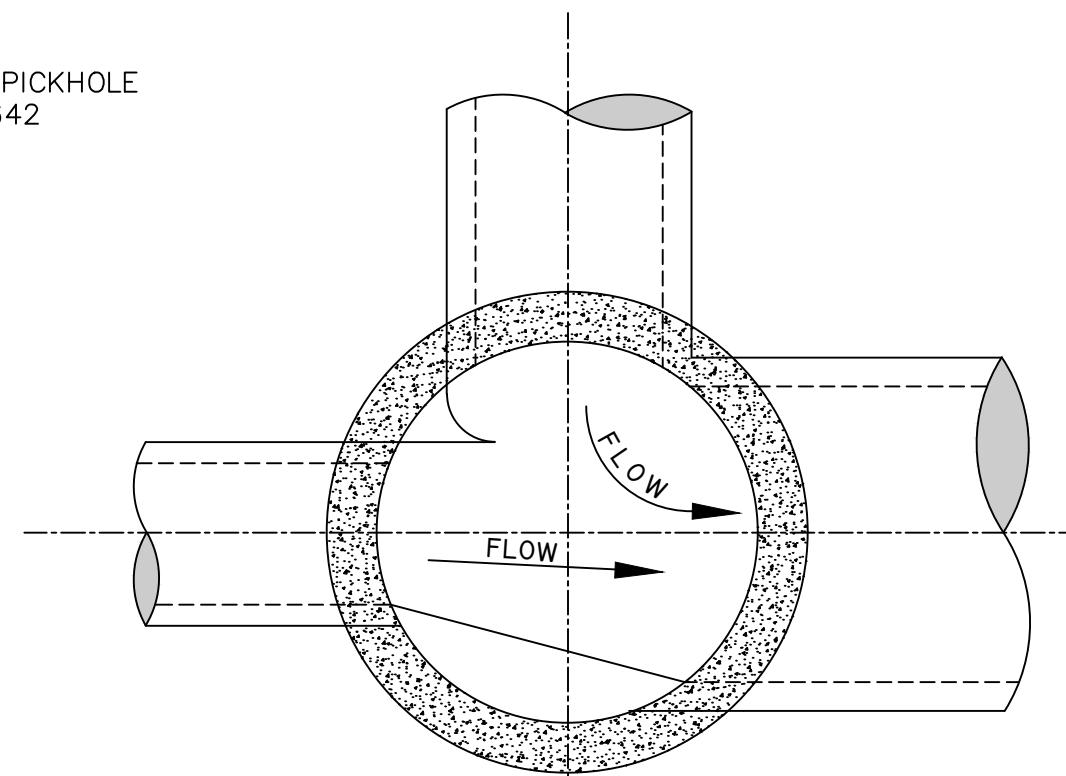

C
D-2 **DETAILS OF STANDARD MANHOLE FOR 30" PIPE OR SMALLER**

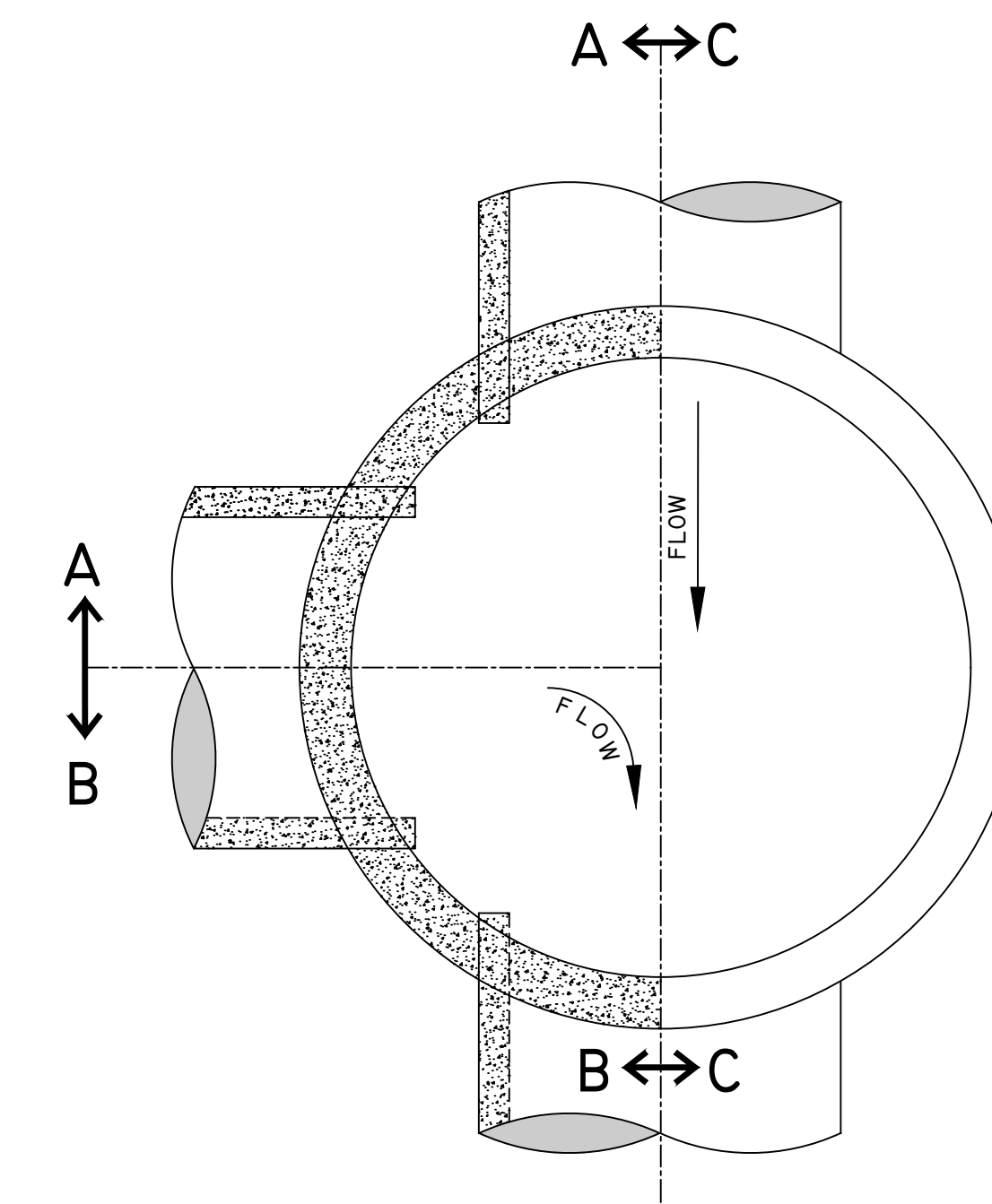

NOTE 1

TOP OF MANHOLE TO BE 12" BELOW FINISHED GRADE. ADJUSTMENT TO BE OF PRE-CAST CONCRETE RINGS WITH BUTYL GASKETS (ROPE) BETWEEN RINGS AND MORTER BETWEEN CASTING & TOP RING ONLY. (3/4" MORTAR MAX.)

NOTE 2

NO STEPS ARE TO BE INSTALLED IN MANHOLES

NOTE 3

MANHOLE TO BE CONSTRUCTED OF PRE-CAST CONCRETE (ASTM C-478).

NOTE 4

LIFT HOLES TO BE MANUFACTURED WATER PROOF

NOTE 5

INVERT TO BE FACTORY MOLDED TO PIPE DIA. OR FILLED TO DIRECT FLOW WITH 3/4" MAXIMUM AGGREGATE, 3500 P.S.I. CONCRETE IF M.H. IS NOT REPLACED

NOTE 7

ALL STRUCTURES TO BE MADE WITH PRE-CAST INTEGRAL FOOTING BASE. MIN. 6"

D
D-2 **DETAILS OF STANDARD MANHOLE FOR 36" PIPE OR LARGER**

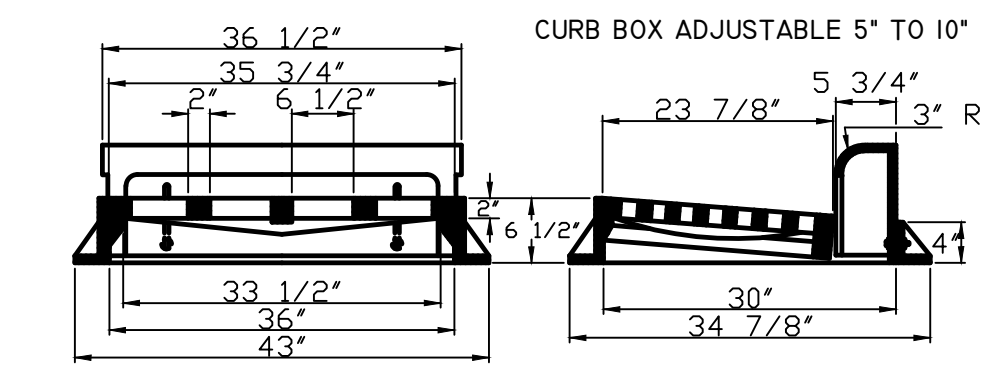

DETAILS OF TYPE "A" CATCH BASIN CASTING
NEENAH R-3246-A OR EQUAL
MINIMUM WEIGHT 649 LBS. TOTAL

F
D-2

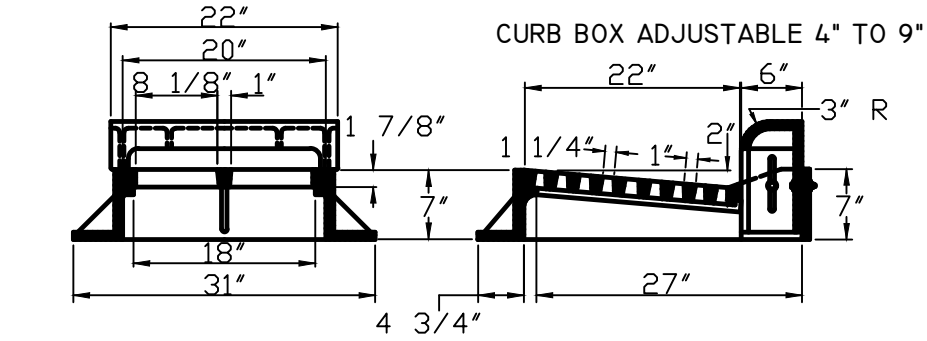

DETAILS OF TYPE "B" CATCH BASIN CASTING
NEENAH R-3234-B1 OR EQUAL
MINIMUM WEIGHT 400 LBS. TOTAL

NOTE:

"DUMP NO WASTE DRAINS TO RIVER"

SHALL BE MOLDED IN ALL CASTINGS FACE

NOTE 8

RECTANGULAR OPENING IN TOP
"B" TYPE CASTING - 27" X 22"
"A" TYPE CASTING - 36" X 30"

NOTE 9

TOP OF CATCH BASIN TO BE 12" BELOW CATCH BASIN FLOWLINE GRADE ADJUSTMENT TO BE MADE AS IN NOTE 1

NOTE 10

CONSTRUCTION OF CATCH BASIN TO BE THE SAME AS IN NOTE 9

E
D-2

DETAIL OF TYPE "A" OR "B" CATCH BASIN

STORM SEWER DETAILS
D-2

ENGINEERING DEPT.
City of LaCrosse, Wis.

FIELD	DATE	BY	DATE	
DESIGNED				
DRAWN				
CHECKED				
APPROVED				
REVISIONS				
	M.D.F.	3/03	J.M.C.	6/2015
	J.M.C.	9/03	B.E.M.	2/2019
	M.D.F.	4/06	J.M.C.	8/2019
	M.D.F.	12/10	J.M.C.	11/2023
	M.D.F.	4/13	J.M.C.	11/2024

SCALE: NONE

WATER SERVICE LATERAL DETAIL

SERVICE PIPE	CORP. STOP	CURB STOP	SERVICE BOX
1"	1"	1"	2 1/2"
1 1/4"	1 1/4"	1 1/4"	3"
1 1/2"	1 1/4" X 1 1/2"	1 1/2"	3"
2"	1 1/2" X 2"	2"	3"

CURB BOX : SEVEN FOOT BOX WITHOUT ROD-MUELLER # H10314, MC DONALD # 5601 OR EQUAL

54" or 57" ROD : MUELLER # 82868, MC DONALD # 5660 OR EQUAL

LID : MUELLER # 87081, MC DONALD # 5601-L OR EQUAL

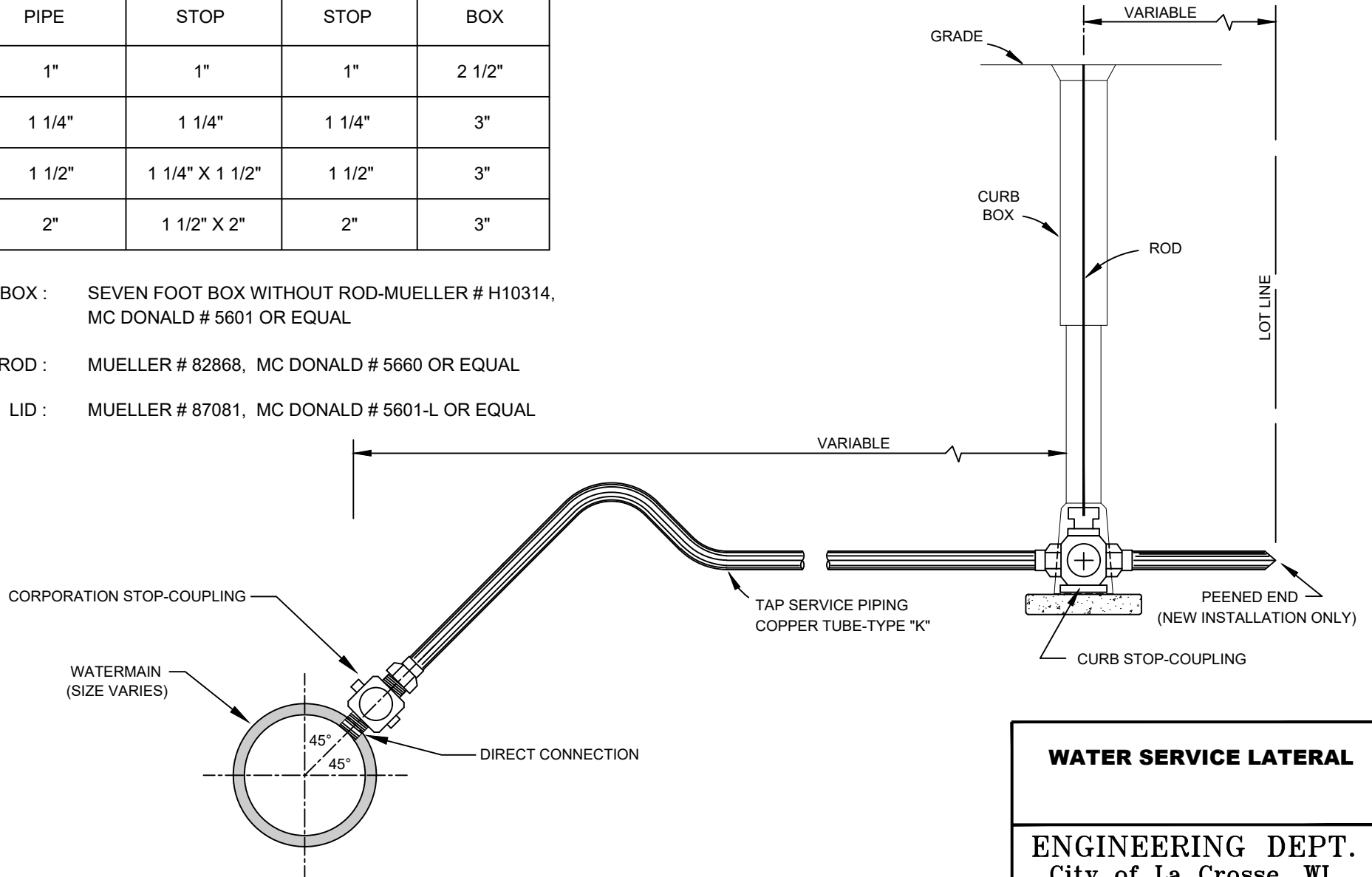

NOTE:

SERVICES 2" OR SMALLER ARE TO BE TAPPED
45° FROM HORIZONTAL ON WATERMAIN

WATER SERVICE LATERAL

ENGINEERING DEPT.
City of La Crosse, WI.

FIELD BOOK	SURVEYED	BY	DATE
NUMBER	DRAWN	PRELIMINARY	
	DESIGNED	FINAL	
	APPROVED		
PAGE	REVISIONS		01/2021
		JMC	11/2024

DRAWING
NOT TO SCALE

SEWER PIPE JOINT MATERIALS

CONCRETE PIPE-RUBBER GASKET (ASTM C-443)
PVC PIPE-ELASTOMETRIC GASKET (ASTM D-3212 & F-477)

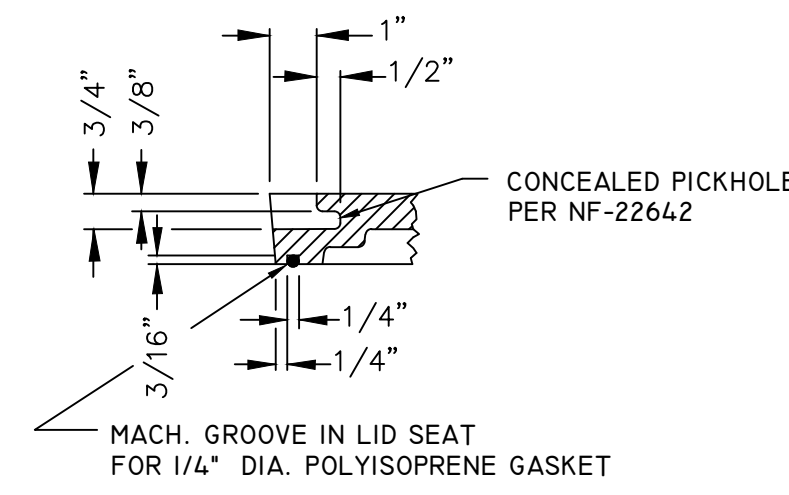
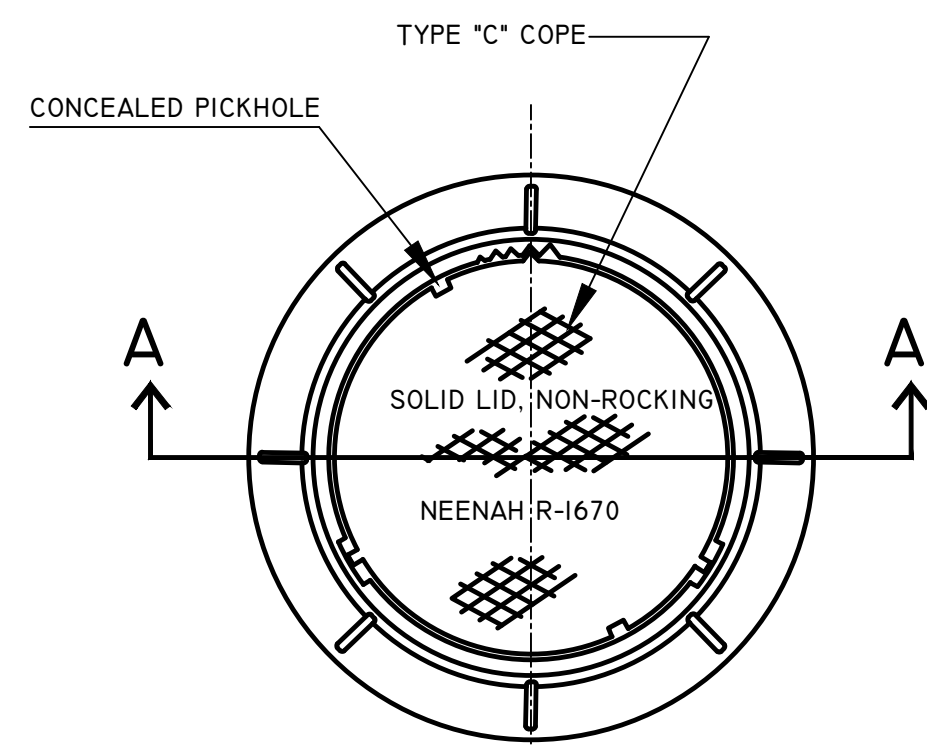

SELF-SEAL DETAIL

NOTE
OPENING FOR FRAME & COVER SHALL BE CENTERED ON MANHOLES WITH FLAT TOPS.

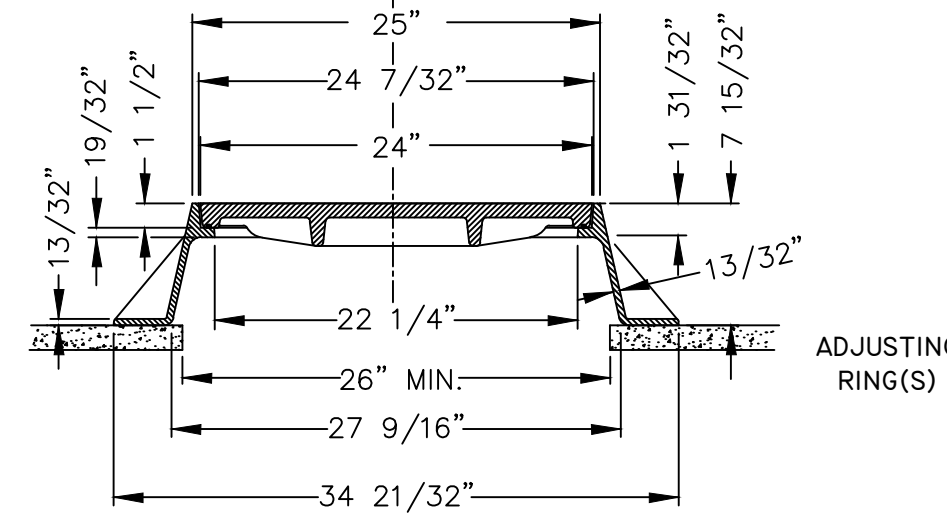

A - A
DETAIL OF MANHOLE FRAME & COVER

(MINIMUM WEIGHT 324 LBS. TOTAL)
NEENAH R-1670 OR EQUAL

B
D-6

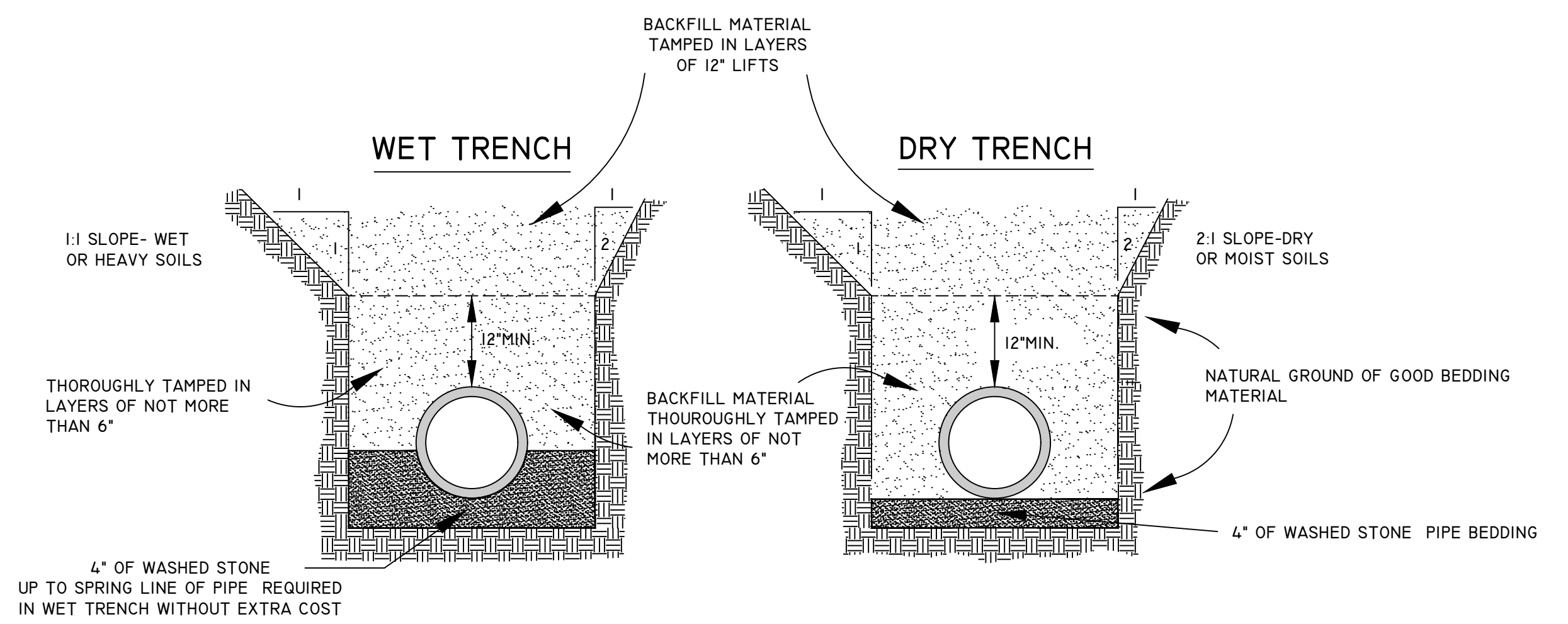
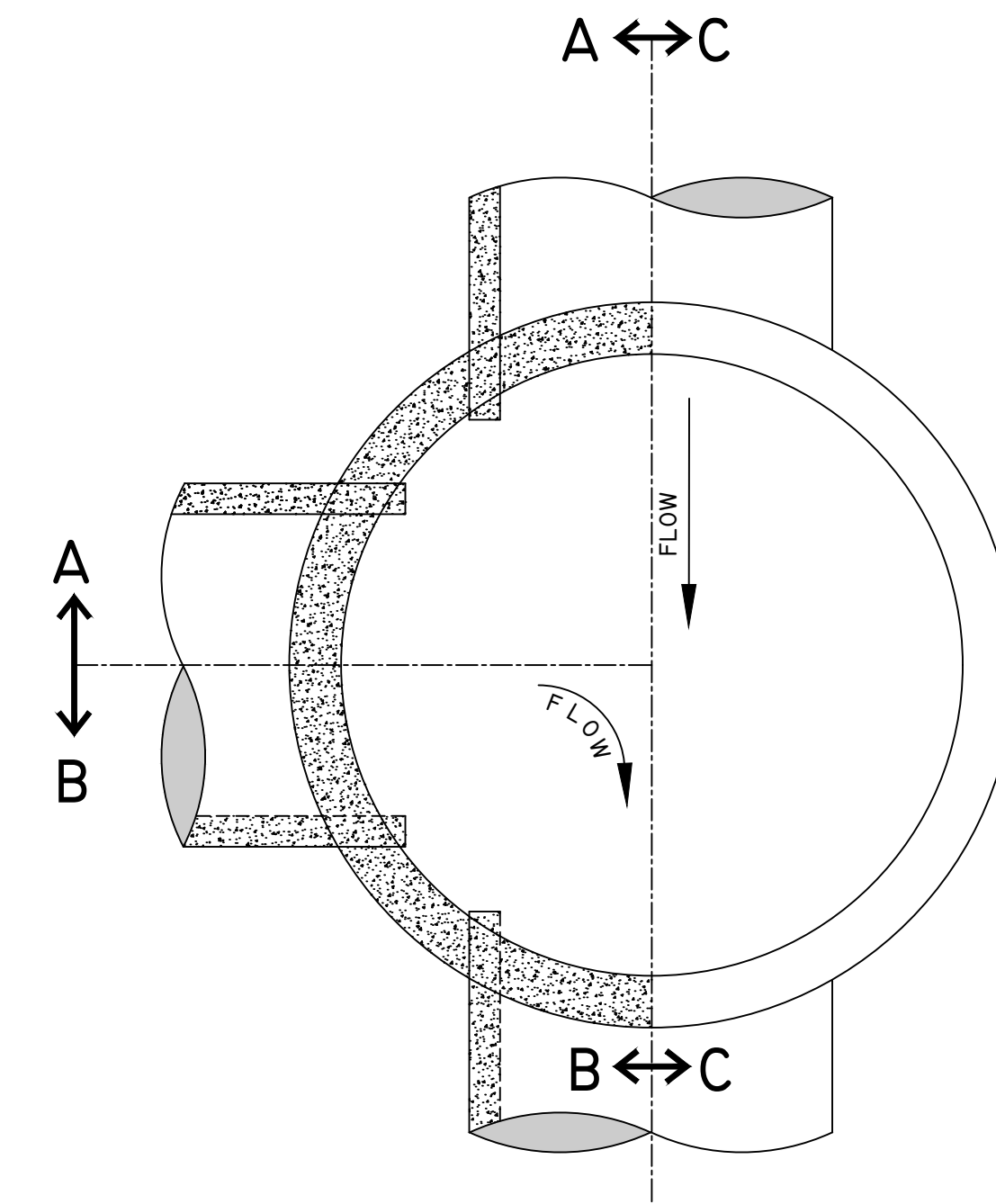
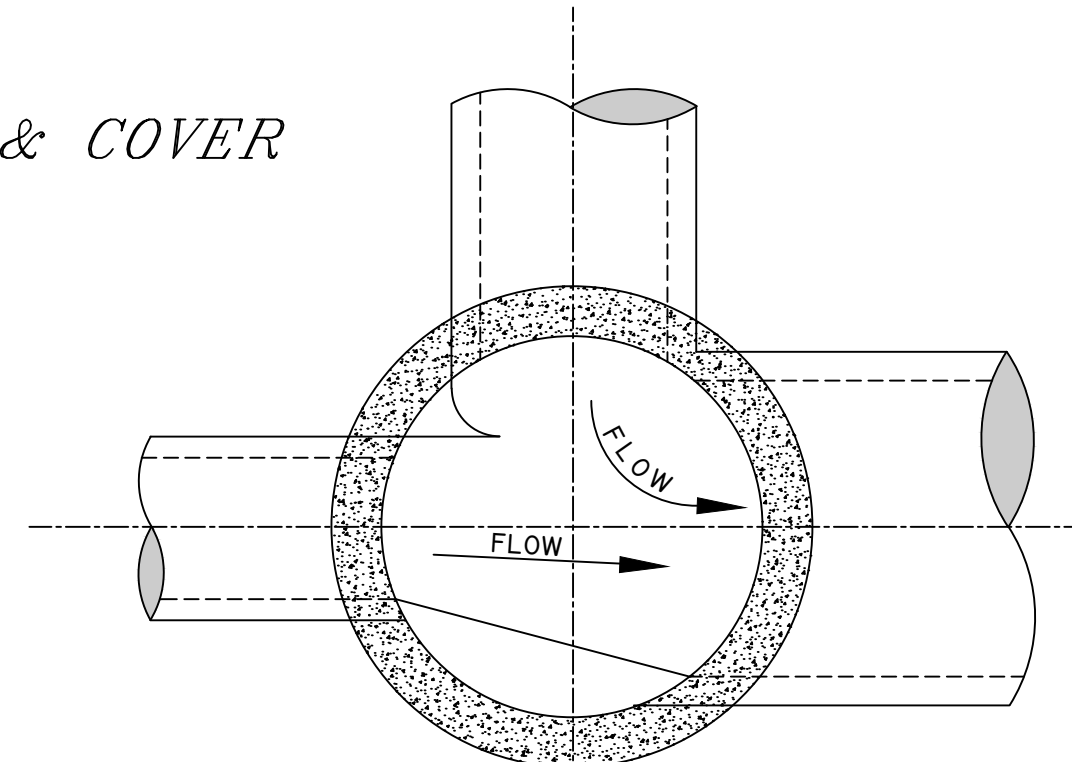

DETAILS OF SEWER TRENCHES

A
D-6

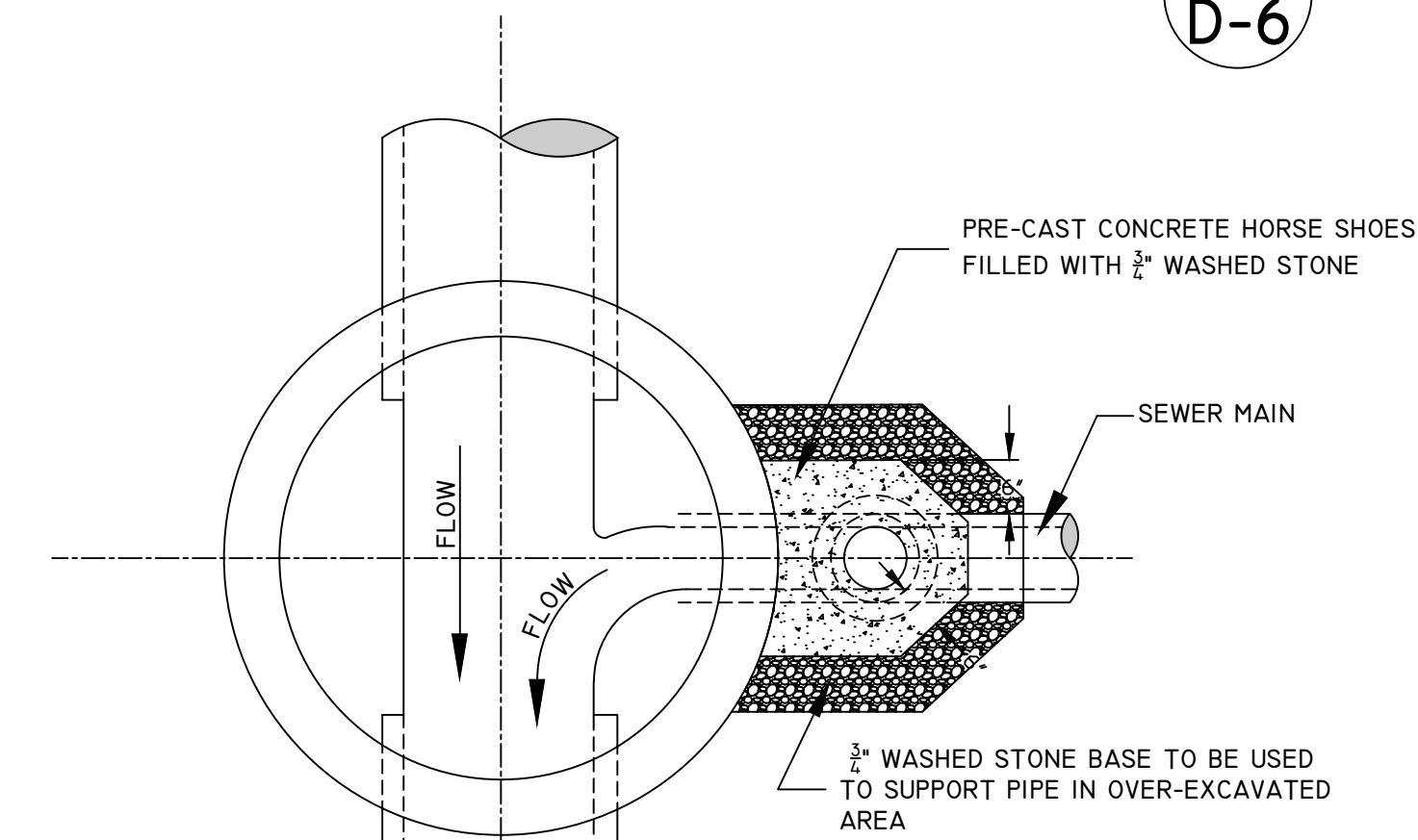

NOTE 11
A DROP MANHOLE SHALL BE PROVIDED FOR A LATERAL SEWER ENTERING A MANHOLE 24" OR MORE ABOVE THE MANHOLE INVERT.

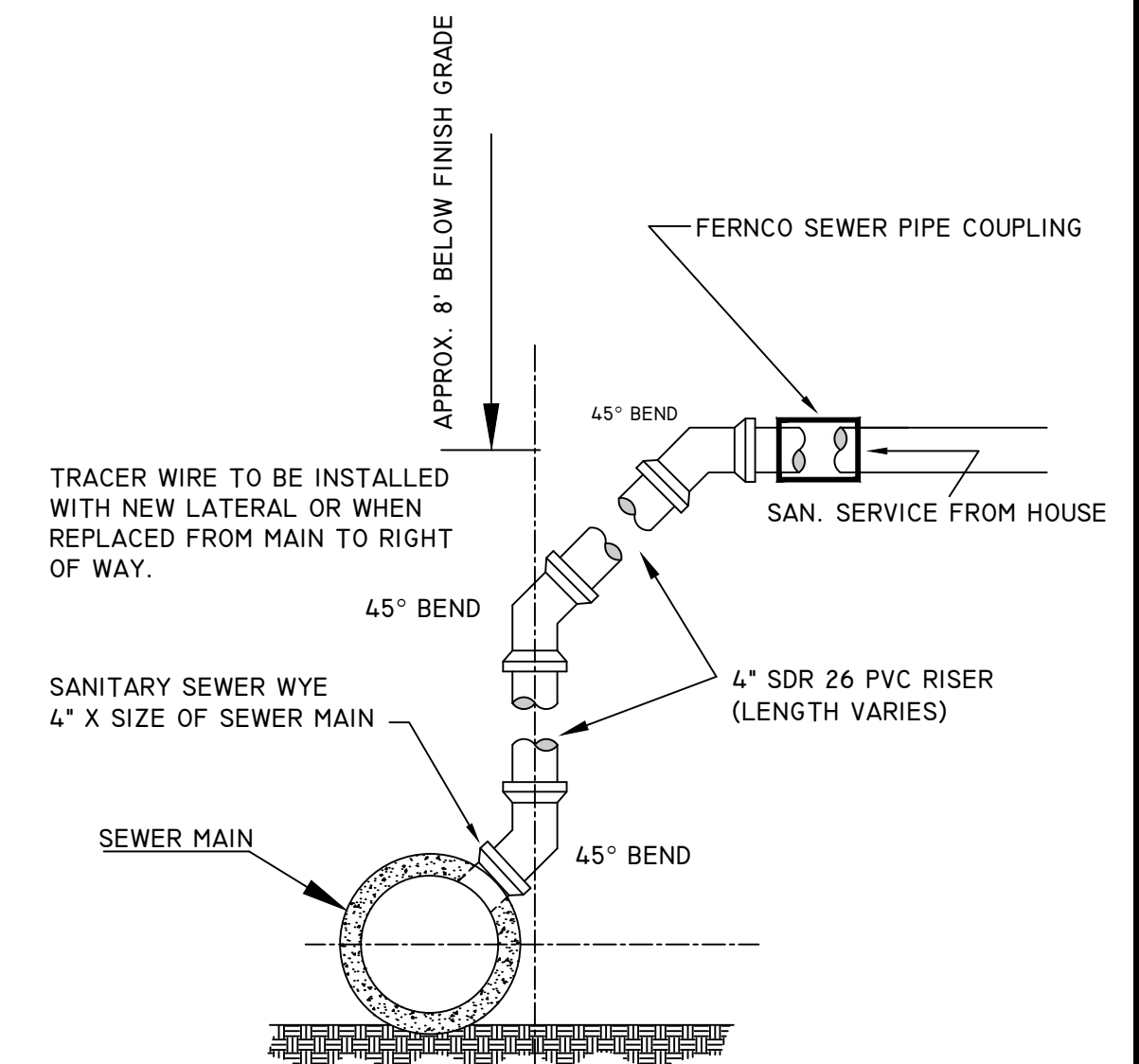

DETAILS OF RISER FOR HOUSE CONNECTION

F
D-6

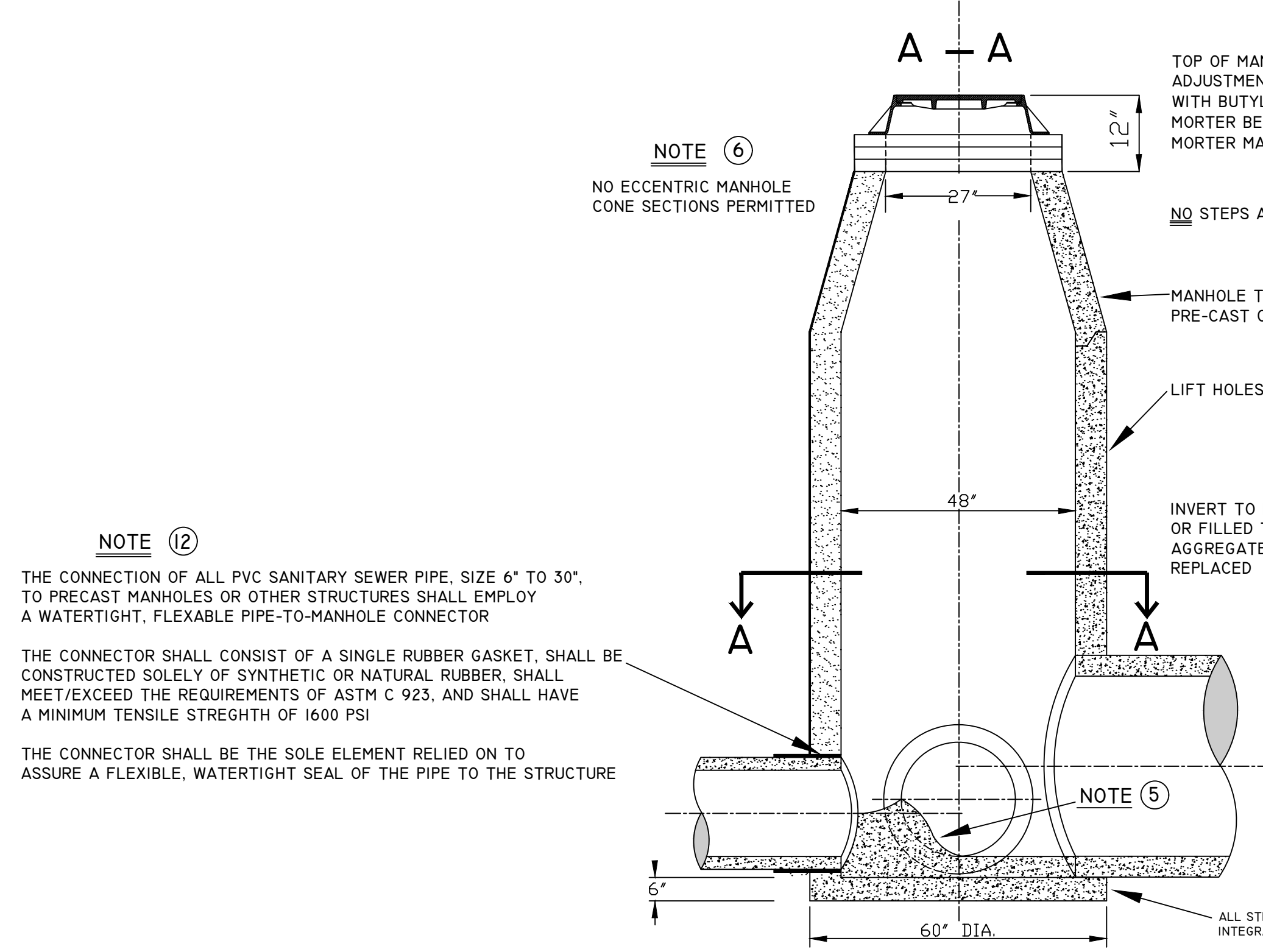

C
D-6 **DETAILS OF STANDARD MANHOLE FOR 30" PIPE OR SMALLER**

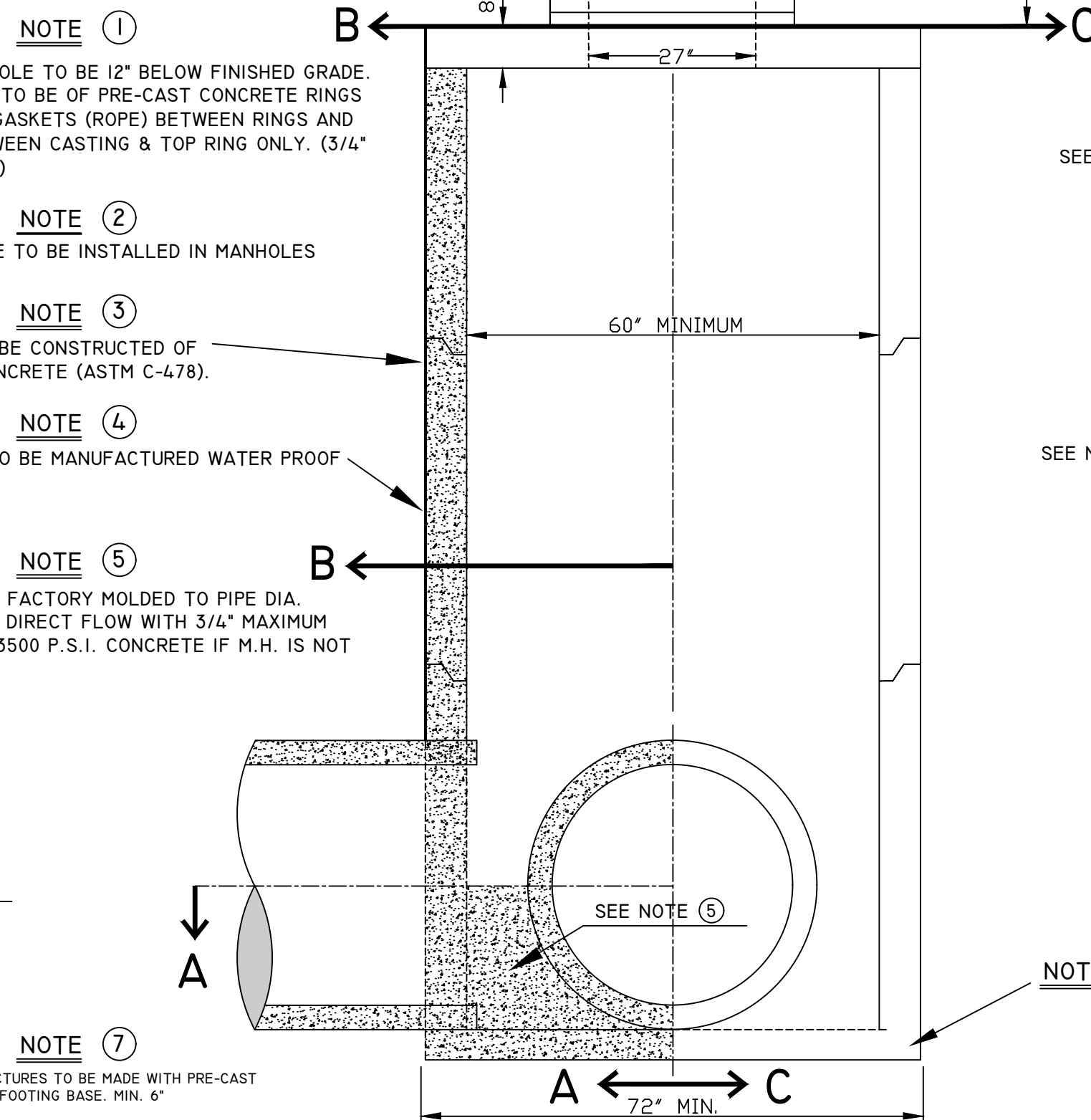

D
D-6 **DETAILS OF STANDARD MANHOLE FOR 36" PIPE OR LARGER**

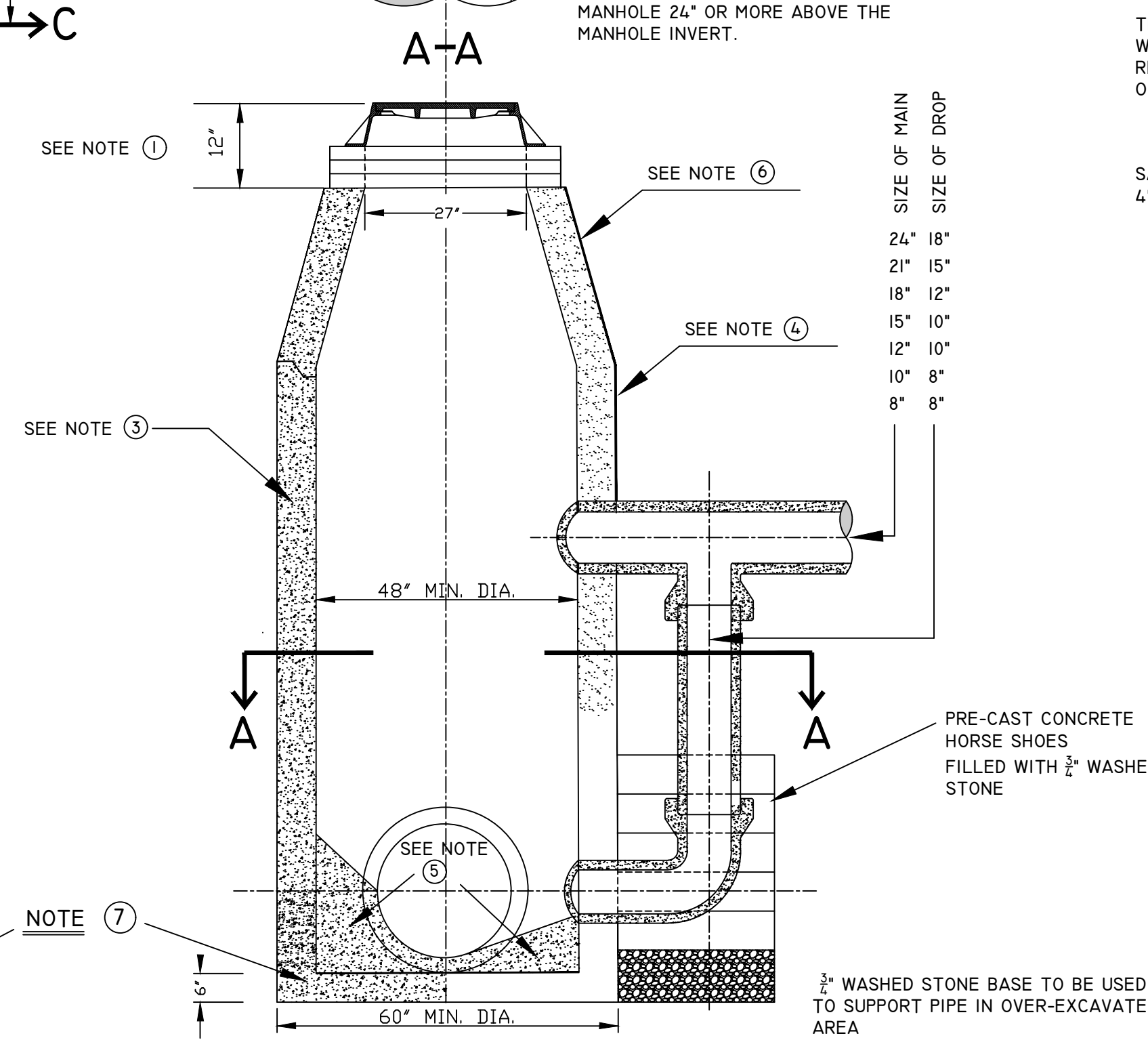

E
D-6 **DETAILS OF DROP MANHOLE FOR 30" PIPE OR SMALLER**

NOTE 12
THE CONNECTION OF ALL PVC SANITARY SEWER PIPE, SIZE 6" TO 30", TO PRECAST MANHOLES OR OTHER STRUCTURES SHALL EMPLOY A WATERTIGHT, FLEXIBLE PIPE-TO-MANHOLE CONNECTOR.
THE CONNECTOR SHALL CONSIST OF A SINGLE RUBBER GASKET, SHALL BE CONSTRUCTED SOLELY OF SYNTHETIC OR NATURAL RUBBER, SHALL MEET/EXCEED THE REQUIREMENTS OF ASTM C 923, AND SHALL HAVE A MINIMUM TENSILE STRENGTH OF 1600 PSI.
THE CONNECTOR SHALL BE THE SOLE ELEMENT RELIED ON TO ASSURE A FLEXIBLE, WATERTIGHT SEAL OF THE PIPE TO THE STRUCTURE.

NOTE 6
NO ECCENTRIC MANHOLE CONE SECTIONS PERMITTED

NOTE 1
TOP OF MANHOLE TO BE 12" BELOW FINISHED GRADE. ADJUSTMENT TO BE OF PRE-CAST CONCRETE RINGS WITH BUTYL GASKETS (ROPE) BETWEEN RINGS AND MORTAR BETWEEN CASTING & TOP RING ONLY. (3/4" MORTAR MAX.)

NOTE 2
NO STEPS ARE TO BE INSTALLED IN MANHOLES

NOTE 3
MANHOLE TO BE CONSTRUCTED OF PRE-CAST CONCRETE (ASTM C-478).

NOTE 4
LIFT HOLES TO BE MANUFACTURED WATER PROOF

NOTE 5
INVERT TO BE FACTORY MOLDED TO PIPE DIA. OR FILLED TO DIRECT FLOW WITH 3/4" MAXIMUM AGGREGATE, 3500 P.S.I. CONCRETE IF M.H. IS NOT REPLACED

NOTE 7
ALL STRUCTURES TO BE MADE WITH PRE-CAST INTEGRAL FOOTING BASE. MIN. 6"

SANITARY SEWER DETAILS
D-6

ENGINEERING DEPT.
City of LaCrosse, Wis.

FIELD BOOK NUMBER	DATE	BY	DATE
DESIGNED			
DRAWN			
CHECKED			
APPROVED			
REVISIONS			
	M.D.F.	3/03	J.M.C.
	J.M.C.	9/03	B.F.M.
	M.D.F.	4/06	J.M.C.
	M.D.F.	12/10	B.F.M.
	M.D.F.	4/13	J.M.C.
			6/2015
			2/2019
			8/2019
			11/2019
			11/2023
			11/2024

SCALE: NONE

Curb Ramps

Construction Guidance

General Construction:

- Curb ramps shall extend at a constant width from landing to back of curb (flares or wings not permitted)
- Curb ramps shall be colinear with sidewalks
- Curb ramps shall maintain alignment with back of sidewalk
- Expansion joint material should be placed along back of curb and/or gutter and near the landing as directed by the engineer or technician

Detectable Warning Surface (DWS):

- Perpendicular DWS - placed transverse to the direction of pedestrian travel and as close to back of gutter as possible
- Radial DWS - must be used when the measurement taken along the longest side of the curb ramp from back of curb to the front edge of the DWS exceeds 5' in length (See detail)
- Rail Crossing DWS - shall be placed directly behind gate if present. When a gate is not present DWS shall not be less than 6 feet or more than 15 feet from rail
- Joints are not permitted to originate / terminate at a DWS

Grades/Slopes:

- Landings must be at or less than 2% by 2% grade/slope
- Ramps must be less than 8.3% longitudinal grade, and at or less than 2% cross slope
- A longitudinal grade greater than 5% can be maintained for not more than 30 feet

Widths/Opening:

- Ramps shall match widths of landing
- Ramps shall be constant width, extending to back of gutter
- Ramps may be narrower than curb openings
- DWSs in ramps shall be edge-to-edge, with a 1" maximum border
- Curb tapers may only be installed when adjacent to turf
- Grade of ramp shall be constant from landing to flowline of gutter
- Vertical curb faces shall be installed when adjacent to hardscape surface and pedestrian curb

Triangular / "Pie" Area Between Ramps:

- If the pie measures greater than 10 square feet, the area must be replaced with turf
- If the pie measures less than 10 square feet, the area must be poured in concrete

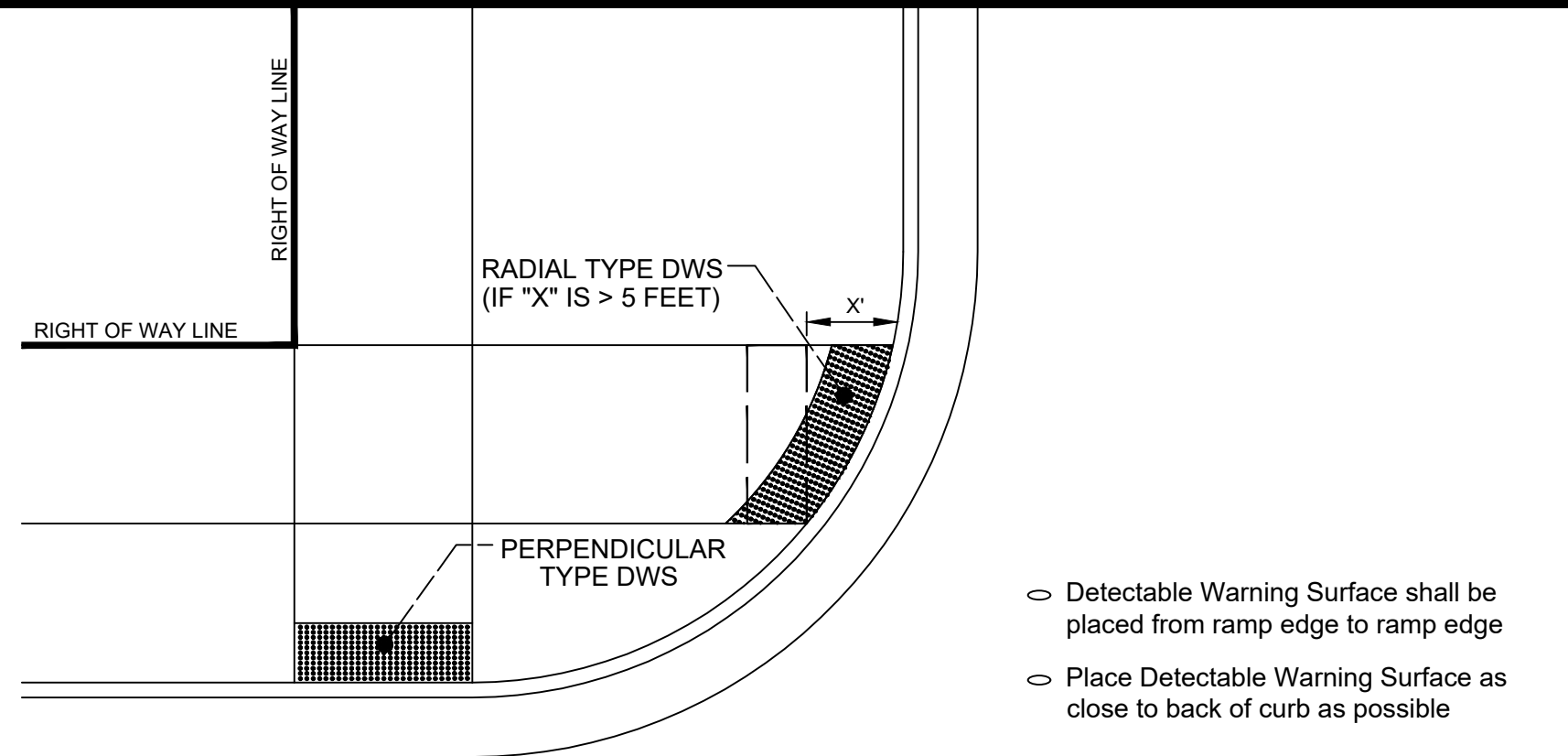

Detectable Warning Surface (DWS)

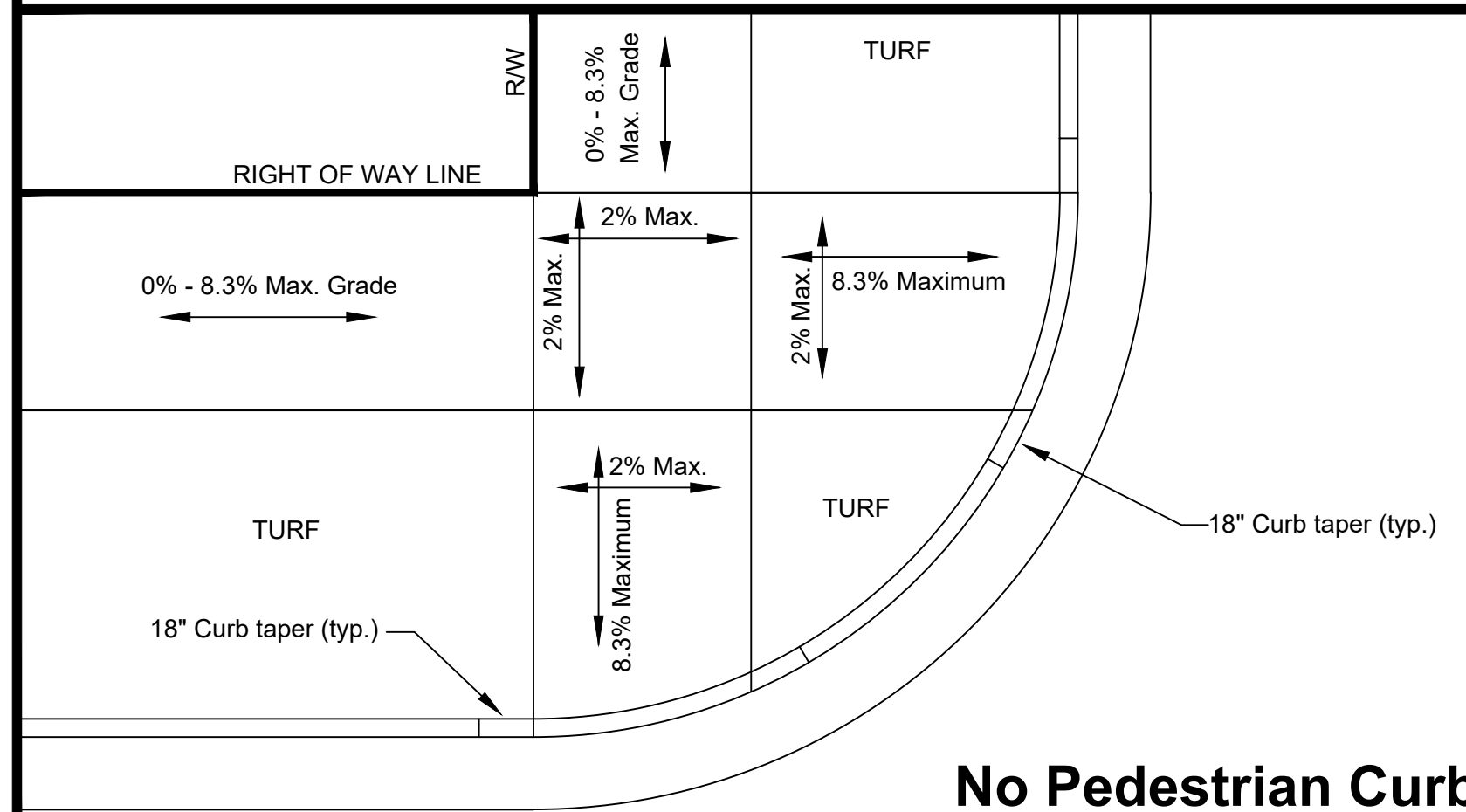

No Pedestrian Curb

Curb Ramps

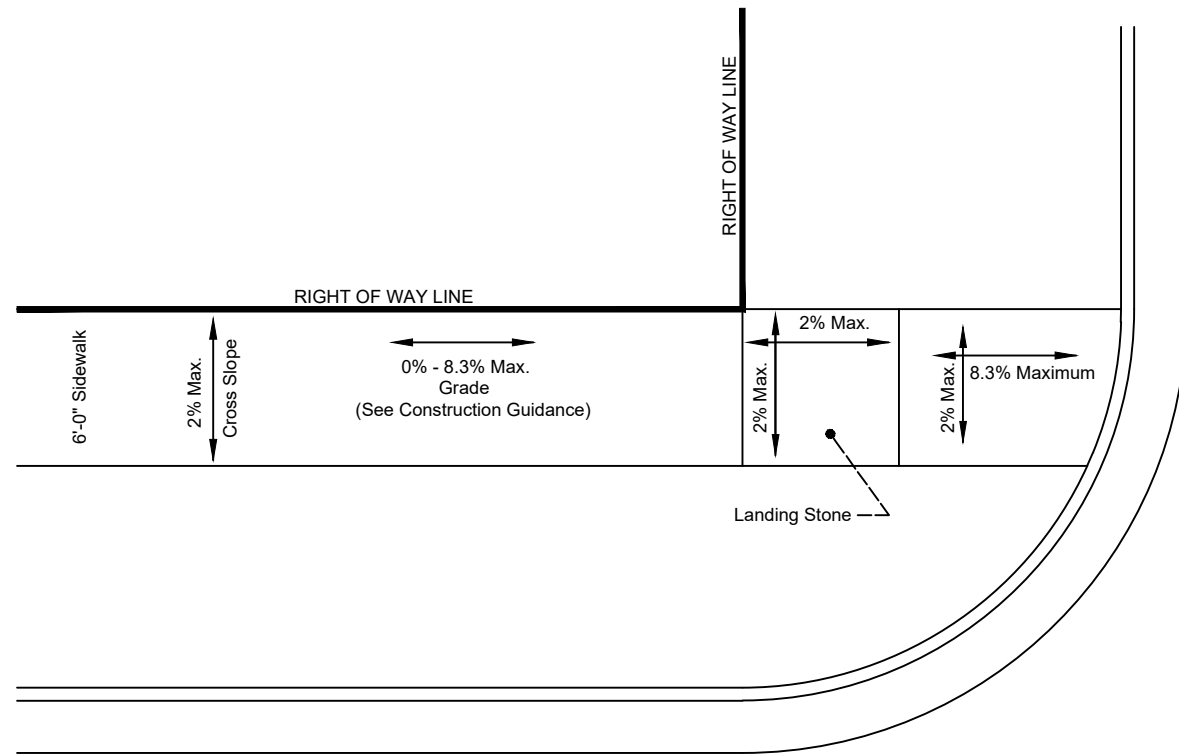

Type 1

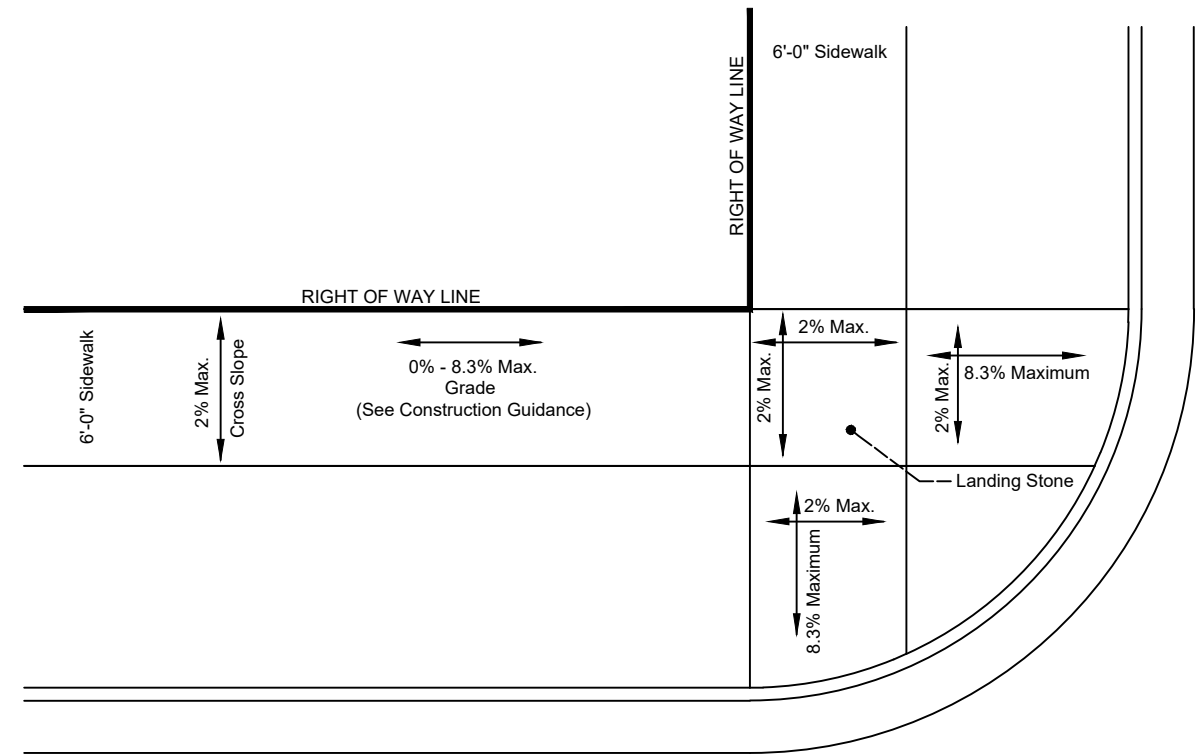

Type 2

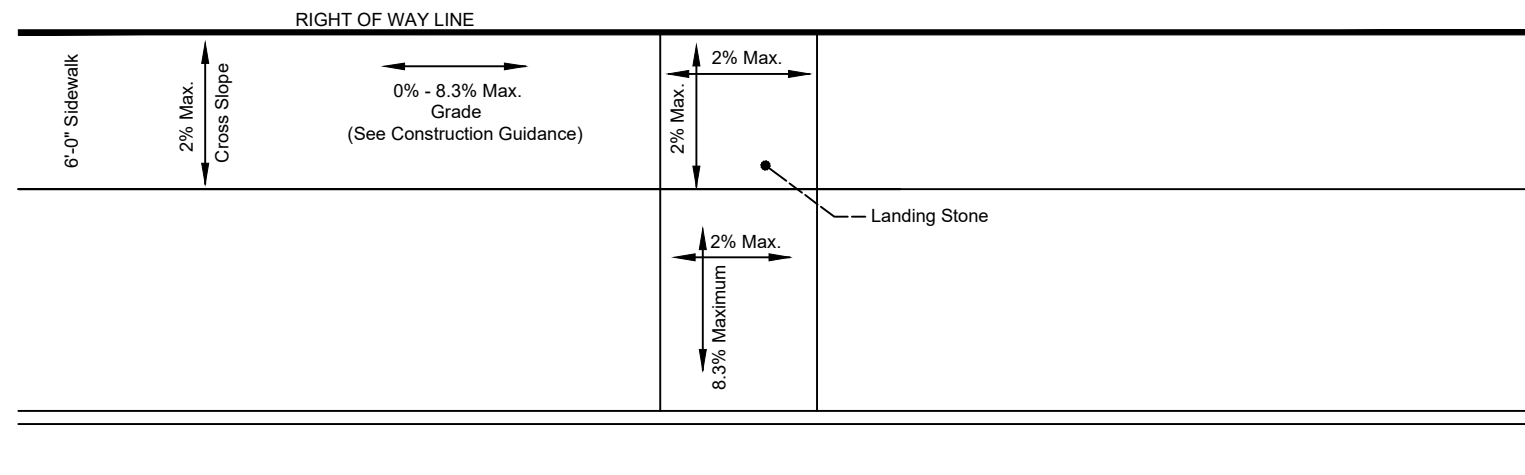

Type 7

Pedestrian Curb

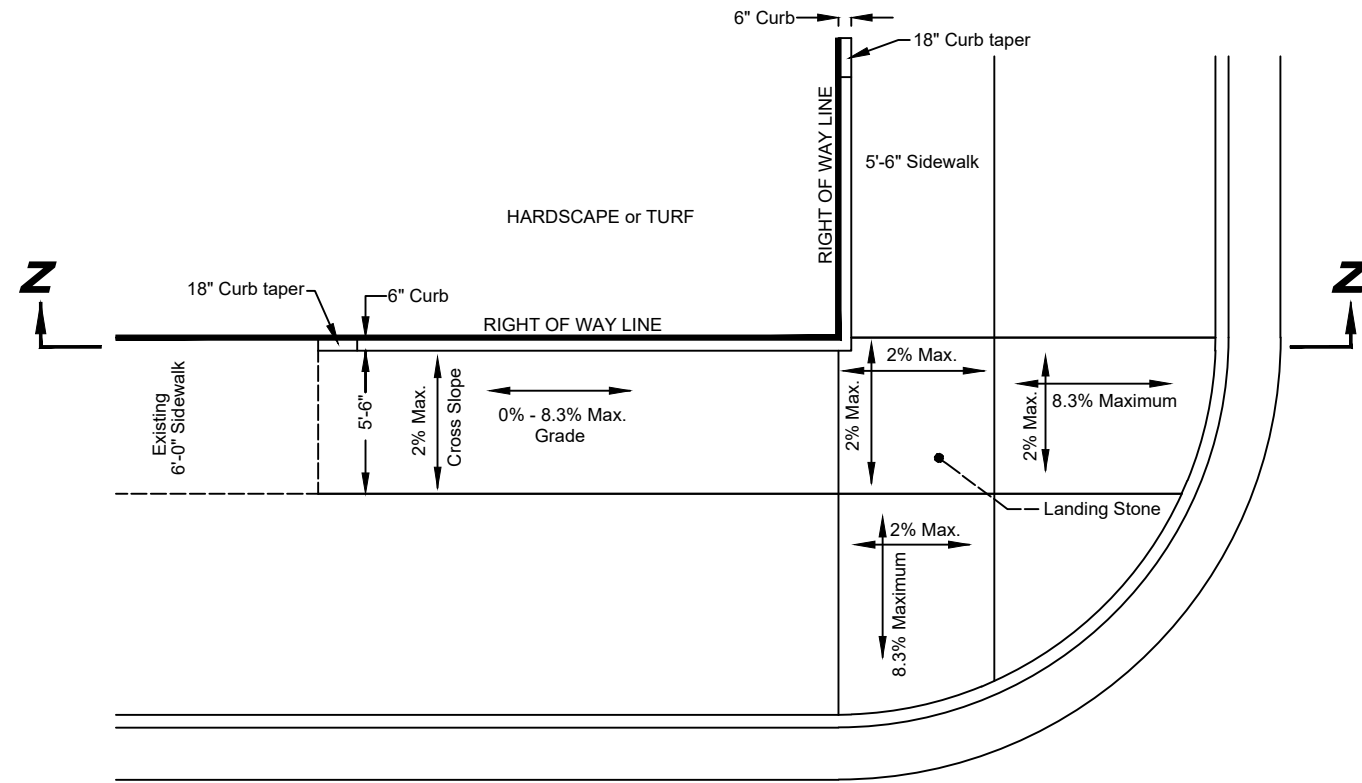

Type A

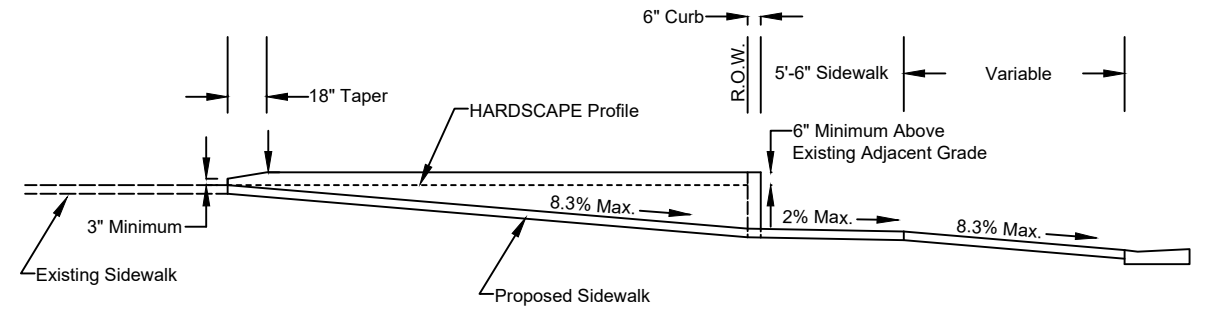

**Section Z-Z
Hardscape**

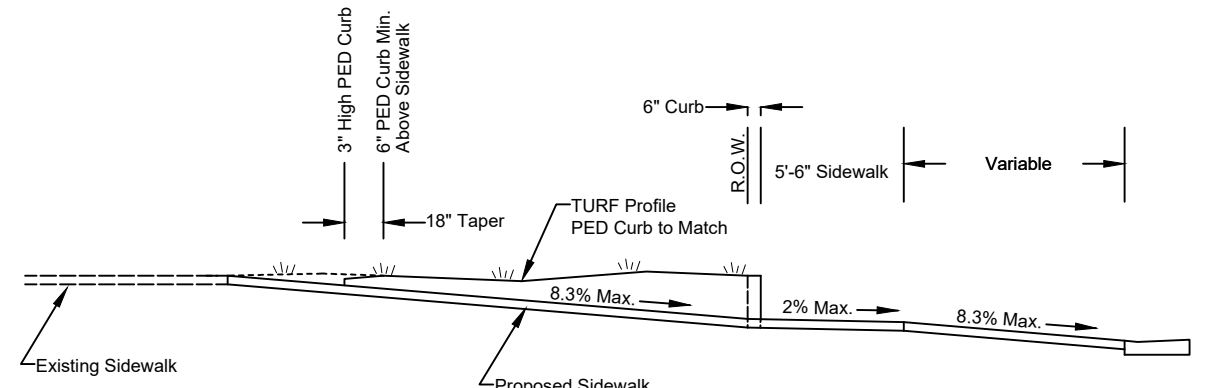

**Section Z-Z
Turf**

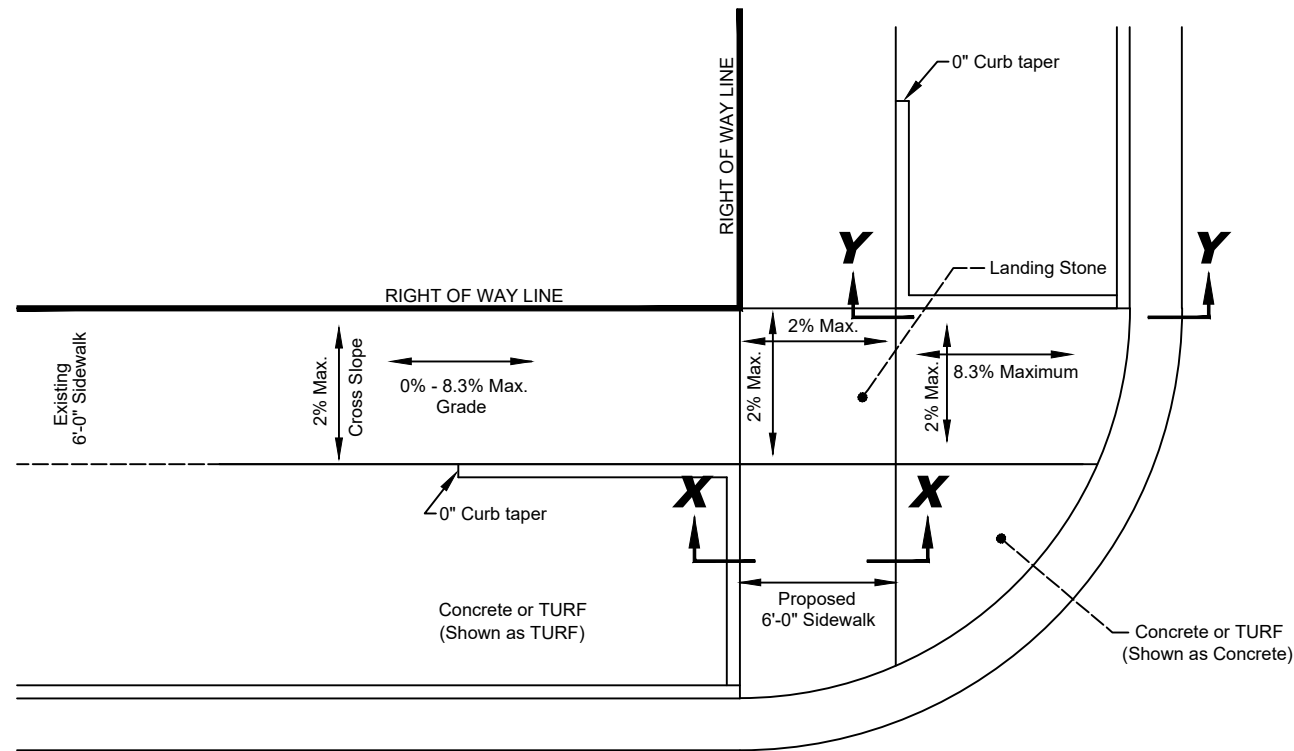

Type B

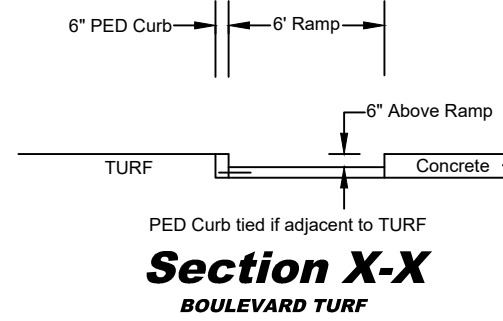

**Section X-X
BOULEVARD TURF**

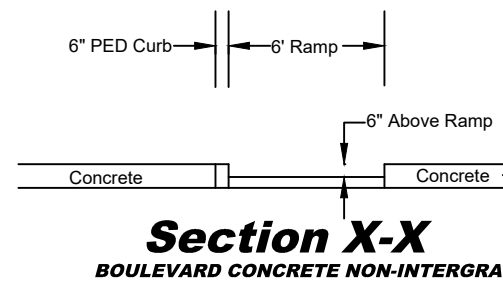

**Section X-X
BOULEVARD CONCRETE NON-INTERGRAL**

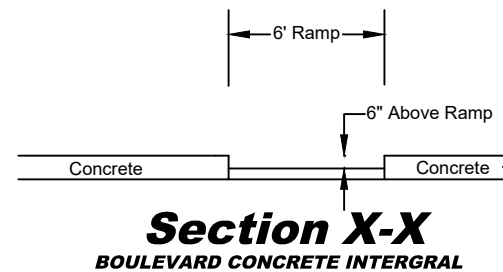

**Section X-X
BOULEVARD CONCRETE INTEGRAL**

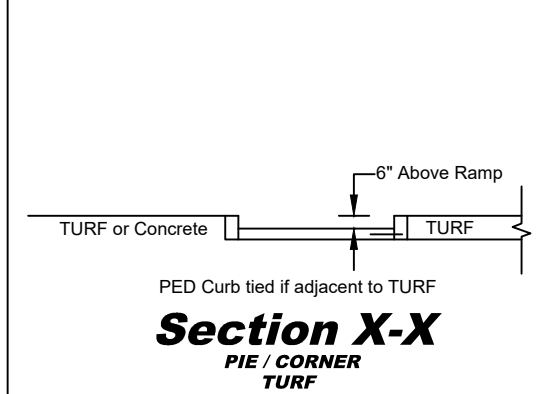

**Section X-X
PIE / CORNER
TURF**

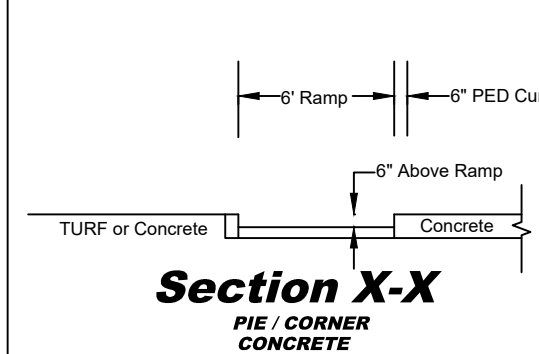

**Section X-X
PIE / CORNER
CONCRETE**

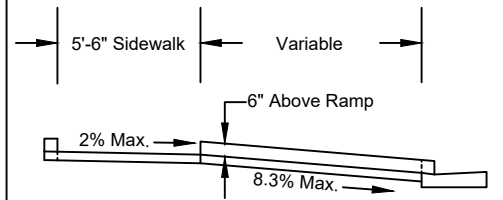

Section Y-Y
(PED Curb tied if adjacent to TURF)

CONTRACT CHANGE ORDER

No. 1

Date 12/4/2024

EDF # 23-006

Contract No. MISC-2024-004 for the following public work: 2023 Signal Fiber Southside Infill between Kramer Well Drilling and the City of La Crosse, dated February 8, 2024, is hereby changed in the following particulars, to-wit:

The following specific work is hereby eliminated from such contract:

Fiber to 16th & Jackson \$ 33,049.60

The following specific work is hereby added to such contract:

Duct cleaning on Mormon Coulee Rd, \$15,575.00

West Ave, and Main St

Duct repair on Mormon Coulee Rd, \$24,803.20

West Ave, and La Crosse St

Additional Drilling on Ward Ave \$ 5,489.36

By virtue of such changes in the contract, the following revisions shall be made:

Contract-----	\$ 309,922.24
Contingency-----	\$ 40,077.76
Net Previous Change Orders-----	\$ _____
Decrease by eliminations (this C.O.)-----	\$ 33,049.60
Increase by additions (this C.O.)-----	\$ 40,378.20
Net Deductions or Additions (Strike out one)-----	\$ 7,328.60
Revised Contract Total -----	\$ 317,250.84

Kramer Well Drilling
NAME OF CONTRACTOR

COO / 12-4-24
CONTRACTOR SIGNATURE

BOARD OF PUBLIC WORKS

I HEREBY CERTIFY that there are sufficient funds in the treasury to meet the liability assumed by the foregoing addenda to contract, or that provision has been made to pay the liability that will accrue thereunder. (WS 62.15-12; 62.09-10-f)

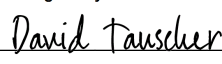
Signed by:

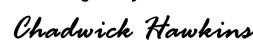
EE923CC8B4BC443... Budget Analyst

DocuSigned by:

A93F306A40954A6... Controller

CONTRACT CHANGE ORDER

No. 3

Date 11/27/2024

EDF # 23-005

Contract No. Curb-2024-003 for the following public work: Hass St – Losey Blvd. to Diagonal Rd. between Fowler & Hammer, Inc. and the City of La Crosse, dated 02/08/2024, is hereby changed in the following particulars, to-wit:

The following specific work is hereby eliminated from such contract:

N/A

The following specific work is hereby added to such contract:

Additional Earthwork Time & Materials

By virtue of such changes in the contract, the following revisions shall be made:

Contract -----	<u>\$545,971.87</u>
Contingency -----	<u>\$ 52,501.08</u>
Net Previous Change Orders -----	<u>\$ 12,858.92</u>
Decrease by eliminations (this C.O.) -----	<u>\$0.00</u>
Increase by additions (this C.O.) -----	<u>\$8,050.00</u>
Net Deductions or Additions (Strike out one) -----	<u>\$ 8,050.00</u>
Revised Contract Total -----	<u>\$566,880.79</u>

Fowler & Hammer, Inc

NAME OF CONTRACTOR

 PM
CONTRACTOR SIGNATURE

BOARD OF PUBLIC WORKS

I HEREBY CERTIFY that there are sufficient funds in the treasury to meet the liability assumed by the foregoing addenda to contract, or that provision has been made to pay the liability that will accrue thereunder. (WS 62.15-12; 62.09-10-f)

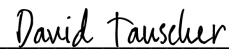
Signed by:

EE923CC8B4BC443... **Budget Analyst**

DocuSigned by:

A93F306A40954A6... **Controller**