

GENERAL STRUCTURAL RACKING NOTES

GENERAL NOTES:

- ALL CONSTRUCTION FOR UNIRAC'S "GROUND FIXED TILT" (GFT) RACKING SYSTEM AND FOUNDATION REQUIREMENTS SHALL CONFORM TO THE 2009, 2012, AND 2015 EDITION OF THE INTERNATIONAL BUILDING CODE (IBC).
- WHEREVER THE TERM CONTRACTOR IS USED IN THE CONSTRUCTION DOCUMENTS, IT SHALL BE DEFINED TO MEAN THE GENERAL CONTRACTOR AND ANY SUB-CONTRACTOR COLLECTIVELY AS APPLICABLE AND AS REQUIRED.
- THE CONTRACT "STRUCTURAL RACKING" DRAWINGS REPRESENT THE FINISHED STRUCTURE. THEY DO NOT INDICATE THE MEANS, METHOD, OR SEQUENCE OF CONSTRUCTION. THE CONTRACTOR SHALL BE RESPONSIBLE FOR AND PROVIDE ALL MEASURES NECESSARY TO PROTECT THE RACKING SYSTEM FROM THE POINT OF MATERIAL DELIVERY THROUGH THE COMPLETION OF CONSTRUCTION. UNIRAC AND THE ENGINEER OF RECORD WILL NOT BE RESPONSIBLE FOR THE CONTRACTOR'S MEANS, METHODS, TECHNIQUES, SEQUENCES OR PROCEDURES OF CONSTRUCTION. UNIRAC AND THE ENGINEER OF RECORD WILL NOT BE RESPONSIBLE FOR CONSTRUCTION SITE SAFETY, OR SAFETY PRECAUTIONS AND PROGRAMS INCIDENT HERETO.
- IT IS THE CONTRACTOR'S RESPONSIBILITY TO INSPECT AND ENSURE THAT ALL WORK IS IN CONFORMANCE WITH THE CONTRACT DOCUMENTS. ANY STRUCTURAL INSPECTION/OBSERVATION PROVIDED BY OTHERS DOES NOT RELIEVE THE CONTRACTOR OF THIS RESPONSIBILITY.
- ANY DEVIATIONS FROM THE CONTRACT DOCUMENTS THAT ARE ENCOUNTERED AT A LATER DATE AND ARE DECLARED TO BE SIGNIFICANT BY THE RACKING DISTRIBUTOR SHALL BE CORRECTED BY THE CONTRACTOR (AT THE CONTRACTOR'S EXPENSE).
- CONTRACTOR SHALL VERIFY ALL DIMENSIONS AND COORDINATE SITE CONDITIONS WITH THESE DRAWINGS PRIOR TO BIDDING OR THE START OF CONSTRUCTION. ANY CONFLICTS, DISCREPANCIES, OR OMISSIONS SHALL BE RESOLVED THROUGH YOUR RACKING DISTRIBUTOR PRIOR TO PROCEEDING.
- DO NOT SCALE OFF OF THESE DRAWINGS. WRITTEN DIMENSIONS SHALL BE USED OR WHERE NO DIMENSION IS PROVIDED. CONSULT WITH YOUR RACKING DISTRIBUTOR FOR CLARIFICATION BEFORE PROCEEDING WITH THE BID OR THE WORK.
- IT IS THE CONTRACTOR'S RESPONSIBILITY TO ENSURE THAT THE EQUIPMENT AND INSTALLATION PROCESS (MEANS AND METHODS) ARE APPROPRIATE FOR THE FOUNDATIONS AND THAT THE PILES ARE INSTALLED TO THE SPECIFIED TOLERANCES. UNIRAC IS NOT RESPONSIBLE FOR DAMAGED AND/OR OUT-OF-TOLERANCE PILES DUE TO IMPROPER INSTALLATION EQUIPMENT AND METHODS.
- WHERE ANY DISCREPANCIES OCCUR BETWEEN PLANS, DETAILS, STRUCTURAL NOTES AND SPECIFICATIONS, THE GREATER (MOST CONSERVATIVE) REQUIREMENTS SHALL GOVERN. WHERE NO SPECIFIC DETAIL IS SHOWN, CONSTRUCTION SHALL CONFORM TO SIMILAR WORK ON THE PROJECT, OR IF THERE IS NO SIMILAR WORK, THEN CONSTRUCTION SHALL CONFORM TO INDUSTRY STANDARDS. CONTRACTOR MUST INFORM UNIRAC OF ANY DISCREPANCIES.
- REFER TO SITE PLAN, PILE LAYOUT DRAWING, ELECTRICAL DRAWINGS AND/OR OTHER CIVIL DRAWINGS FOR SPECIFIC PILE LOCATIONS, NORTH-SOUTH PILE SPACING, LOCATION AND DETAILS OF CURBS, INVERTER/EQUIPMENT PADS, TRENCHING/CONDUIT LOCATIONS, JUNCTION BOXES, SITE WORK ITEMS, ETC. AND DIMENSIONS NOT SHOWN ON STRUCTURAL RACKING DRAWINGS.
- CONTRACTOR SHALL INVESTIGATE THE SITE DURING CLEARING AND EARTHWORK OPERATIONS FOR FILLED EXCAVATIONS OR BURIED STRUCTURES, SUCH AS CESSPOOLS, CISTERNS, FOUNDATIONS, ETC.
- ASTM SPECIFICATIONS ON THE DRAWINGS SHALL BE OF THE LATEST ASTM STANDARD SPECIFICATION.
- ANY ENGINEERING DESIGN PROVIDED BY OTHERS AND SUBMITTED FOR REVIEW SHALL BEAR THE SEAL OF A PROFESSIONAL CIVIL OR STRUCTURAL ENGINEER REGISTERED IN THE STATE OF THE LOCAL JURISDICTION.
- THE FOLLOWING DESIGN CRITERIA IS EXCLUDED FROM THE RACKING AND FOUNDATION DESIGN: FLOOD LOADING, DEBRIS LOADING, DYNAMIC ANALYSIS, ACTS OF GOD (TORNADO, HURRICANE, WATER INUNDATION LOADING, ETC.), EROSION, EXPANSIVE SOILS, FROST HEAVE, SOIL LIQUEFACTION, DYNAMIC LOADING FROM SEISMIC EVENTS AND CONDITIONS. IF REQUIRED, THESE SERVICES CAN BE PERFORMED AT AN ADDITIONAL EXPENSE TO THE CLIENT.
- DESIGN CRITERIA PER ASCE 7-05 OR ASCE 7-10:
DESIGN WIND SPEED = VARIES (SEE STATE SPECIFIC LETTER)
GROUND SNOW LOAD = VARIES (SEE STATE SPECIFIC LETTER)
ICE THICKNESS = VARIES (SEE STATE SPECIFIC LETTER)
ICE LOAD WIND SPEED = VARIES (SEE STATE SPECIFIC LETTER)
SEISMIC S_s = VARIES (SEE STATE SPECIFIC LETTER)
SEISMIC S₁ = VARIES (SEE STATE SPECIFIC LETTER)
SOIL SITE CLASS = D
WIND EXPOSURE CATEGORY = B OR C (SEE LETTER)
HURRICANE ZONE = SEE LETTER
OCCUPANCY CATEGORY = SEE LETTER
MINIMUM OF 20' OFFSET FROM NEAREST ADJACENT BUILDING (TO AVOID SNOW DRIFT.)
IMPORTANCE FACTORS BASED ON OCCUPANCY CATEGORY I OR CATEGORY II FOR CALIFORNIA.
*DESIGN WIND PRESSURES PER ASCE 7-05, SECTION 6.5.13, "WIND LOADS ON OPEN BUILDINGS WITH MONOSLOPE, PITCHED OR TROUGHED ROOFS", AND SECTION 6.5.13.3, "COMPONENTS AND CLADDING" FOR MONOSLOPE FREE ROOFS OR ASCE 7-10, SECTION 27.4.3, "WIND LOAD ON OPEN BUILDING WITH MONOSLOPE, PITCHED OR TROUGHTED ROOFS", AND SECTION 30.8.2, "COMPONENTS AND CLADDING" FOR MONOSLOPED PITCHED OR TROUGHED ROOFS.
- SOLAR REQUIREMENTS (FROM OWNER)
- CORROSION PROTECTION REQUIREMENTS:
COLD-FORMED STEEL MEMBERS = G180 MINIMUM (ASTM A653)
HARDWARE = STAINLESS STEEL/DELTA PROTEKT
- ABOVE GRADE CORROSION PROTECTION WILL SUFFICE FOR MOST ENVIRONMENTAL CONDITIONS. BELOW GRADE CORROSION PROTECTION WILL SUFFICE FOR MOST SOILS WITH RESISTIVITY VALUES GREATER THAN 10,000 OHM/CM. IT IS THE OWNER'S RESPONSIBILITY TO DETERMINE IF THE SOILS ARE MORE CORROSIVE AND FURTHER CORROSION PROTECTION WILL BE REQUIRED.
- THE DGFT BILL OF MATERIAL (BOM) TOOL GIVES THE OPTION FOR IDEAL OR OPTIMIZED TABLE DESIGN. IDEAL USES ONLY FULL LENGTH EAST-WEST ALUMINUM BEAMS TO COMPLETE A TABLE AND EXCESS MATERIAL CAN BE CUT AND DISCARDED. OPTIMIZED TABLE DESIGNS UTILIZE LONGER BEAMS TO COMPLETE THE THIRD OR FOURTH EAST-WEST BEAM WITH AN ADDITIONAL SPLICE. REGARDLESS OF THE TABLE DESIGN USED, IT IS THE CONTRACTOR'S RESPONSIBILITY TO SPICE EAST-WEST BEAMS (AS REQUIRED) TO COMPLETE THE TABLE AND AVOID SPLICE CONFLICTS SPECIFIED IN DETAIL 502 ON SHEET SD-500.

- SPECIAL INSPECTION:**
STRUCTURAL ONLY: SPECIAL INSPECTION IS TO BE PROVIDED FOR THE ITEMS LISTED BELOW IN ADDITION TO THE INSPECTIONS CONDUCTED BY THE BUILDING JURISDICTION. "SPECIAL STRUCTURAL INSPECTION" SHALL NOT RELIEVE THE OWNER OR THEIR AGENT FROM REQUESTING THE BUILDING JURISDICTION INSPECTIONS REQUIRED.
- DRIVEN DEEP ELEMENTS: PERIODICALLY DURING THE PLACEMENT OF ALL DRIVEN DEEP FOUNDATION ELEMENTS ON STRUCTURAL DRAWINGS.
 - VERIFICATION OF ELEMENT MATERIALS, SIZES AND LENGTHS.
 - PERIODIC OBSERVATION AND DOCUMENTATION OF DRIVING OPERATIONS. PERIODIC DEFINED AS AT LEAST ONE VISIT ON EACH DAY OF WORK. A MINIMUM OF 10% OF PILE INSTALLATIONS SHALL BE INSPECTED.

- C. VERIFICATION OF PLACEMENT LOCATIONS AND PLUMBNESS, SIZE AND TYPE OF HAMMER, ELEVATION OF TIP AND BUTT, ANY DAMAGE TO FOUNDATION ELEMENT, ETC.
- HIGH STRENGTH BOLTING: VERIFICATION OF TORQUE PER TORQUE TABLE SHOWN.

ALUMINUM:

- ALL ALUMINUM EAST-WEST BEAM MEMBERS HAVE BEEN DESIGNED IN ACCORDANCE WITH THE "ALUMINUM DESIGN MANUAL" BY THE ALUMINUM DESIGN ASSOCIATION, CURRENT ADDITION.
- ALL ALUMINUM EAST-WEST BEAMS CONFORM TO ONE OF THE FOLLOWING:
ALLOY: 6005A TEMPER: T61 (F_{tu} = 38 KSI, F_{cy} = 35 KSI)
ALLOY: 6351 TEMPER: T5 (F_{tu} = 38 KSI, F_{cy} = 35 KSI)
ALLOY: 6061 TEMPER: T6 (F_{tu} = 38 KSI, F_{cy} = 35 KSI)
- ALL ALUMINUM EAST-WEST BEAMS HAVE A MILL FINISH.
- WELDING IS NOT REQUIRED OR PERMITTED UNLESS SPECIFICALLY APPROVED BY UNIRAC AND THE ENGINEER OF RECORD.
- FIELD CUTTING OF ALUMINUM MEMBERS IS PERMITTED WHEN REQUIRED TO ACCOMMODATE PROJECT SPECIFIC MODULE WIDTHS.

HARDWARE:

- ALL 1/4"Ø HARDWARE SHALL CONFORM TO 18/8 STAINLESS STEEL (AISI 300 SERIES STAINLESS, 304) OF DIMENSIONS PER ASME B18.2.1.
- ALL 1/4"Ø SELF DRILLING SCREW HARDWARE SHALL CONFORM TO GRADE 5 SAE J429 AND ASTM A449.
- ALL 5/8"Ø AND 3/4"Ø BOLTS SHALL CONFORM TO GRADE 2 SAE J429 OR ASTM A307.
- ALL 5/8"Ø AND 3/4"Ø SERRATED FLANGE NUTS SHALL CONFORM TO ASME B.18.16.4.
- ALL 5/8"Ø AND 3/4"Ø WASHERS SHALL CONFORM TO USS TYPE A WIDE OR ANSI TYPE A WIDE.
- UNIRAC T-BOLTS, MID CLAMPS, AND END CLAMPS ARE PROPRIETARY. TECHNICAL DATA SHEETS WITH TESTED CAPACITIES CAN BE PROVIDED UPON REQUEST.
- CORROSION PROTECTION FOR HARDWARE CAN BE FOUND IN THE GENERAL NOTES SECTION OF THIS DOCUMENT, NOTE 15.
- ALL HARDWARE RECEIVED ON SITE SHALL BE CHECKED BY CONTRACTOR AGAINST THE SPECIFICATIONS ON THIS SHEET SD-100, DIAMETERS AND LENGTHS CALLED OUT ON RACKING DETAILS SHEET SD-500, AS WELL AS THE PROJECT BILL OF MATERIAL. ANY CONFLICTS, DISCREPANCIES, OR OMISSIONS MUST BE RESOLVED WITH THE RACKING DISTRIBUTOR AS SOON AS POSSIBLE AND PRIOR TO PROCEEDING.

TORQUE REQUIREMENTS FOR THIS SPECIFIC PROJECT:

| | |
|------------------|-----------------|
| 1/4"Ø HARDWARE = | 9 - 11 FT-LBS |
| 5/8"Ø HARDWARE = | 54 - 66 FT-LBS |
| 3/4"Ø HARDWARE = | 99 - 121 FT-LBS |

NOTE: SEE GFT INSTALLATION GUIDE FOR SYSTEM ADJUSTMENTS AND TOLERANCES

UNIRAC GFT

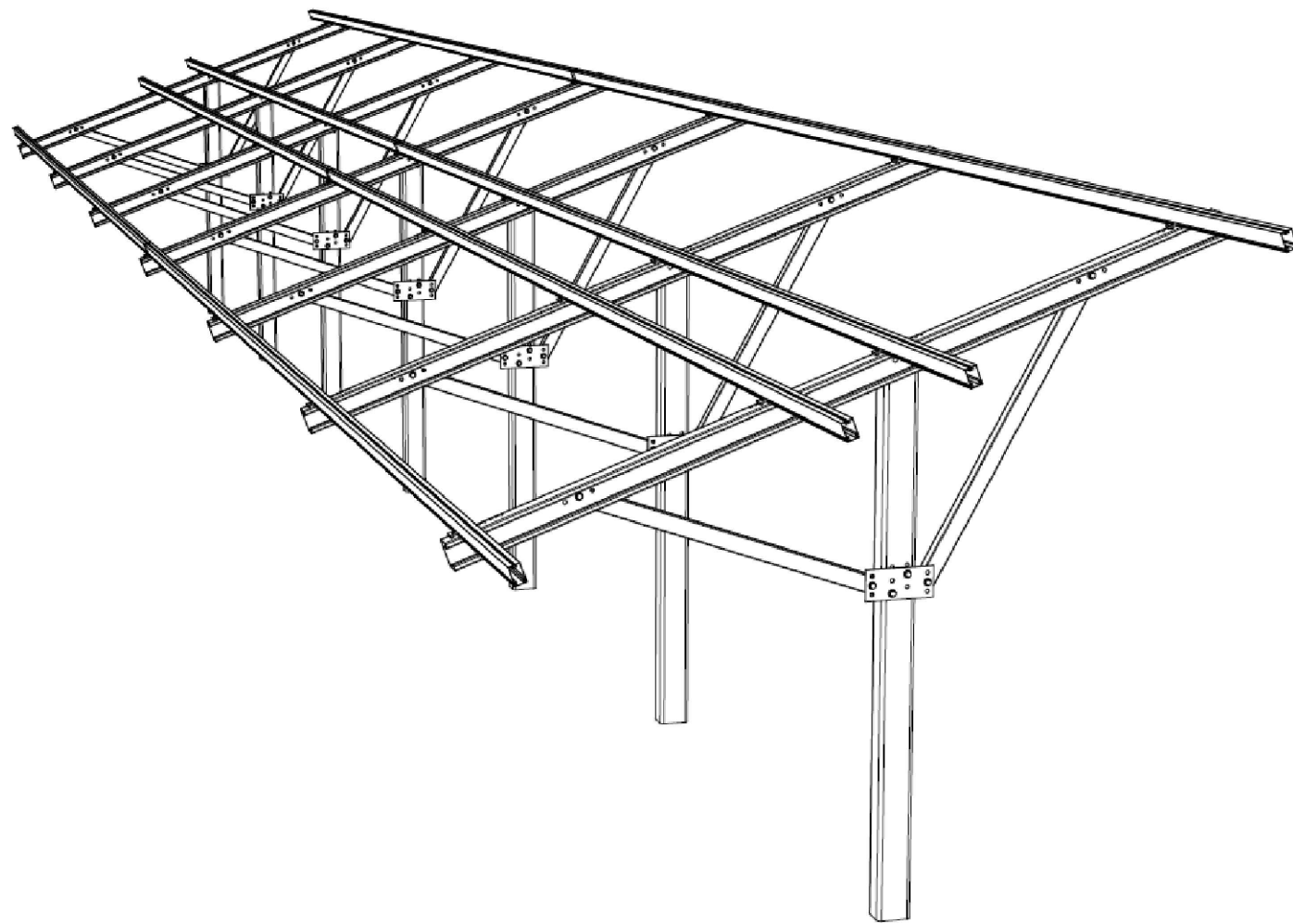

GROUND FIXED TILT

DRIVEN STEEL PILE NOTES:

- STEEL PILES HAVE BEEN DESIGNED IN ACCORDANCE WITH THE DESIGN CRITERIA STATED IN THE GENERAL NOTES.
- PILES SHALL BE INSTALLED SO THAT PILE TOLERANCES ARE MET (SEE UNIRAC GFT INSTALLATION GUIDE), AND THE PILE DOES NOT DEFORM EXCESSIVELY. EXCESSIVE DEFORMATION IS DEFINED AS DISTORTION SO THAT THE RACKING CANNOT CONNECT TO THE PILE.
- FOUNDATIONS MUST NOT BE INSTALLED IN ORGANIC SOILS OR IN AREAS WITH GROUND WATER NEAR THE SURFACE.
- IT IS THE OWNER OR CONTRACTORS RESPONSIBILITY TO DETERMINE WHICH FROST ZONE THEIR PROJECT IS LOCATED IN.
- IF PILE REFUSAL IS ENCOUNTERED, AN ALTERNATE FOUNDATION DESIGN ON SHEET SR-400 SHALL BE UTILIZED.
- DRAINAGE SHALL BE DIRECTED AWAY FROM PILES. PILES SHALL NOT BE PLACED IN SWALES, DRAINAGE AREAS OR WHERE WATER MAY BE ALLOWED TO FLOW OR STAND. ALL POSSIBLE EFFORTS SHALL BE MADE TO PREVENT WATER FROM FLOWING OR PONDING AROUND OR NEAR TO THE PILES.
- PILES MAY NOT BE PAINTED PRIOR TO INSTALLATION OF THE RACKING SYSTEM. AFTER INSTALLATION OF THE COMPLETE RACKING SYSTEM, PILES MAY BE PAINTED AT THE CONTRACTORS/CLIENTS DISCRETION. NO ADJUSTMENTS MAY BE MADE AFTER THE PILES HAVE BEEN PAINTED.
- PILES DRIVEN TOO SHALLOW OR TOO DEEP WILL NEED TO BE ALTERED AT THE CONTRACTORS EXPENSE. UNIRAC HAS PROVIDED TOLERANCES IN THE GFT INSTALLATION GUIDE THAT SHALL BE FOLLOWED.
- IT IS THE CONTRACTORS RESPONSIBILITY TO DETERMINE THE MEANS AND METHODS FOR DRIVING PILES. IN ORDER TO MATCH THE PILE INSTALLATION METHOD UTILIZED DURING ONSITE PILE TESTING, THE CONTRACTOR MUST INSTALL PILES UTILIZING A PILE DRIVING RIG WITH A PERCUSSION HAMMER.
- THE RACKING DISTRIBUTOR SHALL NOT BE HELD RESPONSIBLE FOR DAMAGE TO THE PILE AFTER IT ARRIVES TO THE SITE OR THE POINT OF AGREED DROP OFF.
- IF DAMAGE OCCURS WHERE GALVANIZATION IS REMOVED FROM THE PILE, THE PILE SHALL BE TOUCHED UP WITH GALVANIZATION OF EQUAL THICKNESS PRIOR TO INSTALLATION AT THE CONTRACTOR'S EXPENSE.

SOLAR DESIGN:

UNIRAC IS NOT THE SOLAR DESIGN ENGINEER OF RECORD AND IS NOT RESPONSIBLE FOR ANY SOLAR DESIGN, OUTPUT EFFICIENCIES, SHADING, ETC.

ELECTRICAL DESIGN:

UNIRAC IS NOT THE ELECTRICAL ENGINEER OF RECORD AND IS NOT RESPONSIBLE FOR THE ELECTRICAL DESIGN FOR THIS PROJECT. THE UNIRAC GFT RACKING SYSTEM IS CERTIFIED TO UL-2703 WHEN PROPERLY INSTALLED. SEE THE GFT INSTALLATION GUIDE FOR MORE DETAIL.

CIVIL/GRADING/SITE WORK:

UNIRAC IS NOT THE CIVIL ENGINEER OF RECORD FOR THIS PROJECT AND IS NOT RESPONSIBLE FOR ANY SITE, GRADING, OR EROSION CONTROL PLANS.

MATERIAL MANAGEMENT:

PRIOR TO INSTALLATION, ALL MATERIALS MUST BE STORED PROPERLY. THIS MEANS MATERIALS REMAINING IN ONE PLACE FOR MORE THAN ONE WEEK MUST BE IN OPEN AIR CONDITIONS (I.E. UP AND ABOVE THE GROUND AND WATER TABLE). IF TARPS OR OTHER PROTECTIVE COVERS ARE USED, THEN ENDS SHALL BE LEFT OPEN FOR VENTILATION. TIGHT FITTING COVERINGS ARE NOT RECOMMENDED, SINCE THEY CAN TRAP MOISTURE. IF LONG GOODS ARE TO BE STORED HORIZONTALLY FOR MORE THAN ONE WEEK, PLACE BLOCKING OF SUFFICIENT HEIGHT BENEATH THE STACK ON PROPER INTERVALS TO MINIMIZE DEFORMATION AND TO LESSEN MOISTURE GAIN FROM THE GROUND.

FOUNDATION NOTES:

- THE FOLLOWING DESIGN CRITERIA IS EXCLUDED FROM DESIGN: FLOOD LOADING, DEBRIS LOADING, DYNAMIC ANALYSIS, ACTS OF GOD (TORNADO, HURRICANE, WATER INUNDATION LOADING, ETC.), EROSION, EXPANSIVE SOILS, FROST HEAVE, SOIL LIQUEFACTION, SOIL DYNAMIC LOADING FROM SEISMIC EVENTS AND CONDITIONS.
- SEE THE "COLD FORMED STEEL" SECTION FOR STEEL AND GALVANIZATION REQUIREMENTS FOR FOUNDATIONS.
- UNIRAC SHALL NOT BE HELD LIABLE FOR ANY UTILITY LINES DAMAGED DURING FOUNDATION INSTALLATION. IT SHALL BE THE RESPONSIBILITIES OF OTHERS TO DETERMINE THE PLACEMENT OF EXISTING AND NEW UTILITY LINES.
- PILES ARE DESIGNED TO SOIL CONDITIONS STATED IN IBC 2012. IT IS THE CLIENTS RESPONSIBILITY TO VERIFY SOILS MEET THE MINIMUM REQUIREMENTS. UNIRAC AND OR THE ENGINEER OF RECORD WILL NOT BE HELD RESPONSIBLE FOR FOUNDATIONS INSTALLED IN SOILS WITH LOWER CAPACITY OR FOR IMPROPER FOUNDATION INSTALLATION OR CHOICE.

- IT SHALL BE THE CONTRACTORS RESPONSIBILITY TO ENSURE THAT VIBRATIONS FROM DRIVING EQUIPMENT AND PILE INSTALLATION DO NOT AFFECT ANY ADJACENT PROPERTY STRUCTURES. THE CONTRACTOR SHALL BE HELD LIABLE FOR DAMAGE TO THE ADJACENT PROPERTY IF DAMAGE OCCURS.
- ANY EXCAVATIONS NEAR THE PILE SHALL NOT BE MADE CLOSER THAN 3 FEET FROM PILE FACE OR DEEPER THAN 3 FEET FROM GRADE. THESE EXCAVATIONS SHALL BE TEMPORARY AND SHALL BE COMPACTED PER THE ENGINEER OF RECORD'S RECOMMENDATIONS. IF EXCAVATIONS EXCEED THESE DIMENSIONAL REQUIREMENTS FOR FROST HEAVE OR OTHER REASONS, THE CONTRACTOR SHALL NOTIFY UNIRAC. THE ENGINEER OF RECORD SHALL BE INFORMED OF ANY EXCAVATION AND COMPACTION EFFORTS ON THE SITE.
- PILES MAY NOT BE ALTERED IN ANY WAY WITHOUT UNIRAC WRITTEN APPROVAL. PILES HAVE BEEN DESIGNED FOR STATIC LOADING. ABOVE GRADE PILES HAVE BEEN ANALYZED STATICALLY.

QUALITY ASSURANCE AND SPECIAL INSPECTION:

- TESTING LABORATORY: RETAINED BY OWNER AND SATISFACTORY TO ENGINEER OF RECORD (THROUGH UNIRAC) AND GOVERNING CODE AUTHORITY TO PERFORM REQUIRED TESTS AND INSPECTIONS OF THIS CONTRACT AND APPLICABLE CODE. THE TYPE AND FREQUENCY OF SPECIAL INSPECTION, STRUCTURAL TESTING AND SUBSEQUENT REPORTING SHALL CONFORM TO THE REQUIREMENTS OF THE 2009 INTERNATIONAL BUILDING CODE (IBC).

CONCRETE:

- ALL ASPECTS OF WORK PERTAINING TO THE CONCRETE CONSTRUCTION SHALL BE IN ACCORDANCE WITH ACI 318-08, "BUILDING CODE REQUIREMENTS FOR STRUCTURAL CONCRETE" AND THE LATEST EDITION OF "SPECIFICATIONS FOR STRUCTURAL CONCRETE FOR BUILDINGS" ACI 301, WITH MODIFICATIONS AS NOTED ON THE PROJECT DRAWINGS AND/OR SPECIFICATIONS.
- HOT WEATHER CONCRETING SHALL CONFORM TO ACI 305, "HOT WEATHER CONCRETING".
- COLD WEATHER CONCRETING SHALL CONFORM TO ACI 306, "COLD WEATHER CONCRETING".
- ALL MIX DESIGNS SHALL BE DESIGNED BY A QUALIFIED TESTING LABORATORY AND SHALL BE WET STAMPED BY A CIVIL ENGINEER LICENSED IN THE JURISDICTION OF THE PROJECT. BASE DESIGN MIX BASED ON FIELD EXPERIENCE OR TRIAL MIXTURES AS STIPULATED IN IBC SECTION 1905.3.
- TYPE II PORTLAND CEMENT SHALL BE USED AT ALL CONCRETE ALTERNATE FOUNDATION LOCATIONS FOR THE RACKING SYSTEM - WHERE CONCRETE IS REQUIRED AS AN ALTERNATE SOLUTION. (TYPE V CEMENT SHALL BE USED WHERE THE CONCRETE IS IN CONTACT WITH SOIL CONTAINING SULFATES IN EXCESS OF 3000 PPM. CONCRETE THAT WILL BE EXPOSED TO SULFATE-CONTAINING SOLUTIONS SHALL COMPLY WITH IBC SECTION 1904.3 AND ACI 318-05 TABLE 4.3.1 SEVERE AND VERY SEVERE SULFATE EXPOSURES AS IDENTIFIED IN THE PROJECT GEOTECHNICAL REPORT. THE WATER CEMENT RATIO SHALL NOT EXCEED 0.44.)
- IN THE PRESENCE OF REACTIVE AGGREGATE, CLASS F FLY ASH OR OTHER ASR MITIGATING ADMIXTURE SHALL BE INCORPORATED IN THE MIX SUCH THAT THE EXPANSION PRODUCED BY THE MORTAR-BAR METHOD (ASTM C1567) USING BLENDED AGGREGATES IS LESS THAN 0.1% AT 14 DAYS IMMERSED IN SOLUTION. WHERE CLASS F FLY ASH IS SELECTED AS A SUPPLEMENTAL ADMIXTURE. THE LOSS OF IGNITION SHALL BE LIMITED TO 2%. THE CONTRACTOR SHALL SUBMIT ALL CERTIFICATES SHOWING THE FLY ASH IS IN ACCORDANCE WITH ASTM 6618.
- DO NOT USE CONCRETE OR GROUT CONTAINING CHLORIDES. WATER SHALL CONTAIN A CHLORIDE CONTENT LESS THAN 1000 PPM AS C1. DO NOT USE CONCRETE CONTAINING ALKALI-CARBONATE AND BIOCARBONATES PRESENT IN AGGREGATE IN EXCESS OF 1000 PPM. TESTS FOR THEIR EFFECT ON SETTING TIME AND 28 DAY STRENGTH SHALL BE EVALUATED.
- HARD ROCK CONCRETE AGGREGATE SHALL CONFORM TO ALL REQUIREMENTS AND TESTS OF THE ASTM C33 CLASS DESIGNATION 35 AND PROJECT SPECIFICATIONS. EXCEPTIONS MAY BE USED ONLY WITH APPROVAL OF THE STRUCTURAL ENGINEER. PROVIDE CONCRETE MIX DESIGN WITH PROVEN SHRINKAGE CHARACTERISTICS OF LESS THAN 0.0005 INCHES/INCH.
- MAXIMUM SIZED AGGREGATE OF 0.75".
- SLUMP RANGE OF 3" ± 1" PER ASTM C143.
- CONCRETE PLACEMENT SHALL BE IN ACCORDANCE WITH ACI STANDARD 304 AND PROJECT SPECIFICATIONS.
- THE UNIRAC PILE SHALL BE CENTERED IN THE HOLE TO MAXIMIZE CONCRETE COVER AND THE HOLE SHALL BE CENTERED IN THE SPECIFIED LOCATION TO ALLOW FOR RACKING INSTALLABILITY.
- THE TOP OF THE CONCRETE SHALL BE SMOOTHED AND SLOPED AT 2% TO FACILITATE POSITIVE DRAINAGE AWAY FROM THE UNIRAC PILE.
- CONCRETE CHLORIDE PERMEABILITY SHALL BE CLASSIFIED AS HAVING "NEGLECTIBLE" TO "VERY LOW" CHLORIDE ION PERMEABILITY PER ASTM C1202.
- CONCRETE SHOULD BE PLACED IN A CONTINUOUS FLOW WITHOUT SEGREGATING THE CONCRETE. DO NOT ALLOW CONCRETE TO FREE FALL MORE THAN 5 FEET UNLESS MEASURES ARE TAKEN TO ENSURE THAT CONCRETE DOES NOT HIT THE SIDES OF THE EXCAVATION DURING FREE FALL.
- MECHANICALLY VIBRATE THE CONCRETE AT EACH PIER.
- PRECAUTIONS SHOULD BE TAKEN DURING THE INSTALLATION OF PIERS TO MINIMIZE THE POSSIBILITY OF CAVING. PIER EXCAVATIONS SHOULD BE FILLED WITH CONCRETE AS SOON AFTER DRILLING AND INSPECTION AS POSSIBLE. SONOTUBES (OR EQUIVALENT) CAN BE UTILIZED, AS REQUIRED, ONLY IN THE UPPER 2 FT. OF THE AUGERED/DRILLED HOLE.
- CONCRETE MIXING OPERATION SHALL CONFORM TO ASTM C-94.
- AGGREGATE FOR HARDROCK CONCRETE SHALL CONFORM TO ALL REQUIREMENTS AND TESTS OF THE ASTM C-33 AND PROJECT SPECIFICATIONS. EXCEPTIONS MAY BE USED ONLY WITH THE PERMISSION OF THE ENGINEER OF RECORD.
- THE MAXIMUM DENSITY OF CONCRETE SHALL BE 150 PCF. THE 28 DAY STRENGTH OF CONCRETE SHALL BE 4000 PSI WITH A MAXIMUM WATER-CEMENT RATIO OF 0.40.

| SHEET INDEX | |
|--------------|--|
| SHEET NUMBER | SHEET TITLE |
| SD - 100 | GENERAL STRUCTURAL RACKING NOTES |
| SD - 200 | RACKING DIMENSIONS & PARTS LIST - 20 DEGREE TILT |
| SD - 300 | RACKING DIMENSIONS & PARTS LIST - 30 DEGREE TILT |
| SD - 400 | FOUNDATION EMBEDMENT AND FOUNDATION DETAILS |
| SD - 500 | RACKING DETAILS |

| REVISION BLOCK | | |
|----------------|-----------|------------------------|
| MARK | DATE | DESCRIPTION |
| 0 | 9/30/2016 | ORIGINAL RELEASE |
| 1 | 10/19/16 | NOTE & BRACE REVISIONS |
| 2 | 1/06/2017 | ADDED SD-200 |
| 3 | 2/02/2017 | REVED NOTES |
| 4 | 2/19/2017 | REVED NOTES & SD-300 |

OWNER/CLIENT:

ENGINEERING CONSULTANT:
Design Optimization Technologies
424 Jefferson Street
St. Charles, MO 63301
Phone: (636) 724-9872
www.DOtecEngineering.com

PROFESSIONAL SEAL

SEE STATE
SPECIFIC STAMPED
& SIGNED GFT
CERTIFICATION
LETTER

UNIRAC'S DGFT
DISTRIBUTION GROUND FIXED TILT
STRUCTURAL RACKING DRAWINGS

UNIRAC
1411 Broadway Boulevard, NE
Albuquerque, New Mexico 87102
Phone: (505) 242-6412
Fax: (505) 242-6412
www.unirac.com

ALL INFORMATION PROVIDED HEREIN IS CONFIDENTIAL AND PROPRIETARY AND IS SOLE PROPERTY OF UNIRAC, INC. REPRODUCTION AND DISTRIBUTION WITHOUT THE WRITTEN PERMISSION OF UNIRAC, INC. IS STRICTLY PROHIBITED.

| | |
|------------------------|-------------|
| PROJECT NUMBER: | DGFT |
| ENGINEERED BY: | Jon S |
| DRAFTED BY: | Jeff H |
| REVIEWED BY: | Jeff H |
| ORIGINAL RELEASE DATE: | 9/30/2016 |
| DRAWING SHEET SIZE: | 17" x 24x36 |

SHEET TITLE
GENERAL
STRUCTURAL RACKING
NOTES

SHEET NUMBER
SD-100
SHEET
1 of 5

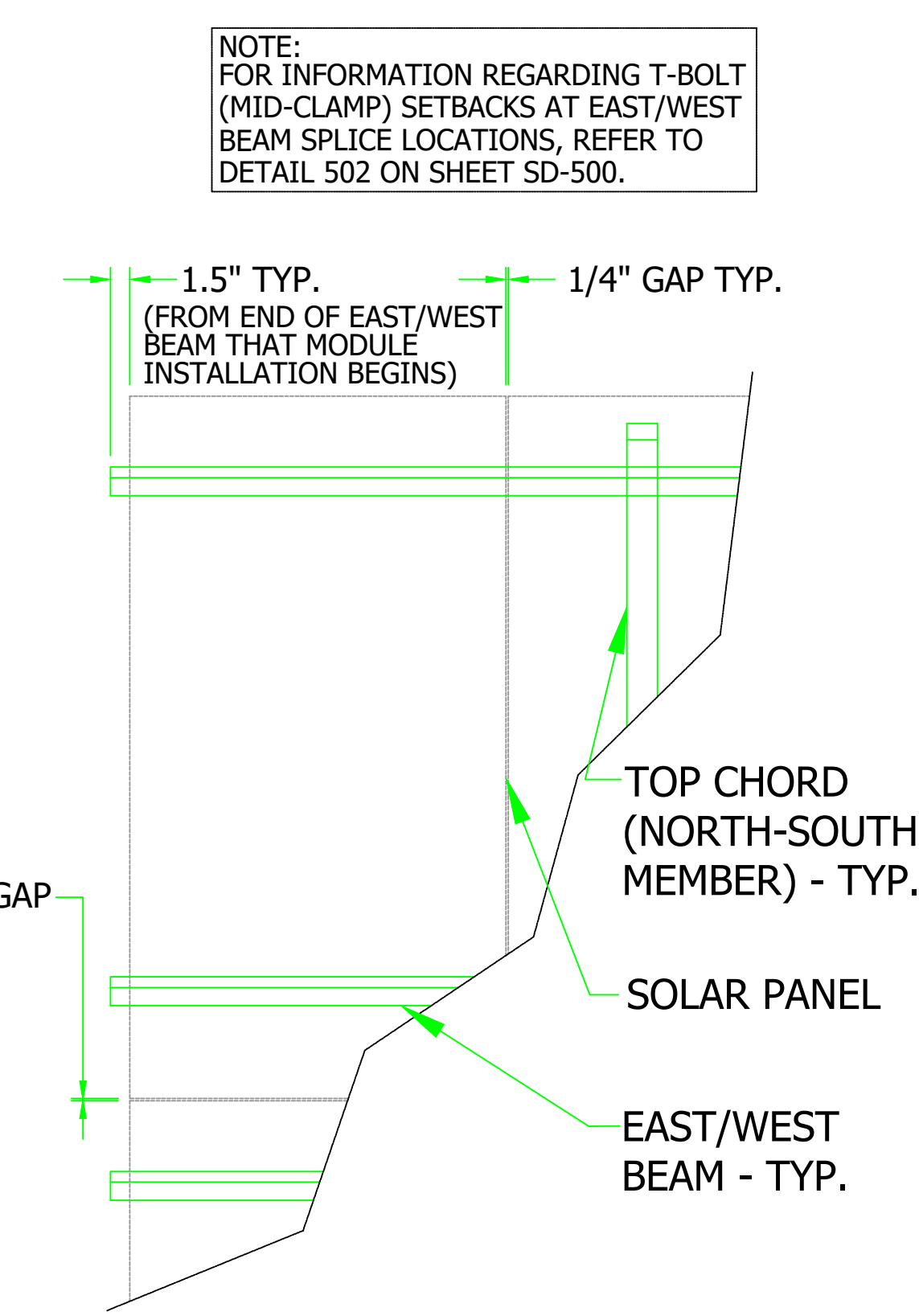
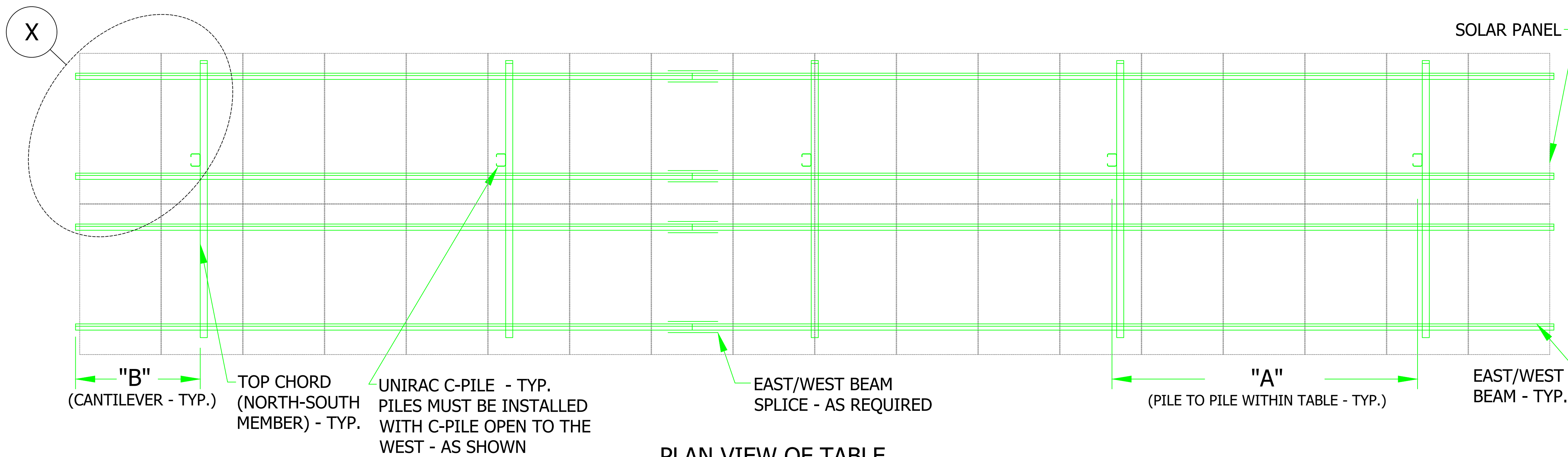

NOTE:
FOR INFORMATION REGARDING T-BOLT (MID-CLAMP) SETBACKS AT EAST/WEST BEAM SPLICE LOCATIONS, REFER TO DETAIL 502 ON SHEET SD-500.

| GFT PARTS LIST | | | |
|----------------|----------------------|------------------|--------|
| REF NUMBER | PART DESCRIPTION | QUAGE/ THICKNESS | FINISH |
| A | ALUMINUM E-W BEAM | - | MILL |
| B | TOP CHORD CHANNEL | 14 | G180 |
| C | FRONT DIAGONAL BRACE | 14 | G180 |
| D | REAR DIAGONAL BRACE | 14 | G180 |
| E | DIAGONAL BRACE PLATE | - | G180 |
| F | C-PILE | 11 | G235 |

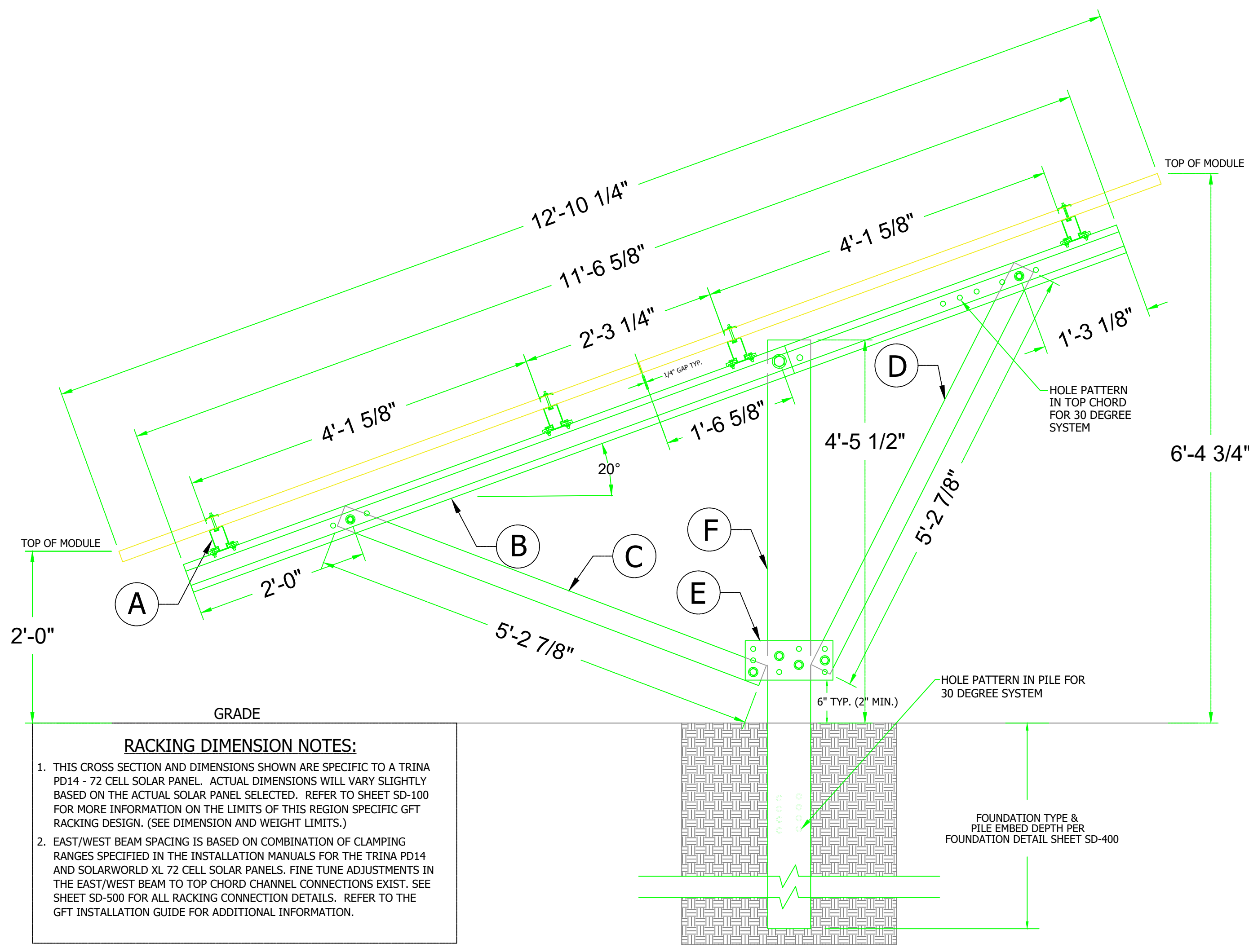

NOTE: IF DESIRED FOR AESTHETICS, CONTRACTOR/OWNER IS ALLOWED TO CUT OFF THE EXCESS PORTION OF THE TOP CHORD CHANNEL

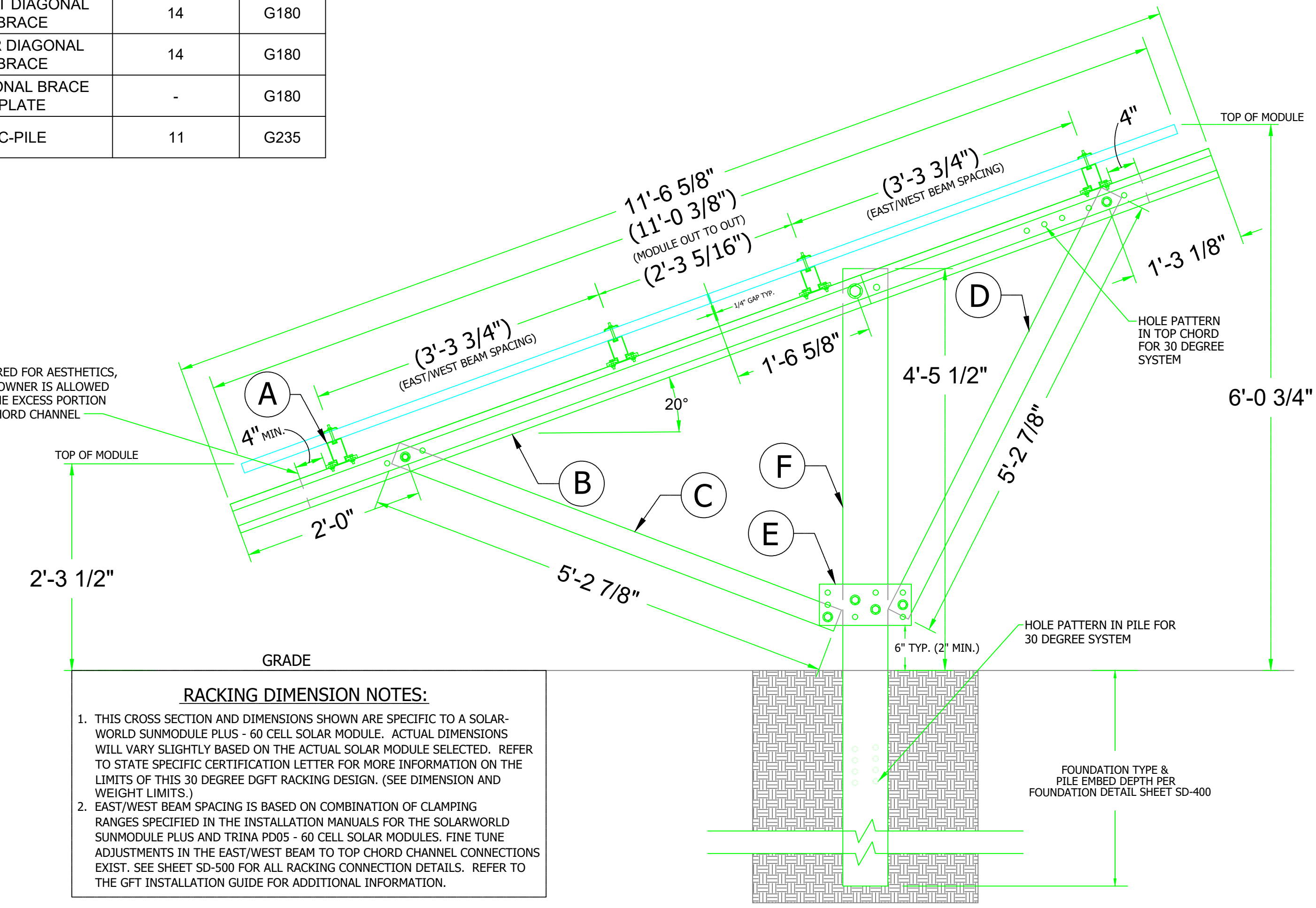

| REVISION BLOCK | | |
|----------------|-----------|----------------------|
| MARK | DATE | DESCRIPTION |
| 3 | 1/5/2017 | 20" ORIGINAL RELEASE |
| 4 | 2/13/2017 | ADDED HOLES FOR 30" |
| - | - | - |
| - | - | - |

OWNER/CLIENT:

ENGINEERING CONSULTANT:
Design Optimization Technologies
424 Jefferson Street
St. Charles, Mo 63301
Phone: (636) 724-9872
www.DOTecEngineering.com

PROFESSIONAL SEAL

SEE STATE SPECIFIC STAMPED & SIGNED GFT CERTIFICATION LETTER

UNIRAC'S DGFT
DISTRIBUTION GROUND FIXED TILT
STRUCTURAL RACKING DRAWINGS

UNIRAC
1411 Broadway Boulevard NE
Albuquerque, New Mexico 87102
Phone: (505) 242-6411
Fax: (505) 242-6412
www.unirac.com

ALL INFORMATION PROVIDED HEREIN IS CONFIDENTIAL AND PROPRIETARY AND IS SOLE PROPERTY OF UNIRAC, INC. REPRODUCTION AND TRANSMISSION IN ANY FORM OR BY ANY MEANS WITHOUT THE WRITTEN CONSENT OF UNIRAC, INC. IS STRICTLY PROHIBITED.

PROJECT NUMBER: DGFT
ENGINEERED BY: Jeff H
DRAFTED BY: Jeff H
REVIEWED BY: Jeff H
ORIGINAL RELEASE DATE: 9/30/2016
DRAWING SHEET SIZE: D - 24x36

SHEET TITLE
GFT TABLE CROSS-SECTION AND PARTS LIST
(20 DEGREE TILT)

SHEET NUMBER
SD-200
SHEET 2 of 5

X

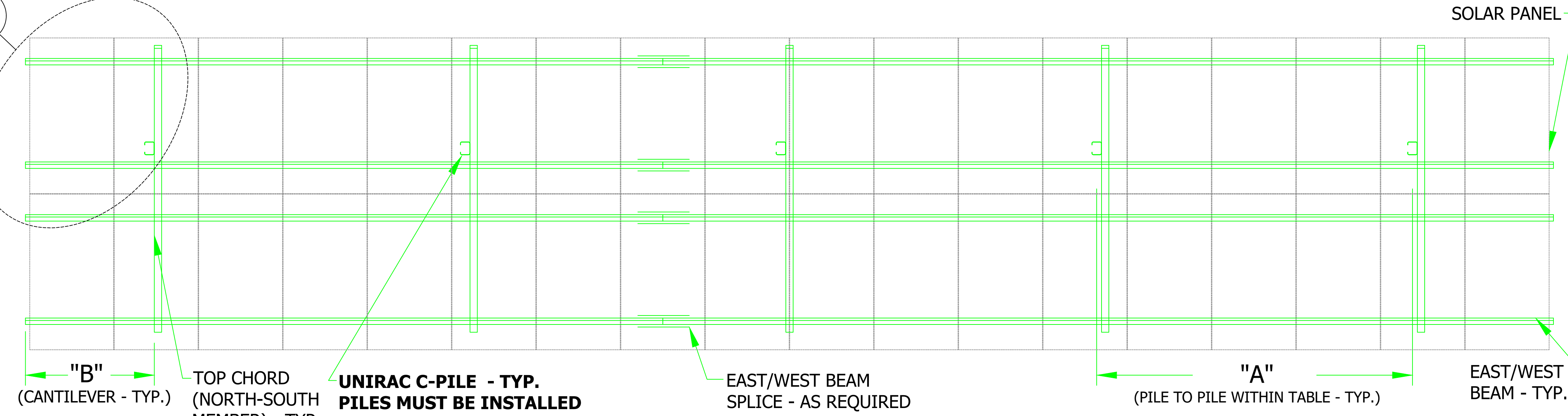

UNIRAC C-PILE - TYP. PILES MUST BE INSTALLED WITH C-PILE OPEN TO THE WEST - AS SHOWN

PLAN VIEW OF TABLE

SEE LETTER FOR PILE QUANTITY REQUIREMENT PER TABLE SIZE

NOTE:
FOR INFORMATION REGARDING T-BOLT (MID-CLAMP) SETBACKS AT EAST/WEST BEAM SPLICE LOCATIONS, REFER TO DETAIL 502 ON SHEET SD-500.

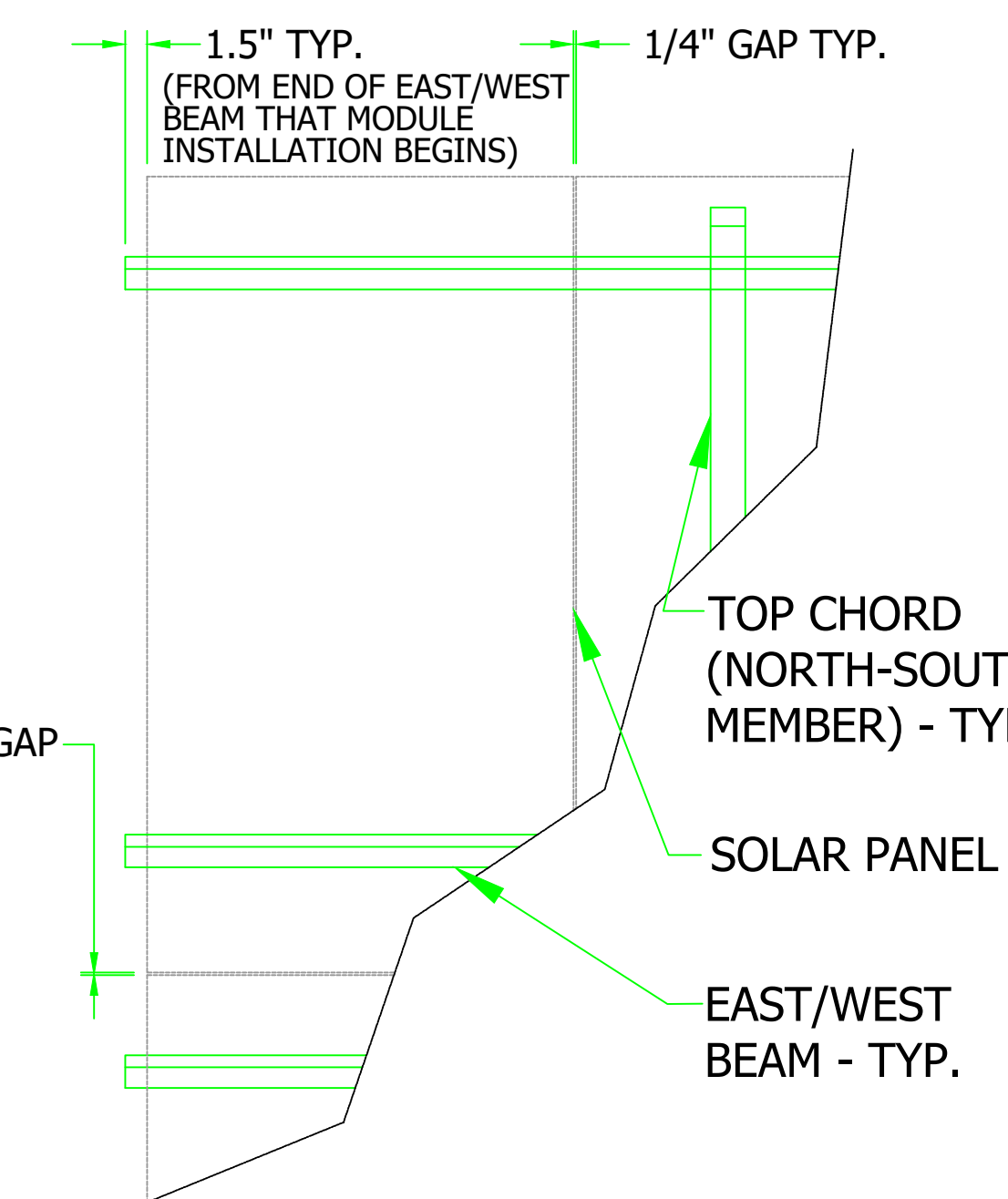

DETAILED VIEW

| GFT PARTS LIST | | | |
|----------------|----------------------|------------------|--------|
| REF NUMBER | PART DESCRIPTION | GAUGE/ THICKNESS | FINISH |
| A | ALUMINUM E-W BEAM | - | MILL |
| B | TOP CHORD CHANNEL | 14 | G180 |
| C | FRONT DIAGONAL BRACE | 14 | G180 |
| D | REAR DIAGONAL BRACE | 14 | G180 |
| E | DIAGONAL BRACE PLATE | - | G180 |
| F | C-PILE | 11 | G235 |

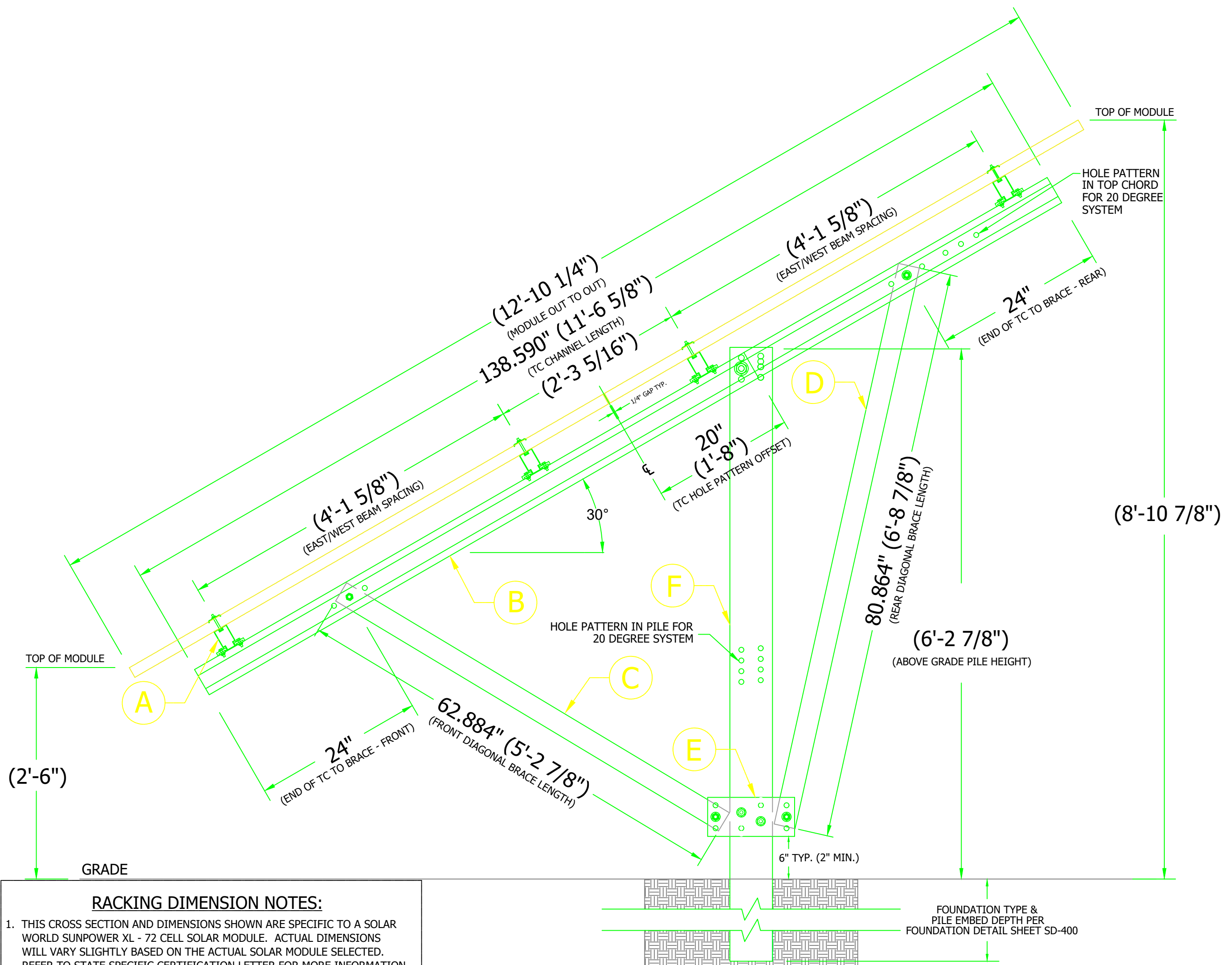

SECTION VIEW OF TABLE (72 CELL SOLAR PANELS) (30 DEGREE TILT)

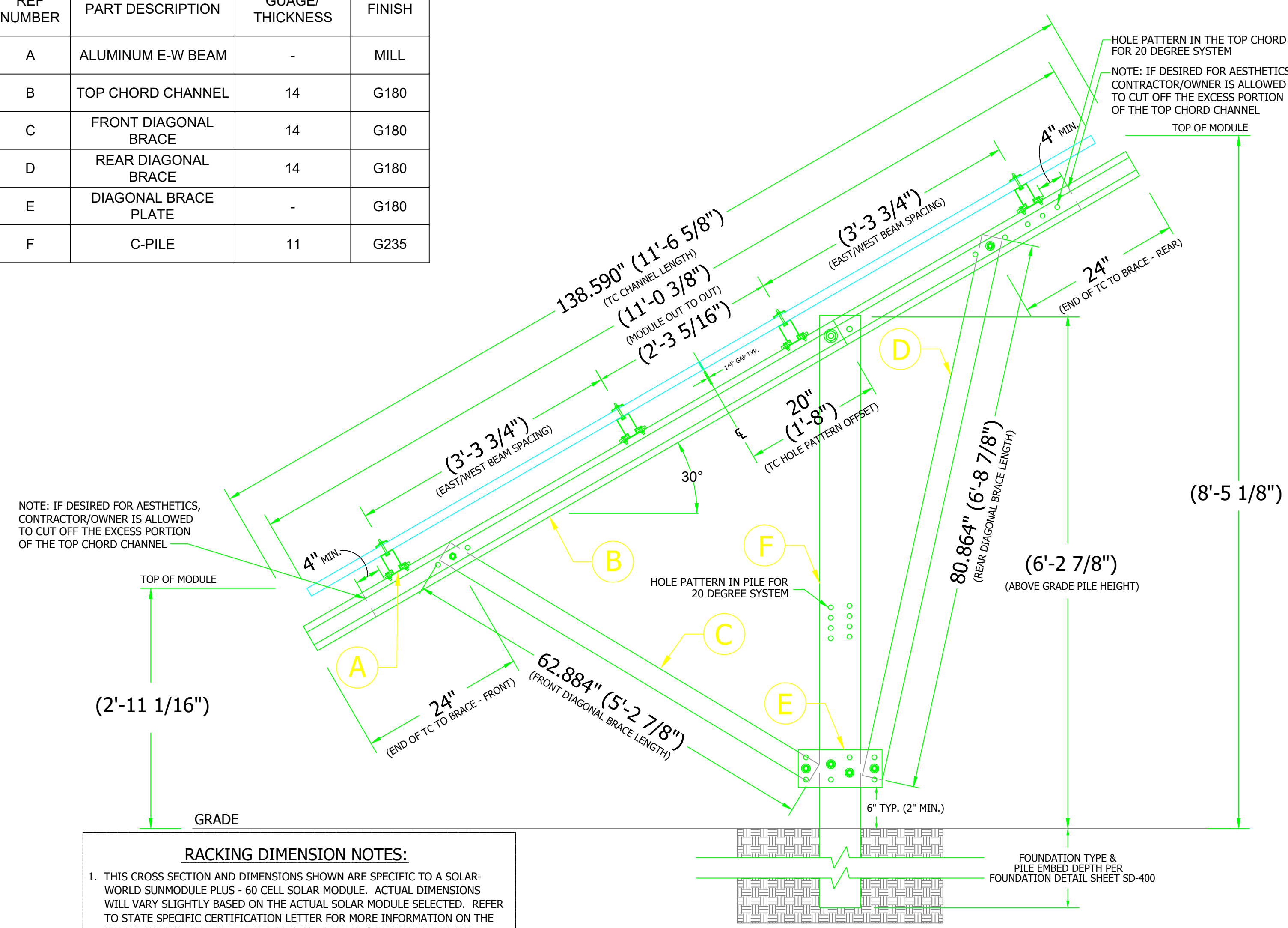

RACKING DIMENSION NOTES:

- THIS CROSS SECTION AND DIMENSIONS SHOWN ARE SPECIFIC TO A SOLAR-WORLD SUNMODULE PLUS - 60 CELL SOLAR MODULE. ACTUAL DIMENSIONS WILL VARY SLIGHTLY BASED ON THE ACTUAL SOLAR MODULE SELECTED. REFER TO STATE SPECIFIC CERTIFICATION LETTER FOR MORE INFORMATION ON THE LIMITS OF THIS 30 DEGREE DGFT RACKING DESIGN. (SEE DIMENSION AND WEIGHT LIMITS.)
- EAST/WEST BEAM SPACING IS BASED ON COMBINATION OF CLAMPING RANGES SPECIFIED IN THE INSTALLATION MANUALS FOR THE SOLARWORLD SUNMODULE PLUS AND TRINA PD05 - 60 CELL SOLAR MODULES. FINE TUNE ADJUSTMENTS IN THE EAST/WEST BEAM TO TOP CHORD CHANNEL CONNECTIONS EXIST. SEE SHEET SD-500 FOR ALL RACKING CONNECTION DETAILS. REFER TO THE GFT INSTALLATION GUIDE FOR ADDITIONAL INFORMATION.

SECTION VIEW OF TABLE (60 CELL SOLAR PANELS) (30 DEGREE TILT)

RACKING DIMENSION NOTES:

- THIS CROSS SECTION AND DIMENSIONS SHOWN ARE SPECIFIC TO A SOLAR WORLD SUNPOWER XL - 72 CELL SOLAR MODULE. ACTUAL DIMENSIONS WILL VARY SLIGHTLY BASED ON THE ACTUAL SOLAR MODULE SELECTED. REFER TO STATE SPECIFIC CERTIFICATION LETTER FOR MORE INFORMATION ON THE LIMITS OF THIS 30 DEGREE DGFT RACKING DESIGN. (SEE DIMENSION AND WEIGHT LIMITS.)
- EAST/WEST BEAM SPACING IS BASED ON COMBINATION OF CLAMPING RANGES SPECIFIED IN THE INSTALLATION MANUALS FOR THE SOLARWORLD XL 72 CELL SOLAR MODULES. FINE TUNE ADJUSTMENTS IN THE EAST/WEST BEAM TO TOP CHORD CHANNEL CONNECTIONS EXIST. SEE SHEET SD-500 FOR ALL RACKING CONNECTION DETAILS. REFER TO THE DGFT INSTALLATION GUIDE FOR ADDITIONAL INFORMATION.

| REVISION BLOCK | | |
|----------------|-----------|------------------------|
| MARK | DATE | DESCRIPTION |
| 0 | 9/30/2016 | ORIGINAL RELEASE |
| 1 | 10/19/16 | NOTE & BRACE REVISIONS |
| 2 | 1/08/2017 | ADDED SD-200 |
| 3 | 2/02/2017 | REVISED NOTES |
| 4 | 2/13/2017 | REVISED NOTES & SD-300 |

OWNER/CLIENT:

ENGINEERING CONSULTANT:
Design Optimization Technologies
424 Jefferson Street
St. Charles, Mo 63301
Phone: (636) 724-9872
www.DOTecEngineering.com

PROFESSIONAL SEAL

SEE STATE SPECIFIC STAMPED & SIGNED GFT CERTIFICATION LETTER

UNIRAC'S DGFT DISTRIBUTION GROUND FIXED TILT STRUCTURAL RACKING DRAWINGS

| | |
|------------------------|------------|
| PROJECT NUMBER: | DGFT |
| ENGINEERED BY: | Jim S |
| DRAFTED BY: | Jeff H |
| REVIEWED BY: | Jeff H |
| ORIGINAL RELEASE DATE: | 9/30/2016 |
| DRAWING SHEET SIZE: | D' - 24x36 |

SHEET TITLE
GFT TABLE CROSS-SECTION AND PARTS LIST (30 DEGREE TILT)

SHEET NUMBER
SD-300

| REVISION BLOCK | | |
|----------------|-----------|------------------------|
| MARK | DATE | DESCRIPTION |
| 0 | 9/30/2016 | ORIGINAL RELEASE |
| 1 | 10/19/16 | NOTE & BRACE REVISIONS |
| 2 | 1/06/2017 | ADDED SD-200 |
| 3 | 2/02/2017 | REVISED NOTES |
| 4 | 2/13/2017 | REVISED NOTES & SD-300 |

OWNER/CLIENT:

ENGINEERING CONSULTANT:
 Design Optimization Technologies
 424 Jefferson Street
 St. Charles, Mo 63301
 Phone: (636) 724-9872
 www.DOTecEngineering.com

PROFESSIONAL SEAL

SEE STATE
 SPECIFIC STAMPED
 & SIGNED GFT
 CERTIFICATION
 LETTER

UNIRAC'S DGFT
 DISTRIBUTION GROUND FIXED TILT
 STRUCTURAL RACKING DRAWINGS

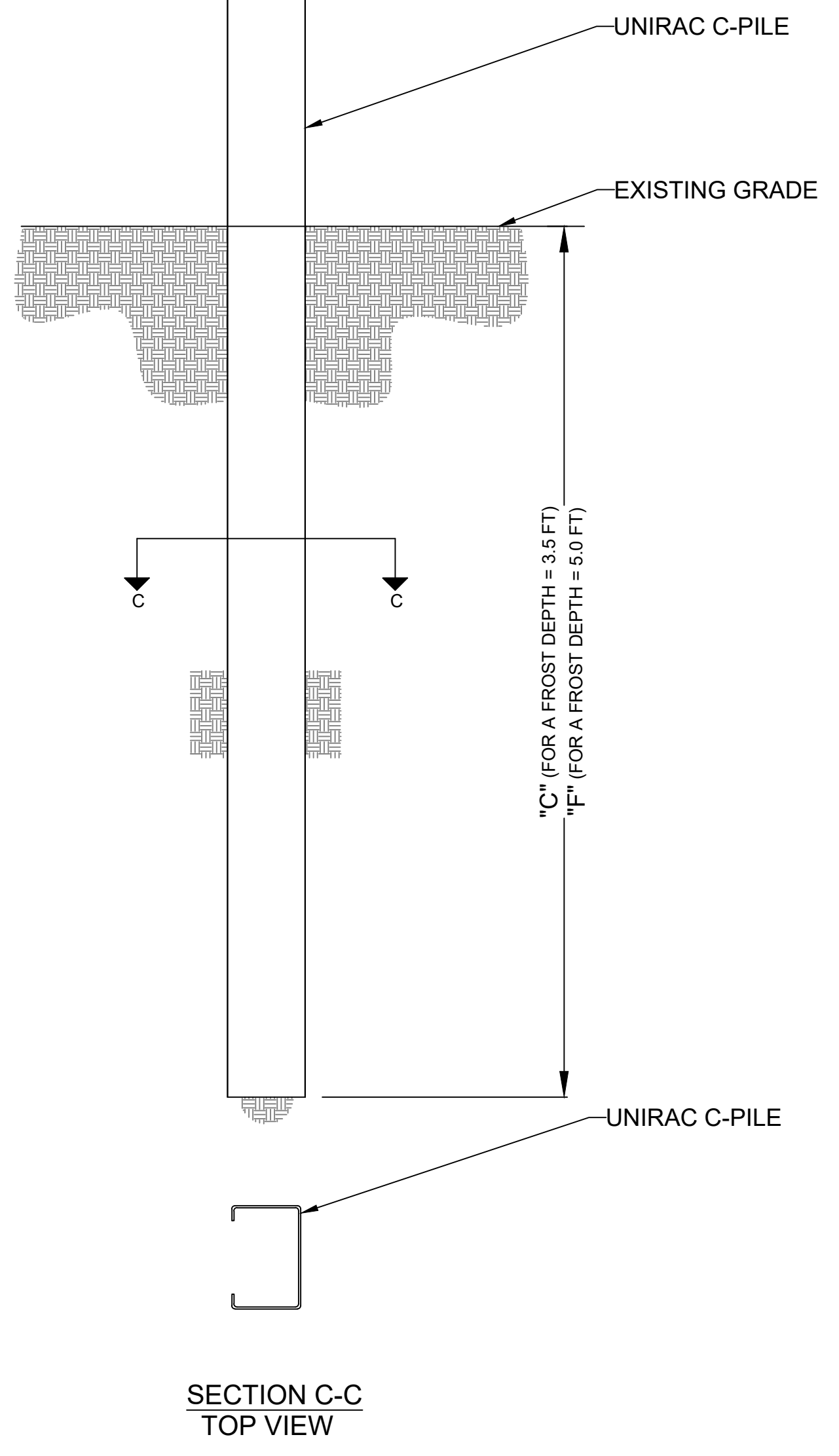
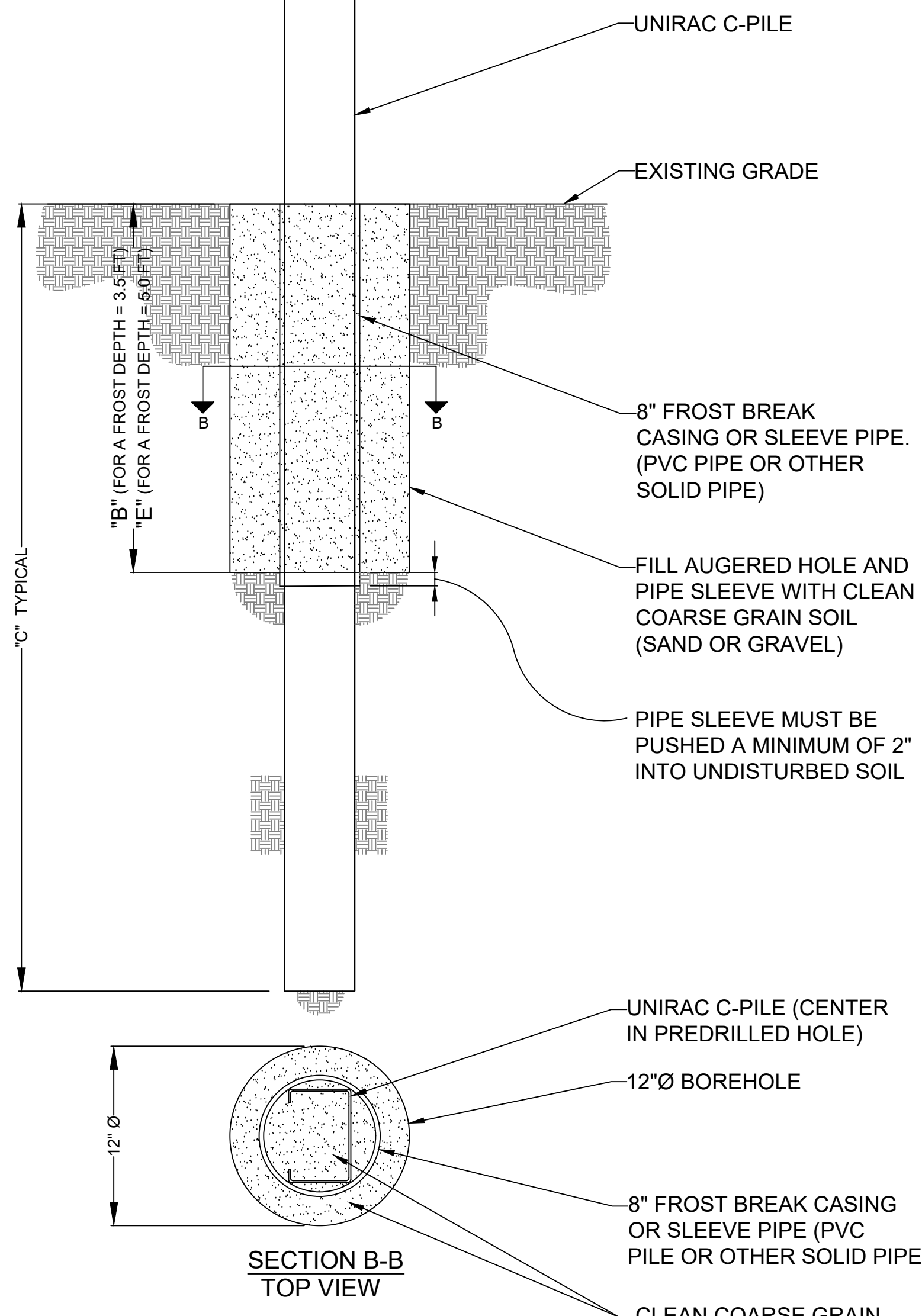
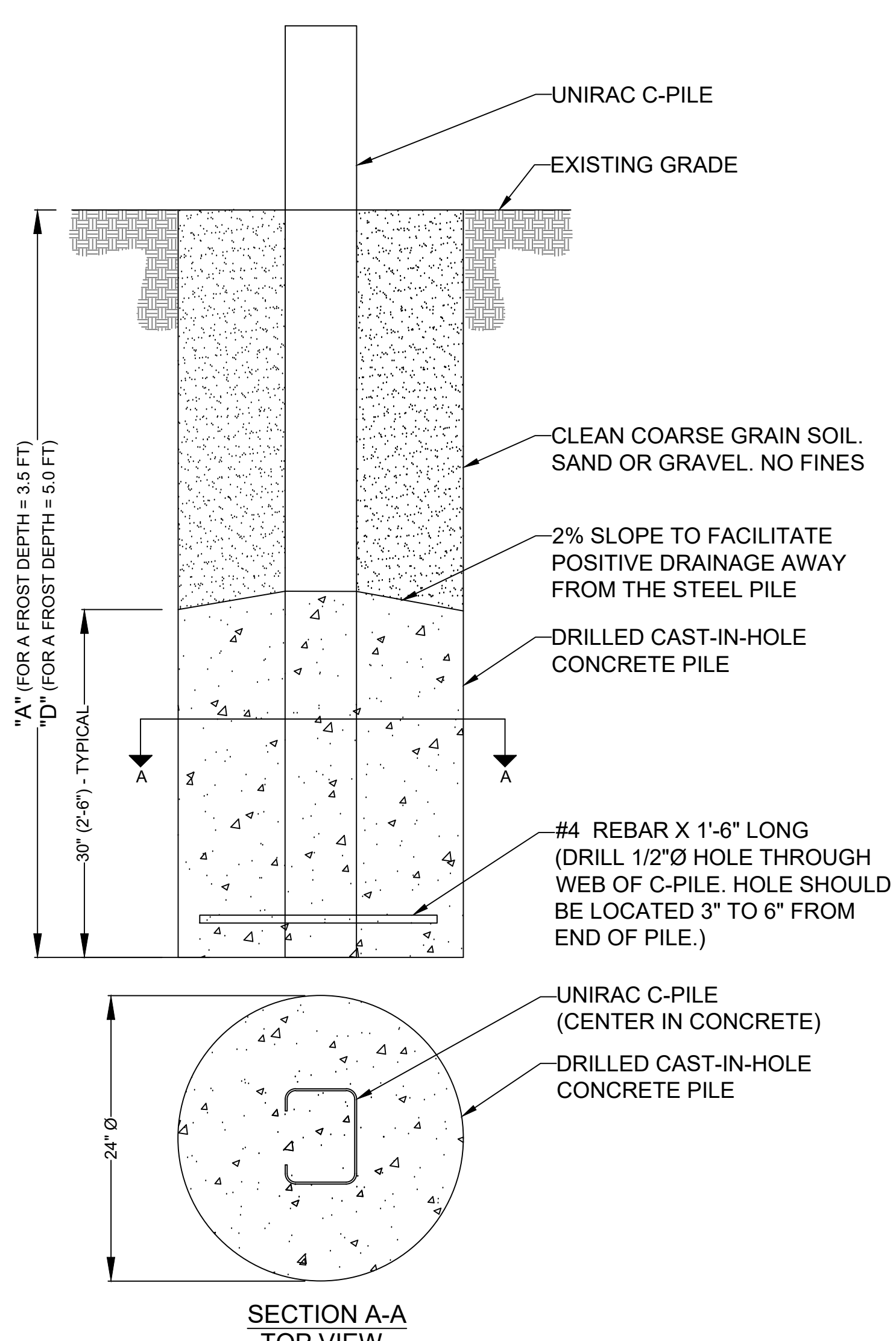
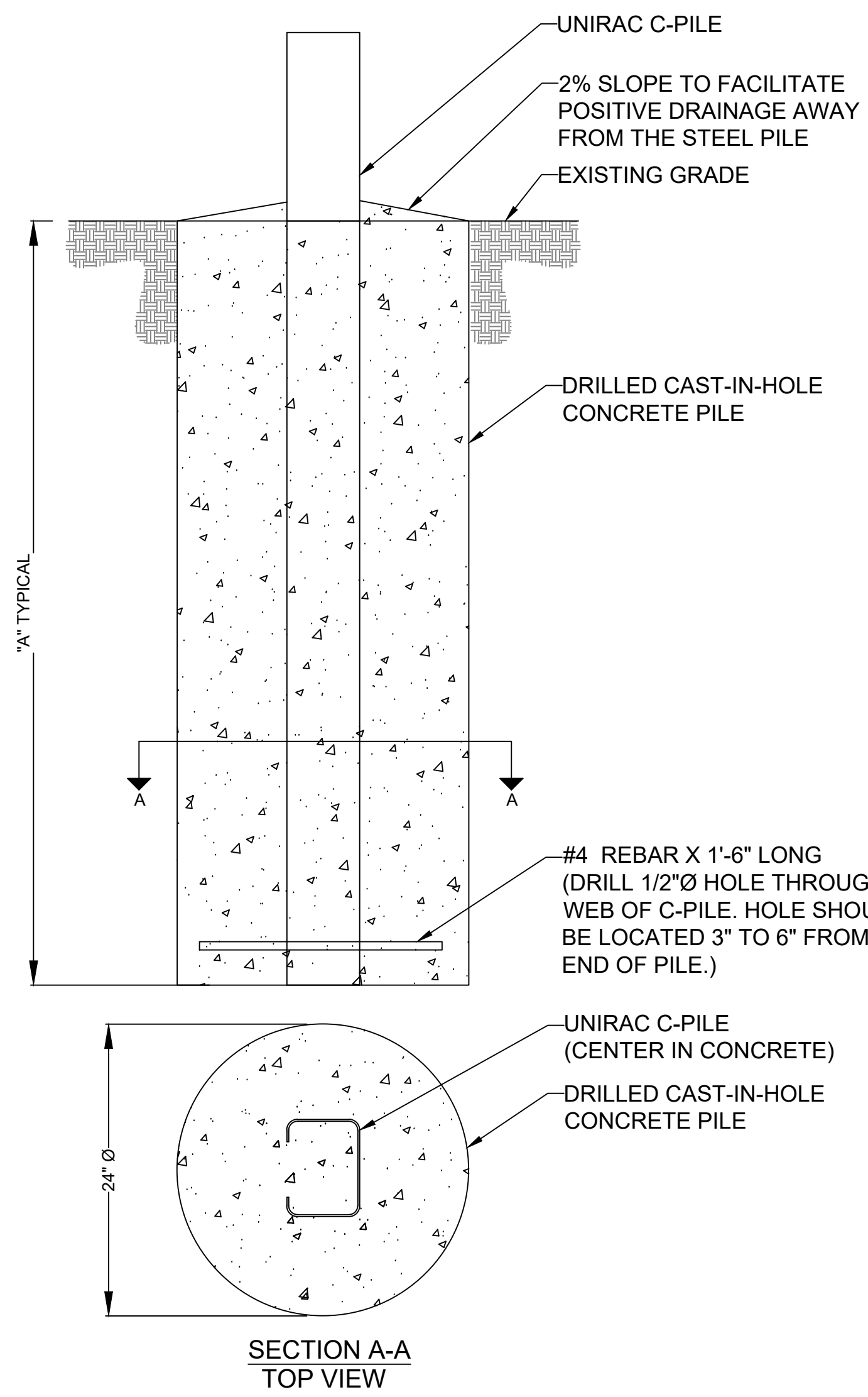

400 DRILLED CAST-IN-HOLE CONCRETE PILE FOUNDATION (ALTERNATE OPTION) NOT TO SCALE

401 DRILLED "PARTIAL" CAST-IN-HOLE CONCRETE PILE FOUNDATION (ALTERNATE OPTION) NOT TO SCALE

402 PARTIAL DRIVEN PILE WITH CLEAN COARSE BACKFILL (ALTERNATE OPTION) NOT TO SCALE

403 FULLY DRIVEN PILE (ALTERNATE OPTION) NOT TO SCALE

- FOUNDATION 400: DRILLED CAST-IN-HOLE CONCRETE PILE FOUNDATION
1. THE FOUNDATION MUST BE EXCAVATED WITH LITTLE TO NO LOOSE MATERIAL IN THE BOTTOM.
 2. IF THE FOUNDATION IS BELOW THE GROUND WATER LEVEL, THERE MUST BE A TEMPORARY CASING IN PLACE TO STABILIZE THE EXCAVATION.
 3. THE PILE SHALL HAVE A #4 REBAR PLACED THROUGH THE BOTTOM OF THE PILE.
 4. THE PILE MUST BE CENTERED IN THE HOLE WITH EQUAL AMOUNTS OF CONCRETE AROUND THE CASING.
 5. CONCRETE SHALL CONFORM TO THE CONCRETE SPECIFICATIONS LISTED ON DR-100.
 6. CONCRETE DEPTH SHALL CONFIRM TO THE DEPTHS LISTED IN THE TABLE ON THIS SHEET.
 7. THE TOP OF THE CONCRETE MUST BE ABOVE GARDE.
 8. THE CORE OF THE CONCRETE CAST-IN-DRILLED HOLE PILE WILL CONSIST OF THE UNIRAC C- PILES AS DEPICTED IN THE FIGURE.

- FOUNDATION 401: DRILLED "PARTIAL" CAST-IN-HOLE CONCRETE PILE FOUNDATION
1. THE FOUNDATION MUST BE EXCAVATED WITH LITTLE TO NO LOOSE MATERIAL IN THE BOTTOM.
 2. IF THE FOUNDATION IS BELOW THE GROUND WATER LEVEL, THERE MUST BE A TEMPORARY CASING IN PLACE TO STABILIZE THE EXCAVATION.
 3. THE PILE SHALL HAVE A #4 REBAR PLACED THROUGH THE BOTTOM OF THE PILE.
 4. THE PILE MUST BE CENTERED IN THE HOLE WITH EQUAL AMOUNTS OF CONCRETE AROUND THE CASING.
 5. CONCRETE SHALL CONFORM TO THE CONCRETE SPECIFICATIONS LISTED ON DR-100.
 6. CONCRETE DEPTH SHALL CONFIRM TO THE DEPTHS LISTED IN THE TABLE ON THIS SHEET.
 7. THE TOP OF THE CONCRETE MUST BE BELOW THE DEPTH OF THE FROST ZONE.
 8. THE CORE OF THE CONCRETE CAST-IN-DRILLED HOLE PILE WILL CONSIST OF THE UNIRAC C- PILES AS DEPICTED IN THE FIGURE.
 9. THE BACKFILL MATERIAL MUST CONSIST OF MEDIUM TO COARSE SAND OR GRAVEL. NO CLAY OR ORGANICS MAY BE USED IN THE BACKFILL.

- FOUNDATION 402: PARTIAL DRIVEN PILE WITH CLEAN COARSE BACKFILL
1. EACH PILE LOCATION MUST BE EXCAVATED TO A MINIMUM OF THE DIMENSION SHOWN.
 2. THE PILE MUST BE CENTERED IN THE HOLE WITH THE FROST BREAK CASING PLACED AROUND THE PILE PRIOR TO BACKFILLING THE EXCAVATION.
 3. THE FROST BREAK CASING MUST NOT HAVE ANY CRACKS OR HOLES THAT MAY ALLOW WATER TO SEEP IN. THE CASING MUST BE SET A MINIMUM OF 2 INCHES INTO THE NATIVE SOIL IN THE BOTTOM OF THE EXCAVATION. THE CASING TOP MUST EXTEND TO THE GROUND SURFACE.
 4. THE FILL MATERIAL MUST CONSIST OF MEDIUM TO COARSE SAND OR GRAVEL WITH LITTLE SILT CONTENT. NO CLAY OR ORGANICS MAY BE USED IN THE BACKFILL MATERIAL.
 5. THE PILE MUST BE INSTALLED TO THE FULL DEPTH INDICATED. PILES NOT DRIVEN TO THE FULL DEPTH ARE CONSIDERED FAILED AND THE CONCRETE OPTION MUST BE UTILIZED.
 6. THE CASING MUST BE FILLED WITH THE SAME FILL MATERIAL AFTER THE PILE IS INSTALLED TO THE CORRECT DEPTH.
 7. THE FILL SHALL BE FORMED IN A WAY TO DIRECT WATER AWAY FROM THE FOUNDATION.
 8. IF THE CASING IS AFFECTED BY FROST HEAVE, THE CASING SHALL BE ATTEMPTED TO BE RE-EMBEDDED TO THE PROPER DEPTH IN ORDER TO PROTECT THE C-PILE FROM FUTURE FROST HEAVE.

- FOUNDATION 403: FULLY DRIVEN PILE:
1. DRIVEN PILE FOUNDATIONS MAY ONLY BE USE IN SOILS THAT ARE NOT FROST SUSCEPTIBLE OR WHERE GROUND WATER IS NOT WITHIN 12 FEET OF THE SURFACE UNLESS APPROVED BY A GEOTECHNICAL ENGINEER. FROST SUSCEPTIBLE SOILS CONSIST OF ANY SOIL THAT IS NOT MEDIUM TO COARSE GRAIN SAND OR GRAVEL. DRIVEN PILE FOUNDATIONS ABSOLUTELY MAY NOT BE USED IN SOILS THAT CONTAIN SILT OR CLAY OR GROUNDWATER WITHIN 12 FEET OF THE SURFACE UNLESS APPROVED BY A GEOTECHNICAL ENGINEER.
 2. PILES MUST BE INSTALLED TO THE FULL DEPTH. PILES NOT DRIVEN TO FULL DEPTH ARE CONSIDERED FAILED PILES AND A DIFFERENT FOUNDATION MUST BE UTILIZED.

NOTE:
 FOR PILE QUANTITY BASED ON TABLE SIZE, SEE TABLES ON THE STATE SPECIFIC CERTIFICATION LETTER. ALSO FOR PILE EMBEDMENT DEPTH AND TOTAL PILE LENGTH, SEE TABLES ON STATE SPECIFIC CERTIFICATION LETTER.

| 20 DEGREE UNIRAC STEEL C-PILE FOUNDATION DEPTHS | | | | | | | |
|---|---------------|------------------------------|---------------|---------------|----------------------|---------------|---------------|
| FOUNDATION TYPE | DETAIL NUMBER | FROST DEPTH = 3.5 FT OR LESS | | | FROST DEPTH = 5.0 FT | | |
| | | DIMENSION "A" | DIMENSION "B" | DIMENSION "C" | DIMENSION "D" | DIMENSION "E" | DIMENSION "F" |
| FULL CAST IN-PLACE CONCRETE | 400 | 8'-0" | -- | -- | 8'-0" | -- | -- |
| CAST IN-PLACE CONCRETE | 401 | 8'-0" | -- | -- | 8'-0" | -- | -- |
| PARTIAL DRIVEN PILE WITH FROST BREAK | 402 | -- | 3'-6" | 10'-6" | -- | 5'-0" | -- |
| FULLY DRIVEN PILE* | 403 | -- | -- | 10'-6" | -- | -- | 10'-6" |

*SHALLOWER EMBEDMENT MAY BE USED IF APPROVED BY A GEOTECHNICAL ENGINEER.

| 30 DEGREE UNIRAC STEEL C-PILE FOUNDATION DEPTHS | | | | | | | |
|---|---------------|------------------------------|---------------|---------------|----------------------|---------------|---------------|
| FOUNDATION TYPE | DETAIL NUMBER | FROST DEPTH = 3.5 FT OR LESS | | | FROST DEPTH = 5.0 FT | | |
| | | DIMENSION "A" | DIMENSION "B" | DIMENSION "C" | DIMENSION "D" | DIMENSION "E" | DIMENSION "F" |
| FULL CAST IN-PLACE CONCRETE | 400 | 6'-0" | -- | -- | 6'-0" | -- | -- |
| CAST IN-PLACE CONCRETE | 401 | 6'-0" | -- | -- | 7'-6" | -- | -- |
| PARTIAL DRIVEN PILE WITH FROST BREAK | 402 | -- | 3'-6" | 8'-6" | -- | 5'-0" | -- |
| FULLY DRIVEN PILE | 403 | -- | -- | 8'-6" | -- | -- | 8'-6" |

*SHALLOWER PILE EMBEDMENT MAY BE USED IF APPROVED BY A GEOTECHNICAL ENGINEER.

UNIRAC
 1411 Broadway Boulevard, NE
 Albuquerque, New Mexico 87102
 Phone: (505) 242-6411
 Fax: (505) 242-6412
 www.unirac.com

ALL INFORMATION PROVIDED HEREIN IS CONFIDENTIAL AND PROPRIETARY AND IS SOLE PROPERTY OF UNIRAC, INC. REPRODUCTION OR TRANSMISSION IN ANY FORM OR BY ANY MEANS WITHOUT THE WRITTEN PERMISSION OF UNIRAC, INC. IS STRICTLY PROHIBITED.

| | |
|------------------------|------------|
| PROJECT NUMBER: | DGFT |
| ENGINEERED BY: | Jan S |
| DRAFTED BY: | Jeff H |
| REVIEWED BY: | Jeff H |
| ORIGINAL RELEASE DATE: | 9/30/2016 |
| DRAWING SHEET SIZE: | D' - 24x36 |

SHEET TITLE
 FOUNDATION EMBEDMENT AND FOUNDATION DETAILS

RACKING DETAIL NOTES:

1. SEE INSTALLATION GUIDE FOR PILE TOLERANCES
2. SEE INSTALLATION GUIDE FOR CONNECTION ADJUSTMENT INSTRUCTIONS
3. SEE INSTALLATION GUIDE FOR INSTRUCTIONS TO INSTALL EAST/WEST BEAM SPLICE
4. DETAILS SEEN ON THIS SHEET ARE NOT DRAWN TO SCALE

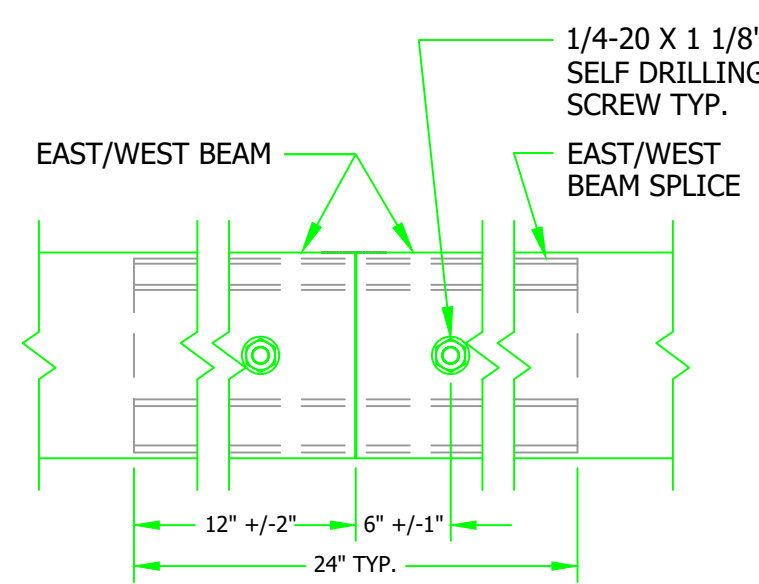
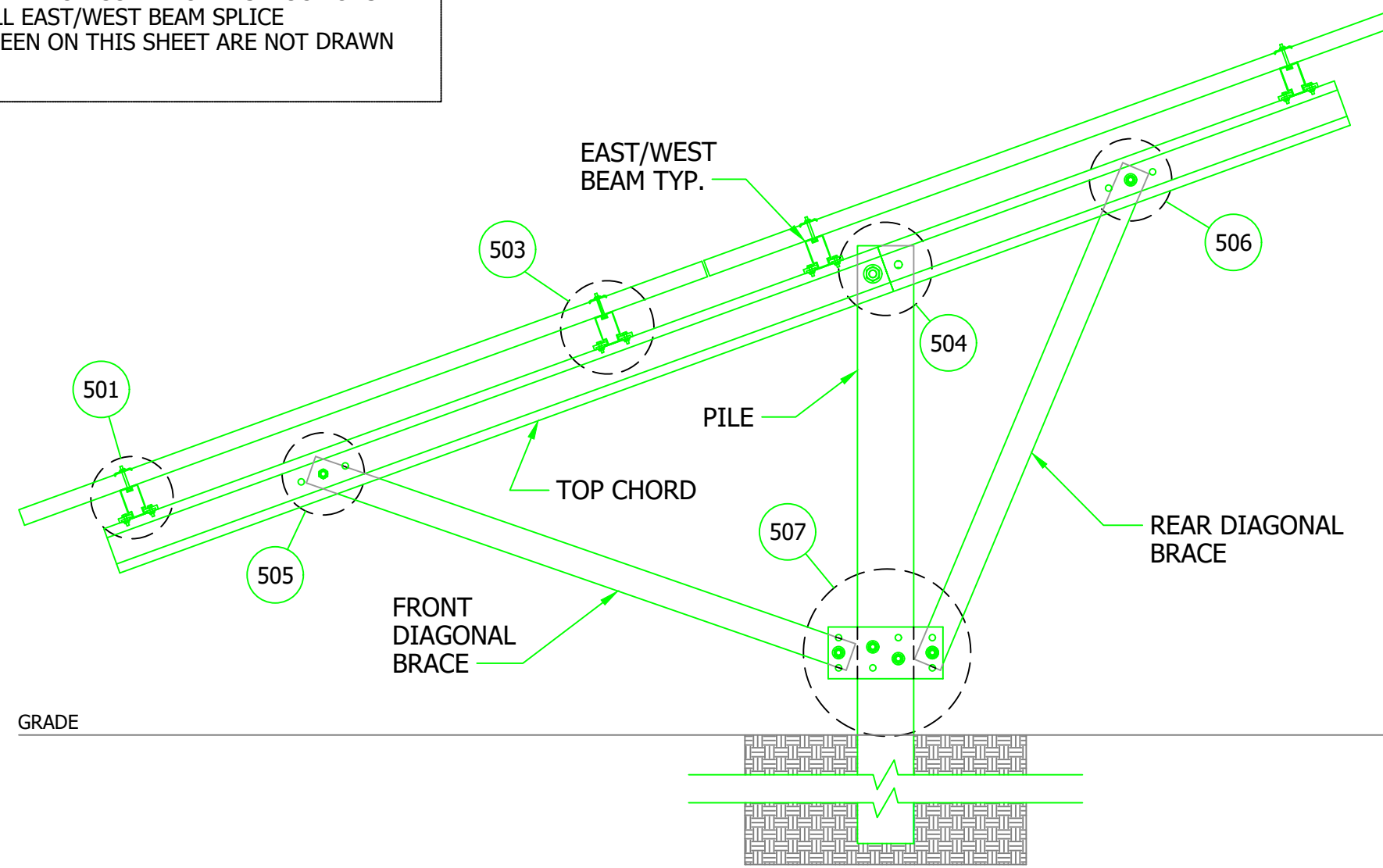

EAST/WEST BEAM WITH SPLICE
(TYPICAL ELEVATION)

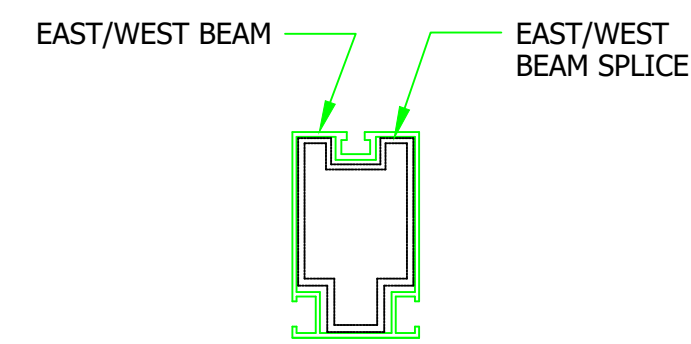

EAST/WEST BEAM WITH SPLICE
(TYPICAL SECTION)

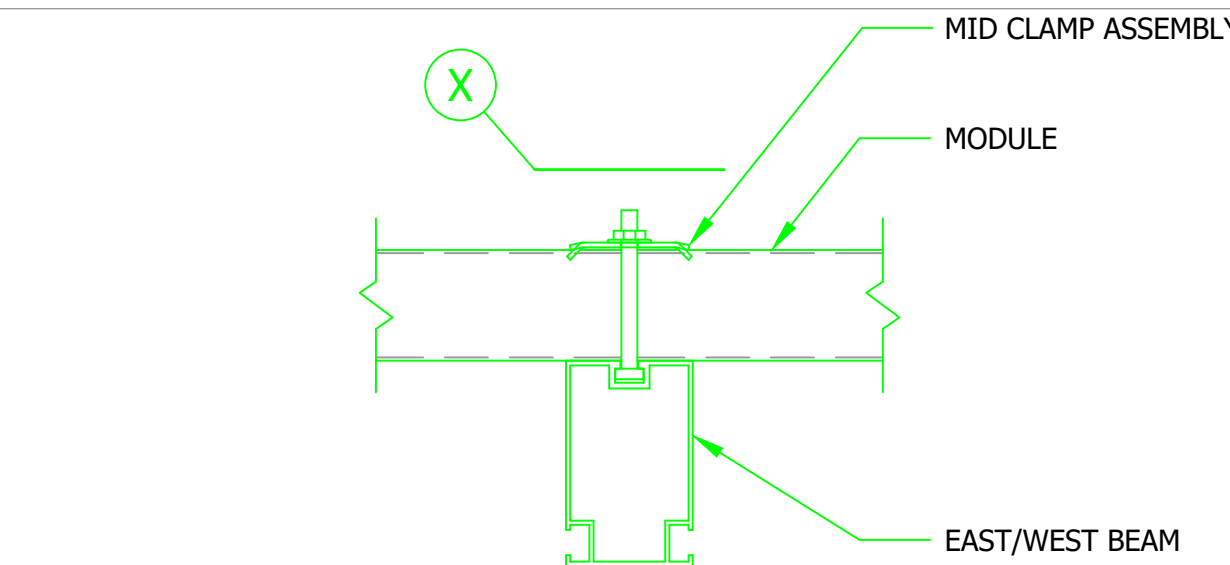

501 MODULE TO EAST/WEST BEAM CONNECTION
(BONDING MID CLAMP)

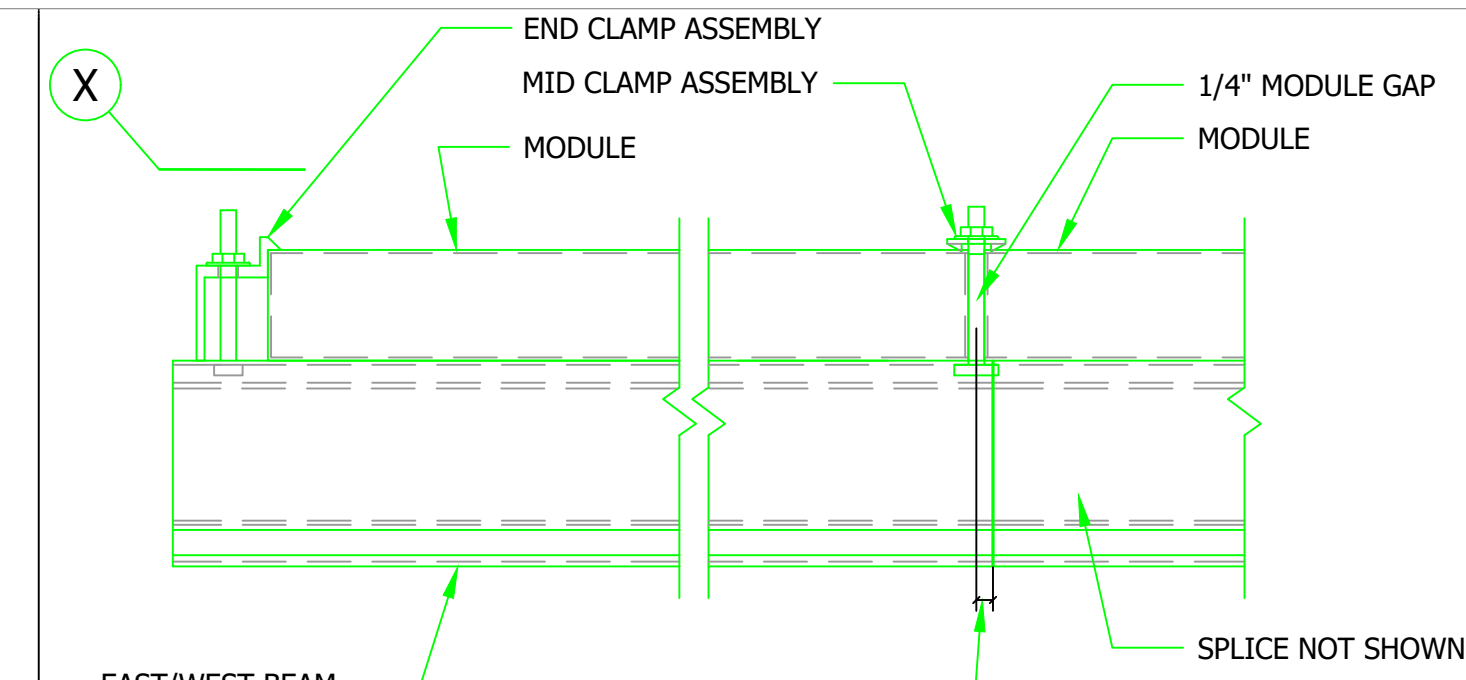

502 MODULE TO EAST/WEST BEAM CONNECTION
(END CLAMP)

NOTE:
CENTERLINE OF T-BOLT SHALL NOT BE CLOSER THAN 1/4" FROM AN EAST/WEST BEAM SPLICE. SHIFT FIRST MODULE LOCATION ON EAST/WEST BEAM AS REQ'D TO AVOID THIS SPLICE CONFLICT.

| REVISION BLOCK | | |
|----------------|-----------|------------------------|
| MARK | DATE | DESCRIPTION |
| 0 | 9/30/2016 | ORIGINAL RELEASE |
| 1 | 10/19/16 | NOTE & BRACE REVISIONS |
| 2 | 1/06/2017 | ADDED SD-200 |
| 3 | 2/02/2017 | REVISED NOTES |
| 4 | 2/13/2017 | REVISED NOTES & SD-300 |

OWNER/CLIENT:

ENGINEERING CONSULTANT:
Design Optimization Technologies
424 Jefferson Street
St. Charles, Mo 63301
Phone: (636) 724-9872
www.DOTecEngineering.com

PROFESSIONAL SEAL

SEE STATE SPECIFIC STAMPED & SIGNED GFT CERTIFICATION LETTER

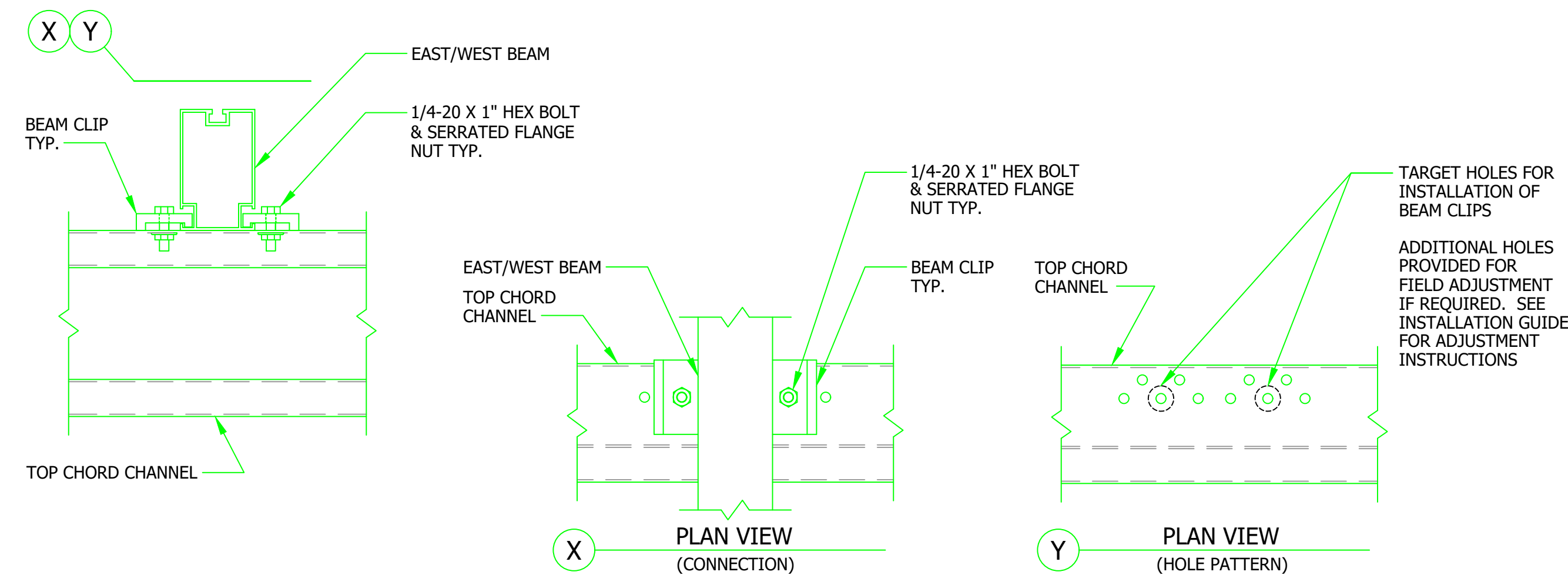

503 EAST/WEST BEAM TO TOP CHORD CONNECTION

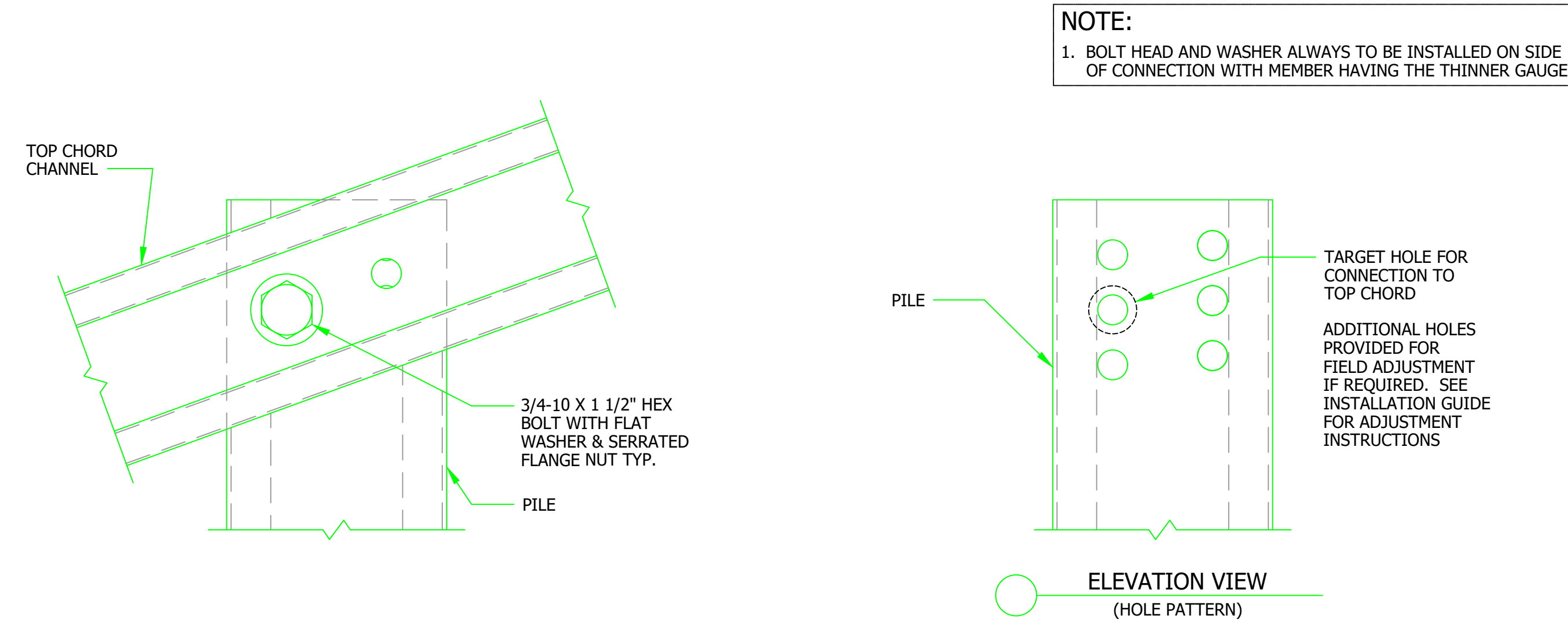

504 TOP CHORD TO PILE CONNECTION

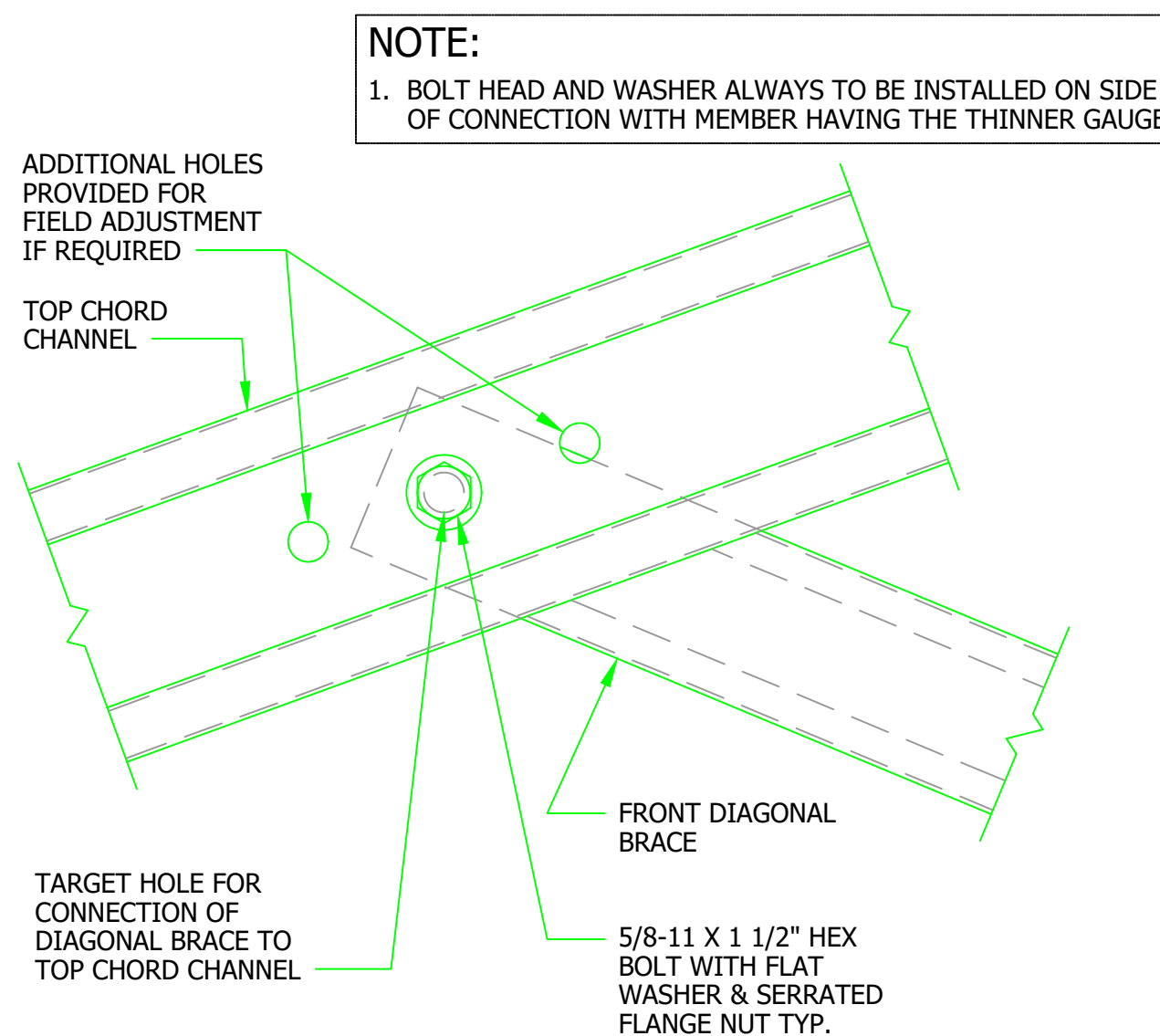

505 TOP CHORD TO DIAGONAL BRACE CONNECTION
(FRONT BRACE)

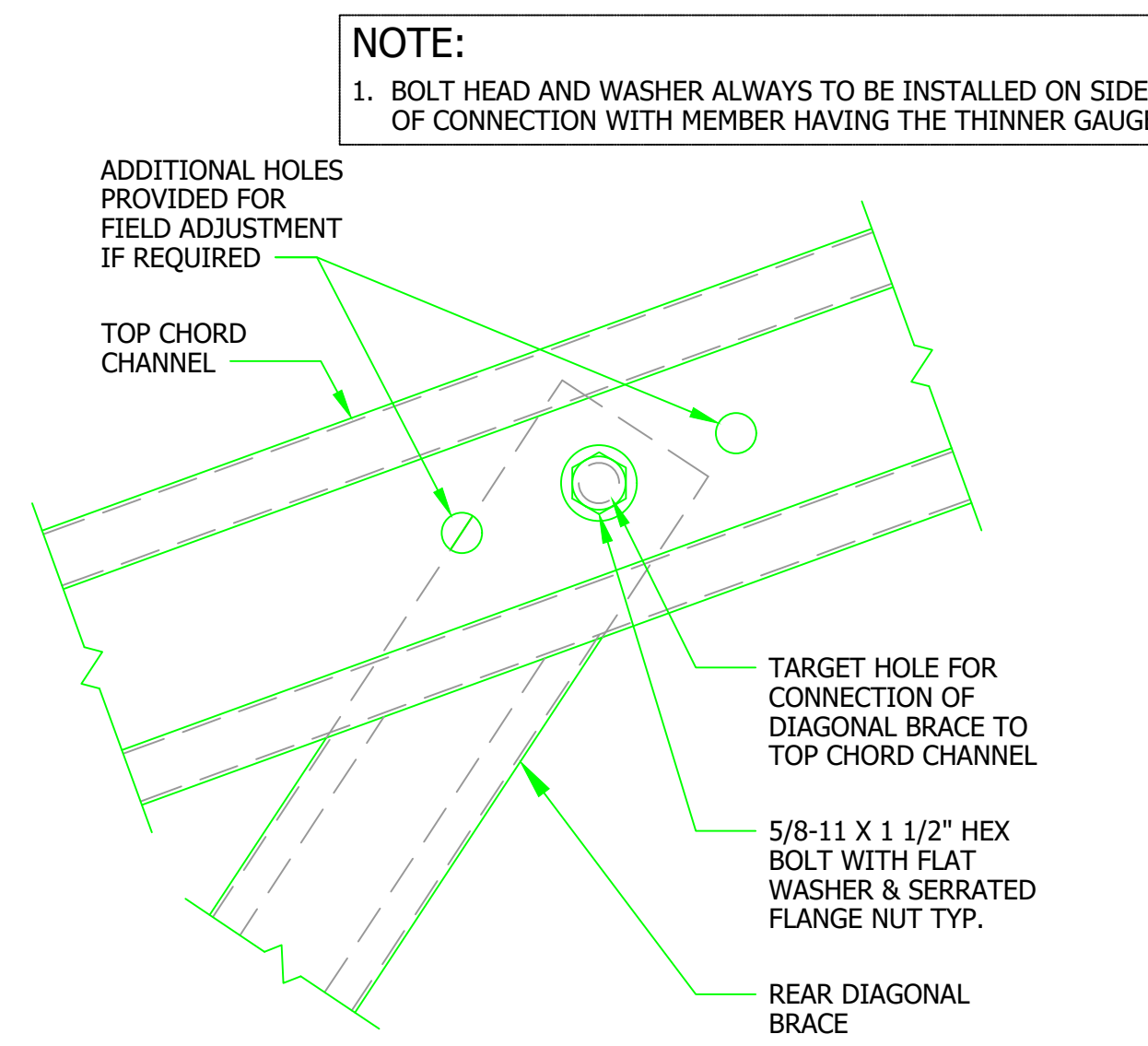

506 TOP CHORD TO DIAGONAL BRACE CONNECTION
(REAR BRACE)

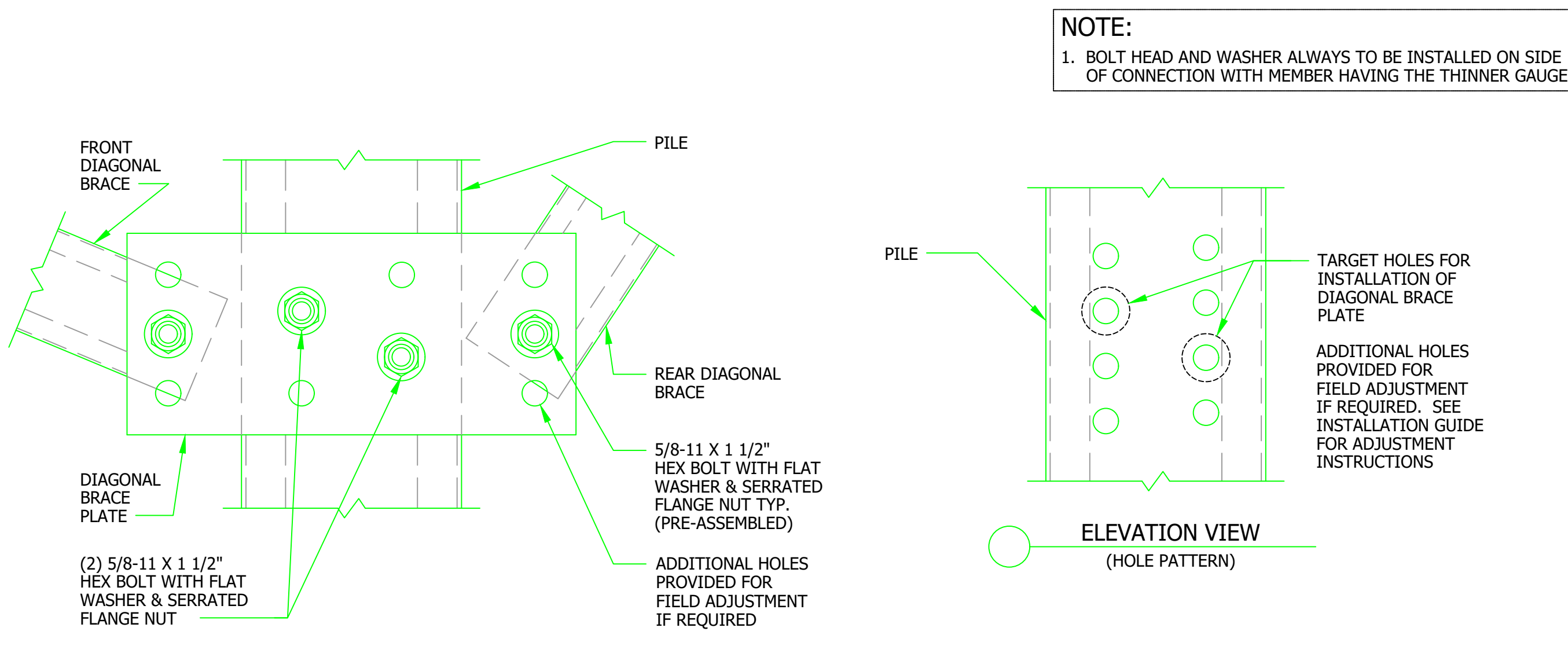

507 DIAGONAL BRACE TO PILE CONNECTION

UNIRAC'S DGFT DISTRIBUTION GROUND FIXED TILT STRUCTURAL RACKING DRAWINGS

UNIRAC
1411 Broadway Boulevard, NE
Albuquerque, New Mexico 87102
Phone: (505) 242-6411
Fax: (505) 242-6412
www.unirac.com

ALL INFORMATION PROVIDED HEREIN IS CONFIDENTIAL AND PROPRIETARY AND IS SOLE PROPERTY OF UNIRAC, INC. REPRODUCTION AND DISTRIBUTION OF THIS DOCUMENT WITHOUT THE WRITTEN CONSENT OF UNIRAC, INC. IS STRICTLY PROHIBITED.

| | |
|------------------------|-----------|
| PROJECT NUMBER: | DGFT |
| ENGINEERED BY: | Jim S |
| DRAFTED BY: | Jeff H |
| REVIEWED BY: | Jeff H |
| ORIGINAL RELEASE DATE: | 9/30/2016 |
| DRAWING SHEET SIZE: | D - 24x36 |

SHEET TITLE
RACKING DETAILS

SHEET NUMBER
SD-500 SHEET
4 of 5