

SITE INFORMATION:

PROPERTY AREA: LOT 1 AREA = 105,917 S.F. (2.43 ACRES).
 LOT 2 AREA = 32,258 S.F. (0.74 ACRES).

EXISTING ZONING: C-3
 PROPOSED ZONING: C-3
 PROPOSED USE: HOTEL

SETBACKS: BUILDING: FRONT = 0'
 SIDE = 0'
 REAR = 0'

PAVEMENT: FRONT = 5'
 SIDE = 5'
 REAR = 5'

PROPOSED BUILDING HEIGHT 55' (MAX. HEIGHT 160')

PARKING REQUIRED: NONE PER REDEVELOPMENT

PARKING PROVIDED: 127 SPACES (5 H.C. ACCESSIBLE)
 BIKE PARKING PROVIDED: 1/10 SPACES (13 REQUIRED/PROVIDED)
 HANDICAP STALLS REQUIRED: 5, HANDICAP STALLS PROVIDED: 5
 LANDSCAPE REQUIREMENTS: MIN. LANDSCAPE SURFACE RATIO: 15%
 MIN. INTERIOR LANDSCAPING: 10%
 PARKING LOT PORTION (MAX 75% OF LOT)

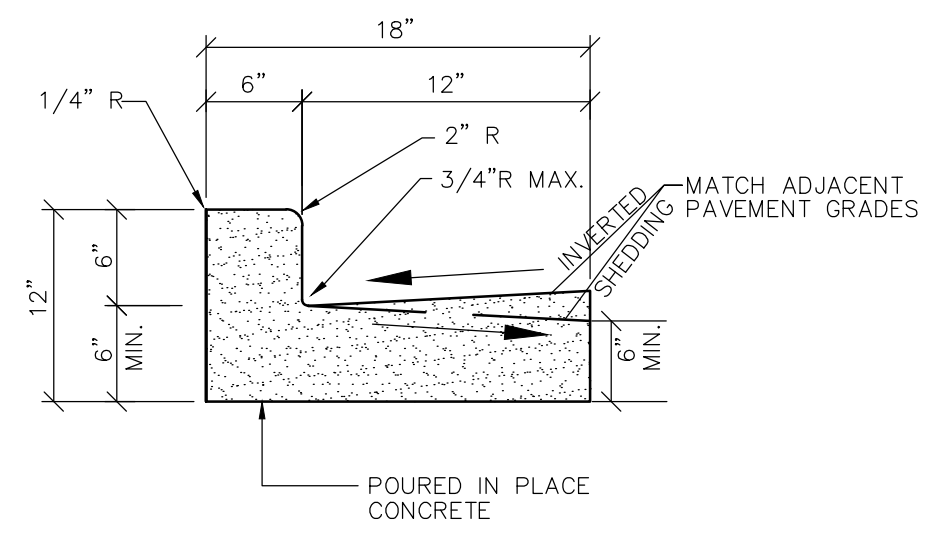

18" CONCRETE CURB & GUTTER DETAIL
 NO SCALE

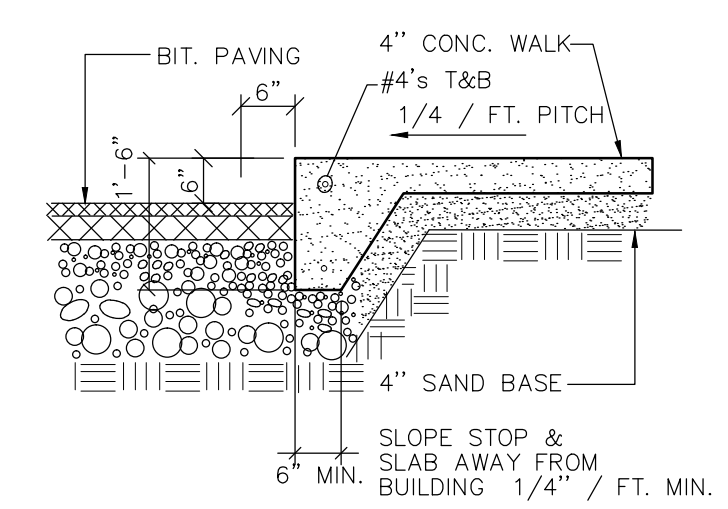

RAISED WALK DETAIL
 NO SCALE

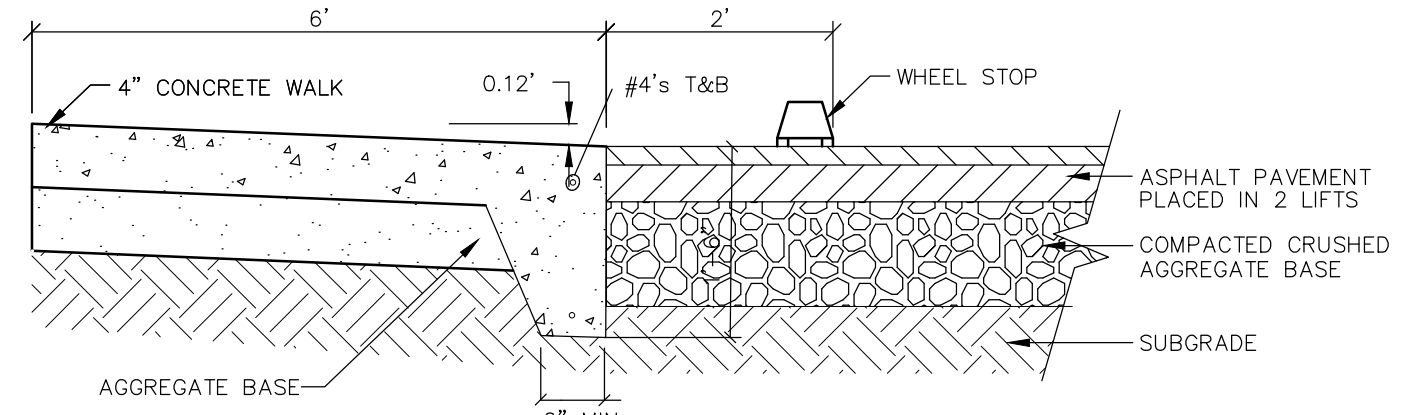

PARKING/WALK DETAIL
 NO SCALE

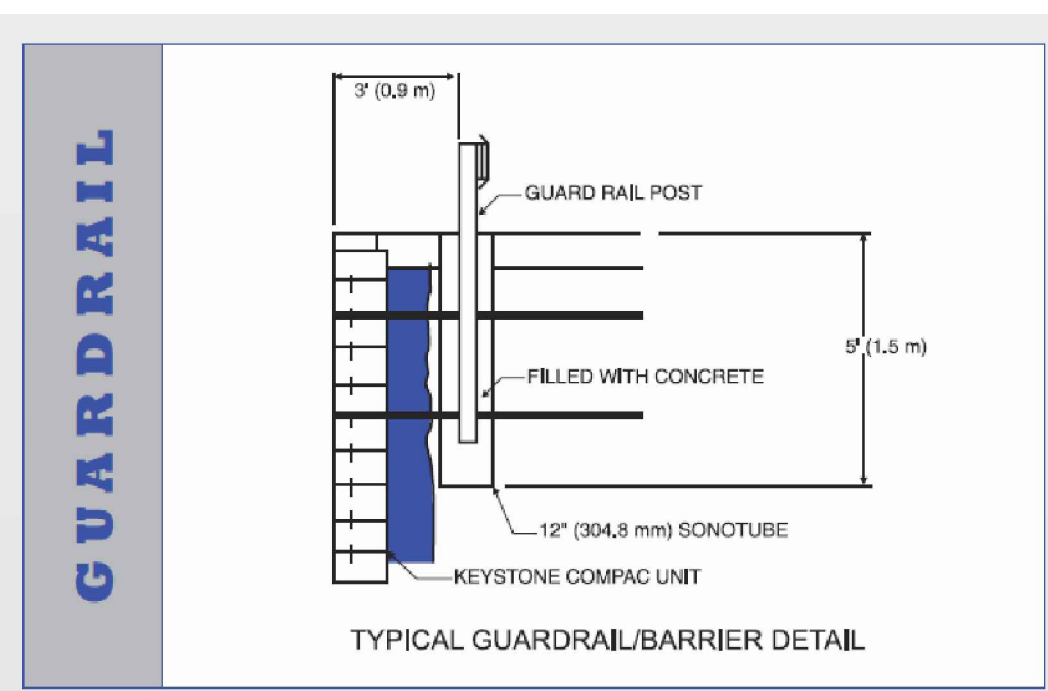

KEYSTEEL RETAINING WALL SYSTEM

EXISTING SITE DATA (LOT 1 & LOT 2)

	AREA (AC)	AREA (SF)	RATIO
PROJECT SITE	3.17	210,509	75.4%
BUILDING FLOOR AREA	2.39	104,133	21.1%
PAVEMENT (ASP. & CONC.)	0.67	101,376	96.5%
TOTAL IMPERVIOUS	3.06	205,509	3.5%
LANDSCAPE/OPEN SPACE	0.11	5,000	

PROPOSED SITE DATA (LOT 1)

	AREA (AC)	AREA (SF)	RATIO
PROJECT SITE	2.43	105,917	17.0%
BUILDING FLOOR AREA	0.41	18,025	54.5%
PAVEMENT (ASP. & CONC.)	1.33	57,724	71.5%
TOTAL IMPERVIOUS	1.74	75,749	28.5%
LANDSCAPE/OPEN SPACE	0.69	30,168	

LOT 2

	AREA (AC)	AREA (SF)	RATIO
PROJECT SITE	0.74	32,258	100%
EXISTING IMPERVIOUS	0.74	32,258	0%
PROPOSED IMPERVIOUS	0	0	

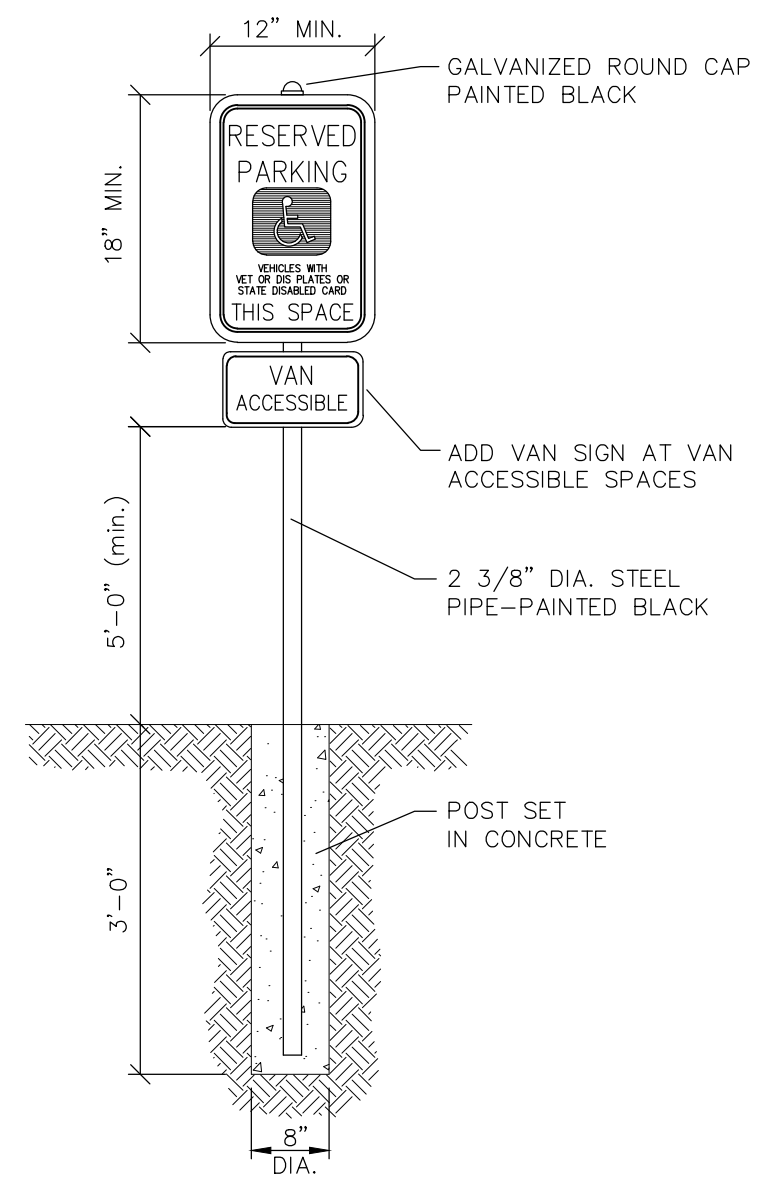

HANDICAP SIGNAGE DETAIL
 NO SCALE

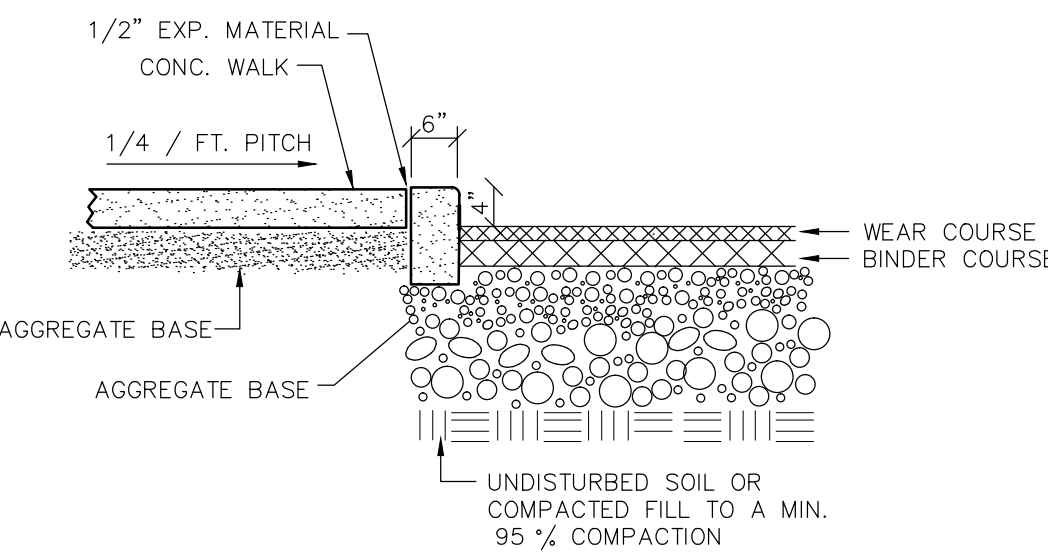

RAISED WALK W/ CURB
 NO SCALE

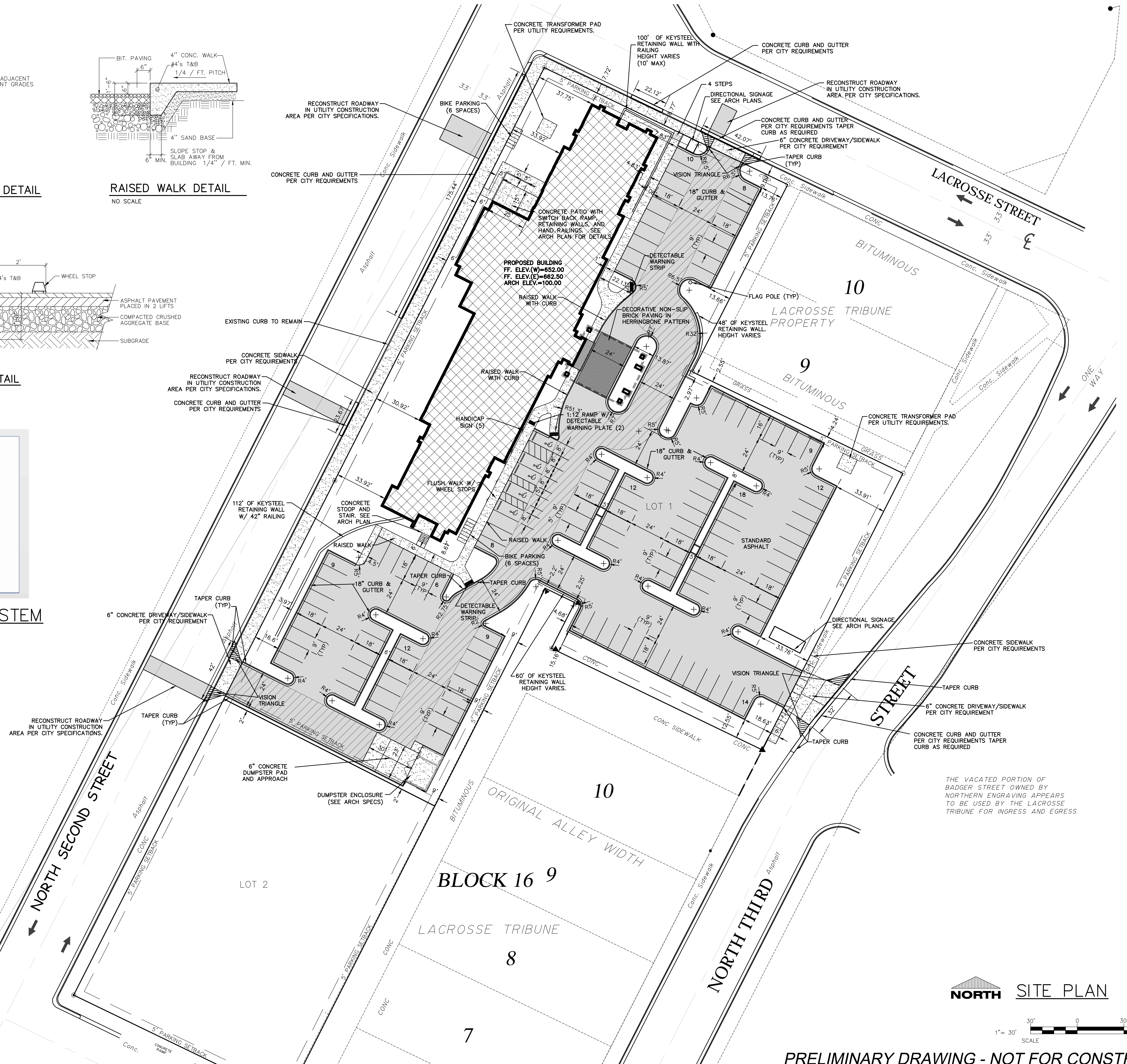
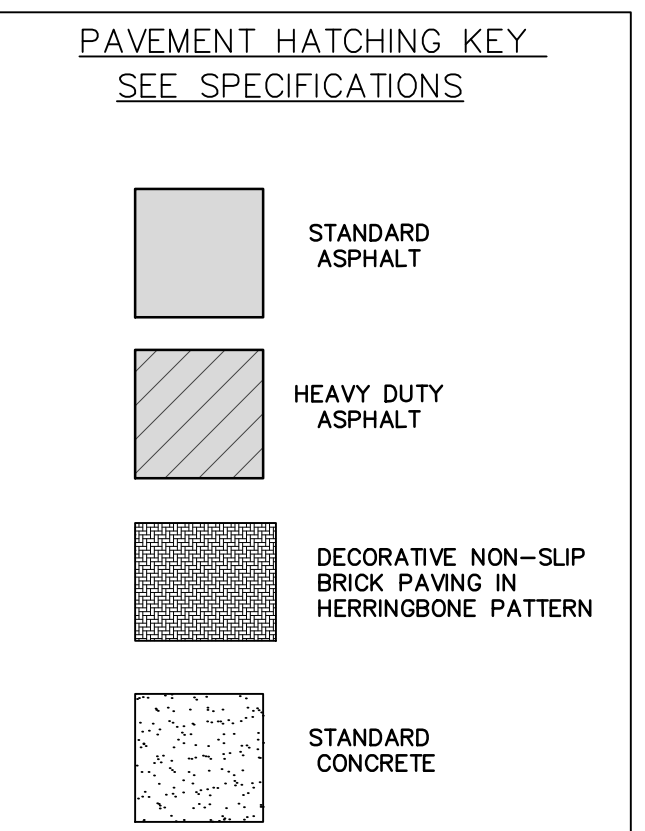

PRELIMINARY DRAWING - NOT FOR CONSTRUCTION

OWNER:
 LA CROSSE HOTEL GROUP, LLC
 115 E. MAIN STREET, SUITE 210
 MADISON, WI 53703

PROJECT:
 HAMPTON INN & SUITES
 N. 3RD AND LA CROSSE ST.
 LA CROSSE, WI

PRELIMINARY SHEET DATES:
 MARCH 18, 2014
 APRIL 4, 2014

JOB NUMBER:
 1402940
SHEET

C1.2