

PRELIMINARY  
NOT FOR CONSTRUCTION

CURRENT ZONING: PUD GENERAL			
PROPOSED USE: PUD SPECIFIC			
TOTAL BUILDING AREA: 18,962 SF			
TOTAL UNITS: 32			
2-BEDROOM UNITS: 16			
1-BEDROOM UNITS: 16			
TOTAL BEDROOMS: 48			
CONDITION	IMPERVIOUS	PERVIOUS	TOTAL
EXISTING	0.00 ACRE	1.59 ACRE	1.59 ACRE
PROPOSED	1.00 ACRE	0.59 ACRE	1.59 ACRE
ADJACENT	LAND USES		
SOUTH	AGRICULTURE		
WEST	PLANNED DEVELOPMENT DISTRICT		
NORTH	PLANNED DEVELOPMENT DISTRICT		
EAST	STATE HWY35 RIGHT OF WAY		
OFF-STREET PARKING REQUIRED	48 STALLS		
OFF-STREET PARKING PROVIDED	49 STALLS		
ADA PARKING PROVIDED	2 STALLS		
ADA VAN PARKING PROVIDED	2 STALLS		

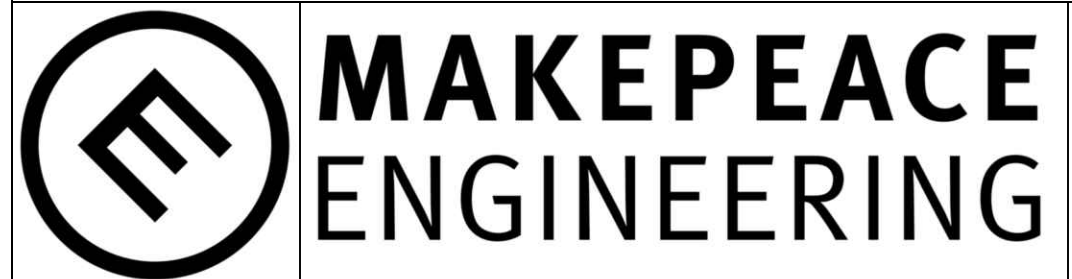

200 MASON ST #3  
ONALASKA, WI 54650  
608.881.6030

NICK ROUSH  
WATERVIEW ADDITION  
LA CROSSE, WI

03/05/2020

SITE PLAN

DATE	REVISION	DESCR.

C101



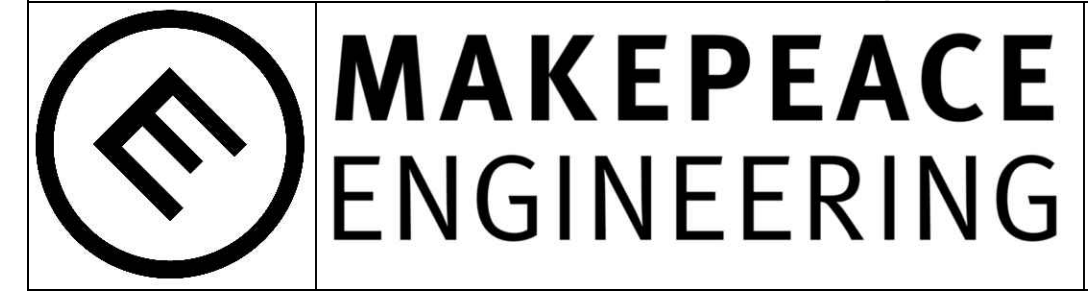
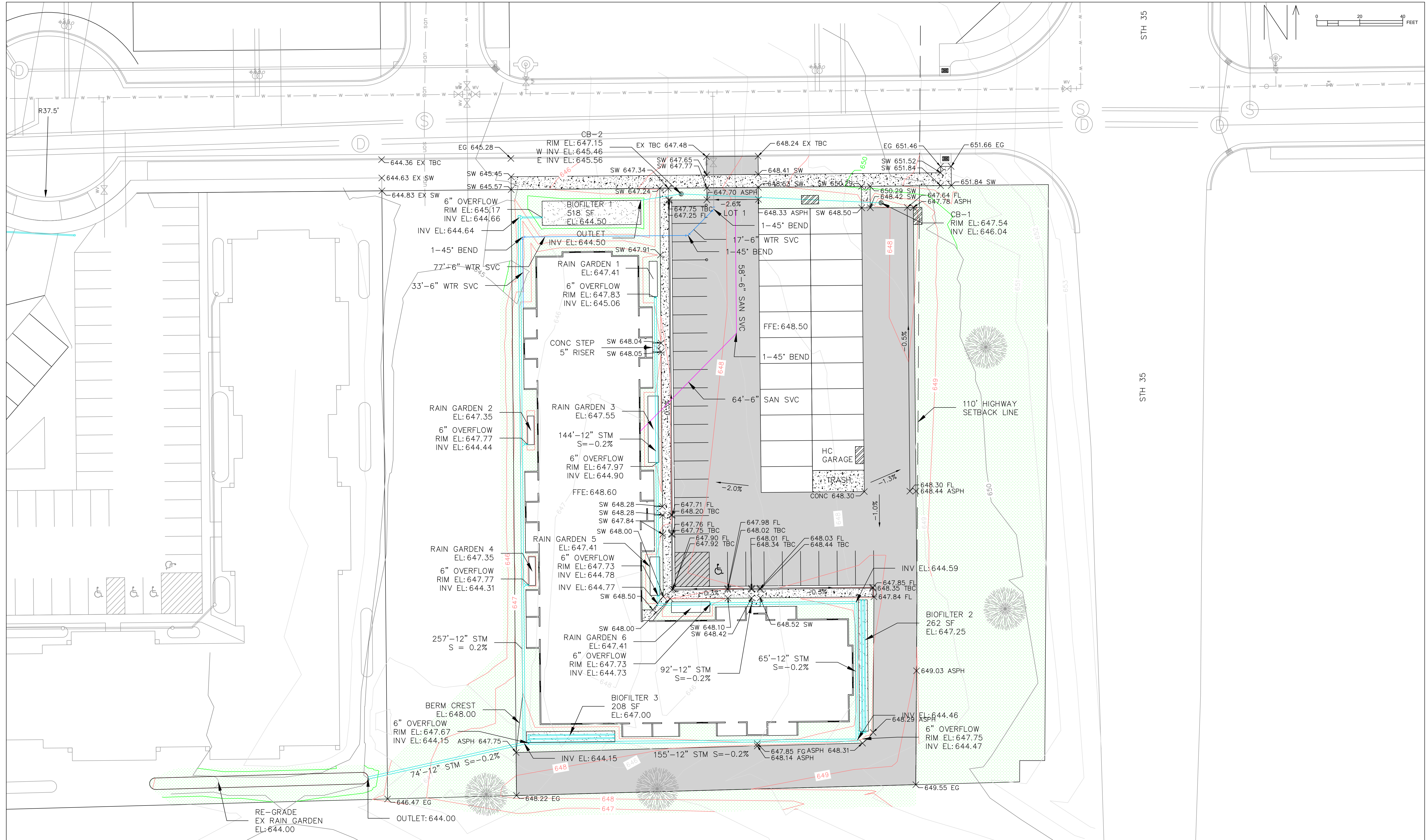

200 MASON ST. #3  
 ONALASKA, WI 54650  
 608.797.1025

NICK ROUSH  
 WATERVIEW ADDITION  
 LA CROSSE, WI

03/05/2020

# GRADING PLAN - LOT 1

DATE	REVISION	DESCR.

C102



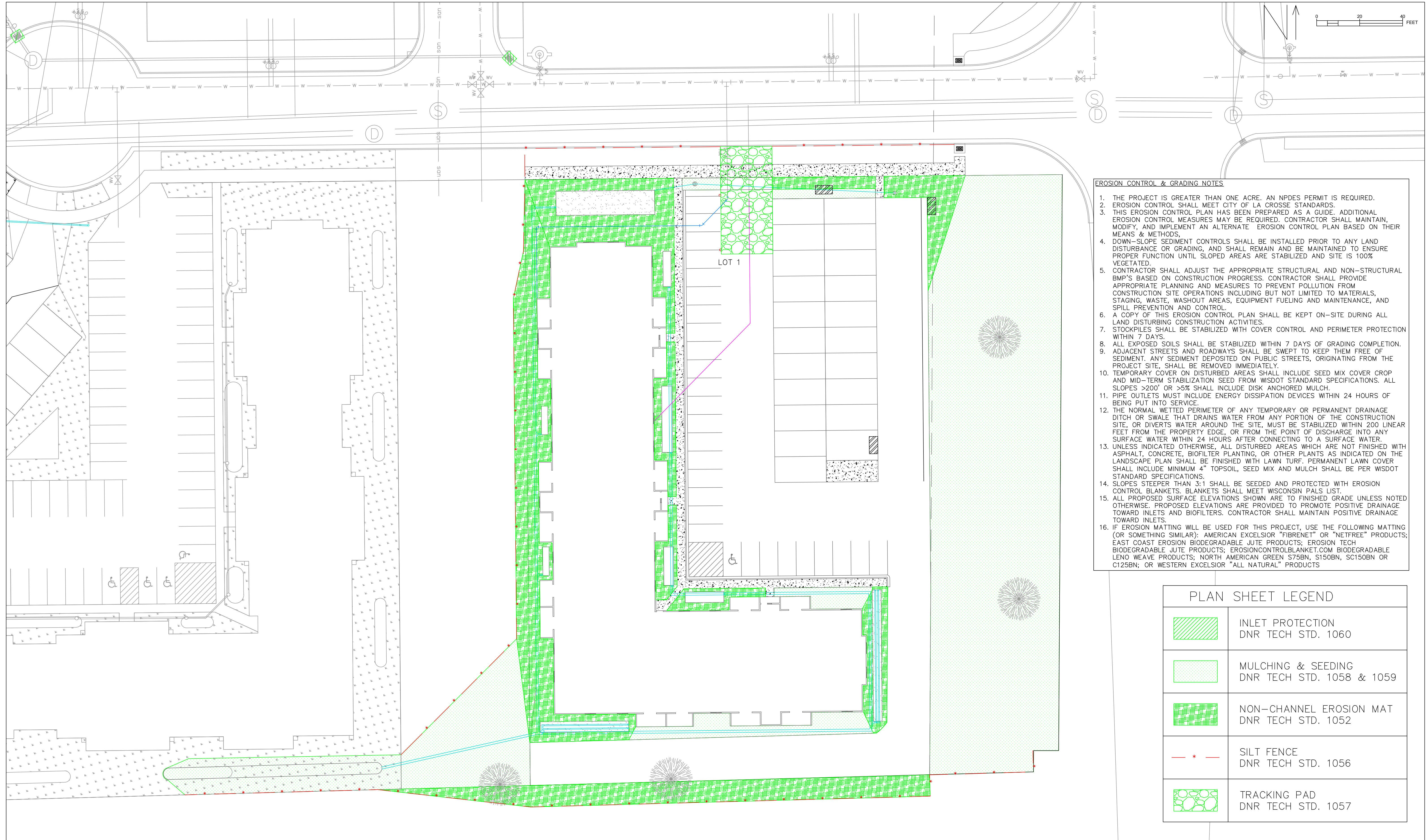

**EROSION CONTROL & GRADING NOTES**

1. THE PROJECT IS GREATER THAN ONE ACRE. AN NPDES PERMIT IS REQUIRED.
2. EROSION CONTROL SHALL MEET CITY OF LA CROSSE STANDARDS.
3. THIS EROSION CONTROL PLAN HAS BEEN PREPARED AS A GUIDE. ADDITIONAL EROSION CONTROL MEASURES MAY BE REQUIRED. CONTRACTOR SHALL MAINTAIN, MODIFY, AND IMPLEMENT AN ALTERNATE EROSION CONTROL PLAN BASED ON THEIR MEANS & METHODS.
4. DOWN-SLOPE SEDIMENT CONTROLS SHALL BE INSTALLED PRIOR TO ANY LAND DISTURBANCE OR GRADING, AND SHALL REMAIN AND BE MAINTAINED TO ENSURE PROPER FUNCTION UNTIL SLOPED AREAS ARE STABILIZED AND SITE IS 100% VEGETATED.
5. CONTRACTOR SHALL ADJUST THE APPROPRIATE STRUCTURAL AND NON-STRUCTURAL BMP'S BASED ON CONSTRUCTION PROGRESS. CONTRACTOR SHALL PROVIDE APPROPRIATE PLANNING AND MEASURES TO PREVENT POLLUTION FROM CONSTRUCTION SITE OPERATIONS INCLUDING BUT NOT LIMITED TO MATERIALS, STAGING, WASTE, WASHOUT AREAS, EQUIPMENT FUELING AND MAINTENANCE, AND SPILL PREVENTION AND CONTROL.
6. A COPY OF THIS EROSION CONTROL PLAN SHALL BE KEPT ON-SITE DURING ALL LAND DISTURBING CONSTRUCTION ACTIVITIES.
7. STOCKPILES SHALL BE STABILIZED WITH COVER CONTROL AND PERIMETER PROTECTION WITHIN 7 DAYS.
8. ALL EXPOSED SOILS SHALL BE STABILIZED WITHIN 7 DAYS OF GRADING COMPLETION.
9. ADJACENT STREETS AND ROADWAYS SHALL BE SWEEPED TO KEEP THEM FREE OF SEDIMENT. ANY SEDIMENT DEPOSITED ON PUBLIC STREETS, ORIGINATING FROM THE PROJECT SITE, SHALL BE REMOVED IMMEDIATELY.
10. TEMPORARY COVER ON DISTURBED AREAS SHALL INCLUDE SEED MIX COVER CROP AND MID-TERM STABILIZATION SEED FROM WISDOT STANDARD SPECIFICATIONS. ALL SLOPES >20' OR >5% SHALL INCLUDE DISK ANCHORED MULCH.
11. PIPE OUTLETS MUST INCLUDE ENERGY DISSIPATION DEVICES WITHIN 24 HOURS OF BEING PUT INTO SERVICE.
12. THE NORMAL WETTED PERIMETER OF ANY TEMPORARY OR PERMANENT DRAINAGE DITCH OR SWALE THAT DRAINS WATER FROM ANY PORTION OF THE CONSTRUCTION SITE, OR DIVERTS WATER AROUND THE SITE, MUST BE STABILIZED WITHIN 200 LINEAR FEET FROM THE PROPERTY EDGE, OR FROM THE POINT OF DISCHARGE INTO ANY SURFACE WATER WITHIN 24 HOURS AFTER CONNECTING TO A SURFACE WATER.
13. UNLESS INDICATED OTHERWISE, ALL DISTURBED AREAS WHICH ARE NOT FINISHED WITH ASPHALT, CONCRETE, BIOFILTER PLANTING, OR OTHER PLANTS AS INDICATED ON THE LANDSCAPE PLAN SHALL BE FINISHED WITH LAWN TURF. PERMANENT LAWN COVER SHALL INCLUDE MINIMUM 4" TOPSOIL, SEED MIX AND MULCH SHALL BE PER WISDOT STANDARD SPECIFICATIONS.
14. SLOPES STEEPER THAN 3:1 SHALL BE SEEDED AND PROTECTED WITH EROSION CONTROL BLANKETS. BLANKETS SHALL MEET WISCONSIN PALS LIST.
15. ALL PROPOSED SURFACE ELEVATIONS SHOWN ARE TO FINISHED GRADE UNLESS NOTED OTHERWISE. PROPOSED ELEVATIONS ARE PROVIDED TO PROMOTE POSITIVE DRAINAGE TOWARD INLETS AND BIOFILTERS. CONTRACTOR SHALL MAINTAIN POSITIVE DRAINAGE TOWARD INLETS.
16. IF EROSION MATTING WILL BE USED FOR THIS PROJECT, USE THE FOLLOWING MATTING (OR SOMETHING SIMILAR): AMERICAN EXCELSIOR "FIBRENET" OR "NETFREE" PRODUCTS; EAST COAST EROSION BIODEGRADABLE JUTE PRODUCTS; EROSION TECH BIODEGRADABLE JUTE PRODUCTS; EROSIONCONTROLBLANKET.COM BIODEGRADABLE LENO WEAVE PRODUCTS; NORTH AMERICAN GREEN S75BN, S150BN, SC150BN OR C125BN; OR WESTERN EXCELSIOR "ALL NATURAL" PRODUCTS

PLAN SHEET LEGEND	
	INLET PROTECTION DNR TECH STD. 1060
	MULCHING & SEEDING DNR TECH STD. 1058 & 1059
	NON-CHANNEL EROSION MAT DNR TECH STD. 1052
	SILT FENCE DNR TECH STD. 1056
	TRACKING PAD DNR TECH STD. 1057



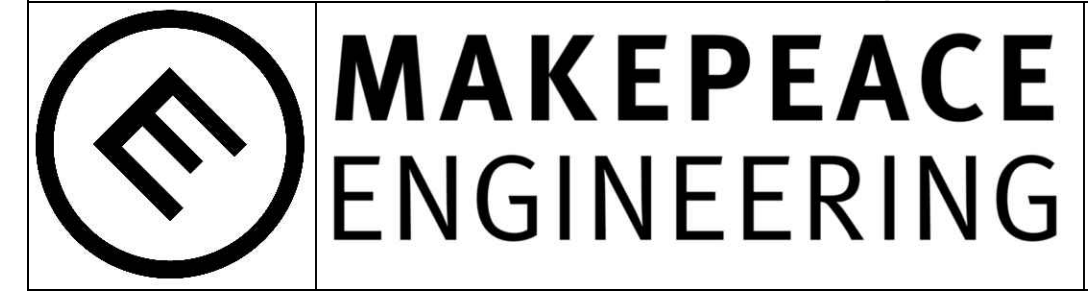
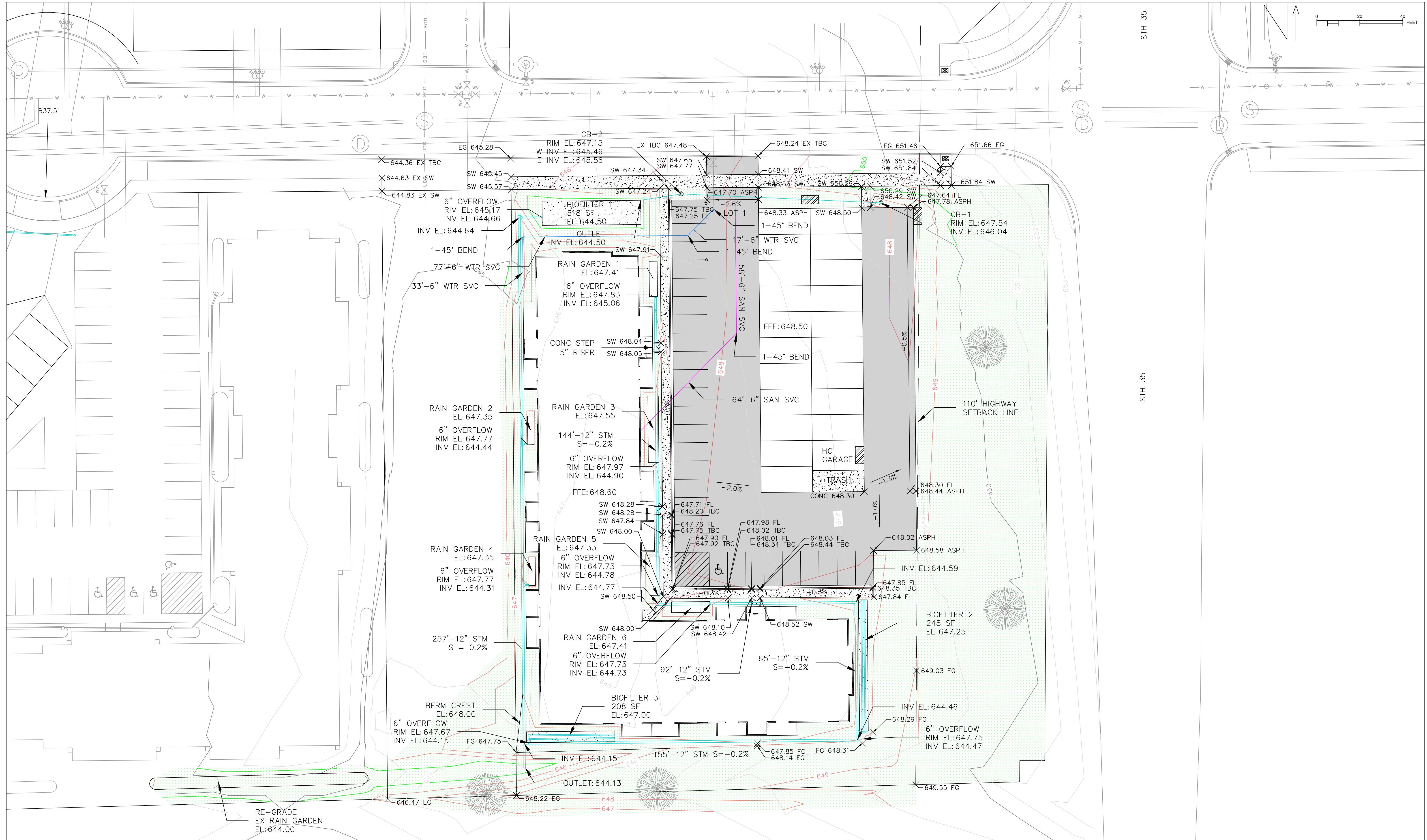

200 MASON ST. #3  
 ONALASKA, WI 54650  
 608.797.1025

NICK ROUSH  
 WATERVIEW ADDITION  
 LA CROSSE, WI

03/05/2020

# GRADING PLAN - PHASE 1

DATE	REVISION	DESCR.

C104



# BIOFILTER

CONCEPTUAL DRAWING ONLY.  
SHOWN OUT OF PROJECTION.

ADJACENT MATERIALS, SLOPE, & ELEVATION VARIES. SEE SITE PLAN.

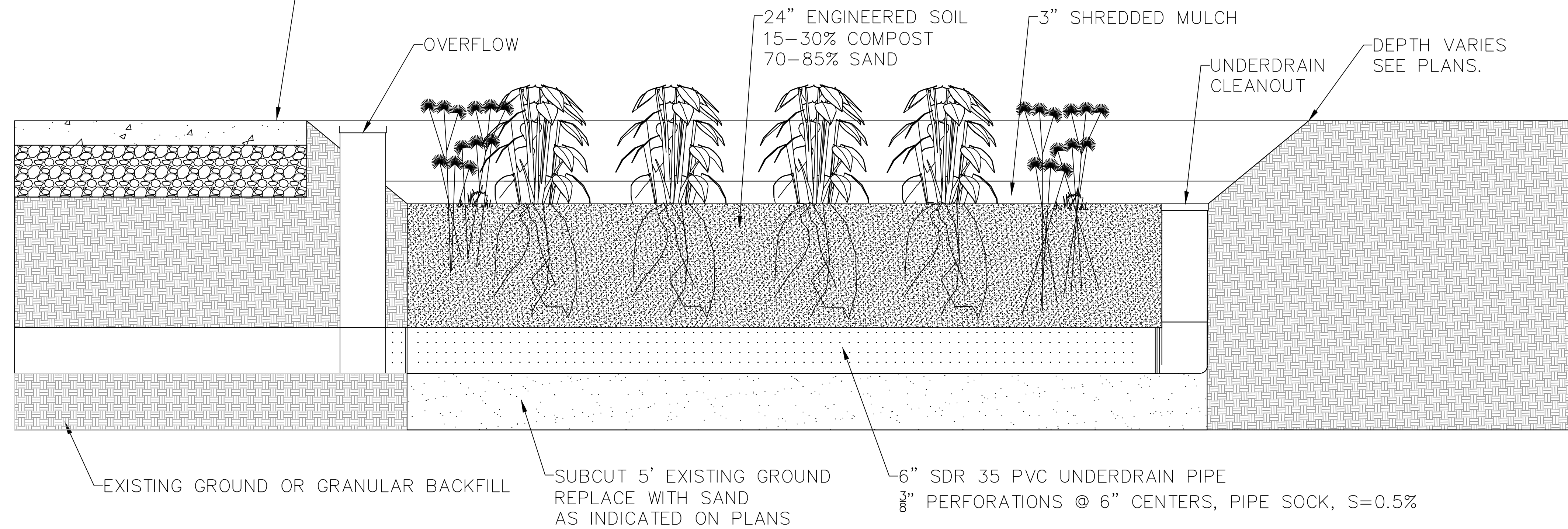

- CONSTRUCT BIOFILTER IN ACCORDANCE WITH WDNR TECHNICAL STANDARD 1004
- PROVIDED AS CONCEPT ONLY. ACTUAL INSTALLATION DETAILS FOR ADJACENT MATERIALS VARY AND ARE SHOWN ON THE SITE PLAN.
  - PLANT WITH NATIVE DECORATIVE GRASSES AND PLANTS.
  - PLUGS SHALL BE PLACED 1' ON CENTER.
  - PLANT SELECTION SHALL BE BASED ON ENGINEERED SOIL COMPOSITION AS WELL AS NATIVE SOIL CONDITIONS BENEATH THE ENGINEERED SOIL LAYER.
  - SELECTED PLANTS SHALL BE DEEP ROOTED.
  - SELECTED PLANTS SHALL BE APPROVED BY OWNER PRIOR TO PLANTING.

## HOT MIX ASPHALT

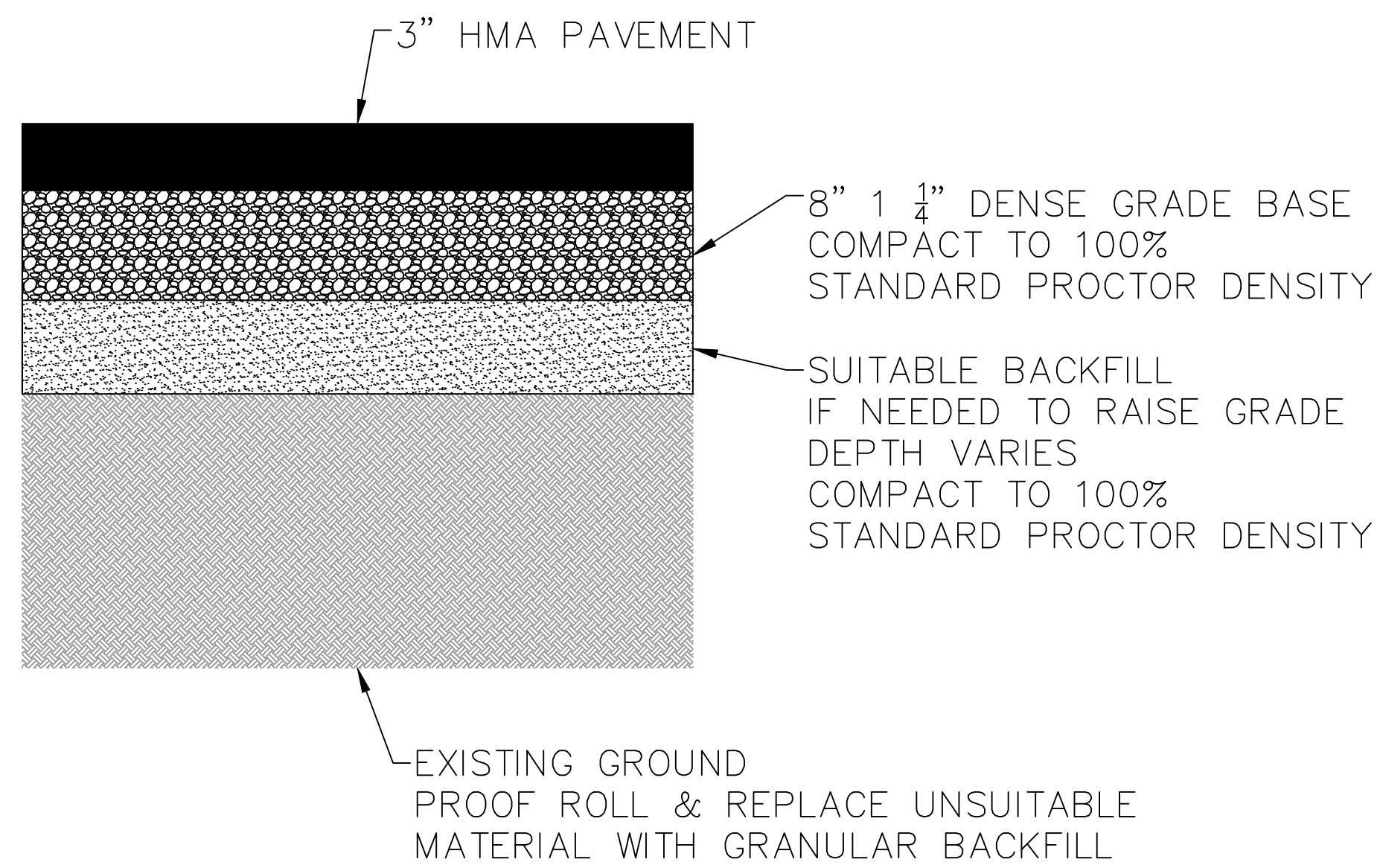

## SIDEWALK

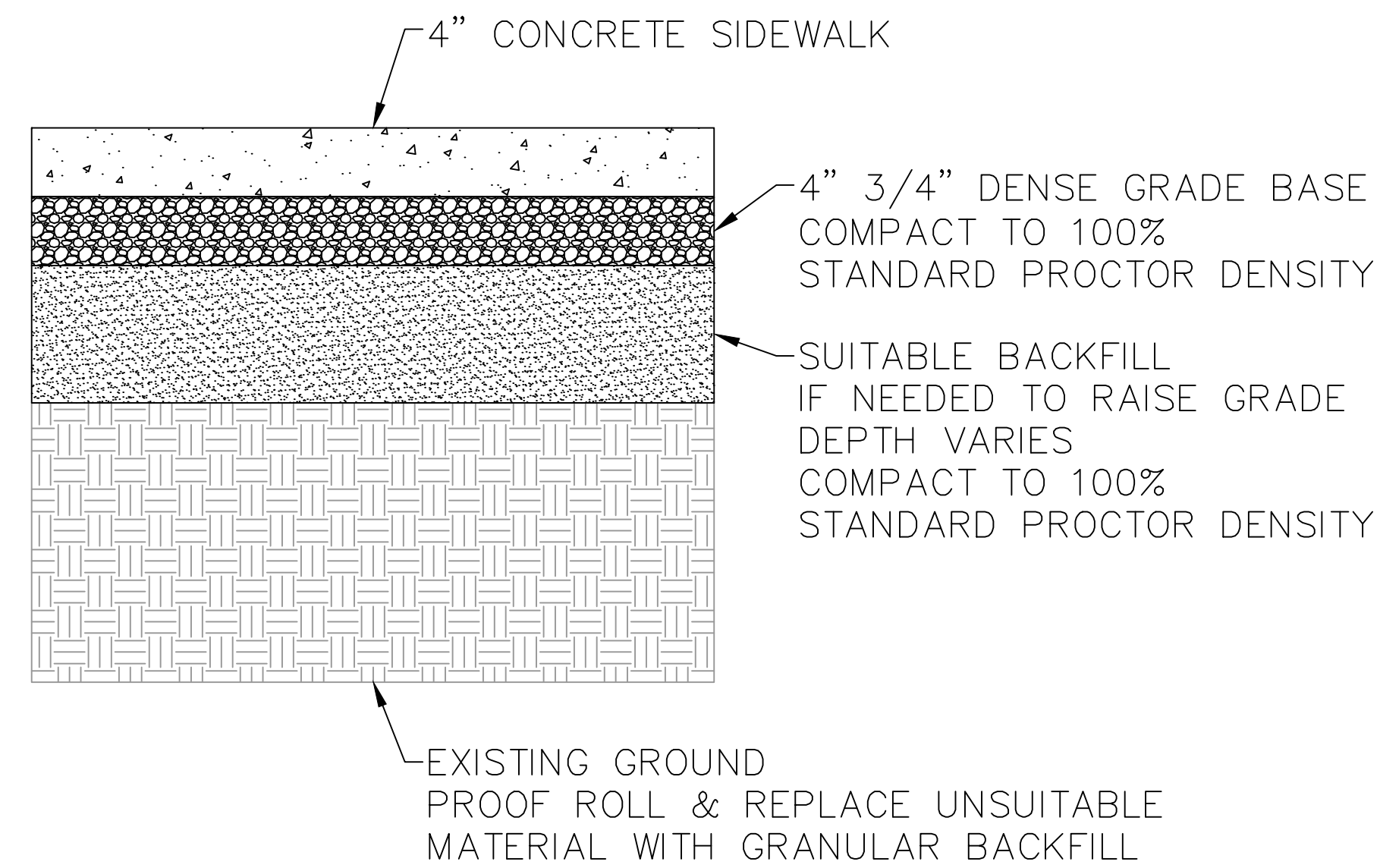

## RAIN GARDEN

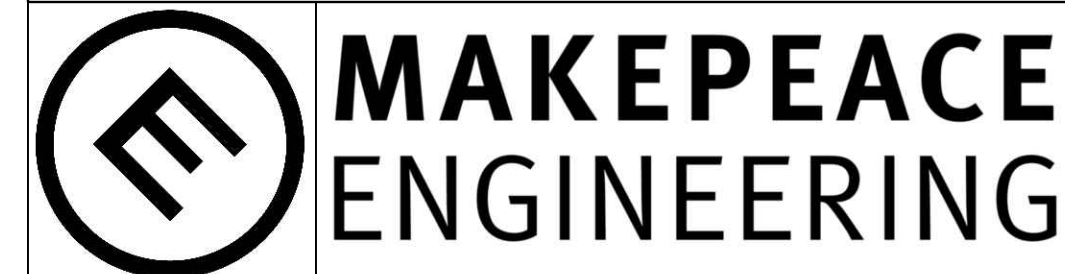
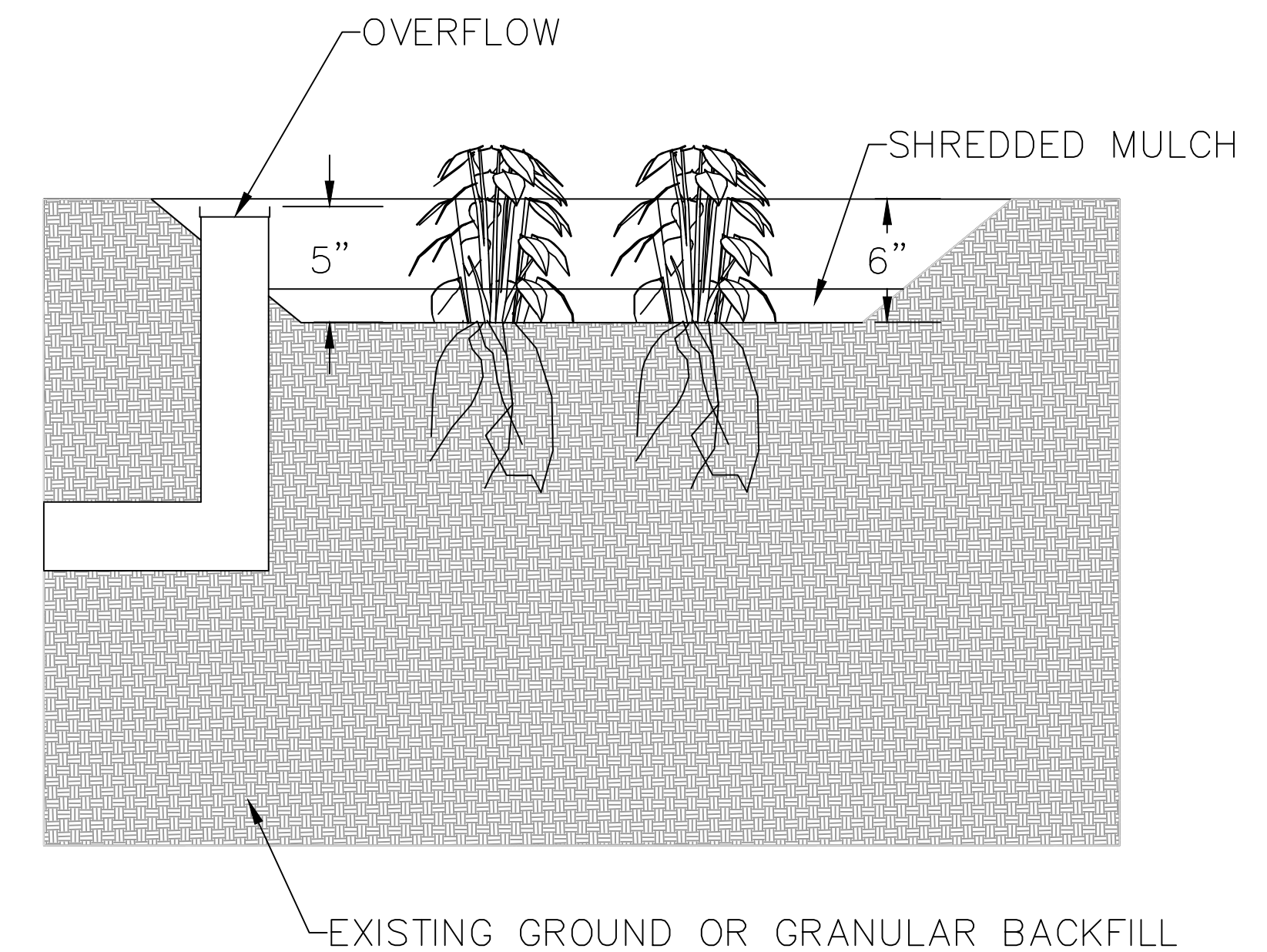

200 MASON ST #3  
ONALASKA, WI 54650  
608.881.6030

NICK ROUSH  
WATERVIEW ADDITION  
LA CROSSE, WI

03/05/2020

CONSTRUCTION DETAILS

DATE	REVISION	DESCR.

C105



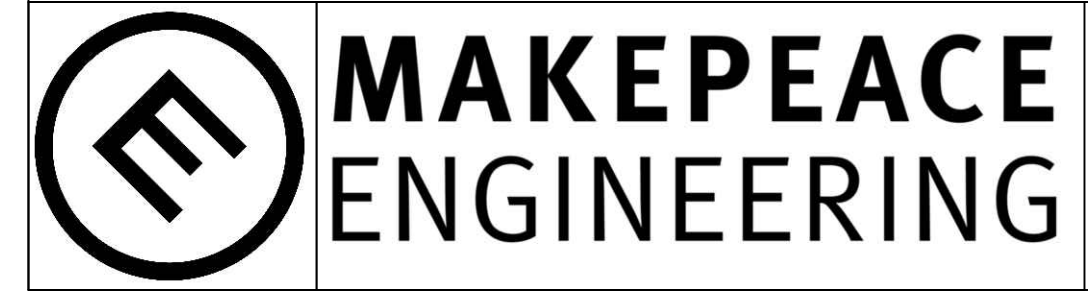
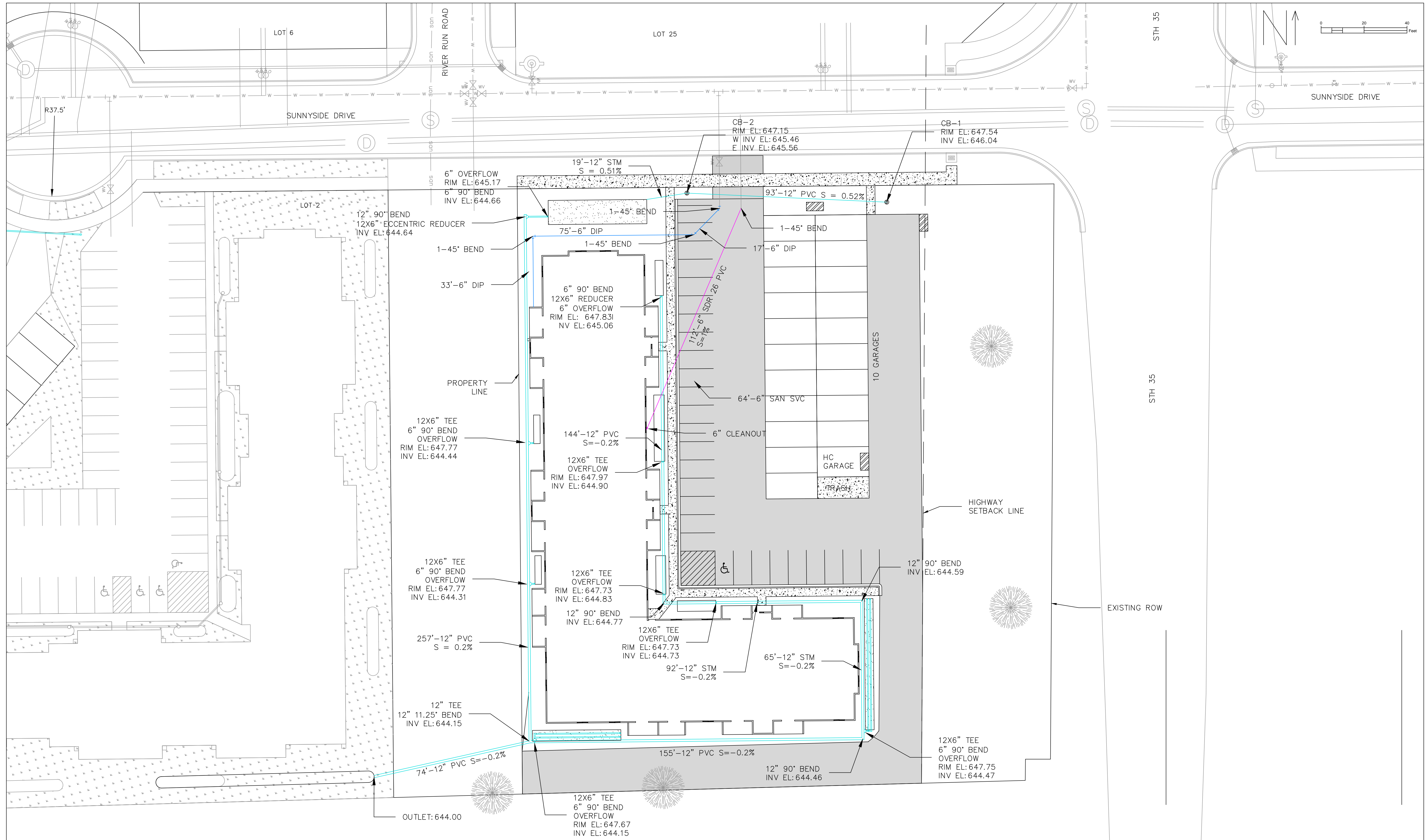

200 MASON ST #3  
 ONALASKA, WI 54650  
 608.881.6030

NICK ROUSH  
 WATERVIEW ADDITION  
 LA CROSSE, WI

03/05/2020

# UTILITY PLAN

DATE	REVISION	DESCR.

C106