

SPECIFICATIONS:

- DIV. 03 CONCRETE:**
 - CONCRETE FOUNDATION WALLS AND FOOTINGS. SEE STRUCTURAL PLANS.
 - CONCRETE STOOPS BROOM FINISH, PEA GRAVEL DRAINAGE FIELD.
 - INTERIOR CONCRETE WATER SEALED, SMOOTH TROWEL FINISH.
- DIV. 04 MASONRY:**
 - SPLIT FACE CMU: 8"x8". BROWN INTEGRAL COLOR AND GROUT TO MATCH EXISTING BUILDING.
- DIV. 05 METALS:**
 - 3" STEEL DECKING. SEE STRUCTURAL. ALL ROOFING FASTENERS ARE TO BE ATTACHED TO TOP FLUTE, 1" MAX.
 - 6" DIA. STEEL PROTECTION BOLLARDS, YELLOW PLASTIC COVER.
 - L3x3x3/16" SUPPORT FOR HUNG COMPONENTS PER PLAN.
- DIV. 06 WOODS:**
 - 1/4" HDPE PANELS
 - BLOCKING AS SHOWN ON PLANS.
 - WOOD IS NOT REQUIRED TO BE FIRE RESISTANT TREATED.
 - WOOD IN CONTACT WITH CMU / CONCRETE TO BE PRESSURE TREATED. PROVIDE SILL SEALER.
- DIV. 07 THERMAL / WATERPROOFING:**
 - TWO-PIECE 22 GA. METAL FASCIA AT ROOF EDGES. BROWN COLOR TO MATCH EXISTING BUILDING.
 - TPO ROOF: FULLY ADHERED, R-30 INSULATION.
 - SEALANT: AT ALL CONCRETE SAW CUTS, CMU CONTROL JOINTS, AND AS INDICATED ON PLANS.
 - WALL INSULATION: R-28 CLOSED CELL SPRAY FOAM
- DIV. 08 DOORS:**
 - MAN DOOR: FIELD PAINTED
 - 4"x7" INSULATED STEEL DOOR.
 - HEAVY DUTY STEEL FRAME W/ 4" MASONRY HEAD. INSULATE.
 - LEVER TYPE STOREROOM LOCK W/ LATCH GUARD.
 - NRP HINGES
 - ACCESSORIES: DRIP CAP, SADDLE THRESHOLD, WEATHER STRIPPING & THRESHOLD SEAL. CLOSER.
- DIV. 09 FINISHES:**
 - 25 GA. INTERIOR METAL FRAMING SIZED PER PLAN.
 - PAINT AS INDICATED ON PLANS.
- DIV. 10 SPECIALTIES:**
 - FIRE EXTINGUISHER COMPLIANT WITH MATERIALS BEING STORED.
 - DRY CHEMICAL FIRE EXTINGUISHING SYSTEM. SEPARATE SUBMITTAL.
- DIV. 22 PLUMBING:**
 - GAS PIPING DESIGN-BUILD. SEE PLANS BY OTHERS.
- DIV. 23 HVAC:**
 - DESIGN-BUILD, SEPARATE SUBMITTAL. SEE PLANS BY OTHERS.
- DIV. 26 ELECTRICAL:**
 - LED VAPOR TIGHT INTERIOR LIGHTS.
 - EMERGENCY AND EXIT LIGHTING TO MEET CODE.
 - DESIGN-BUILD, SEE PLANS BY OTHERS.
- DIV. 27 COMMUNICATIONS:**
 - DESIGN-BUILD, SEE PLANS BY OTHERS.

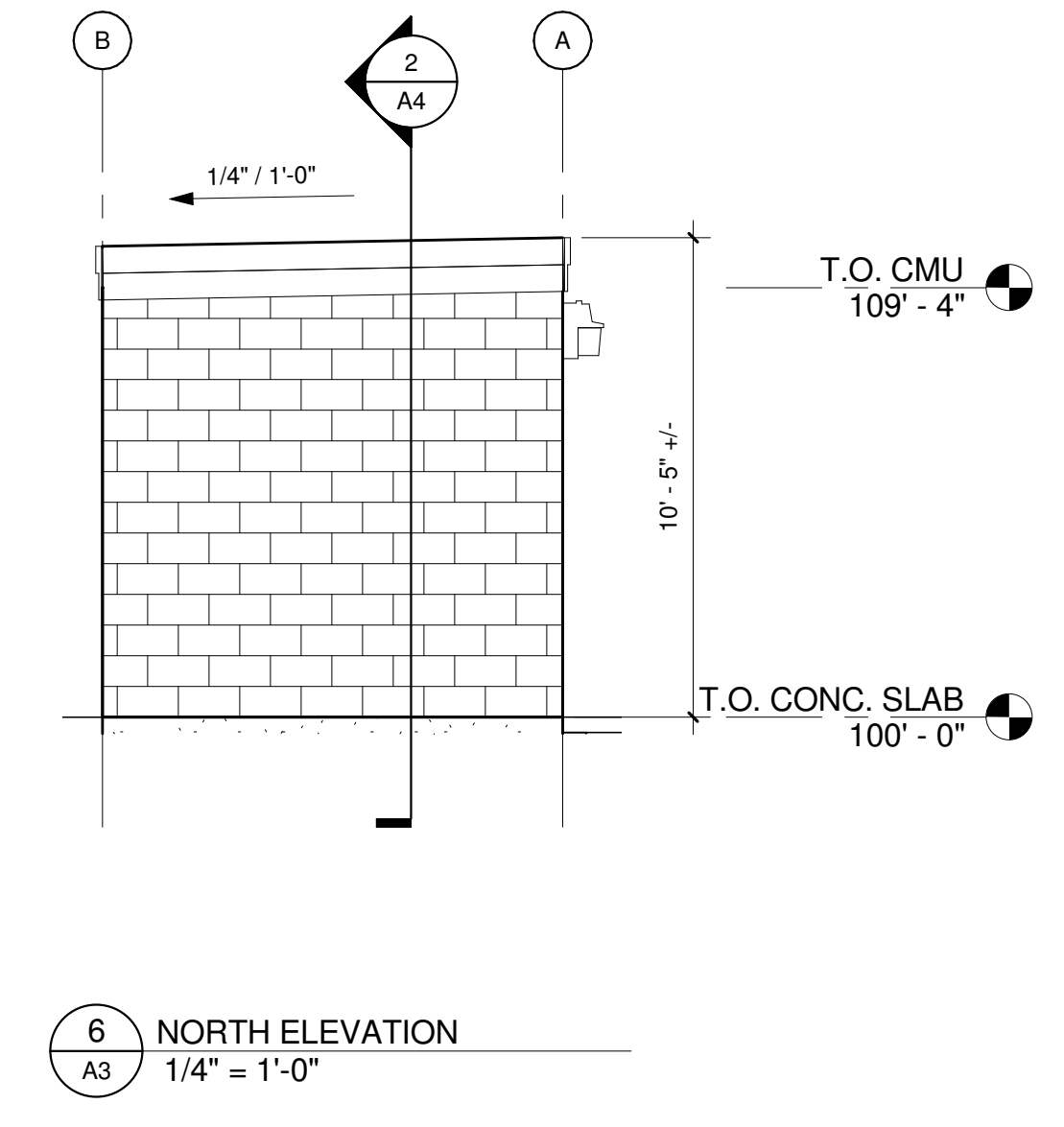
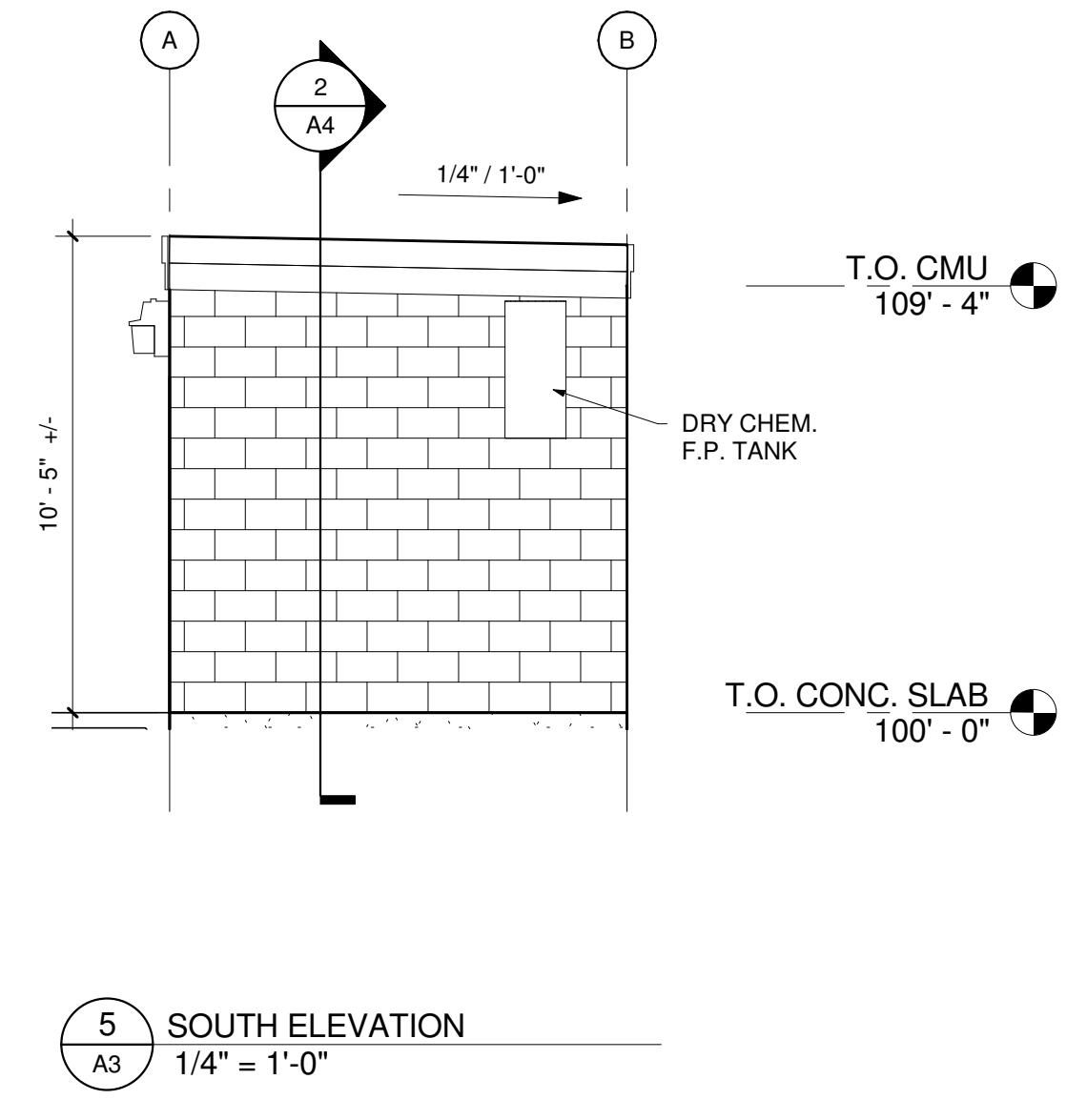
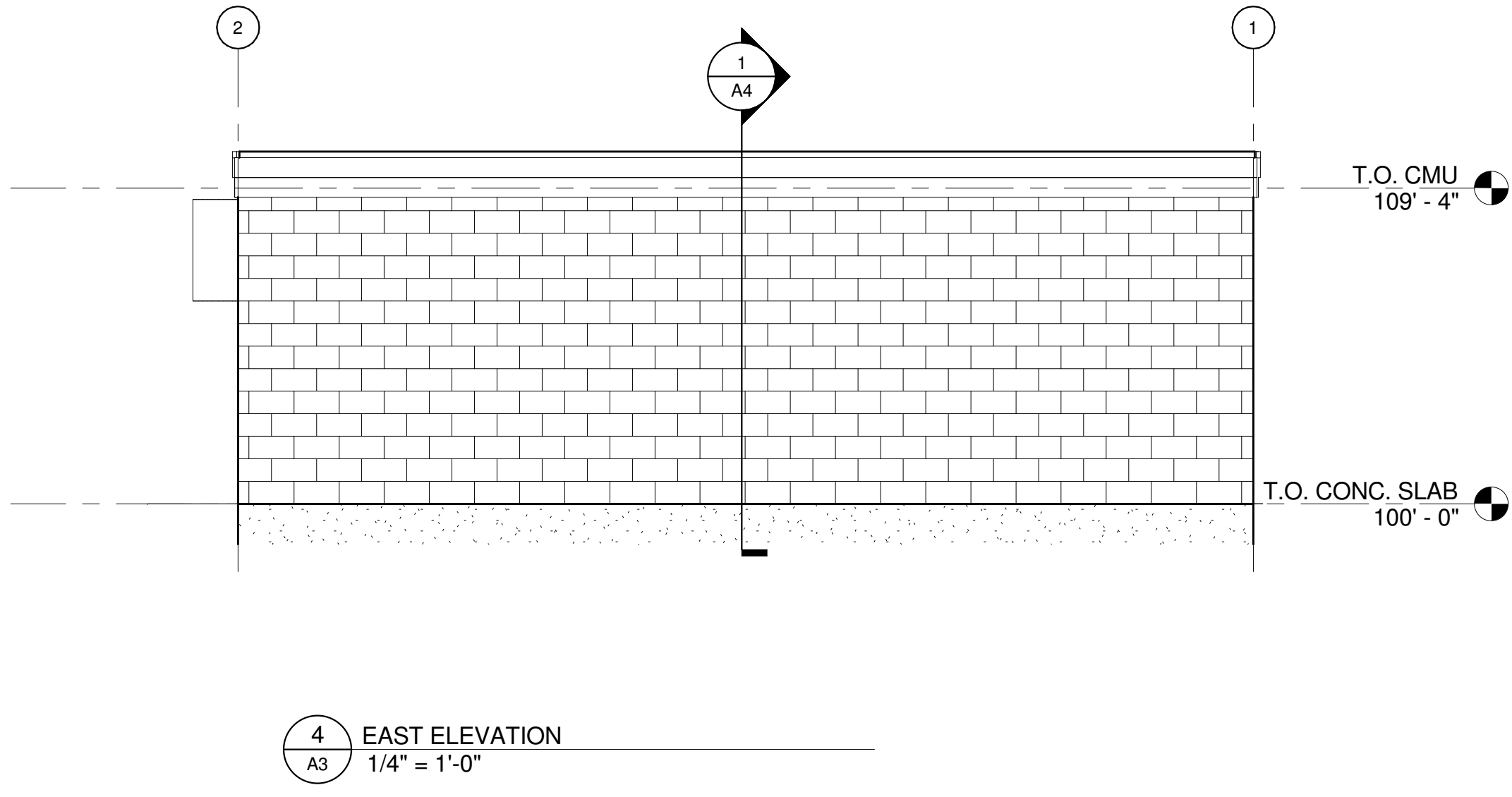
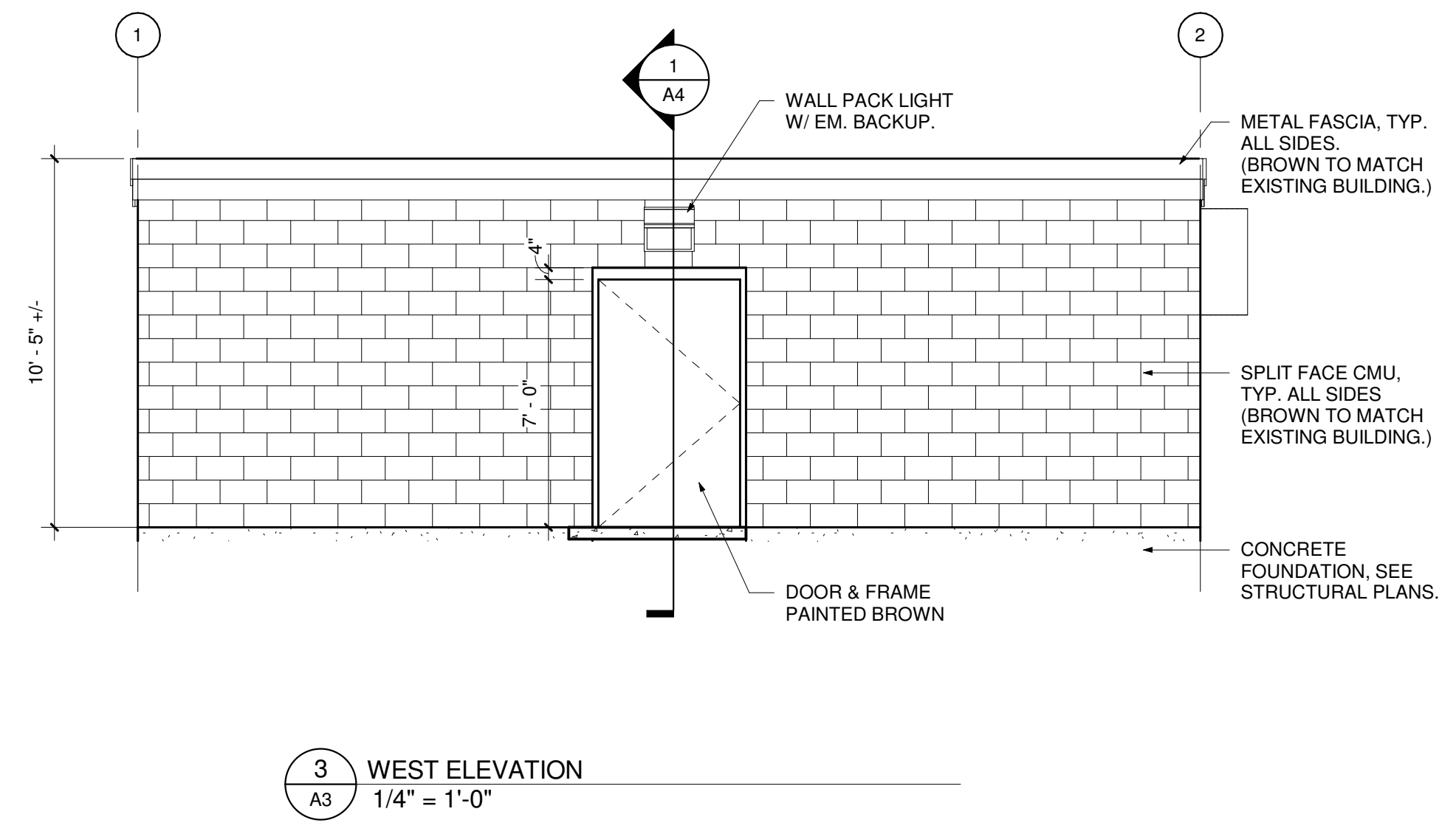
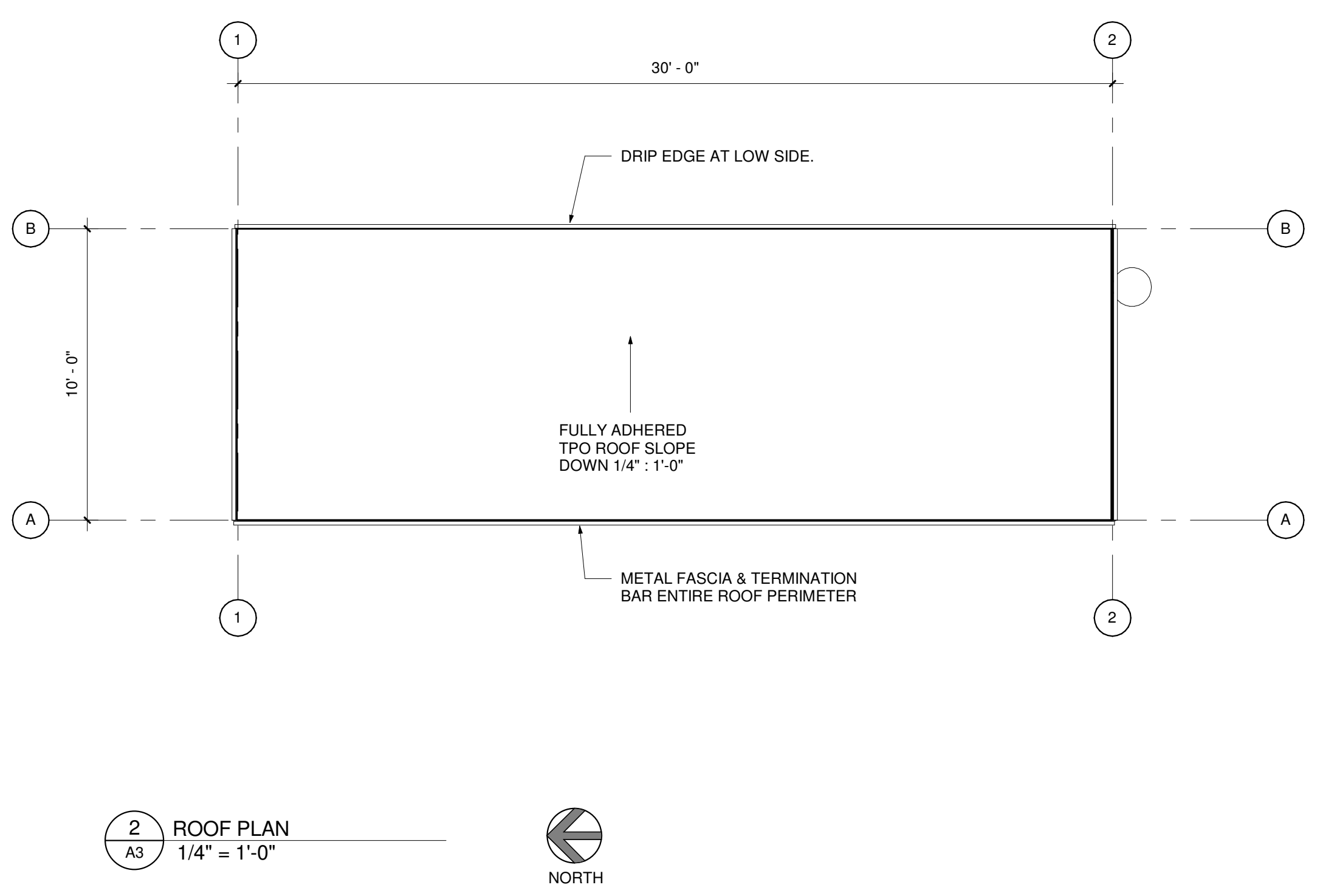
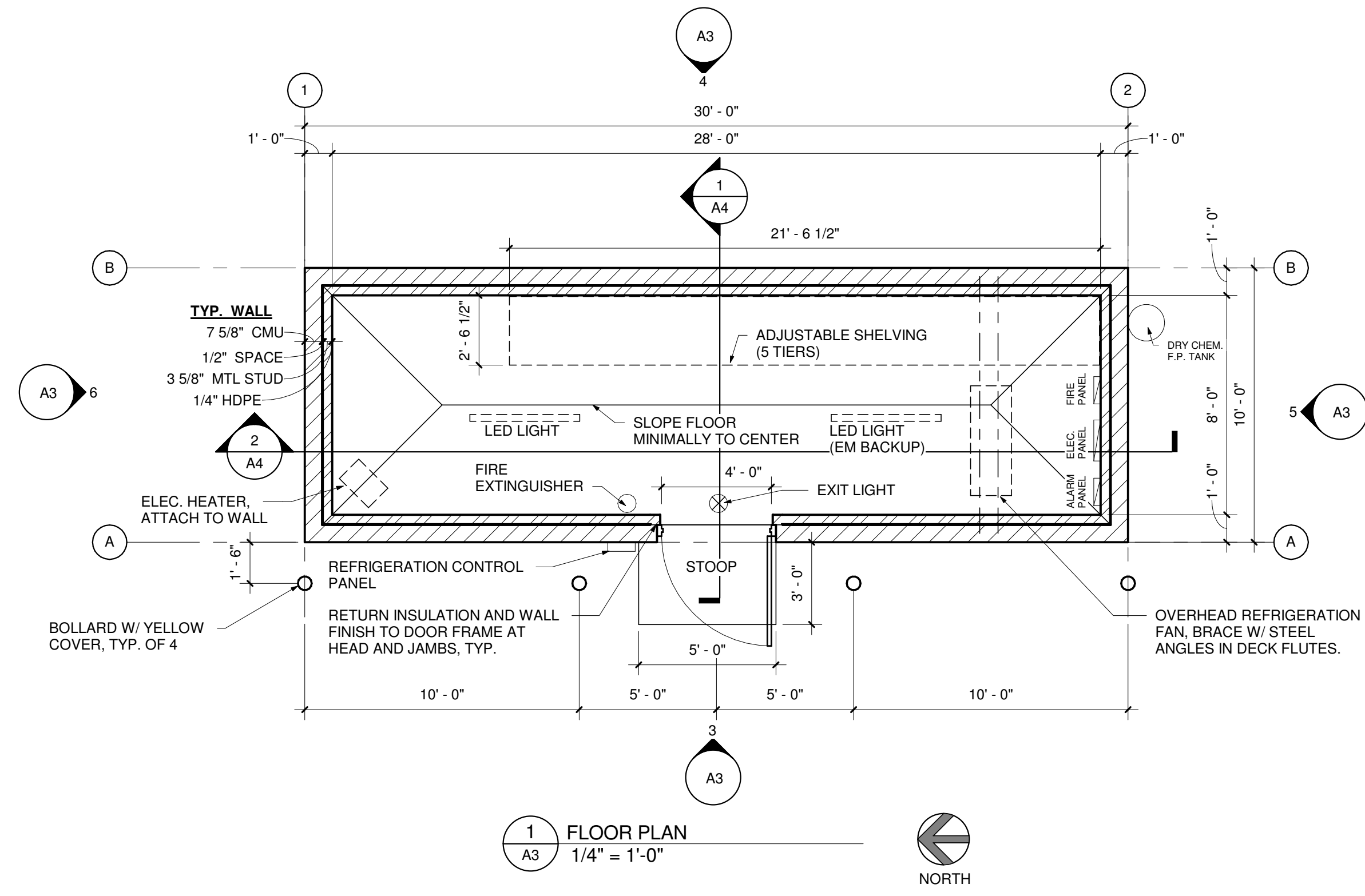

#	DATE	DESCRIPTION

DRAWN BY: KJO PROJECT # 18009
SHEET #

A3

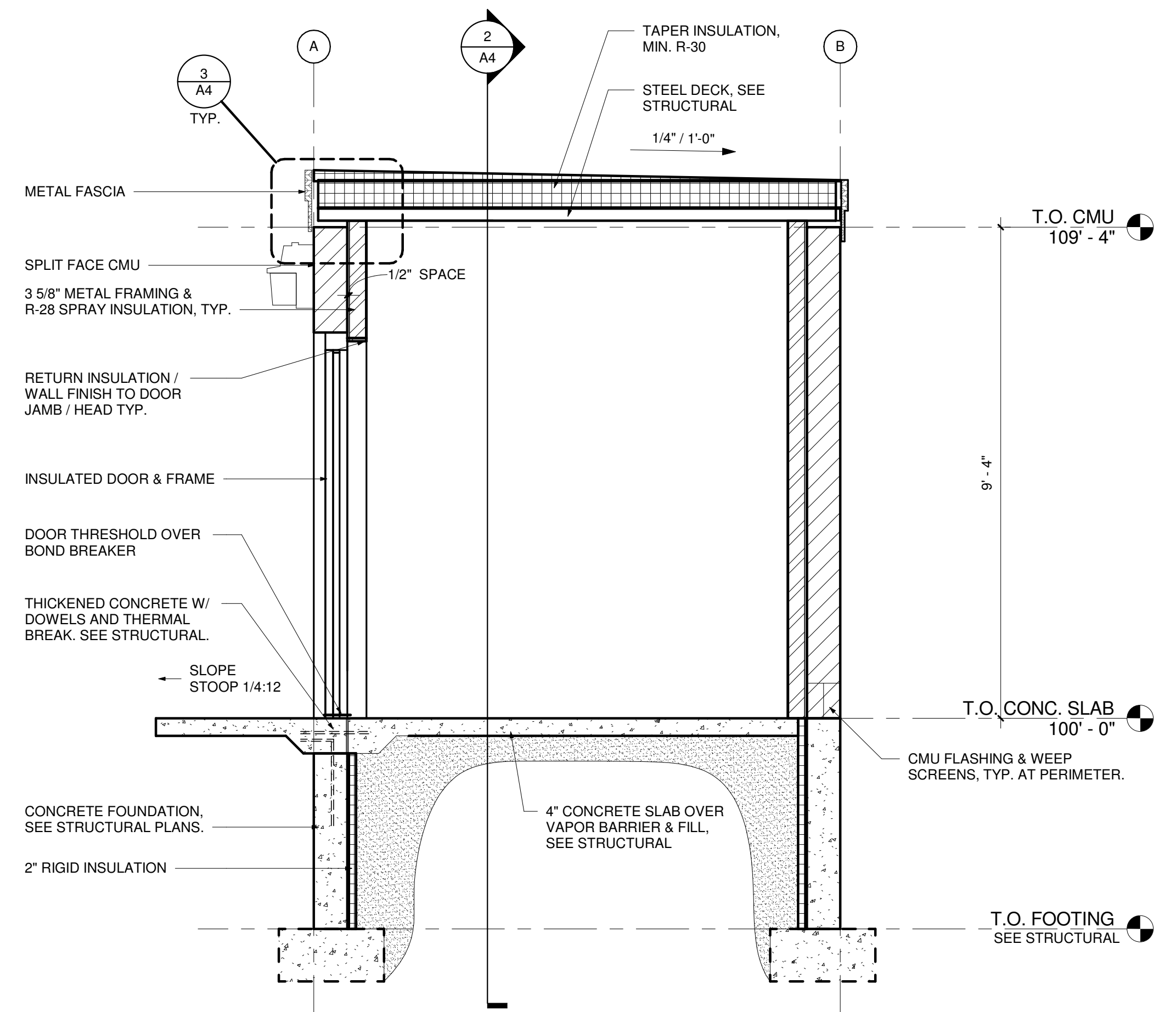

1 BUILDING SECTION 1
1/2" = 1'-0"

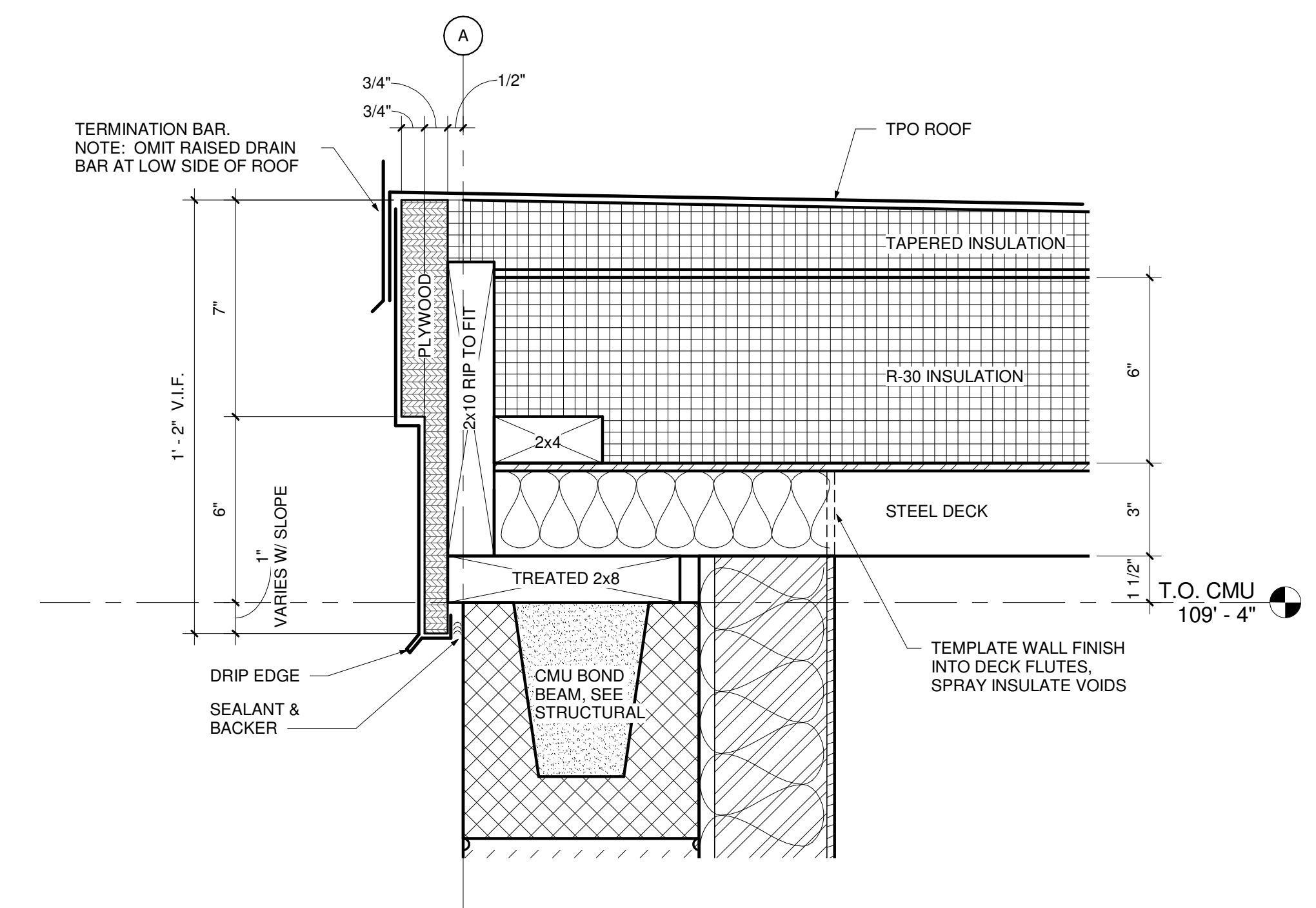

3 TYP. FASCIA / ROOF EDGE DETAIL
3" = 1'-0"

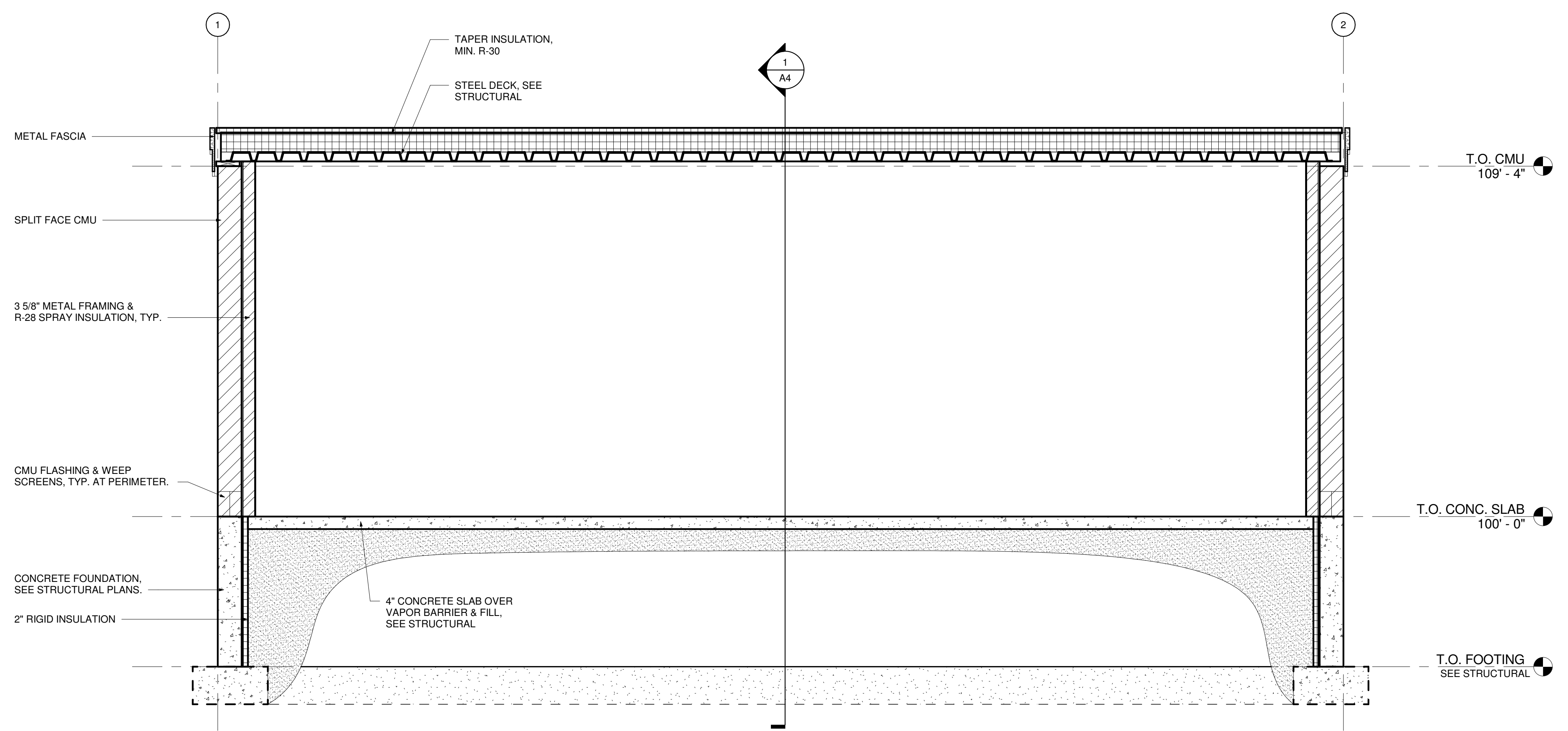

2 BUILDING SECTION 2
1/2" = 1'-0"

#	DATE	DESCRIPTION

DRAWN BY: KJO PROJECT # 18009
SHEET #

A4