

2 1/2-Bay Double Helix

Not to scale

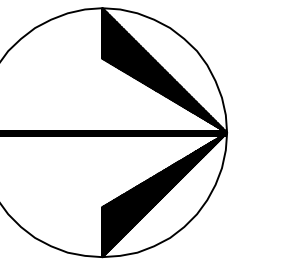

PROJECT
NORTH

PARKING SUMMARY		
LEVEL	STALLS 9' x 18'	AREA S.F.
Cross Over	11	5,992
Sixth Level	127	45,000
Fifth Level	124	45,000
Fourth Level	127	45,000
Third Level	124	45,000
Second Level	108	35,120
Ground Level	40	35,120
Total	661	256,232
388 SQUARE FEET PER STALL		

NOTES:

RETAIL = 9,880 square feet.

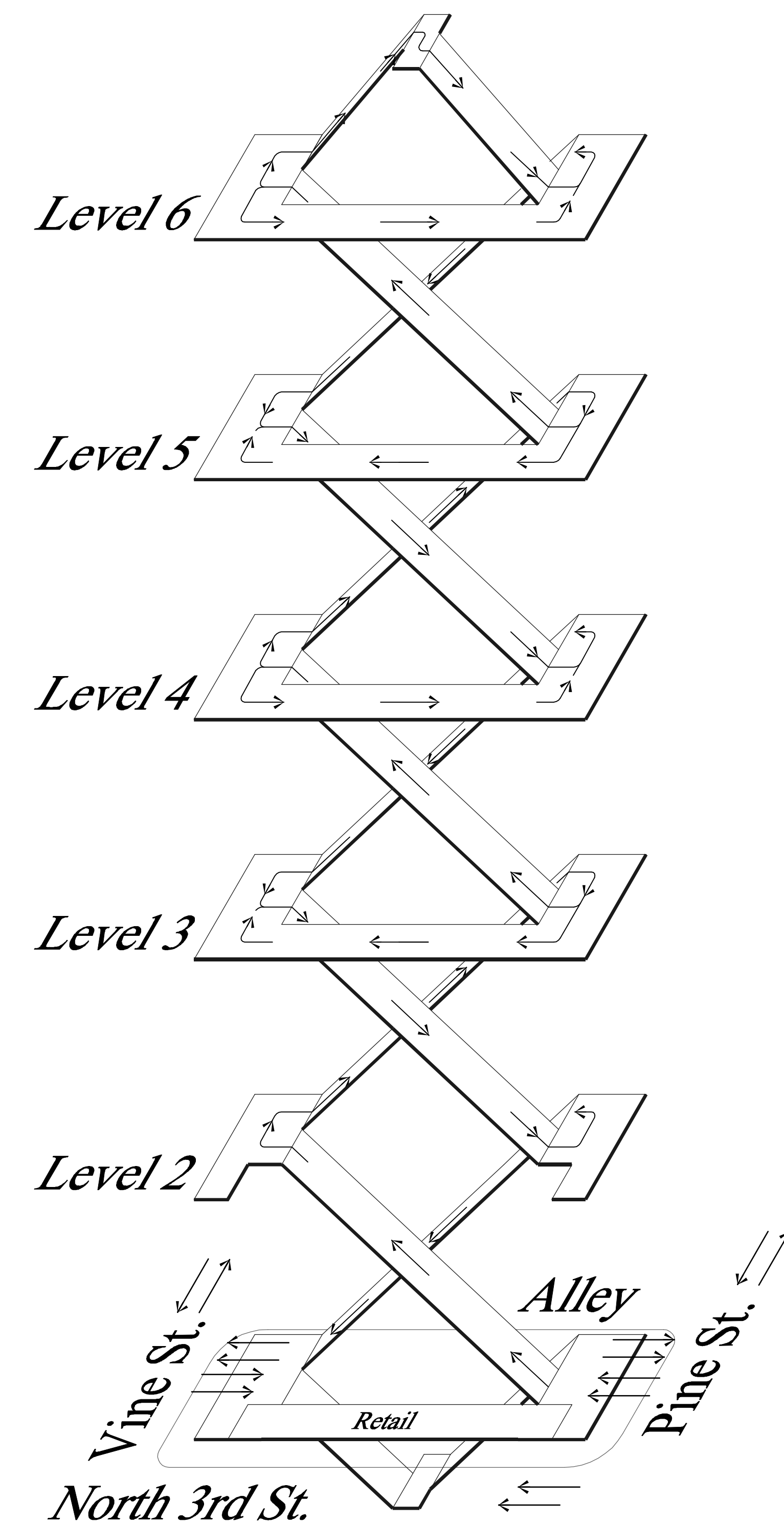

Isometric Diagram

Parking Summary and Isometric Diagrams

December 1, 2015

Third and Vine City Parking Garage

La Crosse, Wisconsin



2 1/2-Bay Double Helix

Not to scale

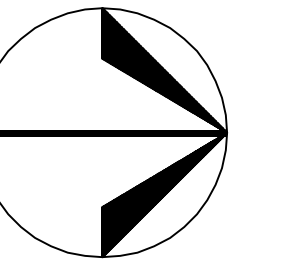

PROJECT
NORTH

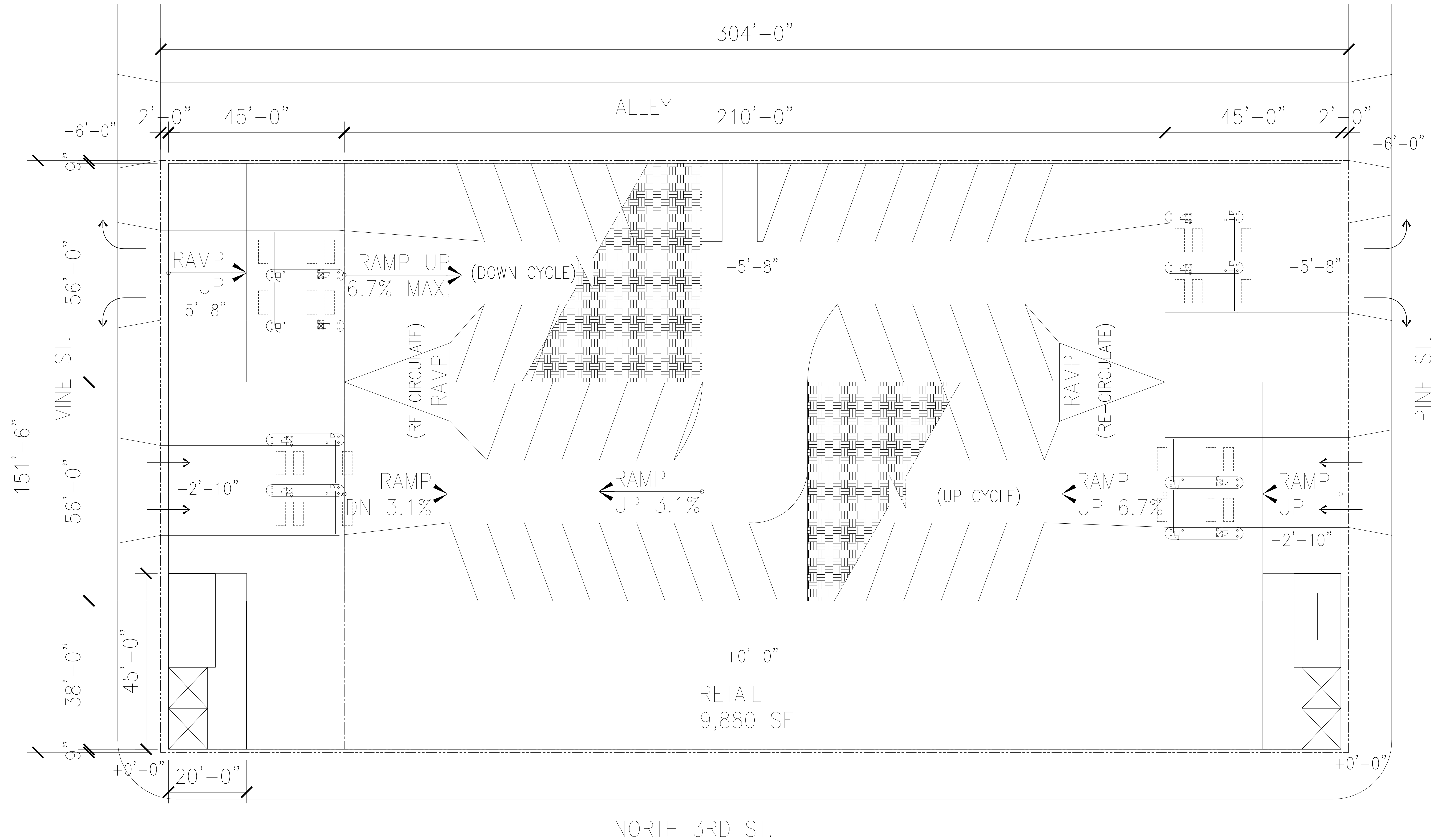

Ground Level Plan

December 1, 2015

Third and Vine City Parking Garage La Crosse, Wisconsin



2 1/2-Bay Double Helix

Not to scale

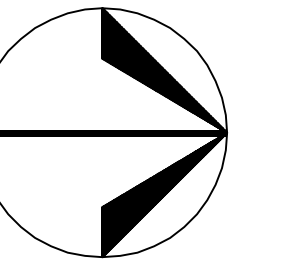

PROJECT
NORTH

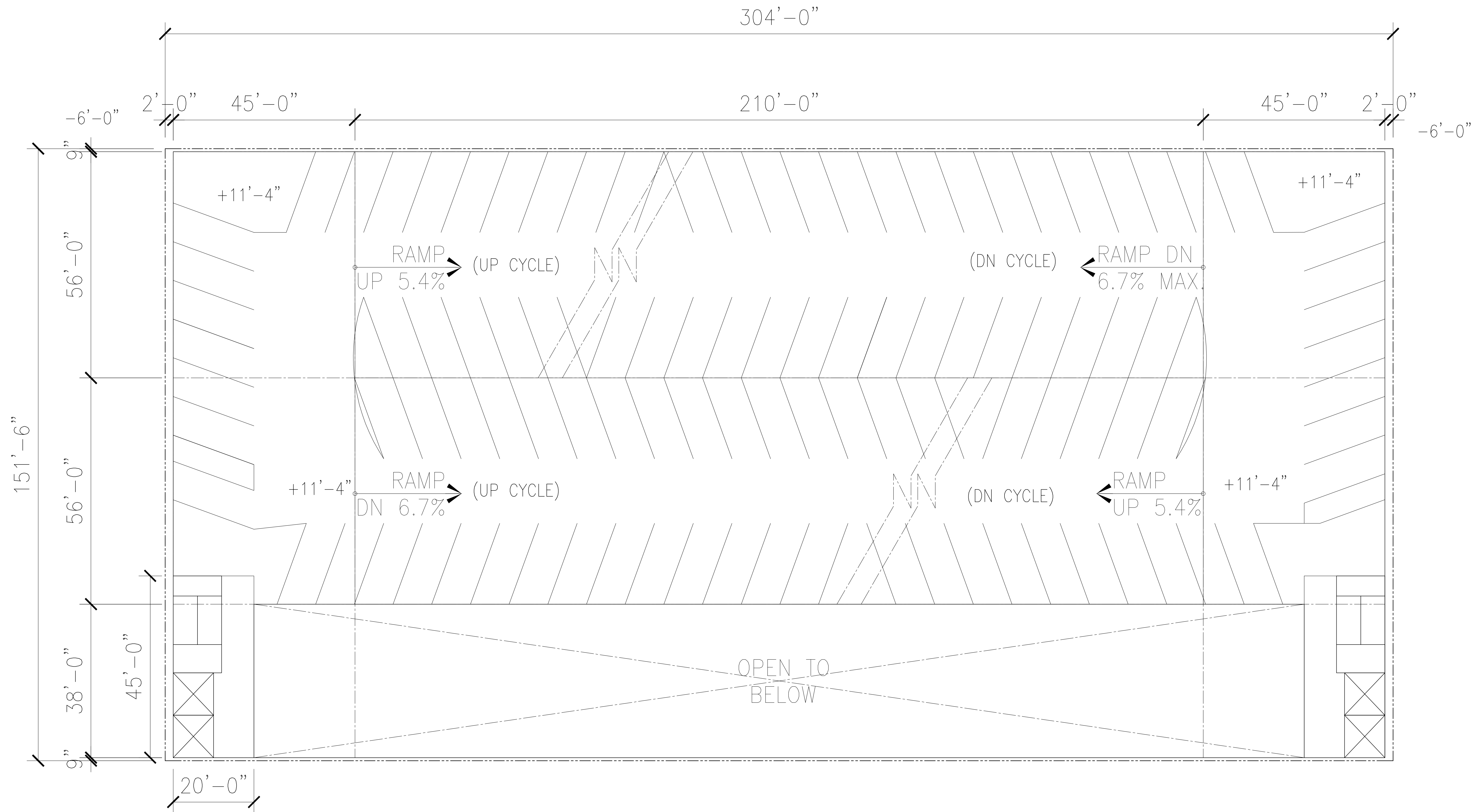

Second Level Plan

December 1, 2015

2 1/2-Bay Double Helix

Not to scale

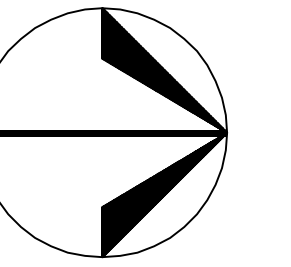

PROJECT
NORTH

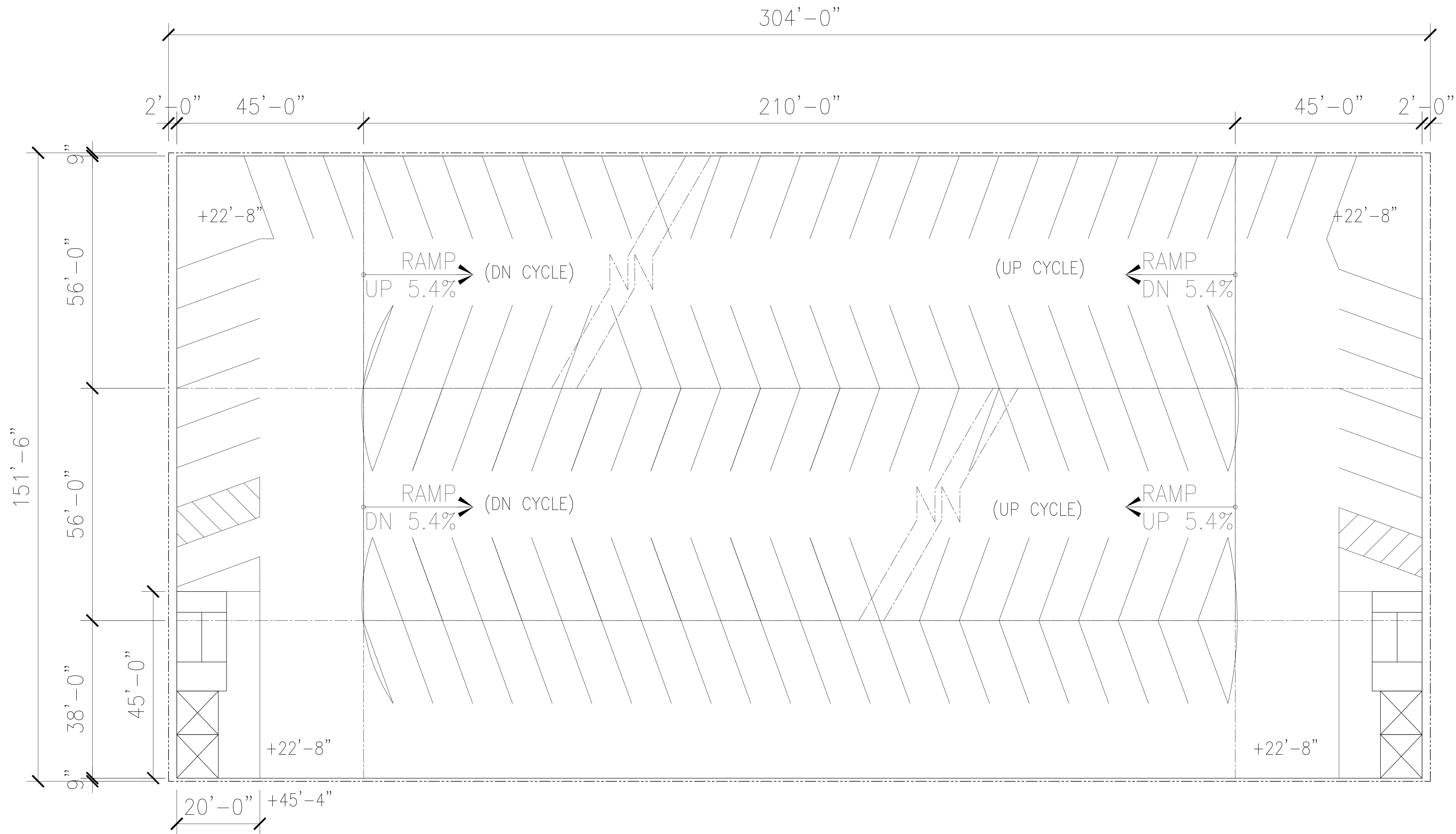

Third Level Plan (Fifth Level Similar)

December 1, 2015

Third and Vine City Parking Garage
La Crosse, Wisconsin

DESMAN
Design Management

2 1/2-Bay Double Helix

Not to scale

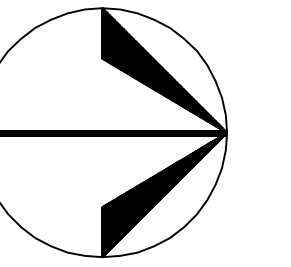

PROJECT
NORTH

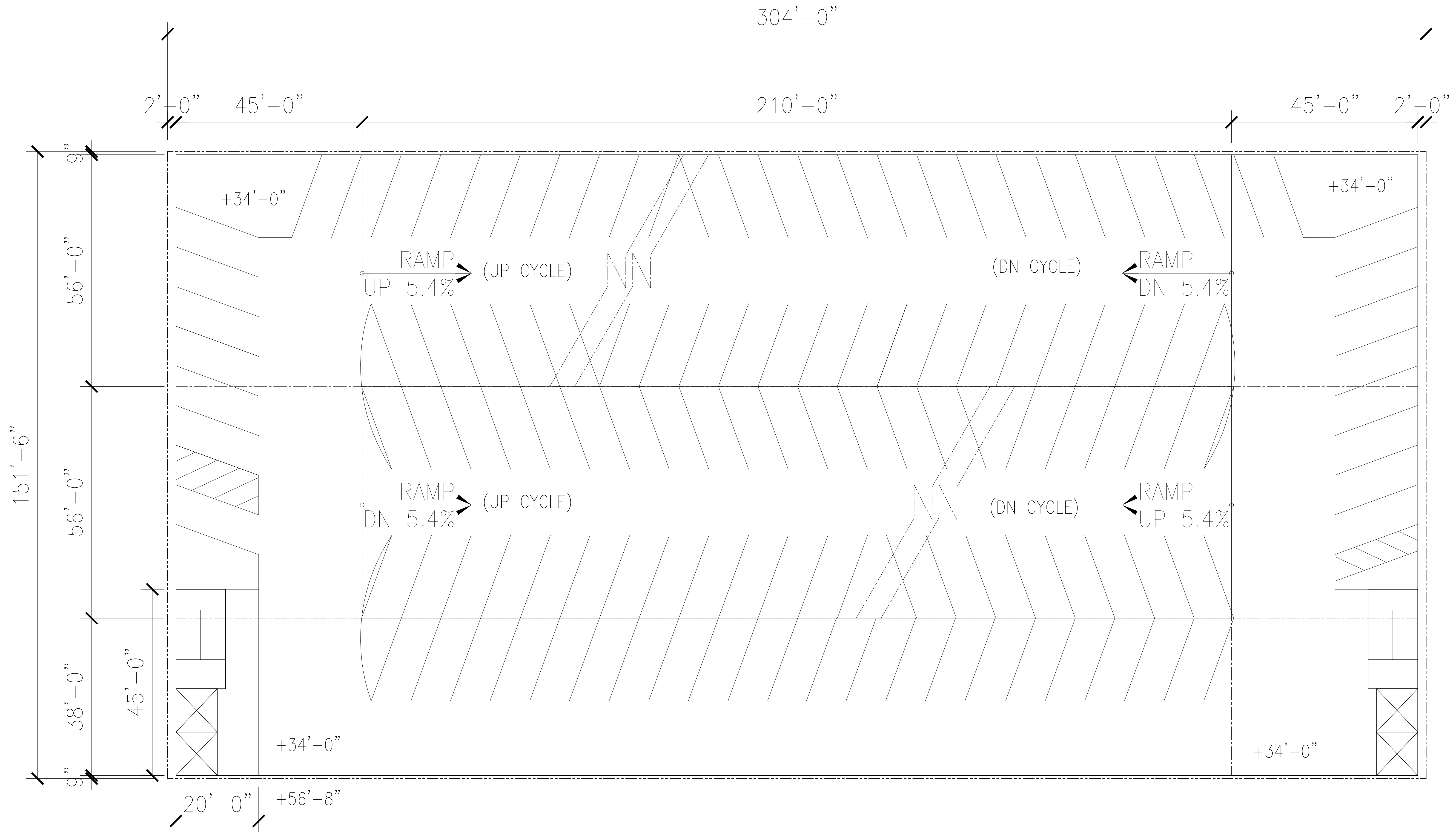

Fourth Level Plan (Sixth Level Similar)

December 1, 2015

Third and Vine City Parking Garage
La Crosse, Wisconsin

DESMAN
Design Management

2 1/2-Bay Double Helix

Not to scale

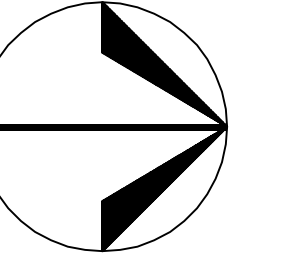

PROJECT
NORTH

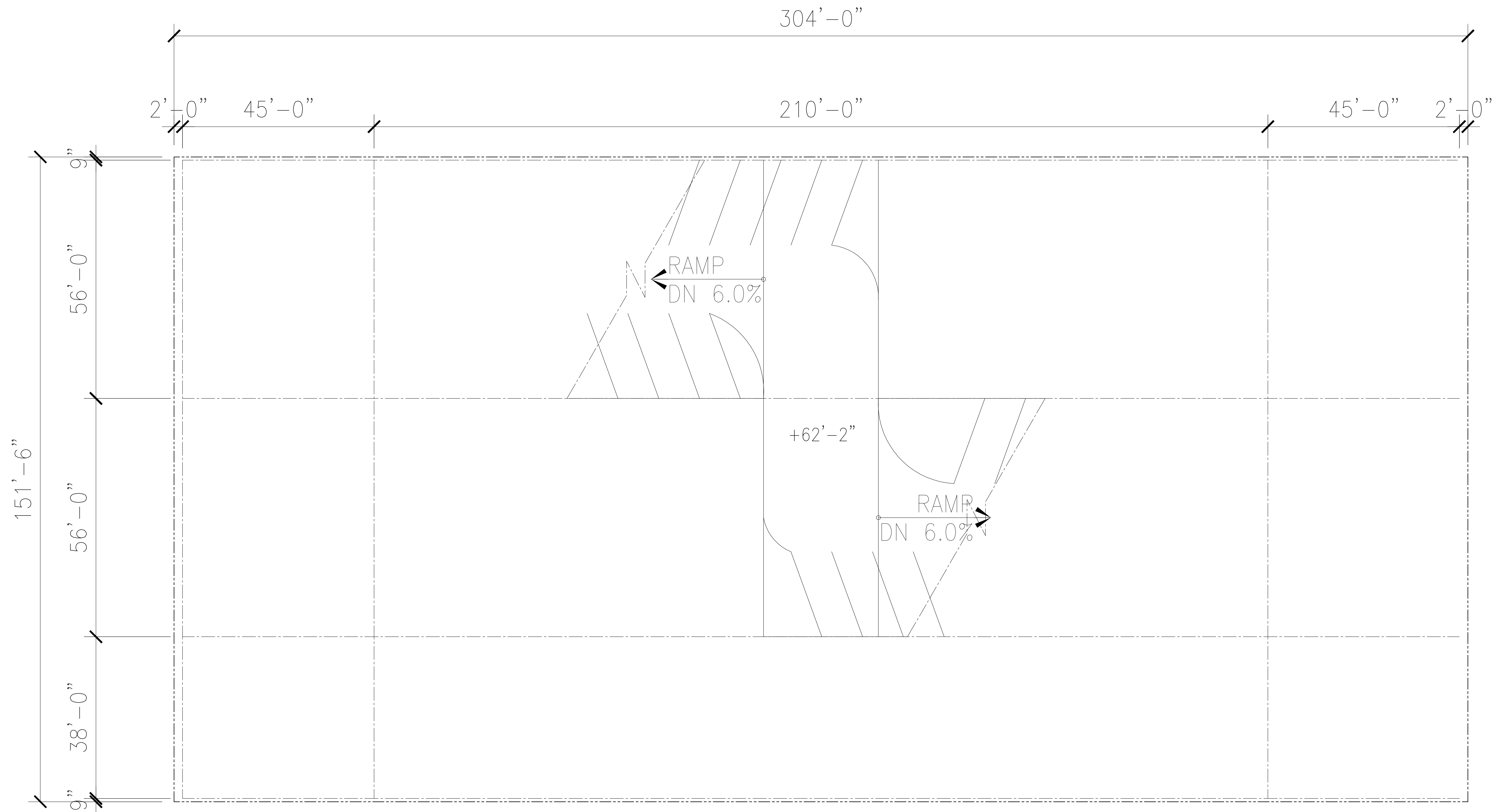

Seventh Level Plan

December 1, 2015