



CITY OF LA CROSSE COUNCIL LEGISLATION

Ord #

4006

CAPTION:

AN ORDINANCE to create Section 15.43 of the Code of Ordinances of the City of La Crosse entitled Traditional Neighborhood Development District Regulations.

REFERRAL ROUTE:

Intro. 11/8/01
City Plan
J&A
Public hearing 12/04/2001, 7:30 p.m.

ACTIONS AND DATES: (for Clerk's Office use only)

Received Second Reading
and passed

DEC 13 2001
BY COUNCIL

REQUESTED BY:

City Planner

INTRODUCED BY:

Mayor Medinger

REPORT OF COMMITTEE

To the Honorable Mayor and Common Council of the City of La Crosse:

Your Judiciary & Administrative Committee, having under consideration the annexed Ordinance to create Section 15.43 of the Code of Ordinances of the City of La Crosse entitled Traditional Neighborhood Development District Regulations, and said matter having been referred to the City Plan Commission, and the same having made and filed its report thereon, and due notice of hearing having been given, proof of publication which is attached hereto, and said hearing having been heard at the time and space specified in said notice, and all persons having had an opportunity to be heard for and against said zoning change, recommends the same be adopted.

Respectfully submitted,

Richard P. Becker, Chmn.
Charles Clemence
Phil Addis
Dave Goodin
Todd A. Olson
Robert H. Slaback

Received Second Reading
and passed

DEC 13 2001

BY COUNCIL

Typed: 12-5-01

Approved:

Lehrke, Teri

From: Lehrke, Teri
Sent: Wednesday, September 08, 2010 11:28 AM
To: 'Comp.Planning@wisconsin.gov'
Cc: Kirch, Larry
Attachments: ORD4006.doc

Pursuant to email from Peter Herreid dated September 7, 2010, and according to a state law enacted May 13, 2010, this is to advise you that the City of La Crosse adopted an ordinance regulating Traditional Neighborhood Development Districts on December 13, 2001. Attached is a conformed copy of the Ordinance.

Teri Lehrke, City Clerk
City of La Crosse
400 La Crosse St.
La Crosse, WI 54601
Population 51,900
(608) 789-7556
(608) 789-7552 (fax)
lehrket@cityoflacrosse.org

PRIVILEGED AND CONFIDENTIAL. *The information contained in this email message may be privileged, confidential and protected from disclosure. The email is intended solely for the intended recipient to whom it is addressed. Any review, retransmission, dissemination, distribution, copying, or other use is strictly prohibited. If you have received this email in error, please respond to the sender at lehrket@cityoflacrosse.org and delete the material from any computer and/or server.*

Lehrke, Teri

From: Kirch, Larry
Sent: Tuesday, September 07, 2010 4:57 PM
To: Lehrke, Teri
Subject: RE: Reporting Requirement for Traditional Neighborhood Development Ordinances

Very good. I think all it is, is a transmittal letter. After review of the statute, I don't think we were required to adopt one, only to report whether we have or not.

- (a) Not later than January 1, 2002, every city and village with a population of at least 12,500 shall, and every city and village with a population of less than 12,500 is encouraged to, enact an ordinance that is similar to the model **traditional neighborhood development** ordinance that is developed under sub. (2) (a) if the ordinance is approved under sub. (2) (b), although the ordinance is not required to be mapped.

From: Lehrke, Teri
Sent: Tuesday, September 07, 2010 4:52 PM
To: Kirch, Larry
Subject: RE: Reporting Requirement for Traditional Neighborhood Development Ordinances

If it's just a simple transmittal letter, I can do that. I wasn't sure if the form we adopted ours in was in accordance with the May 13, 2010 change in the law.

Teri Lehrke, City Clerk
City of La Crosse
400 La Crosse St.
La Crosse, WI 54601
Population 51,900
(608) 789-7556
(608) 789-7552 (fax)
lehrket@cityoflacrosse.org

PRIVILEGED AND CONFIDENTIAL. *The information contained in this email message may be privileged, confidential and protected from disclosure. The email is intended solely for the intended recipient to whom it is addressed. Any review, retransmission, dissemination, distribution, copying, or other use is strictly prohibited. If you have received this email in error, please respond to the sender at lehrket@cityoflacrosse.org and delete the material from any computer and/or server.*

From: Kirch, Larry
Sent: Tuesday, September 07, 2010 4:49 PM
To: Lehrke, Teri
Subject: RE: Reporting Requirement for Traditional Neighborhood Development Ordinances

Thanks Teri

I was not aware of this. I knew we had a deadline but I didn't know we had to send them a letter stating we had adopted it. We have one but all we did was adopt the state's model. We did it by Ordinance so it should be valid but we did not create our own.

Do you want me to send the correspondence? Can you give me a certified copy of the Ordinance adopting 15.43 and then I can send the letter?

Larry

From: Lehrke, Teri
Sent: Tuesday, September 07, 2010 4:11 PM
To: Kirch, Larry
Subject: FW: Reporting Requirement for Traditional Neighborhood Development Ordinances
Importance: High

FYI – not sure if you knew about this.

Teri Lehrke, City Clerk
City of La Crosse
400 La Crosse St.
La Crosse, WI 54601
Population 51,900
(608) 789-7556
(608) 789-7552 (fax)
lehrket@cityoflacrosse.org

PRIVILEGED AND CONFIDENTIAL. The information contained in this email message may be privileged, confidential and protected from disclosure. The email is intended solely for the intended recipient to whom it is addressed. Any review, retransmission, dissemination, distribution, copying, or other use is strictly prohibited. If you have received this email in error, please respond to the sender at lehrket@cityoflacrosse.org and delete the material from any computer and/or server.

From: Herreid, Peter E - DOA [<mailto:Peter.Herreid@Wisconsin.gov>]
Sent: Tuesday, September 07, 2010 3:51 PM
To: LALME@CI.STOUGHTON.WI.US
Cc: WULFJ@CI.JANESVILLE.WI.US; DUDASJ@KAUKAUNA-WI.ORG; AMIKEH@KENOSHA.ORG; Lehrke, Teri; CLERK@CITYOFMADISON.COM; JHUDON@MANITOWOC.ORG; DEBBIEH@CI.MARSHFIELD.WI.US; DGALEAZZ@CI.MENASHA.WI.US; JKADINGER@MENOMONIE-WI.GOV; LSZYMBORSKI@CI.MEQUON.WI.US; TAMBLE@CI.MIDDLETON.WI.US; JMOYER@CI.MUSKEGO.WI.US; PSTURN@CI.NEENAH.WI.US; MGAUGER@NEWBERLIN.ORG; PBAUER@OAKCREEKWI.ORG; DCOENEN@WPPISYS.ORG; CBURMASTER@CITYOFONALASKA.COM; JANICE.JOHNSON-MARTIN@CITYOFRACINE.GOV; srichards@ci.sheboygan.wi.us; LISOWSKI@CI.SOUTH-MILWAUKEE.WI.US; JMoe@STEVENSPOINT.COM
Subject: Reporting Requirement for Traditional Neighborhood Development Ordinances

DATE: September 7, 2010

TO: Cities and Villages With a Population of At Least 12,500

FROM: Peter Herreid, Grant Administrator
Comprehensive Planning Grant Program

SUBJECT: Statutory Requirement for Traditional Neighborhood Development Ordinance

A “traditional neighborhood development” means a compact, mixed-use neighborhood where residential, commercial and civic buildings are within close proximity to each other. According to s. 66.1027(3)(a), Wis. Stats., every city and village with a population of at least 12,500 shall enact an ordinance that is similar to the model traditional neighborhood development ordinance available on a University of Wisconsin webpage at the following location <http://urpl.wisc.edu/people/ohm/tndord.pdf>.

According to a state law enacted May 13, 2010, **not later than January 1, 2011, every city, and village with a population of at least 12,500 shall report to the department of administration whether it has enacted an ordinance** under par. (a) (66.1027(3)(c), Wis. Stats.). Submittal of a copy of the ordinance is not required, but communities are welcome to submit copies of their ordinances.

Cities and villages can report to the Wisconsin Department of Administration at any of the following:

Tel.: 608.267.3369

Email: Comp.Planning@wisconsin.gov

Fax: 608-267-6917

Mailing Address:

Comprehensive Planning

WI DOA

101 E. Wilson St., 9th Floor

Madison, WI

Peter Herreid

Grant Administrator

608.267.3369

Comprehensive Planning Grant Program

Wisconsin Land Information Program

AFFIDAVIT OF PUBLICATION

STATE OF WISCONSIN, }
La Crosse County. } ss.

Deb Bailey, being duly sworn, says that she is the principal clerk of THE LA CROSSE TRIBUNE, a public daily newspaper of general circulation, printed and published in the City of La Crosse, in the county and State aforesaid, and that the notice of which the annexed is printed copy taken from the paper in which the same was published, was inserted and published in the said newspaper on the 22 day of Dec, 2001

and thereafter on the following dates, to wit:

being at least once in each week for _____
successive weeks.

Deb Bailey

fore me this 22 day of Dec, A.D. 2001

Sue Chenier

Notary Public, La Crosse County, Wisconsin

12/22 2370365
ORDINANCE NO. 4006
AN ORDINANCE to create Section 15.43 of the Code of Ordinances of the City of La Crosse entitled Traditional Neighborhood Development District Regulations.
THE COMMON COUNCIL of the City of La Crosse do ordain as follows:
SECTION I: Subsection 15.43 of the Code of Ordinances of the City of La Crosse is hereby created to read as follows:
15.43: PLANNED DEVELOPMENT DISTRICT: TRADITIONAL NEIGHBORHOOD DEVELOPMENT.
(A) Proposed developments contemplated by an applicant to include design features described as "traditional neighborhood development" in Wisconsin Statutes sec. 66.1027(1)(c) (1999-2000 Statutes) may be considered for approval at locations determined appropriate by the City under this section, including appropriate conditions.
(B) A document identified as "A MODEL ORDINANCE FOR TRADITIONAL NEIGHBORHOOD DEVELOPMENT," dated December, 2000, published by the University Extension pursuant to Wisconsin Statutes sec. 66.1027(2), shall serve as a non-exclusive guidebook to assist in further defining the various aspects of this form of urban design, along with such other sources of guidance the Plan Commission and local governing body may choose to consult.
SECTION II: This ordinance shall take effect and be in force from and after its passage and publication.
s/John D. Medinger, Mayor
s/Teri Lehrke, City Clerk

My Commission expires 12/22
ORDINANCE NO. 4006

AN ORDINANCE to create Section 15.43 of the Code of Ordinances of the City of La Crosse entitled Traditional Neighborhood Development District Regulations.
THE COMMON COUNCIL of the City of La Crosse do ordain as follows:
SECTION I: Subsection 15.43 of the Code of Ordinances of the City of La Crosse is hereby created to read as follows:
15.43: PLANNED DEVELOPMENT DISTRICT: TRADITIONAL NEIGHBORHOOD DEVELOPMENT.
(A) Proposed developments contemplated by an applicant to include design features described as "traditional neighborhood development" in Wisconsin Statutes sec. 66.1027(1)(c) (1999-2000 Statutes) may be considered for approval at locations determined appropriate by the City under this section, including appropriate conditions.
(B) A document identified as "A MODEL ORDINANCE FOR TRADITIONAL NEIGHBORHOOD DEVELOPMENT," dated December, 2000, published by the University Extension pursuant to Wisconsin Statutes sec. 66.1027(2), shall serve as a non-exclusive guidebook to assist in further defining the various aspects of this form of urban design, along with such other sources of guidance the Plan Commission and local governing body may choose to consult.
SECTION II: This ordinance shall take effect and be in force from and after its passage and publication.
s/John D. Medinger, Mayor

12/21/2003

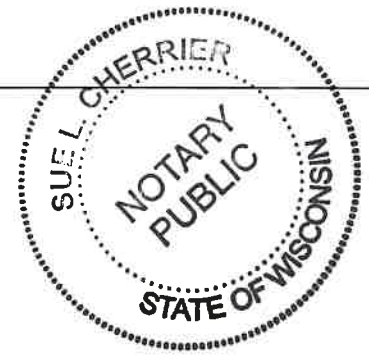



COMMON COUNCIL CITY OF LA CROSSE

The following Committee(s) considered the attached matter and make(s) the following recommendation to the Common Council:

Subject: An Ordinance to create Section 15.43 of the Code of Ordinances of the City of La Crosse entitled Traditional Neighborhood Development District Regulations.

JUDICIARY & ADMINISTRATION COMMITTEE

MOTION: *approve CPC report*

VOTE:	ABSENT	FOR	AGAINST
BECKER		X	
CLEMENCE		X	
GOODIN		X	
OLSON		X	
SLABACK		X	
ADDIS		X	
Total		6	0

DATA ON PUBLIC HEARINGS
Persons appeared in favor:
NAME ADDRESS

Persons appeared against:
NAME ADDRESS

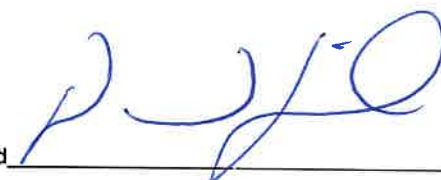
Date **DEC 04 2001** Signed 

HIGHWAYS, PROPERTIES & UTILITIES COMMITTEE

MOTION:

VOTE:	ABSENT	FOR	AGAINST
GILLES			
HARDEN			
MANEY			
PETERS			
SATORY			
SOLVERSON			
Total			

DATA ON PUBLIC HEARINGS
Persons appeared in favor:
NAME ADDRESS

Persons appeared against:
NAME ADDRESS

Date _____ Signed _____

FINANCE & PERSONNEL COMMITTEE

MOTION:

VOTE:	ABSENT	FOR	AGAINST
EVERY			
FARMER			
JOHNSRUD			
LEDVINA			
MEYER			
MORRISON			
Total			

DATA ON PUBLIC HEARINGS
Persons appeared in favor:
NAME ADDRESS

Persons appeared against:
NAME ADDRESS

Date _____ Signed _____

Law Update

BY RICHARD LEHMANN

WAPA Legal Counsel
Boardman Law Firm
Madison, WI
rlehmann@boardmanlawfirm.com

For more Law Updates and more detail on the items printed here, please refer to the WAPA web page:
www.uwm.edu/Org/wapa/law/law.htm

January 1, 2002 Deadline Approaches For Adoption Of A Traditional Neighborhood Development Ordinance

A component of the 1999 Legislative adoption of Comprehensive Planning statute required all incorporated municipalities of 12,500 or more to adopt an ordinance allowing a "traditional neighborhood development." University Extension was directed to develop a "model ordinance." The Extension model has been published. Extension's version of a zoning district for this form of development is 38 pages long, with illustrations. The Boardman Law Firm Land Use Law Practice Group is recommending that municipalities consider something simpler, such as the draft below.

ORDINANCE NO. _____

CREATING ZONING ORDINANCE SECTION
_____: PLANNED DEVELOPMENT DISTRICT:
TRADITIONAL NEIGHBORHOOD DEVELOPMENT

PLANNED DEVELOPMENT DISTRICT:
TRADITIONAL NEIGHBORHOOD DEVELOPMENT

Proposed developments contemplated by an applicant to include design features described as "traditional neighborhood development" in Wisconsin Statutes sec. 66.1027(1)(c) (1999-2000 Statutes) may be considered for approval at locations determined appropriate by the City/Village under this section, including appropriate conditions.

A document identified as "A MODEL ORDINANCE FOR TRADITIONAL NEIGHBORHOOD DEVELOPMENT," dated December, 2000, published by the University of Wisconsin Extension pursuant to Wisconsin Statutes sec. 66.1027(2), shall serve as a non-exclusive guidebook to assist in further defining the various aspects of this form of urban design, along with such other sources of guidance the Plan Commission and local governing body may choose to consult.

Consistency Between Planning and Zoning

Starting in 2010, the rule of law in Wisconsin will be that all zoning and other land use actions must be consistent with a comprehensive plan. This rule is on the law books, with the delayed, 2010 effective date (Wisconsin Statutes sec. 66.1001(3)). Enforcement, as the law is currently written, will be by the courts. There is no precedent in Wisconsin, so the handling of consistency issues by courts in other states is of great interest.

On September 26, 2001 the District 4 Florida Court of Appeals decided a case in which a County Commission had issued zoning approval for a group of two story, 8-unit apartment buildings located next to a low density single family neighborhood. The County's comprehensive plan designated the apartment area for medium density multiple family residential at up to 8 units per acre. The zoning approval was for roughly 6.5 units per acre. There was, however, no transitioning of the density and the comprehensive plan called for the multiple family tract to keep its edge nearest the single family development in single family development as a means of transitioning.

A single family residential neighbor sued on grounds of lack of consistency between the approval and the plan. The neighbor's suit initially lost at the trial court after a certiorari-type review. At this point, the developer took out permits for 5 of the buildings and started construction. The neighbor sent a letter saying the construction was at the developer's risk and that the neighbor intended to seek a court order of demolition if the trial court's ruling were to be reversed.

An appeal court sent the case back for a second look, under a de novo review standard. This time the trial court struck down the zoning approval under the plan consistency test. The trial court then ordered the five constructed and partially constructed buildings removed. Three of the buildings had been occupied by that point.

The developer appealed. This time, the appeals court forbade more construction and more leasing, but allowed the existing leases to expire.

The second appeal resulted in the trial court's finding of inconsistency and the trial court's drastic remedy being upheld.

As to inconsistency, the appeals court found that the plan was specific as to the density transition. The municipality could not substitute landscaping for the density transition buffer, nor could the buffer be ignored.

As to remedy, the court notes that Florida law mandates each local government to have a comprehensive plan. It mandates all zoning to be consistent with those plans. It authorizes suits by aggrieved property owners to enforce the mandates. It allows those suits to ask for injunctive relief. These laws mean that consistency is a public policy command by the legislature, a command that should not be able to be waived by the courts. The courts are not allowed their usual power to "balance the equities" when these mandates are violated.

AFFIDAVIT OF PUBLICATION

STATE OF WISCONSIN, }
La Crosse County. } ss.

Deb Bailey, being duly sworn, says that she is the principal clerk of THE LA CROSSE TRIBUNE, a public daily newspaper of general circulation, printed and published in the City of La Crosse, in the county and State aforesaid, and that the notice of which the annexed is printed copy taken from the paper in which the same was published, was inserted and published in the said newspaper

on the 13 day of Nov, 2001

and thereafter on the following dates, to wit:

11-20-01

being at least once in each week for 2 successive weeks.

Deb Bailey

before me this 18 day of Nov, A.D. 2001

Kelly Ostie

Notary Public, La Crosse County, Wisconsin

October 20, 2002

11/13,20 2326110
NOTICE OF HEARING ON AMENDMENT TO ZONING RESTRICTION
TO WHOM IT MAY CONCERN:
Notice is hereby given that the Common Council of the City of La Crosse by its Judiciary and Administration Committee will hold a public hearing upon the proposed change in the zoning ordinance hereinafter set forth. **Such public hearing will be held at 7:30 p.m. on Tuesday, December 4, 2001** in the Council Chambers in the City Hall in the City of La Crosse, La Crosse County, Wisconsin.
You are further notified that the **City Plan Commission** of the City of La Crosse will meet to consider such ordinance on **Monday, December 3, 2001 at 4:00 p.m.** in the 5th Floor Conference Room in City Hall, in the City of La Crosse, La Crosse County, Wisconsin.
Said proposed ordinance will also go before the **Committee of the Whole** on **Tuesday, December 11, 2001 at 7:30 p.m.** and final action will be determined by the **Common Council on Thursday, December 13, 2001 at 7:30 p.m.**, both in the Council Chambers in the City Hall in the City of La Crosse, La Crosse County, Wisconsin.
You are further notified that any person interested may be heard for or against such proposed change, and may appear in person, by attorney or may file a formal objection, which objection forms are available in the Office of the City Clerk.
Such proposed change set forth in the ordinance now pending before the Common Council of the City of La Crosse is as follows:
An Ordinance to create Section 15.43 of the Code of Ordinances of the City of La Crosse entitled Traditional Neighborhood Development District Regulations.
Dated this 9th day of November, 2001.
Teri Lehrke, City Clerk
City of La Crosse

AMENDMENT TO ZONING RESTRICTION

TO WHOM IT MAY CONCERN:
Notice is hereby given that the Common Council of the City of La Crosse by its Judiciary and Administration Committee will hold a public hearing upon the proposed change in the zoning ordinance hereinafter set forth. **Such public hearing will be held at 7:30 p.m. on Tuesday, December 4, 2001** in the Council Chambers in the City Hall in the City of La Crosse, La Crosse County, Wisconsin.
You are further notified that the **City Plan Commission** of the City of La Crosse will meet to consider such ordinance on **Monday, December 3, 2001 at 4:00 p.m.** in the 5th Floor Conference Room in City Hall, in the City of La Crosse, La Crosse County, Wisconsin.
Said proposed ordinance will also go before the **Committee of the Whole** on **Tuesday, December 11, 2001 at 7:30 p.m.** and final action will be determined by the **Common Council on Thursday, December 13, 2001 at 7:30 p.m.**, both in the Council Chambers in the City Hall in the City of La Crosse, La Crosse County, Wisconsin.
You are further notified that any person interested may be heard for or against such proposed change, and may appear in person, by attorney or may file a formal objection, which objection forms are available in the Office of the City Clerk.
Such proposed change set forth in the ordinance now pending before the Common Council of the City of La

**NOTICE OF HEARING ON
AMENDMENT TO ZONING RESTRICTION**

TO WHOM IT MAY CONCERN:

Notice is hereby given that the Common Council of the City of La Crosse by its Judiciary and Administration Committee will hold a public hearing upon the proposed change in the zoning ordinance hereinafter set forth. **Such public hearing will be held at 7:30 p.m. on Tuesday, December 4, 2001** in the Council Chambers in the City Hall in the City of La Crosse, La Crosse County, Wisconsin.

You are further notified that the **City Plan Commission** of the City of La Crosse will meet to consider such ordinance on **Monday, December 3, 2001 at 4:00 p.m.** in the 5th Floor Conference Room in City Hall, in the City of La Crosse, La Crosse County, Wisconsin.

Said proposed ordinance will also go before the **Committee of the Whole** on **Tuesday, December 11, 2001 at 7:30 p.m.** and final action will be determined by the **Common Council** on **Thursday, December 13, 2001 at 7:30 p.m.**, both in the Council Chambers in the City Hall in the City of La Crosse, La Crosse County, Wisconsin.

You are further notified that any person interested may be heard for or against such proposed change, and may appear in person, by attorney or may file a formal objection, which objection forms are available in the Office of the City Clerk.

Such proposed change set forth in the ordinance now pending before the Common Council of the City of La Crosse is as follows:

An Ordinance to create Section 15.43 of the Code of Ordinances of the City of La Crosse entitled Traditional Neighborhood Development District Regulations.

Dated this 9th day of November, 2001.

Teri Lehrke, City Clerk
City of La Crosse

(Do not publish anything below this line)
Publish: November 13 & 20, 2001
One (1) Affidavit
Charge at "Email" rate

AN ORDINANCE to create Section 15.43 of the Code of Ordinances of the City of La Crosse entitled Traditional Neighborhood Development District Regulations.

THE COMMON COUNCIL of the City of La Crosse do ordain as follows:

SECTION I: Subsection 15.43 of the Code of Ordinances of the City of La Crosse is hereby created to read as follows:

15.43: PLANNED DEVELOPMENT DISTRICT: TRADITIONAL NEIGHBORHOOD DEVELOPMENT.

- (A) Proposed developments contemplated by an applicant to include design features described as "traditional neighborhood development" in Wisconsin Statutes sec. 66.1027(1)(c) (1999-2000 Statutes) may be considered for approval at locations determined appropriate by the City under this section, including appropriate conditions.
- (B) A document identified as "A MODEL ORDINANCE FOR TRADITIONAL NEIGHBORHOOD DEVELOPMENT," dated December, 2000, published by the University Extension pursuant to Wisconsin Statutes sec. 66.1027(2), shall serve as a non-exclusive guidebook to assist in further defining the various aspects of this form of urban design, along with such other sources of guidance the Plan Commission and local governing body may choose to consult.

SECTION II: This ordinance shall take effect and be in force from and after its passage and publication.

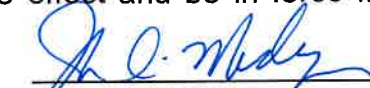

John D. Medinger, Mayor



Teri Lehrke, City Clerk

Passed: 12/13/01
Approved: 12/14/01
Published: 12/22/01

Law Update

By RICHARD LEHMANN

WAPA Legal Counsel
Boardman Law Firm
Madison, WI
rlehmann@boardmanlawfirm.com

For more Law Updates and more detail on the items printed here, please refer to the WAPA web page:
www.uwm.edu/Org/wapa/law/law.htm

January 1, 2002 Deadline Approaches For Adoption Of A Traditional Neighborhood Development Ordinance

A component of the 1999 Legislative adoption of Comprehensive Planning statute required all incorporated municipalities of 12,500 or more to adopt an ordinance allowing a "traditional neighborhood development." University Extension was directed to develop a "model ordinance." The Extension model has been published. Extension's version of a zoning district for this form of development is 38 pages long, with illustrations. The Boardman Law Firm Land Use Law Practice Group is recommending that municipalities consider something simpler, such as the draft below.

ORDINANCE NO. _____

CREATING ZONING ORDINANCE SECTION
_____: PLANNED DEVELOPMENT DISTRICT:
TRADITIONAL NEIGHBORHOOD DEVELOPMENT

PLANNED DEVELOPMENT DISTRICT:
TRADITIONAL NEIGHBORHOOD DEVELOPMENT

Proposed developments contemplated by an applicant to include design features described as "traditional neighborhood development" in Wisconsin Statutes sec. 66.1027(1)(c) (1999-2000 Statutes) may be considered for approval at locations determined appropriate by the City/Village under this section, including appropriate conditions.

A document identified as "A MODEL ORDINANCE FOR TRADITIONAL NEIGHBORHOOD DEVELOPMENT," dated December, 2000, published by the University of Wisconsin Extension pursuant to Wisconsin Statutes sec. 66.1027(2), shall serve as a non-exclusive guidebook to assist in further defining the various aspects of this form of urban design, along with such other sources of guidance the Plan Commission and local governing body may choose to consult.

Consistency Between Planning and Zoning

Starting in 2010, the rule of law in Wisconsin will be that all zoning and other land use actions must be consistent with a comprehensive plan. This rule is on the law books, with the delayed, 2010 effective date (Wisconsin Statutes sec. 66.1001(3)). Enforcement, as the law is currently written, will be by the courts. There is no precedent in Wisconsin, so the handling of consistency issues by courts in other states is of great interest.

On September 26, 2001 the District 4 Florida Court of Appeals decided a case in which a County Commission had issued zoning approval for a group of two story, 8-unit apartment buildings located next to a low density single family neighborhood. The County's comprehensive plan designated the apartment area for medium density multiple family residential at up to 8 units per acre. The zoning approval was for roughly 6.5 units per acre. There was, however, no transitioning of the density and the comprehensive plan called for the multiple family tract to keep its edge nearest the single family development in single family development as a means of transitioning.

A single family residential neighbor sued on grounds of lack of consistency between the approval and the plan. The neighbor's suit initially lost at the trial court after a certiorari-type review. At this point, the developer took out permits for 5 of the buildings and started construction. The neighbor sent a letter saying the construction was at the developer's risk and that the neighbor intended to seek a court order of demolition if the trial court's ruling were to be reversed.

An appeal court sent the case back for a second look, under a de novo review standard. This time the trial court struck down the zoning approval under the plan consistency test. The trial court then ordered the five constructed and partially constructed buildings removed. Three of the buildings had been occupied by that point.

The developer appealed. This time, the appeals court forbade more construction and more leasing, but allowed the existing leases to expire.

The second appeal resulted in the trial court's finding of inconsistency and the trial court's drastic remedy being upheld.

As to inconsistency, the appeals court found that the plan was specific as to the density transition. The municipality could not substitute landscaping for the density transition buffer, nor could the buffer be ignored.

As to remedy, the court notes that Florida law mandates each local government to have a comprehensive plan. It mandates all zoning to be consistent with those plans. It authorizes suits by aggrieved property owners to enforce the mandates. It allows those suits to ask for injunctive relief. These laws mean that consistency is a public policy command by the legislature, a command that should not be able to be waived by the courts. The courts are not allowed their usual power to "balance the equities" when these mandates are violated.

❖ A Model Ordinance for a Traditional Neighborhood Development ❖

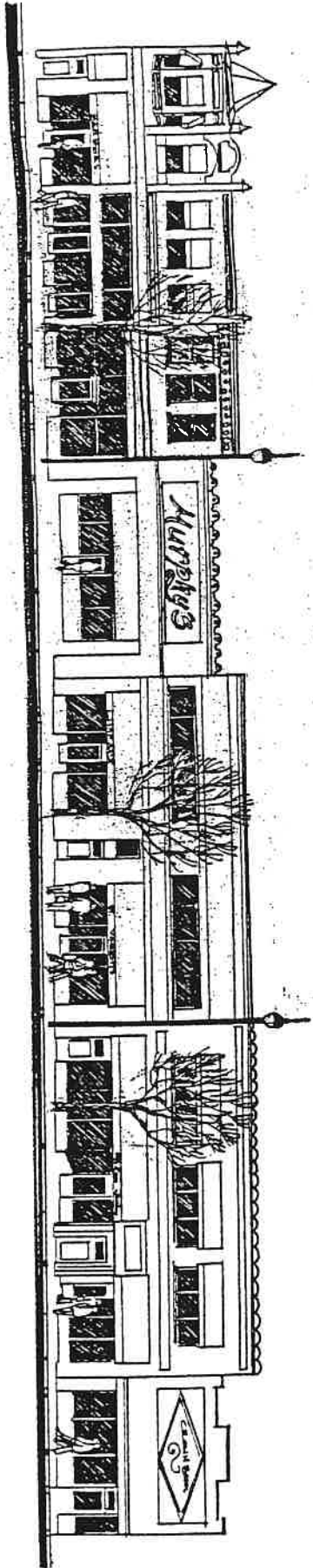

Prepared by Brian W. Ohm, James A. LaRio, Jr., and Chuck Strawser
December 2000



could do so very
needs PUD - TND

Authority

Section 66.1027 of the Wisconsin Statutes, part of Wisconsin's recent comprehensive planning and "smart growth" law, requires that the University of Wisconsin Extension develop a model ordinance for a traditional neighborhood development. This ordinance was prepared in response to that law. The law also requires that the model ordinance for a traditional neighborhood development:

"shall be presented to the chief clerk of each house of the legislature, and shall be referred immediately by the speaker of the assembly and the presiding officer of the senate to the appropriate standing committee in each house. The model ordinances shall be considered to have been approved by a standing committee if within 14 working days of the referral, the committee does not schedule a meeting for the purpose of reviewing the model ordinance. If the committee schedules a meeting for the purpose of reviewing the model ordinance, the ordinance may not be considered to have been approved unless the committee approves the model ordinance."

If the model ordinance for a traditional neighborhood development is approved, the law states that "[n]ot later than January 1, 2002, every city and village with a population of at least 12,500 shall enact an ordinance that is similar to the model traditional neighborhood development ordinance . . . although the ordinance is not required to be mapped."

Project Team

This document was prepared by Brian W. Ohm, J.D. (Associate Professor in the Department of Urban & Regional Planning at the University of Wisconsin-Madison and land use law specialist with the University of Wisconsin Extension), and James A. LaGro, Jr., Ph.D., R.L.A. (Associate Professor in the Department of Urban and Regional Planning), with assistance from Chuck Strawser (project assistant and graduate student in the Department of Urban & Regional Planning). The drawings were prepared by Tom Rogers (student in the Department of Landscape Architecture, University of Wisconsin-Madison).

Acknowledgments

The following individuals reviewed drafts of the ordinance and provided comments on the ordinance: John Hyslop, City of Milwaukee Department of City Development; Rob Kennedy and Allison Semandel, Citizens for a Better Environment; Dave Cieslewicz, 1000 Friends of Wisconsin; Brad Murphy, City of Madison Department of Planning and Development; Mike Slavney, Vandewalle & Associates, Richard Lehmann, Boardman Law Firm; Betty Nordeng, East Central Wisconsin Regional Planning Commission; Jerry Deschane, Wisconsin Builders Association; Jay Tappen, West Central Wisconsin Regional Planning Commission; Tom Larson, Wisconsin Realtors Association; Kevin Pomeroy, Wisconsin Main Street Program; Mike Maki, City of Kenosha Department of City Development; Bill Preboski, Dane County Regional Planning Commission; Mary Trout, HOME program manager for the Department of Administration; Jerry Braatz, Calumet County UW-Extension; Philip Schultz, Horizon Development Group; Dan Olson, City of Green Bay; Jeff Batovsky, Wisconsin Manufactured Housing Association; Land Use Team Members, Wisconsin Department of Natural Resources; Anna Haines, University of Wisconsin-Stevens Point/Extension; Steve Steinhoff, Dane County Department of Planning and Development; Carl Korfmancher, Applied Ecological Services, and Planning and Design Institute, Inc.

❖ A Model Ordinance for a Traditional Neighborhood Development ❖

Table of Contents

Introduction to the Model Ordinance

Principles and Objectives of Traditional Neighborhood Development

Preparation of this Ordinance and Additional Resources

1. GENERAL PROVISIONS
 - 1.1 Statutory Authorization
 - 1.2 Purpose
 - 1.3 Applicability
 - 1.4 Fees
 2. DEFINITIONS
 3. APPLICATION PROCEDURES AND APPROVAL PROCESS
 - 3.1 Initial Conference
 - 3.2 General Implementation Plan
 - 3.3 Specific Implementation Plan
 - 3.4 Amendments to the Specific Implementation Plan
 - 3.5 Subdivision of Land
 - 3.6 Ownership and Maintenance of Public Space
 - 3.7 Recording of Documents
 4. TRADITIONAL NEIGHBORHOOD DEVELOPMENT DESIGN GUIDELINES
 - 4.1 Neighborhood Uses
 - 4.2 Development Units
 - 4.3 Open Space
 - 4.4 Stormwater Management
 - 4.5 Lot and Block Standards
 - 4.6 Circulation Standards
 - 4.7 Architecture Standards
 - 4.8 Landscaping and Screening Standards
-

Introduction to the Model Ordinance

This publication includes the text of the model ordinance for a traditional neighborhood development required by Section 66.1027 of the Wisconsin Statutes, part of Wisconsin's recent "smart growth" law. The publication begins with a brief overview of the principles and objectives of traditional neighborhood development. These principles and objectives should be used to guide cities and villages in the development of local ordinances for traditional neighborhood development. The ordinance text begins on page 7. In addition to the ordinance text, the publication includes a commentary on the ordinance text. This is to make the document easier to understand and guide local officials and others interested in traditional neighborhood development.

The law requires that this ordinance be submitted to the Wisconsin Legislature by January 1, 2001, for approval. If approved, by January 1, 2002, every city and village with a population of at least 12,500 must enact an ordinance that is similar to this model traditional neighborhood development ordinance. The ordinance is meant as a guide and is **not** intended to be adopted "as is." **Each community must adapt the language and concepts of the ordinance to fit the unique circumstances found in that community.** The critical goal for cities and villages is that they adopt ordinances that reflect the principles and objectives of traditional neighborhood development.

This model ordinance is written in a format similar to some planned development district or planned unit development ordinances. It is written in this format because of the provision in the law that "the ordinance is not required to be mapped." Cities and villages may, at their option, develop the traditional neighborhood development ordinance following a different format. For example, a city or village may want to develop the ordinance as an overlay zoning ordinance or as a floating zoning district. Cities and villages should review their existing development review processes and adopt a streamlined review process that encourages the use of traditional neighborhood development principles and does not create a disincentive to the use of the traditional neighborhood development ordinance.

The traditional neighborhood development ordinance should provide an alternative to conventional ordinances and planned unit developments. Communities may also need to adapt other applicable ordinances, to ensure they are consistent with principles of traditional neighborhood development.

Principles and Objectives of Traditional Neighborhood Development

The "smart growth" law defines "traditional neighborhood development" to mean: "compact, mixed use neighborhood where residential, commercial and civic buildings are within close proximity to each other." It is a planning concept that is based on traditional small town and city neighborhood development principles. Traditional neighborhood development is, in part, a reaction to the often inefficient use of land and infrastructure and lack of a sense of community in many newer developments.

Traditional neighborhood development is found in the older parts of Wisconsin's cities and villages, parts that often developed prior

❖ A Model Ordinance for a Traditional Neighborhood Development ❖

to World War II. More recent examples are found in the older parts of Greendale, a "greenbelt" community built by the federal government near Milwaukee in the 1930s, and Middleton Hills, a new development begun in the 1990's in Middleton near Madison. Interest among consumers in traditional neighborhood development appears to be growing with other traditional neighborhood development projects in the planning stages (*Wisconsin State Journal*, 10/08/00). Traditional neighborhood development is one of a variety of planning concepts that share similar themes. These models include neo-traditional development, new urbanism, urban villages, hamlets, compact communities, transit-oriented development, pedestrian pockets, and the revitalization of existing traditional towns. This model ordinance draws upon a number of these models as appropriate for Wisconsin cities and villages.

The concept of traditional neighborhood development is the subject of a growing body of literature. While there is no single model for a traditional neighborhood development, certain principles define this type of development. Understanding the principles and objectives of traditional neighborhood development is an important in the process of developing a traditional neighborhood development ordinance. Cities and villages need to prepare comprehensive plans that provide a context for traditional neighborhood developments. As part of this planning process, cities and villages should analyze the development patterns and designs of the past to provide a context for the specific standards contained in the ordinance. These principles are discussed below and were used to guide the development of this model ordinance. As cities and villages modify the model ordinance to meet the unique circumstances found within their communities, the ordinances developed should seek to achieve these principles:

Compact Development

Traditional neighborhood developments are compact. Compact development patterns (for both residential and commercial uses), can promote a more efficient use of land and lower the costs of providing public infrastructure and services.

Compact development also means the development is designed for the human scale. The human scale is defined as "the relationship between the dimensions of the human body and the proportion of the spaces which people use." (Nelessen, 135). This includes paying attention to walking distances, the height of buildings, the design of street lights and signs, sidewalks, and other features.

Compact development can also promote social interaction by including civic spaces such as parks and public buildings. It also means residential, commercial, and civic buildings are within close proximity of each other which can encourage people to walk between the various uses.

Mixed Uses

Traditional neighborhood developments are designed to include a mixture of uses. This means that nonresidential land uses, such as commercial, civic and open space, are mixed with residential land uses. Mixing land uses can broaden the tax base of a community.

❖ A Model Ordinance for a Traditional Neighborhood Development ❖

Mixing uses also helps promote walking between the various uses. Different modes of transportation are promoted in the community such as walking, bicycles, transit, and automobiles.

Mixed use also provides a community center or focus. For example, the community center may be a public facility such as a park, recreational facility, school, or library, or it may be a retail area. Mixed use also means promoting a mix of housing types and sizes to accommodate households of all ages, sizes, and incomes. This means varying lots sizes and densities, and allowing other types of housing such as attached single-family residences, townhomes, duplexes, fourplexes, and specialty housing for seniors. Mixed use may also mean that housing is provided in the same building above commercial uses such as shops or offices.

Multiple Modes of Transportation

Traditional neighborhood developments provide for access generally by way of an interconnected network of circulation systems which facilitate walking, bicycling, and driving. Streets are designed to promote the safe and efficient use of different transportation modes. The interconnected street pattern is meant to limit the use of isolated cul-de-sacs which force the major circulation pattern of a community onto a few major roads. Short blocks in traditional grids create multiple routes and more direct ones for pedestrians, bicyclists, and motorists. Independent networks of sidewalks and bikeways complement the street network.

Traditional neighborhoods are also meant to be “pedestrian friendly.” Given the compact design of the neighborhood, streets will be narrower than what is required in conventional subdivision ordinances. Narrow streets and other “traffic calming” techniques help slow traffic down to promote pedestrian safety. Front porches and other amenities like, street trees, can also encourage walking. The mixed uses of traditional neighborhood developments will also promote walking if shops, offices, and public services and facilities are within walking distance.

Responsive to Cultural and Environmental Context

Significant cultural and environmental features of a site (amenities as well as constraints such as steep slopes, wetlands, critical wildlife areas, and highly erodible soils) should influence the way the site is developed. Developments with a clear “sense of place” require careful design and siting of buildings, streets, and other infrastructure. This includes the provision of adequate open space, neighborhood parks and playgrounds. Environmentally responsive stormwater management systems, the use of indigenous vegetation, and the energy conservation measures in the design and orientation of structures also help create “sustainable developments.” The historic and architectural character of the community are other important design influences.

Preparation of this Ordinance and Additional Resources

In developing this ordinance, relevant ordinances, design manuals, and traditional neighborhood development plans from various parts of the United States and abroad were collected and compared. Similarities were noted and inconsistencies were analyzed. Many of the ideas and concepts from these ordinances were used in the preparation of this ordinance. Other literature relevant to traditional neighborhood development was also reviewed. The resources consulted in preparing this ordinance include:

- Adams, C. F. 2000. Changing public policy. *Health Forum Journal*. 43: 38-40+ (January/February).
- Arendt, R. 1999. *Crossroads, Hamlet, Village, Town*. Planning Advisory Service Report Number 487/488. Chicago: American Planning Association.
- Audirac, I. & Sherman, A. H. 1994. An evaluation of traditional neighborhood design's social prescription: Postmodern placebo or remedy for suburban malaise? *Journal of Planning Education and Research*, 13: 161-173.
- Austin, Texas, City of. *Traditional Neighborhood District Ordinance*.
- Balousek, M. 2000. Developers are betting on tradition. *Wisconsin State Journal*. 1C, 8C (October 8).
- Barnett, J. 1992. Accidental cities: The deadly grip of outmoded zoning. *Architectural Record*, 94-101 (February).
- Belmont, North Carolina, City of. *Traditional Neighborhood Development Ordinance*.
- Bernan, M. A. 1996. The transportation effects of neotraditional development. *Journal of Planning Literature*, 10: 347-363.
- Bookout, L. W. 1992. Neotraditional town planning: A new vision for the suburbs? *Urban Land*, 51: 20-26 (January).
- Calthorpe Associates, et al. 1997. *Design for Efficient Suburban Activity Centers: Phase I Report*. Washington, DC: United States Department of Transportation, Federal Transit Administration.
- Calthorpe, P. 1993. *The Next American Metropolis: Ecology, Community, and the American Dream*. New York: Princeton Architectural Press.
- Cleek, L. W. 2000. New Urbanism sees green. *Architecture*, 89: 74-75, 144-145 (March).
- Christoforidis, A. 1994. New alternatives to the suburb: neo-traditional developments. *Journal of Planning Literature*, 8: 429-440.
- Crane, R. 2000. The influence of urban form on travel: An interpretive review. *Journal of Planning Literature*, 15: 3-23.
- Dade County, Florida. 1998. *Traditional Neighborhood Development Regulations (Draft)*.
- Davidson, M. and Dohnick, F. (eds.). 1999. *A Glossary of Zoning, Development, and Planning Terms*. Planning Advisory Service Report Number 491/492. Chicago: American Planning Association.
- Day, L. L. 2000. Choosing a House: The relationship between dwelling type, perception of privacy, and residential satisfaction. *Journal of Planning Education and Research*, 19: 265-275.
- Delsohn, G. 1994. Peter's Pockets. *Planning*, 60, 18+ (February).
- Duany, A. No date. Suburban sprawl or livable neighborhoods. Presentation to the Planners Training Service.
- Duany, A., Plater-Zyberk, E., and Speck, J. 2000. *Suburban Nation: The Rise of Sprawl and the Decline of the American Dream*. New York: North Point Press.

❖ A Model Ordinance for a Traditional Neighborhood Development ❖

- Duany Plater-Zyberk & Company. 2000. *City of Columbus, Ohio, Integrated Traditional Neighborhood Development Code (Draft)*.
- Duany Plater-Zyberk & Company. 1998. *Traditional Neighborhood Development Regulations for Dade County, Florida*.
- Duany Plater-Zyberk & Company. 1994. *Middleton Hills General Implementation Plan*.
- Duany Plater-Zyberk & Company. 1995. *Middleton Hills Specific Implementation Plan*.
- Fainstein, S. S. 2000. New directions in planning theory. *Urban Affairs Review*, 35: 451-478.
- Gainesville, Florida. 1999. *Traditional Neighborhood Development Floating Zoning District*.
- Hauglwout, A. F. Summer 2000. The paradox of infrastructure investment: Can a productive good reduce productivity? *Brookings Review*, 40-43.
- Hinslaw, M. 2000. Rezone or dezone? Sometimes it makes sense to start from scratch. *Planning*. 12-15 (June).
- Huntersville, North Carolina. Town of. 1996. *Zoning Ordinance*.
- Institute of Transportation Engineers. 1997. *Traditional Neighborhood Street Design Guidelines: A Proposed Recommended Practice of the Institute of Transportation Engineers*.
- Jacksonville, Florida. 1997. *Traditional Neighborhood Development District Ordinance*.
- Langdon, P. 1988. A good place to live. *Atlantic Monthly*, 39-60 (March).
- Lerabe, C. A. 1995. *Preparing A Conventional Zoning Ordinance*. Planning Advisory Service Report Number 460. Chicago: American Planning Association.
- Main Street Center. 1999. *Keeping Up Appearances*. Washington, DC: National Trust for Historic Preservation.
- Marcus, C. C. 2000. Looking back at Village Homes: Has New Urbanism thrown the baby out with the bathwater? *Landscape Architecture*, 128, 125 (July).
- Middleton, Wisconsin. 1984. *Zoning Ordinance*.
- Minnesota, State of. 2000. *From Policy to Reality: Model Ordinances for Sustainable Development*. St. Paul: Minnesota Planning.
- Nelessen, A. C. 1994. *Visions for a New American Dream: Process, Principles and an Ordinance to Plan and Design Small Communities*. Chicago: American Planning Association Planners Press.
- North Carolina Department of Transportation, Division of Highways. 2000. *Traditional Neighborhood Development (TND) Guidelines*.
- Oregon Transportation and Growth Management Program. 1999. *Model Development code and User's Guide for Small Cities*.
- Oregon Transportation and Growth Management Program. 1998. *The Principles of Smart Development*. Planning Advisory Service Report Number 479. Chicago: American Planning Association.
- Orlando, Florida. 1993. *Designed Community Ordinance*.
- Piwoni, J., Reed, D., and Rynh, D. 1990. *Design Guidelines for the Historic Third Ward District, Milwaukee, Wisconsin*.
- Planning and Design Institute, Inc. 1996. *The Midtown Neighborhood Triangle Plan: Urban Design and Development of a Traditional Milwaukee Neighborhood*.
- Rymer, R. 1996. Back to the future: Disney reinvents the company town. *Harper's Magazine*, 65-71, 75-78 (October).

❖ A Model Ordinance for a Traditional Neighborhood Development ❖

- Sutro, S. 1990. *Reinventing the village*. Planning Advisory Service Report Number 430. Chicago: American Planning Association.
- Tu, C. C. & Eppli, M. J. 1999. Valuing new urbanism: The case of Kentlands. *Real Estate Economics*, 27: 425-451.
- Talen, E. 1999. Sense of community and neighborhood form: An assessment of the social doctrine of new urbanism. *Urban Studies*. 1361-1379 (July).
- Washington State Community Trade and Economic Development, LMN Architects, Kato & Warren, Inc. 1998. *Model Code Provisions: Urban Streets and Subdivisions*.
- Western Australia, State of. 2000. *Liveable Neighbourhoods*. (Edition 2.) Perth: Western Australian Planning Commission.

❖ A Model Ordinance for a Traditional Neighborhood Development ❖

Ordinance Language

Commentary

1. General Provisions

1.1 Statutory Authorization. This ordinance is adopted pursuant to the authority contained in sections 62.23 and 66.1027 of the Wisconsin Statutes.

This ordinance will be part of a larger set of ordinances governing land use. Cities and villages required to adopt the ordinance must modify the ordinance to provide the best fit within the overall context of their existing land use ordinances.

1.2 Purpose. The purpose of this ordinance is to allow the optional development and redevelopment of land in [name of city/village] consistent with the design principles of traditional neighborhoods. A traditional neighborhood:

All references in the ordinance appearing between brackets [] are to be filled in with the appropriate reference by the jurisdiction adopting the ordinance.

1. Is compact;
2. Is designed for the human scale;
3. Provides a mix of uses, including residential, commercial, civic, and open space uses in close proximity to one another within the neighborhood;
4. Provides a mix of housing styles, types, and sizes to accommodate households of all ages, sizes, and incomes;
5. Incorporates a system of relatively narrow, interconnected streets with sidewalks, bikeways, and transit that offer multiple routes for motorists, pedestrians, and bicyclists and provides for the connections of those streets to existing and future developments;
6. Retains existing buildings with historical features or architectural features that enhance the visual character of the community;
7. Incorporates significant environmental features into the design;
8. Is consistent with the [City/Village]'s comprehensive plan.

The purpose statement should reflect the principles and objectives of traditional neighborhood development.

1.3 Applicability. The traditional neighborhood development ordinance is an alternative set of standards for development within the [City/Village] for new development of [15 acres or more] contiguous to existing development, redevelopment or infill development of [10 acres or more].

A city or village adopting an ordinance for a traditional neighborhood development may want to designate standards for the minimum size of traditional neighborhood developments and location.

1.4 Fees. The [Common Council/Village Board] may, by resolution, establish fees for the administration of this ordinance.

❖ A Model Ordinance for a Traditional Neighborhood Development ❖

2. Definitions

The following definitions shall be observed and applied, except when the context clearly indicates otherwise. Words used in the present tense shall include the future tense. Words used in the singular form shall include the plural form. Words used in the plural form shall include the singular. The word "shall" is mandatory and the word "may" is permissive.

Cities and villages should examine the definitions currently in their ordinances and how those definitions meet the goals and objectives of traditional neighborhood development.

- 2.1 **Accessory Building** - a detached subordinate structure, the use of which is incidental to that of the principal structure and located on the same lot therewith.
- 2.2 **ADT** - average daily traffic volumes of vehicles on a street.
- 2.3 **Affordable housing** - housing in which mortgage, amortization, taxes, insurance, and condominium and association fees, if any, constitute no more than [28] percent of gross household income for a household of the size which may occupy the unit. In the case of dwelling units for rent, housing that is affordable means housing for which the rent and utilities constitute no more than [30] percent of gross annual household income for a household of the size which may occupy the unit.
- 2.4 **Alley** - a public or private way permanently reserved as a secondary means of access to abutting property.
- 2.5 **Arterial** - a major street for carrying a large volume of through traffic in the area, normally controlled by traffic signs and signals.
- 2.6 **Block** - a unit of land bounded by streets or by a combination of streets and public land, railroad rights-of-way, waterways, or any other barrier to the continuity of development.
- 2.7 **Building Height** - the limit to the vertical extent of a building. The building height may be prescribed as a maximum number of stories or as a dimension

❖ A Model Ordinance for a Traditional Neighborhood Development ❖

Ordinance Language

Commentary

from sidewalk grade to the eave. The height limit shall not apply to attics, raised basements, chimneys, machine rooms, or similar structures.

2.8 Building Scale - the relationship between the mass of a building and its surroundings, including the width of street, open space, and mass of surrounding buildings. Mass is determined by the three-dimensional bulk of a structure: height, width, and depth.

2.9 Building Setback, Front - the distance from the street right-of-way line to the closest point of the foundation of a building or projection thereof.

2.10 Collector - a street designed to carry moderate volumes of traffic from local streets to arterial streets or from arterial to arterial.

2.11 Common Open Space - squares, greens, neighborhood parks, [city/village] parks, and linear environmental corridors owned and maintained by the [city/village].

2.12 Curb Radius - the curved edge of streets at an intersection measured at the outer edge of the street curb or of the parking lane.

2.13 Lot - a parcel of land occupied or intended for occupancy by a use permitted in this ordinance, including one main building, together with any accessory buildings, open spaces, and parking spaces required by this ordinance and having its principal frontage upon a street or upon an officially approved place.

2.14 Lot Line - the property lines bounding the lot.

2.15 Lot Width - the horizontal distance between side lot lines measured at the front setback.

2.16 Net acre - an acre of land excluding street rights-of-way and other publicly-dedicated improvements such as parks, open space, and stormwater detention

❖ A Model Ordinance for a Traditional Neighborhood Development ❖

Ordinance Language

Commentary

and retention facilities.

2.17 Principal Building - a building in which the primary use of the lot on which the building is located is conducted.

2.18 Queuing - the use of one travel lane on local streets with parking (usually an intermittent parking pattern) on both sides.

2.19 Secondary Dwelling Unit - An additional dwelling unit located within the principal dwelling on the lot, in a freestanding building or above a residential garage.

2.20 Story - a space in a building between the surface of any floor and the surface of the next floor above, or if there is no such floor above, then the space between such floor and the ceiling or roof above.

2.21 Street - a strip of land, including the entire right-of-way, publicly or privately owned, serving as a means of vehicular travel, and furnishing access to abutting properties, which may also be used to provide space for sewers, public utilities, shade trees, and sidewalks.

2.22 Traditional Neighborhood - a compact, mixed use neighborhood where residential, commercial and civic buildings are within close proximity to each other.

This definition is derived from Wisconsin "smart growth" law, Wis. Stat. § 66.1027(1)(a).

3. Application Procedure and Approval Process

Prior to the issuance of any permits for development within a Traditional Neighborhood Development, the following steps shall be completed according to the procedures outlined in this section:

1. the applicant shall have had an initial conference;
2. a General Implementation Plan and a zoning map amendment to a Traditional Neighborhood Development District shall be approved by the [Common Council/Village Board];
3. a Specific Implementation Plan shall be approved by the [Common Council/Village Board].

3.1 Initial conference. Before submitting an application for a Traditional Neighborhood Development project, the applicant shall schedule an appointment and meet with the [Planner, municipal staff, Plan Commission] to discuss the procedure for approval of a Traditional Neighborhood Development project, including submittal requirements and design standards.

3.2 General Implementation Plan

1. General Implementation Plan Process. Following the initial conference, the applicant shall submit a general implementation plan to the [City/Village] planner or municipal staff together with an application for a zoning map amendment to Traditional Neighborhood Development District.

- a. Within [20] days, the Plan Commission shall conduct a public hearing to consider the zoning map amendment request and to consider a recommendation for approval or disapproval of a general implementation plan. At this public hearing, the Plan Commission shall receive a report from the [City/Village] planner or municipal staff recommending approval, disapproval or approval with specified modifications. Within [20] days, the Plan Commission shall recommend the [Common

The development review process varies significantly in cities and villages across the state. The "Application Procedure and Approval Process" outlined here provides one approach. Cities and villages are not required to adopt this exact process. Rather, cities and villages need to examine their development review processes to find ways that the review process can be streamlined so developers are encouraged to use the traditional neighborhood development ordinance. Cities and villages should examine zoning procedures, special zoning districts and special procedures that may apply to those districts, planned unit development procedures, subdivision review procedures, and procedures before other bodies such as architectural or design review commissions. Depending on what the examination reveals, cities and villages need to develop an efficient and expedited review process for traditional neighborhood developments that encourages the implementation of this ordinance.

Communities may want to require only one development plan for smaller projects and/or streamline the planning requirements in this model ordinance to require one development plan in addition to the plans and documentation required by their subdivision ordinance.

❖ A Model Ordinance for a Traditional Neighborhood Development ❖

Council/Village Board] either:

- i. approve the General Implementation Plan and zoning map amendment,
- ii. approve the General Implementation Plan and zoning map amendment with modifications, or
- iii. deny the General Implementation Plan and zoning map amendment.

b. The [Common Council/Village Board] shall receive the recommendation from the [Plan Commission] and a report from the Planner or municipal staff. Upon due consideration, the [Common Council/Village Board] shall either:

- i. approve the General Implementation Plan and zoning map amendment,
- ii. approve the General Implementation Plan and zoning map amendment with modifications, or
- iii. deny the General Implementation Plan and zoning map amendment.

2. General Implementation Plan Submittal Requirements. The purpose of the general implementation plan is to establish the intent, density, and intensity for a proposed development. The General Implementation Plan shall include the following:

a. A general location map of suitable scale, but no less than one inch = [200] feet, which shows the location of the property within the community and adjacent parcels including locations of any public streets, railroads, major streams or rivers and other major features within [1000] feet of the site.

b. A site inventory and analysis to identify site assets or resources, and constraints, including but not limited to floodplains, wetlands and soils classified as “poorly drained” or “very poorly drained,” soils with bedrock at or within 42 inches of the surface, utility easements for high-tension electrical transmission lines (>69KV), steep slopes greater than

❖ A Model Ordinance for a Traditional Neighborhood Development ❖

[15%], and brownfields.

- c. A conceptual site plan, at a scale of no less than one inch = [100] feet, which indicates topography in [two] foot contours for sites with 15 feet or more of local relief, or one foot contours for local sites with less than 15 feet of local relief, consisting of a map with proposed features and existing site features and uses that will remain. These features should include building outlines, location of streets, transit stops, drives and parking areas, pedestrian and bicycle paths, service access areas for receiving material and trash removal, and other impervious surfaces. The location of proposed and existing to remain trees and shrubs should also be included, along with any other significant features.
- d. A conceptual storm water management plan identifying the proposed patterns of major stormwater runoff, locations of stormwater infiltration areas, and other significant stormwater best management practices.
- e. Identification of the architectural style(s) of the Traditional Neighborhood Development and the accompanying site design style(s). The design style of the Traditional Neighborhood Development shall be conveyed with drawings or computer simulations of typical proposed building elevations (including dimensions of building height and width, and facade treatment).
- f. A written report which provides general information about the covenants, conservation easements, or agreements which will influence the use and maintenance of the proposed development. The report shall also describe the site conditions and the development objectives.
- g. Any other information deemed necessary by the [City/Village] in order to evaluate plans.
- h. [Five] copies of the above information shall be submitted plus [one]

reduced set no larger than 8-1/2 inches by 11 inches.

3.3

Specific Implementation Plan. The purpose of the Specific Implementation Plan is to establish a detailed development proposal. The Specific Implementation Plan can be proposed, reviewed, and acted upon as whole or in part or phases.

1. Specific Implementation Plan Process. Following approval of the General Implementation Plan, the applicant shall submit a Specific Implementation Plan to the [planner, municipal staff, Plan Commission].

a. Within [30] days following receipt of the Specific Implementation Plan, the Plan Commission shall receive a report from the [planner, planning department, municipal staff] recommending approval, disapproval or approval with specified modifications. The Plan Commission shall determine that the proposed Specific Implementation Plan is in substantial conformance with the approved General Implementation Plan. Upon due consideration, the Plan Commission shall recommend that the [Common Council/Village Board] either:

- i. approve the Specific Implementation Plan as being in substantial conformance with the General Implementation Plan;
- ii. approve the Specific Implementation Plan as being in substantial conformance with the General Implementation Plan with specified modifications; or
- iii. deny the Specific Implementation Plan.

b. Following Plan Commission recommendation, the [Common Council/Village Board] shall receive the recommendation from the Plan Commission and the report from the planner or municipal staff. Upon due consideration, the [Common Council/Village Board] shall either:

- i. approve the Specific Implementation Plan as being in substantial

- conformance with the General Implementation Plan;
- ii. approve the Specific Implementation Plan as being in substantial conformance with the General Implementation Plan with specified modifications; or
- iii. deny the Specific Implementation Plan.

2. Specific Implementation Plan Submittal Requirements. The applicant shall submit a series of plans, maps, and written materials which include the following information:

- a. A general location map of suitable scale which shows the boundaries and dimensions of the property within the context of the community and adjacent parcels, including locations of any public streets, railroads, major streams or rivers and other major features within 1000 feet of the site, along with a legal description of the property.
- b. A site inventory and analysis to identify site assets or resources, and constraints, including but not limited to floodplains, wetlands and soils classified as “poorly drained” or “very poorly drained,” soils with bedrock at or within 42 inches of the surface, utility easements for high-tension electrical transmission lines (>69KV), slopes greater than [15%], and brownfields.
- c. A site plan, including proposed topographic contours at one foot intervals, with the following information:
 - i. the location of proposed structures and existing structures that will remain, with height and gross floor area noted;
 - ii. the location of street and pedestrian lighting, including lamp intensity and height;
 - iii. the location of proposed open space,
 - iv. the circulation system indicating pedestrian, bicycle, and motor vehicle movement systems, including existing and proposed public

- streets or right-of-ways; transit stops; easements or other reservations of land on the site; the location and dimensions of existing and proposed curb cuts, off-street parking and loading spaces, include service access for receiving and trash removal; sidewalks and other walkways.
- v. location of all trees, shrubs, and ground cover proposed or existing to remain on the site.
- d. A stormwater management plan for the site. The grading plan shall show existing and proposed ground elevations with contours (one-foot contour interval) and spot elevations at significant high points, low points, and transition points. The grading plan shall also note the finished ground floor elevations of all buildings. The plan shall also show the locations of all storm drainage sewers and structures, and infiltration or detention/retention structures; and all wetlands on the site, using the Federal Manual For Identifying and Delineating Jurisdictional Wetlands, and copies of documents completed in making the wetlands identification.
- e. Detailed elevations of all proposed commercial buildings and typical elevations of residential buildings. Scaled elevations should identify all signs, building materials and percentage of ground floor commercial facade in windows; the location, height and material for screening walls and fences, including outdoor trash storage areas, electrical, mechanical and gas metering equipment, storage areas for trash and recyclable materials, and rooftop equipment.
- f. A utilities plan showing underground and above ground lines and structures for sanitary sewers, electricity, gas, telecommunications, etc.
- g. A written report which completely describes the proposal and indicates covenants or agreements that will influence the use and maintenance of the proposed development. The report also shall describe the analysis of site conditions and the development objectives.

- h. Phasing plans, where applicable.
- i. Any other information deemed necessary by the [Common Council/Village Board] in order to evaluate plans.
- j. [Five] copies of the above information shall be submitted, plus [one] reduced set no larger than 8-1/2 inches by 11 inches.

3.4 Amendments to the Specific Implementation Plan. Minor changes to the Specific Implementation Plan adopted by the [Common Council/Village Board] may be approved by the Planning Department, provided that the changes do not involve:

1. Increases or decreases of less than [10%] in floor area of structures or number of dwelling units.
2. Change in exterior building material.
3. Alteration of any conditions attached or modification to the Specific Implementation Plan made by the [Common Council/Village Board].

A major change to a Specific Implementation Plan which is less restrictive than any conditions of approval for the initial Specific Implementation Plan, shall require approval by a majority vote of all members of the [Common Council/Village Board].

3.5 Subdivision of Land. If the Traditional Neighborhood Development involves the subdivision of land as defined in the [City/Village]'s subdivision ordinance, the applicant shall submit all required land division documents in accordance with the requirements of the subdivision ordinance and Chapter 236 of the Wisconsin Statutes. If there is a conflict between the design standards of the subdivision ordinance and the design guidelines of this ordinance, the provisions of this ordinance shall apply.

3.6 Ownership and Maintenance of Public Space. Provision shall be made for

❖ A Model Ordinance for a Traditional Neighborhood Development ❖

the ownership and maintenance of streets, squares, parks, open space, and other public spaces in a Traditional Neighborhood Development by dedication to the [City/Village].

- 3.7 Recording of Documents.** The following documents need to be filed by the applicant in the County Register of Deeds Office within [10 days] after approval of the document by the [Common Council/Village Board]: a certified copy of the zoning ordinance amendment designating a tract of land as a Traditional Neighborhood Development; the general implementation plan; and the specific implementation plan.

❖ A Model Ordinance for a Traditional Neighborhood Development ❖

4. Traditional Neighborhood Development Design Standards

4.1 Neighborhood Uses. In order to achieve the proximity necessary to make neighborhoods walkable, it is important to mix land uses. A traditional neighborhood development should consist of a mix of residential uses, a mixed use area, and open space as provided below:

A goal of traditional neighborhood developments is to include a mixture of uses such as residential, commercial, civic, and open space.

1. **A mix of residential uses** of the following types can occur anywhere in the traditional neighborhood development. For infill development, the mix of residential uses may be satisfied by existing residential uses adjacent to the Traditional Neighborhood Development.

A goal of traditional neighborhood developments is to promote a mix of housing types (such as attached single-family residences, townhomes, duplexes, fourplexes, and specially housing for seniors) to accommodate households of all ages, sizes, and incomes. Mixing housing types promotes affordability, meets the diverse needs of the housing consumer, and can make a community more walkable.

- a. Single-family detached dwellings, including manufactured homes;
- b. Single-family attached dwellings, including duplexes, townhouses, row houses;
- c. Multifamily dwellings, including senior housing;
- d. Secondary dwelling units (“granny flats”);
- e. “Special needs” housing, such as community living arrangements and assisted living facilities.

2. **Mixed use area**, of commercial, residential, civic or institutional, and open space uses as identified below. All residents should be within approximately 1/4 mile or a 5 minute walk from existing or proposed commercial, civic, and open space areas. Individual businesses should not exceed [6000] square feet in size.

a. **Commercial uses.**

- i. Food services (neighborhood grocery stores; butcher shops; bakeries; restaurants, not including drive-throughs; cafes; coffee shops; neighborhood bars or pubs);
- ii. Retail uses (florists or nurseries; hardware stores; stationery stores; book stores; studios and shops of artists and artisans);
- iii. Services (day care centers; music; dance or exercise studios;

A goal of traditional neighborhood developments is to provide a community center or focal point. In this ordinance, the term “mixed use area” is used to designate the community center. The mixing of uses in this area can reduce vehicle use and can broaden the tax base of the community. It can also help build community identity.

❖ A Model Ordinance for a Traditional Neighborhood Development ❖

Ordinance Language

Commentary

- iv. offices, including professional and medical offices; barber; hair salon; dry cleaning);
- iv. Accommodations (bed and breakfast establishments, small hotels or inns).

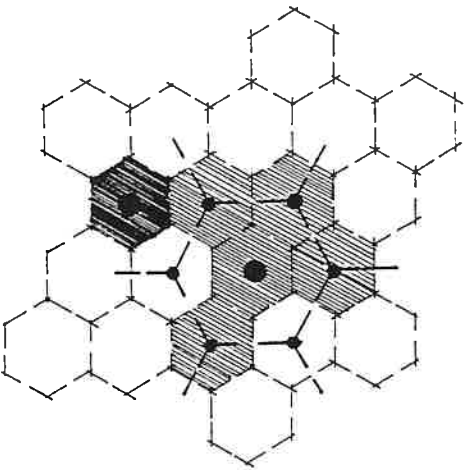
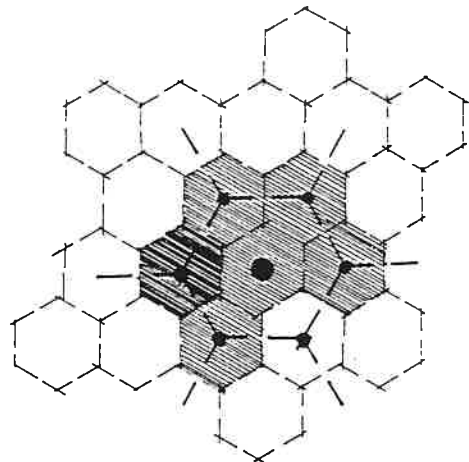

Figure 1. Plan-view conceptual diagrams of neighborhood commercial "service areas" (hexagons). Each hexagon represents a neighborhood with a mixed-use center (dot) that is within a five-minute walking distance of the neighborhood's edge. Clusters of neighborhoods (larger hexagon) can support more extensive commercial development than individual neighborhoods. The appropriate amount of commercial uses within a traditional neighborhood development depends on the location, or community context, of the new development (darker shaded hexagon).

❖ A Model Ordinance for a Traditional Neighborhood Development ❖

- b. Residential uses:
 - i. Single-family attached dwellings, including duplexes, townhouses, row houses;
 - ii. Multifamily dwellings, including senior housing;
 - iii. Residential units located on upper floors above commercial uses or to the rear of storefronts;
 - iv. "Live/work" units that combine a residence and the resident's workplace;
 - v. "Special needs" housing, such as community living arrangements or assisted living facilities.
- c. Civic or institutional uses.
 - i. Municipal offices, fire stations, libraries, museums, community meeting facilities, and post offices;
 - ii. Transit shelters;
 - iii. Places of worship;
 - iv. Educational facilities.
- d. Open space uses.
 - i. Central square;
 - ii. Neighborhood park;
 - iii. Playground.

Mixed use may also mean that housing is provided in the same building above commercial uses such as shops or offices.

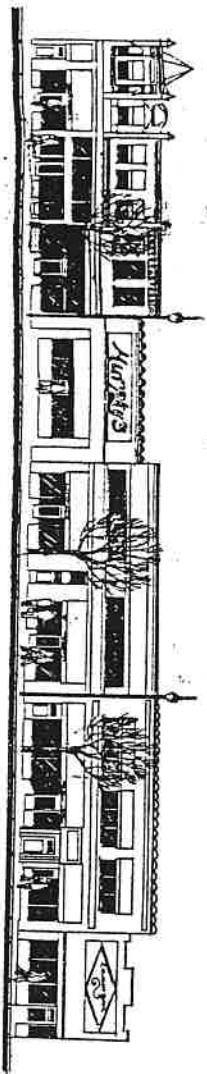

Figure 2. Elevation sketch of a typical "streetscape" within a mixed-use area. Architectural design, street furniture, and landscaping all contribute to an attractive, human-scaled environment with a distinct visual character.

❖ A Model Ordinance for a Traditional Neighborhood Development ❖

Ordinance Language

Commentary

3. **Open space** uses identified below should be incorporated in the traditional neighborhood development as appropriate. Large outdoor recreation areas should be located at the periphery of neighborhoods rather than central locations.
 - a. Environmental corridors;
 - b. Protected natural areas;
 - c. Community parks;
 - d. Streams, ponds, and other water bodies;
 - e. Stormwater detention/retention facilities.

A goal of traditional neighborhood development is to incorporate the significant environmental features of a site into the design of the development. This includes the provision of adequate open space for both active and passive recreational uses, use of open space as a visual amenity, and use of open space for stormwater management.

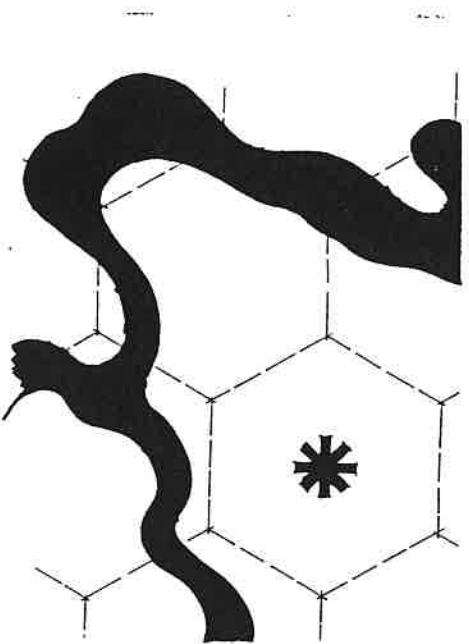

Figure 3. Plan-view diagram illustrating the importance of context in planning public open space. Large, contiguous open spaces are community-wide resources with environmental, aesthetic, recreational, and educational benefits. Smaller parks and open spaces (asterisk) should be located in neighborhoods (hexagons) that are not within easy walking distance of community parks and open space.

4.2 Development units. The number of residential dwelling units and the amount of nonresidential development (excluding open spaces) shall be determined as follows:

1. In areas devoted to mixed residential uses:
 - a. The number of single-family attached and detached units permitted shall be [5 - 8] dwelling units per net acre;
 - b. The number of multi-family units shall be [15 - 40] dwelling units per net acre.
 - c. Secondary dwelling units shall be permissible in addition to the number of dwelling units authorized under this section. However, the total number of secondary dwelling units shall not be more than [10 percent] of the total number of single-family attached and detached units.
 - d. For each affordable housing unit provided under this section, one additional dwelling unit shall be permitted, up to a maximum [15] percent increase in dwelling units.
2. In mixed use areas:
 - a. The number of single-family and multi-family dwelling units permitted shall be calculated the same as above plus an additional number of units not to exceed [10 percent] of the amount permitted above.
 - b. All dwelling units constructed above commercial uses shall be permissible in addition to the number of dwelling units authorized under this section. However, the total number of dwelling units shall not be increased by more than [10 dwelling units or 10 percent], whichever is greater.
 - c. The amount of nonresidential development should range from a minimum of [125] square feet of commercial floor area per residential dwelling unit to a maximum of [300] square feet of commercial floor area per dwelling unit.

A goal of traditional neighborhood development is that development is more compact.

❖ A Model Ordinance for a Traditional Neighborhood Development ❖

Ordinance Language

Commentary

4.3 Open Space. At least [20] percent of the gross acreage of the Traditional Neighborhood Development must be open space. Open space may include undevelopable areas such as steep slopes and wetlands, and stormwater detention and retention basins. At least [25] percent of the open space must be common open space dedicated to the public for parkland. [90] percent of the lots within the areas devoted to mixed residential uses shall be within a 1/4 mile or a 5 minute walk from common open space.

Open space is a significant part of a Traditional Neighborhood Development. The amount of open space dedicated to the public should reflect the needs generated by the intensity of the proposed Traditional Neighborhood Development. The open space should also be consistent with the city/villages plans for it's park and open space system.

4.4 Stormwater Management. The design and development of the traditional neighborhood development should minimize off-site stormwater runoff, promote on-site filtration, and minimize the discharge of pollutants to ground and surface water. Natural topography and existing land cover should be maintained/protected to the maximum extent practicable. New development and redevelopment shall meet the following requirements:

1. Untreated, direct stormwater discharges to wetlands or surface waters are not allowed.
2. Post development peak discharge rates should not exceed pre-development peak rates.
3. Post development patterns of stormwater runoff should approximate pre-development conditions.
4. Erosion and sediment controls must be implemented to remove 80% of the average annual load of total suspended solids.
5. Areas for snow storage should be provided unless the applicant provides an acceptable snow removal plan.
6. Redevelopment stormwater management systems should improve existing conditions and meet standards to the extent practicable.
7. All treatment systems or BMPs must have operation and maintenance plans to ensure that systems function as designed.

4.5 Lot and Block Standards.

1. **Block and lot size diversity.** Street layouts should provide for perimeter

Providing diversity in block and lot size can help to create an urban structure that is pedestrian friendly.

❖ **A Model Ordinance for a Traditional Neighborhood Development** ❖

blocks that are generally in the range of 200-400 feet deep by 400-800 feet long. A variety of lot sizes should be provided to facilitate housing diversity and choice and meet the projected requirements of people with different housing needs.

Short blocks in traditional grids create multiple routes and more direct ones for pedestrians, bicyclists, and motorists.

Lot and block design should promote development that is compatible with natural features, minimizes pedestrian and vehicular conflict, promotes street life and activity, reinforces public spaces, promotes public safety, and visually enhances development.

Lot design should allow for passive solar designs.

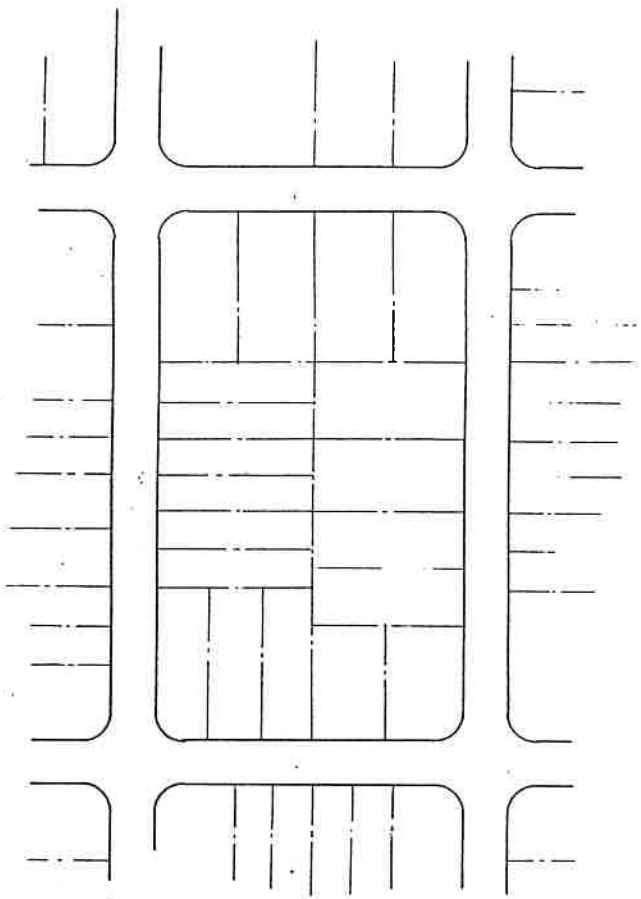

Figure 4. Plan-view diagram of a street grid showing a diversity of lot (parcel) sizes.

2. **Lot Widths.** Lot widths should create a relatively symmetrical street cross section that reinforces the public space of the street as a simple, unified public space.

Cities and villages should establish minimum and/or maximum lot sizes and setbacks that meet traditional neighborhood development design principles within the context of their community.

❖ A Model Ordinance for a Traditional Neighborhood Development ❖

blocks that are generally in the range of 200-400 feet deep by 400-800 feet long. A variety of lot sizes should be provided to facilitate housing diversity and choice and meet the projected requirements of people with different housing needs.

Short blocks in traditional grids create multiple routes and more direct ones for pedestrians, bicyclists, and motorists.

Lot and block design should promote development that is compatible with natural features, minimizes pedestrian and vehicular conflict, promotes street life and activity, reinforces public spaces, promotes public safety, and visually enhances development.

Lot design should allow for passive solar designs.

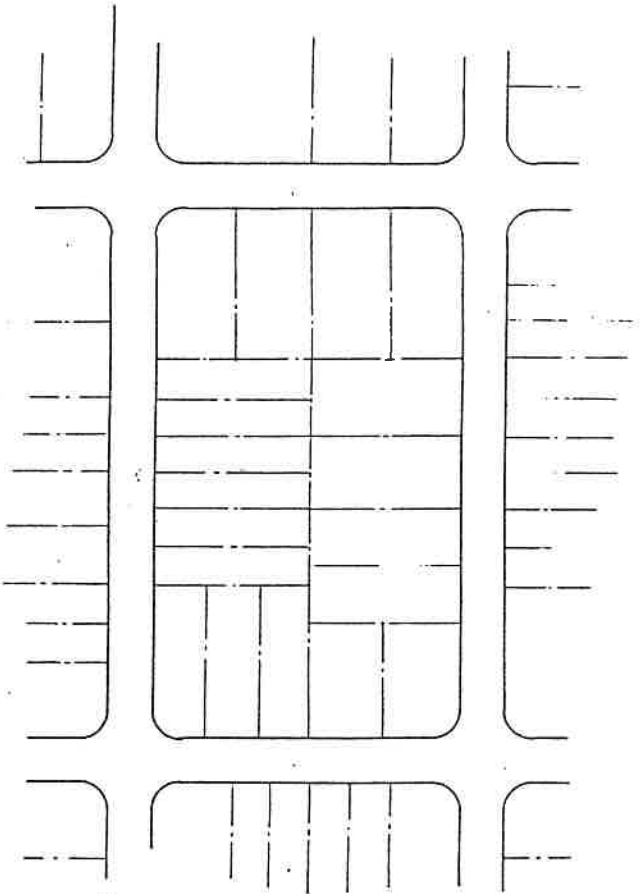

Figure 4. Plan-view diagram of a street grid showing a diversity of lot (parcel) sizes.

2. **Lot Widths.** Lot widths should create a relatively symmetrical street cross section that reinforces the public space of the street as a simple, unified public space.

Cities and villages should establish minimum and/or maximum lot sizes and setbacks that meet traditional neighborhood development design principles within the context of their community.

❖ A Model Ordinance for a Traditional Neighborhood Development ❖

3. **Building Setback, Front - Mixed Use Area.** Structures in the mixed use area have no minimum setback. Commercial and civic or institutional buildings should abut the sidewalks in the mixed use area.

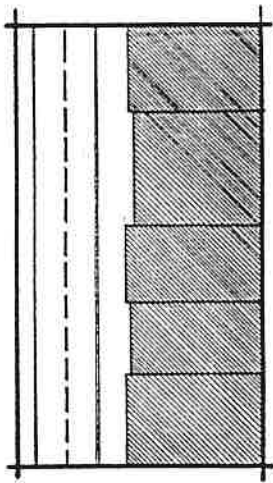

a.

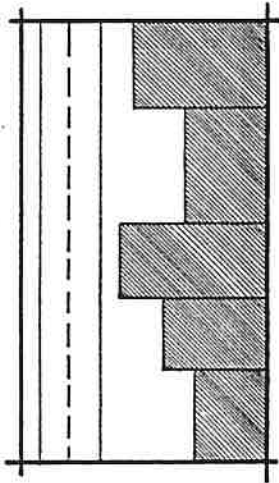

b.

Figure 5. Plan-view diagrams showing two alternatives for building setbacks from the street right-of-way in mixed-use areas. Relatively uniform setbacks (a) are preferable to widely varying building setbacks (b).

4. **Building Setback, Front - Areas of Mixed Residential Uses.** Single-family detached residences shall have a building setback in the front between [0 and 25] feet. Single-family attached residences and multifamily residences shall have a building setback in the front between [0 and 15] feet.

❖ A Model Ordinance for a Traditional Neighborhood Development ❖

Ordinance Language

Commentary

5. **Building Setback, Rear - Areas of Mixed Residential Uses.** The principal building on lots devoted to single-family detached residences shall be setback no less than [30] feet from the rear lot line.
6. **Side Setbacks.** Provision for zero lot-line single-family dwellings should be made, provided that a reciprocal access easement is recorded for both lots and townhouses or other attached dwellings, provided that all dwellings have pedestrian access to the rear yard through means other than the principal structure.

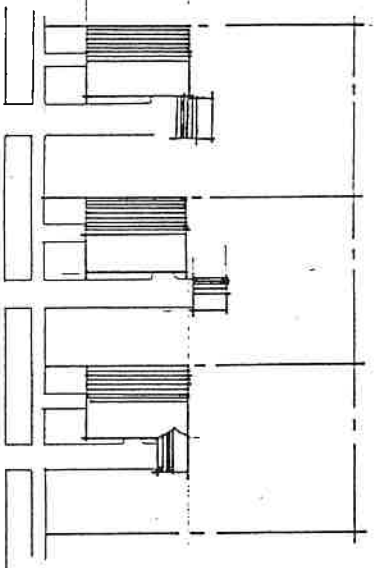

Figure 6. Plan-view diagram of the "zero-lot line" concept. A large side-yard on each parcel is created by uniformly eliminating one of the side-yard setbacks.

- 4.6 **Circulation Standards.** The circulation system shall allow for different modes of transportation. The circulation system shall provide functional and visual links within the residential areas, mixed use area, and open space of the traditional neighborhood development and shall be connected to existing and proposed external development. The circulation system shall provide adequate traffic capacity, provide connected pedestrian and bicycle routes (especially off street bicycle or multi-use paths or bicycle lanes on the streets), control through traffic, limit lot access to streets of lower traffic volumes, and promote safe and efficient mobility through the traditional neighborhood development.

A goal of a traditional neighborhood development is a vehicle circulation system that provides for access generally by way of an interconnected network of streets (such as a grid pattern). The interconnected street pattern is meant to limit the use of isolated cul-de-sacs which force the major circulation pattern of a community onto a few major roads.

❖ A Model Ordinance for a Traditional Neighborhood Development ❖

Ordinance Language

Commentary

1. **Pedestrian Circulation.** Convenient pedestrian circulation systems that minimize pedestrian-motor vehicle conflicts shall be provided continuously throughout the Traditional Neighborhood Development. Where feasible, any existing pedestrian routes through the site shall be preserved and enhanced. All streets, except for alleys, shall be bordered by sidewalks on both sides in accordance with the specifications listed in Table 1. The following provisions also apply:

Traditional neighborhoods should also be "pedestrian friendly," meaning they provide for pedestrian safety and convenience. An independent network of sidewalks and bikeways can also promote walking and reduce reliance on private vehicles.

- a. Sidewalks in residential areas. Clear and well-lighted sidewalks, [3-5 feet] in width, depending on projected pedestrian traffic, shall connect all dwelling entrances to the adjacent public sidewalk.
 - b. Sidewalks in mixed use areas. Clear and well-lighted walkways shall connect building entrances to the adjacent public sidewalk and to associated parking areas. Such walkways shall be [a minimum of 5 feet] in width.
 - c. Disabled Accessibility. Sidewalks shall comply with the applicable requirements of the Americans with Disabilities Act.
 - d. Crosswalks. Intersections of sidewalks with streets shall be designed with clearly defined edges. Crosswalks shall be well lit and clearly marked with contrasting paving materials at the edges or with striping.
2. **Bicycle Circulation.** Bicycle circulation shall be accommodated on streets and/or on dedicated bicycle paths. Where feasible, any existing bicycle routes through the site shall be preserved and enhanced. Facilities for bicycle travel may include off-street bicycle paths (generally shared with pedestrians and other non-motorized users) and separate, striped, 4 foot bicycle lanes on streets. If a bicycle lane is combined with a lane for parking, the combined width should be 14 feet.
3. **Public Transit Access.** Where public transit service is available or planned, convenient access to transit stops shall be provided. Where transit shelters are provided, they shall be placed in highly visible locations that promote security through surveillance, and shall be well-lighted.

❖ A Model Ordinance for a Traditional Neighborhood Development ❖

Ordinance Language

Commentary

4. **Motor Vehicle Circulation.** Motor vehicle circulation shall be designed to minimize conflicts with pedestrians and bicycles. Traffic calming features such as “queuing streets,” curb extensions, traffic circles, and medians may be used to encourage slow traffic speeds.

A goal of traditional neighborhood developments is narrower streets than what is required in conventional subdivision ordinances. Narrow streets and other “traffic calming” techniques help slow traffic down to promote pedestrian safety.

a. **Street Hierarchy.** Each street within a traditional neighborhood development shall be classified according to the following (arterial streets should not bisect a traditional neighborhood development):

Local street widths utilize a concept called “queuing” – the use of one travel lane on local streets with parking (usually an intermittent parking pattern) on both sides. At low traffic volumes, with intermittent parking, cars traveling in opposite directions must occasionally use the parking lane as a travel lane or wait for another car to pass.

i. **Collector.** This street provides access to commercial or mixed-use buildings, but it is also part of the [city/village]’s major street network. On-street parking, whether diagonal or parallel, helps to slow traffic. Additional parking is provided in lots to the side or rear of buildings.

The debate over the potential benefits of narrower streets are discussed in the Institute of Transportation Engineers’ 1997 publication, “Traditional Neighborhood Street Design Guidelines.”

ii. **Subcollector.** This street provides primary access to individual residential properties and connects streets of lower and higher function. Design speed is 25 mph.

iii. **Local Street.** This street provides primary access to individual residential properties. Traffic volumes are relatively low, with a design speed of 20 mph.

iv. **Alley.** These streets provide secondary access to residential properties where street frontages are narrow, where the street is designed with a narrow width to provide limited on-street parking, or where alley access development is desired to increase residential densities. Alleys may also provide delivery access or alternate parking access to commercial properties.

❖ A Model Ordinance for a Traditional Neighborhood Development ❖

Table 1: Attributes of Streets in a Traditional Neighborhood Development

	Collector	Subcollector	Local Street	Alley
Average Daily Trips	750 or more	750-1500	Less than 250	Not applicable
Right-of-Way	76-88 feet	48-72 feet	35-50 feet	12-16 feet
Auto travel lanes	Two or three 12 foot lanes	Two 10 foot lanes	Two 10 feet lanes, or one 14 feet (queuing) lane	Two 8 feet lanes for two-way traffic, or one 12 feet lane for one-way traffic
Bicycle lanes	Two 6 feet lanes combined with parking lanes	4 feet lanes with no parking, or 6 feet lanes combined with parking lanes	None	None
Parking	Both sides, 8 feet	None, one, or both sides, 8 feet	None or one side, 8 feet	None (access to individual drives & garages outside Right-of-way)
Curb and gutter	Required	Required	Not required	
Planting strips	Minimum 6 feet	Minimum 6 feet	Minimum 6 feet	None
Sidewalks	Both sides, 5 feet minimum	Both sides, 3-5 feet	Both sides, 3-5 feet	None

❖ A Model Ordinance for a Traditional Neighborhood Development ❖

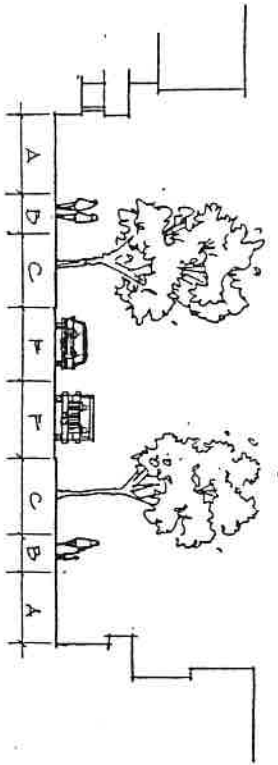

Figure 7a. Schematic sketch of a typical local street cross-section. Table 1 lists the recommended dimensions of each component: A) building setback from street right-of-way, B) walkway, C) planting area, F) travel lane.

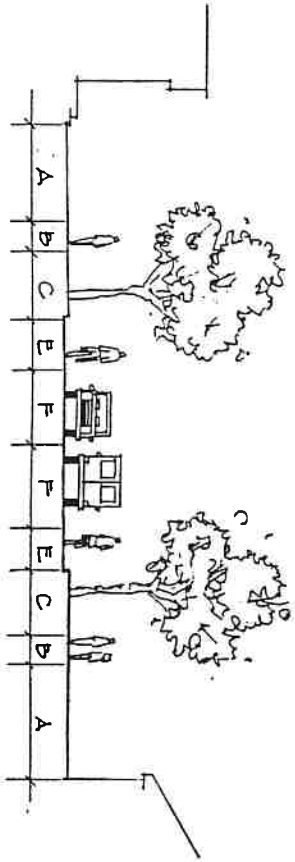

Figure 7b. Schematic sketch of a typical sub-collector street cross-section. Table 1 lists the recommended dimensions of each component: A) building setback from street right-of-way, B) walkway, C) planting area, E) bicycle lane, F) travel lane.

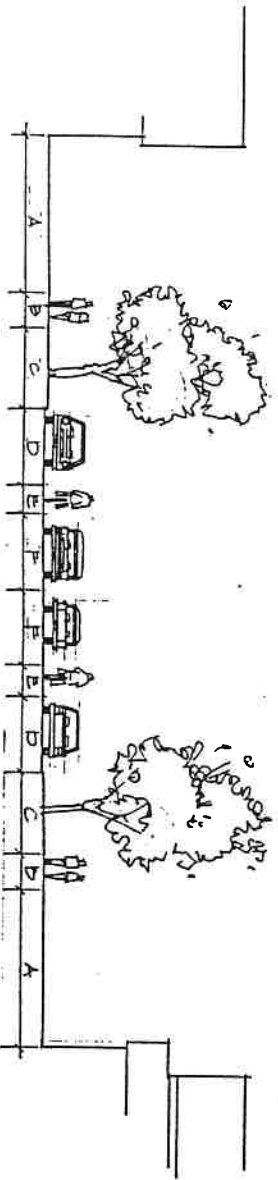

Figure 7c. Schematic sketch of a typical collector street cross-section. Table 1 lists the recommended dimensions of each component: A) building setback from street right-of-way, B) walkway, C) planting area, D) parking lane, E) bicycle lane, F) travel lane.

- b. Street Layout. The traditional neighborhood development should maintain the existing street grid, where present, and restore any disrupted street grid where feasible. In addition:
 - i. Intersections shall be at right angles whenever possible, but in no case less than 75 degrees. Low volume streets may form three-way intersections creating an inherent right-of-way assignment (the through street receives precedence) which significantly reduces accidents without the use of traffic controls.
 - ii. Corner radii. The roadway edge at street intersections shall be rounded by a tangential arc with a maximum radius of [15 feet] for local streets and [20 feet] for intersections involving collector or arterial streets. The intersection of a local street and an access lane or alley shall be rounded by a tangential arc with a maximum radius of 10 feet.

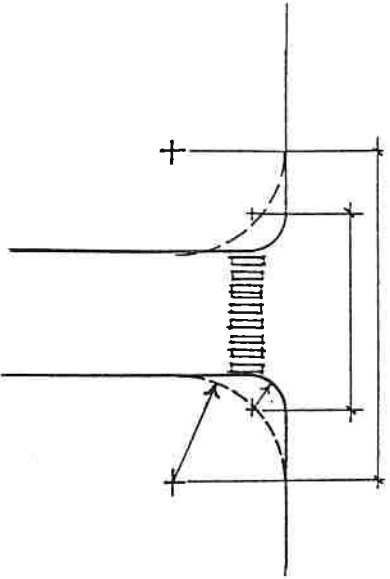

Figure 8. Plan-view diagram of a street intersection. Reducing the radius of street corners slows turning vehicle traffic and shortens pedestrian crosswalks.

❖ A Model Ordinance for a Traditional Neighborhood Development ❖

iii. Curb cuts for driveways to individual residential lots shall be prohibited along arterial streets. Curb cuts shall be limited to intersections with other streets or access drives to parking areas for commercial, civic or multifamily residential uses. Clear sight triangles shall be maintained at intersections, as specified below, unless controlled by traffic signal devices:

intersection of: minimum clear sight distance:

local street and collector	[120 feet]
collector and collector	[130 feet]
collector and arterial	[50 feet]

iv. The orientation of streets should enhance the visual impact of common open spaces and prominent buildings, create lots that facilitate passive solar design, and minimize street gradients. All streets shall terminate at other streets or at public land, except local streets may terminate in stub streets when such streets act as connections to future phases of the development. Local streets may terminate other than at other streets or public land when there is a connection to the pedestrian and bicycle path network at the terminus.

c. Parking requirements. Parking areas for shared or community use should be encouraged. In addition:

- i. In the mixed use area, any parking lot shall be located at the rear or side of a building. If located at the side, screening shall be provided as specified in section 4.8.
- ii. A parking lot or garage may not be adjacent to or opposite a street intersection.
- iii. In the mixed use area, a commercial use must provide one parking space for every [500] square feet of gross building area.

❖ A Model Ordinance for a Traditional Neighborhood Development ❖

Ordinance Language

Commentary

- iv. Parking lots or garages must provide not less than one bicycle parking space for every [10] motor vehicle parking spaces.
- v. Adjacent on-street parking may apply toward the minimum parking requirements.
- vi. In the mixed residential areas, parking may be provided on-site. [One] off-street parking space with unrestricted ingress and egress shall be provided for each secondary dwelling unit.
- vii. Multi-family uses must provide one parking space for every dwelling unit and [0.5] parking space for each additional bedroom.

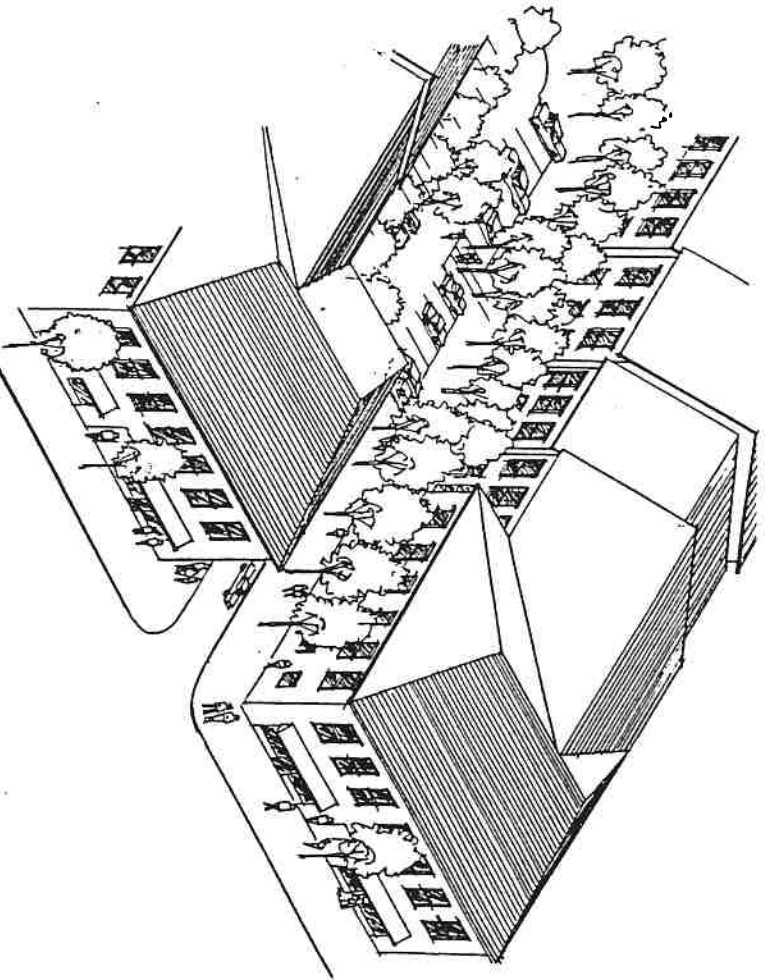

Figure 9. Aerial perspective sketch of a mixed-use area integrating commercial (ground floor) and residential (second story) uses. A relatively narrow gap in the continuous "street wall" (created by the mixed-use buildings) provides access from the street to a landscaped and "pedestrian-friendly" parking lot.

- d. Service access. Access for service vehicles should provide a direct route to service and loading dock areas, while avoiding movement through parking areas.
- e. Paving. Reduction of impervious surfaces through the use of interlocking pavers is strongly encouraged for areas such as remote parking lots and parking areas for periodic uses.

4.7 Architectural Standards. A variety of architectural features and building materials is encouraged to give each building or group of buildings a distinct character.

1. Guidelines for Existing Structures

- a. Existing structures, if determined to be historic or architecturally significant, shall be protected from demolition or encroachment by incompatible structures or landscape development.
- b. The U.S. Secretary of the Interior's Standards for Rehabilitation of Historic Properties shall be used as the criteria for renovating historic or architecturally significant structures.

2. Guidelines for New Structures

- a. Height. New structures within a Traditional Neighborhood Development shall be no more than [3 stories] for single-family residential, or [5 stories] for commercial, multi-family residential, or mixed use.

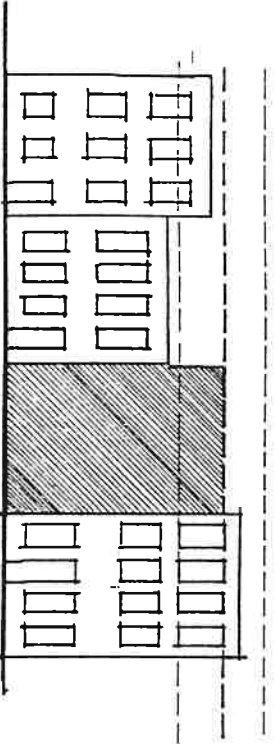

Figure 10. Schematic elevation sketch of a mixed-use "streetscape." To create a visually unified "streetwall," buildings should be no more than 30% taller or 30% shorter than the average building height on the block.

A goal of traditional neighborhood development is that it is compact. Compact development in part means the development is designed for the human scale. This emphasis on design includes being sensitive to walking distances, the height of buildings, the design of street lights and signs, sidewalks, and other features.

Guidelines for new structures within a Traditional Neighborhood Development must be responsive to the community context. It may be appropriate to conduct an architectural inventory of existing architectural styles in the community and determine which, if any, styles should be replicated.

❖ A Model Ordinance for a Traditional Neighborhood Development ❖

Ordinance Language

Commentary

- b. Entries and Facades
- i. The architectural features, materials, and the articulation of a facade of a building shall be continued on all sides visible from a public street.
 - ii. The front facade of the principal building on any lot in a Traditional Neighborhood Development shall face onto a public street.
 - iii. The front facade shall not be oriented to face directly toward a parking lot.
 - iv. Porches, pent roofs, roof overhangs, hooded front doors or other similar architectural elements shall define the front entrance to all residences.
 - v. For commercial buildings, a minimum of 50 percent of the front facade on the ground floor shall be transparent, consisting of window or door openings allowing views into and out of the interior.
 - vi. New structures on opposite sides of the same street should follow similar design guidelines. This provision shall not apply to buildings bordering civic uses.

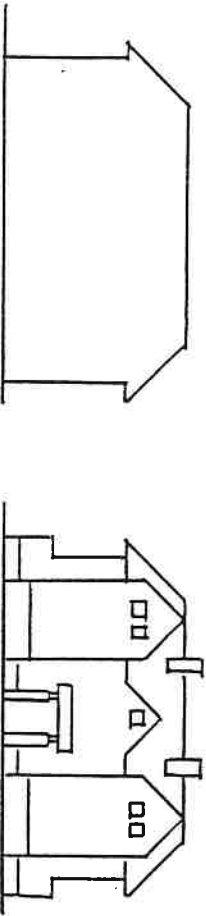

Figure 11. Schematic elevation sketches of two multi-storied buildings with equal heights and widths. Architectural details such as porches, windows, and roof dormers “articulate” a building’s facade (right) which enhances visual quality and contributes to a human-scaled development.

3. **Guidelines for garages and secondary dwelling units.** Garages and secondary dwelling units may be placed on a single-family detached residential lot within the principal building or an accessory building provided that the secondary dwelling unit shall not exceed [800] square feet.

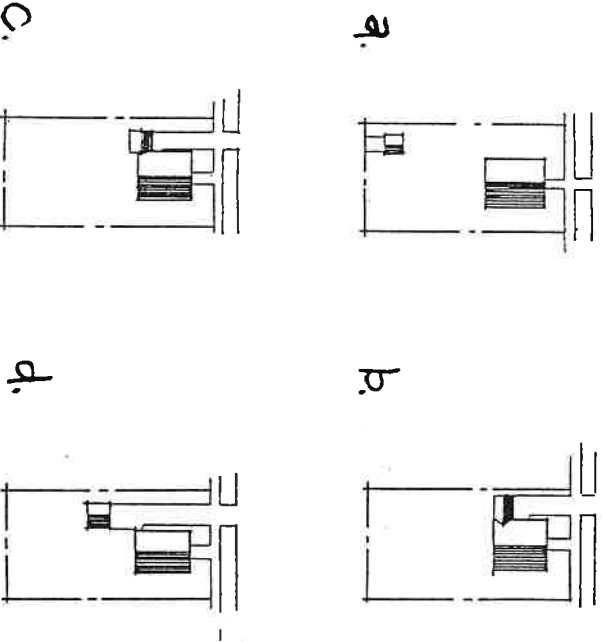

Figure 12. Plan-view diagrams of four alternative garage locations on a single-family housing lot: a) detached garage is accessed from an alley, b and c) attached garage is accessed from the local street, d) detached garage, behind the house, is accessed from the local street.

4. **Guidelines for exterior signage.** A comprehensive sign program is required for the entire Traditional Neighborhood Development which establishes a uniform sign theme. Signs shall share a common style (e.g., size, shape, material). In the mixed use area, all signs shall be wall signs or cantilever signs. Cantilever signs shall be mounted perpendicular to the building face and shall not exceed [8] square feet.

These regulations are not meant to supersede an existing ordinance for exterior signage. If such an ordinance already exists in a community, it should be used.

5. **Guidelines for lighting.**

- a. Street lighting shall be provided along all streets. Generally more, smaller lights, as opposed to fewer, high-intensity lights, should be used. Street lights shall be installed on both sides of the street at intervals of no greater than [75] feet. Street lighting design shall meet the minimum standards developed by the Illumination Engineering Society.
- b. Exterior lighting shall be directed downward in order to reduce glare onto adjacent properties.

4.8

Landscaping and Screening Standards. Overall composition and location of landscaping shall complement the scale of the development and its surroundings. In general, larger, well-placed contiguous planting areas shall be preferred to smaller, disconnected areas. Where screening is required by this ordinance, it shall be at least 3 feet in height, unless otherwise specified. Required screening shall be at least 50 percent opaque throughout the year. Required screening shall be satisfied by one or some combination of: a decorative fence not less than 50 percent opaque behind a continuous landscaped area, a masonry wall, or a hedge.

1. Street trees. A minimum of one deciduous canopy tree per [30 - 35] feet of street frontage, or fraction thereof, shall be required. Trees can be clustered and do not need to be evenly spaced. Trees should preferably be located between the sidewalk and the curb, within the landscaped area of a boulevard, or in tree wells installed in pavement or concrete. If placement of street trees within the right-of-way will interfere with utility lines, trees may be planted within the front yard setback adjacent to the sidewalk.
2. Parking area landscaping and screening.
 - a. All parking and loading areas fronting public streets or sidewalks, and all parking and loading areas abutting residential districts or uses, shall provide:
 - i. A landscaped area at least [5] feet wide along the public street or

❖ A Model Ordinance for a Traditional Neighborhood Development ❖

Ordinance Language

Commentary

- ii. Screening at least [3] feet in height and not less than [50] percent opaque.
 - iii. One tree for each [25] linear feet of parking lot frontage.
 - b. Parking area interior landscaping. The corners of parking lots, “islands,” and all other areas not used for parking or vehicular circulation shall be landscaped. Vegetation can include turf grass, native grasses or other perennial flowering plants, vines, shrubs or trees. Such spaces may include architectural features such as benches, kiosks or bicycle parking.
 - c. In large parking lots containing more than [200] spaces, an additional landscaped area of at least [300] square feet shall be provided for each [25] spaces or fraction thereof, containing one canopy tree. The remainder shall be covered with turf grass, native grasses or other perennial flowering plants, vines or shrubs.
 3. Installation and Maintenance of Landscaping Materials.
 - a. All landscape materials shall be installed to current industry standards.
 - b. Maintenance and replacement of landscape materials shall be the responsibility of the property owner. Landscape maintenance should incorporate environmentally sound management practices, including the use of water- and energy-efficient irrigation systems such as drip irrigation, and pruning primarily for plant health, replacing dead materials annually.
 4. Materials. All plant materials must meet the minimum standards set by the American Association of Nurserymen. Landscape species shall be indigenous or proven adaptable to the climate, but shall not be invasive species. Plant materials shall comply with the following standards:
 - a. Minimum plant size shall be as specified as follows (for the purpose of determining tree trunk size, the diameter shall be measured 6 inches above ground level):

Cities and villages need to make this section consistent with and existing landscaping ordinances. Many ordinances include a list of recommended or required plant materials that have been determined to be suitable. Such a list would be specific to each community and its climate zone and site conditions. Use of native plant species is one element of

❖ A Model Ordinance for a Traditional Neighborhood Development ❖

Ordinance Language

Commentary

Plant Type	Minimum Size
Evergreen tree	6 feet in height
Deciduous canopy tree	2 1/2 inches caliper at dbh*
Small deciduous tree	1 1/2 inches caliper at dbh*
Evergreen or deciduous shrubs	18 - 24 inches in height

sustainable design, since native species tend to be tolerant of weather conditions, less water-consumptive, and compatible with existing vegetation (as opposed to exotic species that may prove invasive).

* dbh = diameter at breast height

- b. Landscape materials shall be tolerant of specific site conditions, including but not limited to heat, drought and salt.
- c. Existing healthy plant material may be utilized to satisfy landscaping requirements, provided it meets the minimum plant size specified above.
- d. Landscape materials that are used for screening shall be of a size that allows growth to the desired height and opacity within 2 years.