



Z315
VANDAL PROOF ACCESS DRAIN

SPECIFICATION SHEET

TAG _____

Dimensional Data (inches and [mm]) are Subject to Manufacturing Tolerances and Change Without Notice

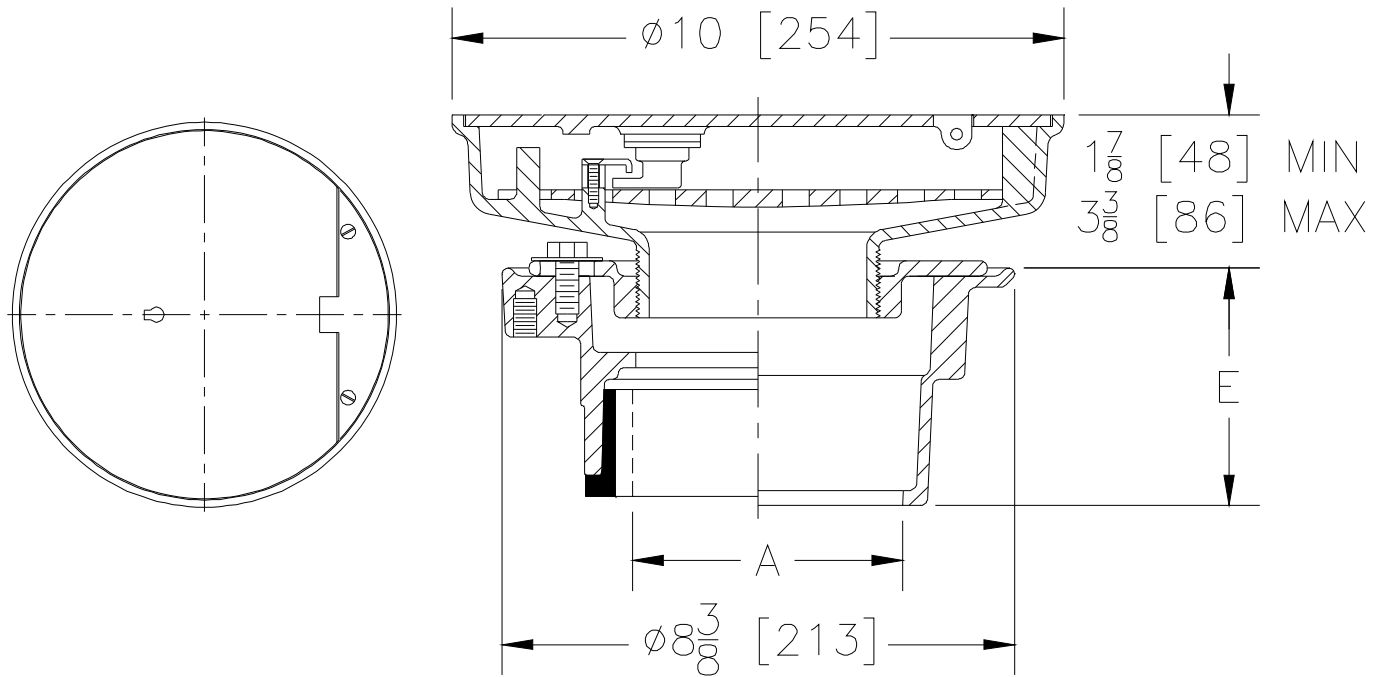

A-Pipe Size In [mm]	Approx. Wt. Lbs. [kg]
2 [51]	23 [10]
3 [76]	24 [11]
4 [102]	25 [11]

ENGINEERING SPECIFICATION: ZURNZN315

10" [254mm] Top vandal proof drain, Dura-Coated cast iron body bottom outlet, invertible membrane clamp, vertically adjustable nickel bronze top with secondary strainer and hinged solid locking cover.

OPTIONS (Check/specify appropriate options)

PIPE SIZE

2,3,4 [51,76,102]

2,3,4 [51,76,102]

(Specify size/type) **OUTLET**

____ NH No-Hub

____ NL Neo-Loc

'E' BODY HT. DIM.

3-7/8 [98]

3-3/4 [95]

PREFIXES

____ ZN D.C.C.I. Body w/Polished Nickel Bronze Top*

SUFFIXES

____ -G Galvanized Cast Iron

____ -HL Hinged Locking Grate

____ -P Trap Primer Connection

____ -TC Neo-Loc Test Cap Gasket

(2,3,4 [51,76,102] NL Bottom Outlet Only)

* Regularly furnished unless otherwise specified.