

Project location:			
Project name:			
Model code #:		Date	

**DESCRIPTION:**

Circular light fixture in cast and sheet aluminium with suspended connection. Tilting bottom frame for access to auxiliary and optic compartment. Electrical components on removable plate. Optic system asymmetric with refractive lens in polycarbonate UV resistant, screen in frosted acrylic moulded in a single piece. Light source with LED module (power led's), combined to a internal large heat sink in aluminium for optimal control of temperature and self regulating power rated for a operative life of over 80,000 hours (15 years). The Light 600, require low-maintenance thank to Leds sources and IP66 protection rating in optic compartment, and is ideally for illuminating urban area, cycle paths or pedestrian walkways, parks and gardens. The suggested height of installation from 11.5' to 16.5'.

**LIGHT 600**

**LED Source - Comfort range - Heritage**  
**Voltage = 120-277,50/60 Hz**

EPA = 1.41 ft²  
 Weight = 28.66 lb (13 Kg)  
 Height = 3' - 1 5/6"  
 Diameter = 1' - 6 1/2"

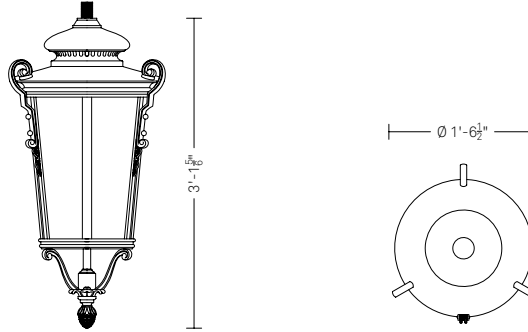

Compliance:  
 UL Standard 1598 CSA C22.2 no.250.0-8

**MODEL:**  
 code sample: **SU600L021P202**

Mounting	Series	Optic system	CCT	Lumen output	Driver function
SU = Suspended	600L = Series 600	02 = type III Very Short 06 = type V Short	1 = 3,000K 3 = 4,000K	P2 = 2,500 lm P4 = 3,500 lm P6 = 4,500 lm	02 = 1-10V + NCL 06 = DALI + NCL 14 = 6 hours. aut. flux red. + NCL 71 = Manual Dimming

**SPECIFICATIONS:**

Construction:

- Upper tilting frame in cast aluminium.
- Tilting lower frame composed of two rings, three uprights and a three-armed bracket with flange.
- Suitable for wet location (IP 43).

Materials:

- Cast aluminium (ASTM B179-82)
- Sheet aluminium
- Hot galvanized steel
- Screen in frosted acrylic in a single piece (shock resistance IK06)
- Brass and stainless steel screws

Finish:

- Standard colour is dark grey NERI type.
- Information about paint steps used on this product in specific technical sheet.

Fastening:

- Suspended installation with threaded tube (G 3/4" - UNI 338; ISO 228/1).

Operation and maintenance:

- Follow the instructions for operation and maintenance.
- No maintenance is required, except a periodic cleaning of the screen from dust.

**TECHNICAL DATA:**

Electrical:

- Voltage: 120-277V (universal)
- Rated power: from 26W to 53W
- Frequency: 50/60Hz.
- Protection rating: IP43
- Operating temp.: -22F°+104F°(-30°C +40°C).
- Electronic ballast with self-diagnostic functions and monitoring of over temperatures.
- Estimate life :B10 at 80.000 hours.

Optical Features:

- Light source: power leds.
- Lumen output: from 2.500 to 4.500 lm
- Colour temperature: 3.000K or 4.000K
- Chromatic Rendering Index: CRI>70.
- Estimated life: 80.000 hours (L85 - Ta 25°C).
- Protection rating: IP66 (Optic).
- Heat sink in aluminium extruded for a optimal control of temperature with electronic sensor on LED plate for the control of over temperatures.
- Refractive lens in PC (UV resistant).
- IES classification: cat off.
- Shock resistance of screen: IK10

On demand features

- Painting: colour of RAL range.
- Information about paint steps used on this product in specific technical sheet.

**CONFIGURATION TABLES:**

Configuration tables of luminous fluxes.

The efficacy (lm/W) on table refers to the complete system.

3,000 K - Colour temperature			
Code	lm output	Watt	lm/W
1P2	2,500	27	79
1P4	3,500	39	76
1P6	4,500	53	72

4,000 K - Colour temperature			
Code	lm output	Watt	lm/W
3P2	2,500	26	82
3P4	3,500	36	82
3P6	4,500	48	80

Configuration of driver functions

Code	Driver function
02	1-10V control + constant flux control (1-10V + NCL)
06	DALI control + constant flux control (DALI + NCL)
14	6 hours aut. flux reduction -30% + constant flux control (6H NVL + NCL)
71	Optional: Internal manual dimming control allowing up to 50% light reduction. Setup by qualified operator and with powerline disconnected.

Note:

- NCL: constant flux control is standard with all driver functions.

Project location:			
Project name:			
Model code #:		Date	

## LIGHT 600

LED Source - Comfort range  
Heritage

### PHOTOMETRIC VALUE

LM-79 test and reports are performed in accordance with IESNA standards.

OPTIC 02 - Type III short Cutoff

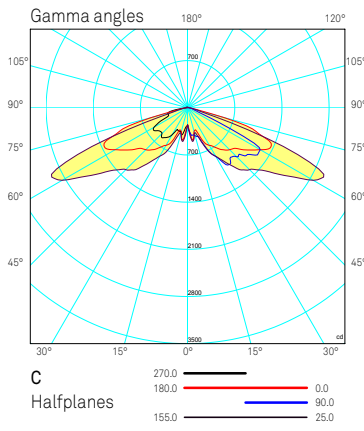

OPTIC 06 - Type V short Cutoff

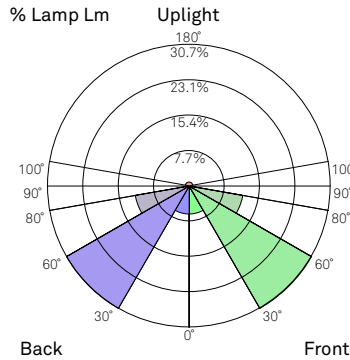
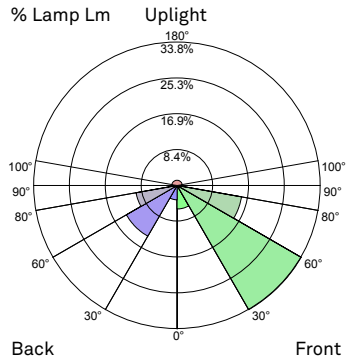
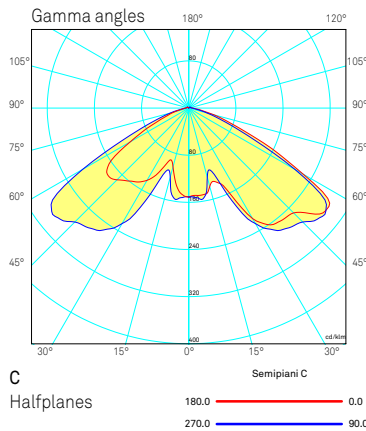

Luminaire Classification System (LCS)			
LCS Zone	Angles	% Lamp	% Lum
FL	0° - 30°	5.5%	6.5%
FM	30° - 60°	33.8%	39.8%
FH	60° - 80°	15.4%	18.2%
FVH	80° - 90°	0.6%	0.7%
BL	0° - 30°	3.4%	4.0%
BM	30° - 60°	13.8%	16.3%
BH	60° - 80°	9.8%	11.6%
BVH	80° - 90°	0.8%	0.9%
UL	90° - 100°	0.5%	0.6%
UH	100° - 180°	1.2%	1.5%
Totals		84.8%	100%
P2 - BUG: B1 U2 G1			
P4 - BUG: B1 U2 G1			
P6 - BUG: B1 U3 G1			

Luminaire Classification System (LCS)			
LCS Zone	Angles	% Lamp	% Lum
FL	0° - 30°	6.1%	6.1%
FM	30° - 60°	30.7%	30.7%
FH	60° - 80°	11.9%	11.9%
FVH	80° - 90°	0.6%	0.6%
BL	0° - 30°	6.1%	6.1%
BM	30° - 60°	30.7%	30.7%
BH	60° - 80°	11.9%	11.9%
BVH	80° - 90°	0.6%	0.6%
UL	90° - 100°	0.5%	0.5%
UH	100° - 180°	0.8%	0.8%
Totals		100.0%	100.0%
P2 - BUG: B1 U2 G1			
P4 - BUG: B1 U2 G1			
P6 - BUG: B2 U2 G1			

### Compliance

CE certificated post, compliant with standard UNI EN 40-5. 

### Description

Lamp post in UNI EN 1561 cast iron and UNI EN 10219-1 steel, hot-galvanized UNI EN ISO 1461 standards and corresponding in shape, size and ornamentation to the diagrams, which are an integral part of the specifications.

Tapered post (A) in steel with a circular cross-section, hot-galvanized, suitable for flange fixing (diam. 266 mm - thickness 18 mm) on a foundation plinth (P).

The post is made up of two tubes welded together at their junctions (B), with dimensions  $\varnothing 127 \times 3500 \text{ mm} - \varnothing 102 \times 1900 \text{ mm}$ . It is provided with an M10 earthing bolt marked by a small indicator plate, a slot (C - height 186 x 45 mm) for the installation of a Class II insulation terminal board with or without fuse (Conchiglia). The top of the post has six M10 screws (Z) for securing a suspension bracket fitted into the post.

1°) Base element height 1540 mm, with a square plinth (600 x 600 x 210 mm) with cut-off corners, a square section with cut-off corners (380 x 380 x 130 mm) surmounted by a decorative band of twenty-eight ovoli and leaf designs (D), a central section (E) with a square cross-section with cut-off corners (240 x 240 x 660 mm) and an inspection hatch (90 x 360 mm). At the top is a square cymatium (F) with cut-off corners (360 x 360 mm) that supports a tapered section (G) decorated with acanthus leaves in high relief, forming a junction for the cylindrical post (A).

The base is cast as a single piece.

2°- 3°) Cast iron decorative junctions to be fitted at the points where the post narrows (B). Shape and size are as shown in the diagram.

The total height up to the third junction is 5400 mm.

Total weight is 241 Kg.

### Protection of surfaces

Please refer to the specification on painting procedures of the materials.

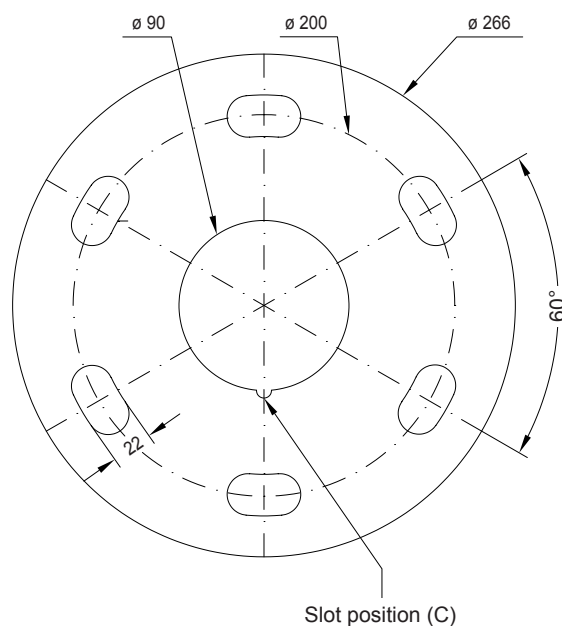

Flange plan  
Scale 1:4

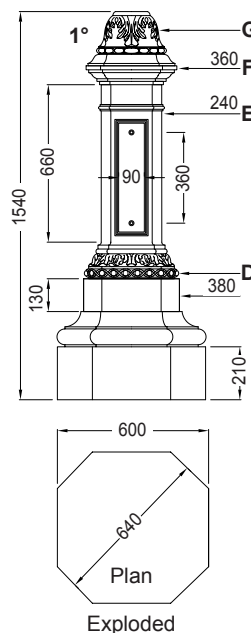

Exploded

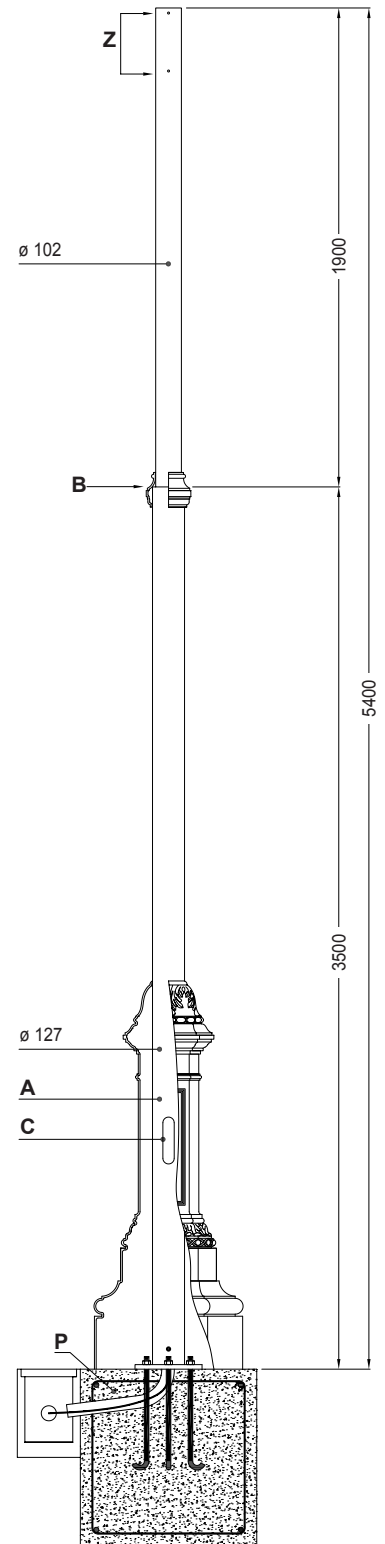

Section

NB: The measurements are in millimeters.

Neri S.p.A. Property - Any reproduction and use for its own purposes is forbidden.

## Use

Suitable support for suspended light fixtures.

## Materials

Made in UNI EN 1561 cast iron, UNI EN 1563 nodular cast iron and S235J UNI EN 10219-1 steel, hot dip galvanized according to UNI EN ISO 1461.

Screws in stainless steel.

## Description

The top section is made up of the following elements:

- 1°) A hot-galvanized steel tube height 226.5 cm (Ø 6.0 cm) for the coupling on the posts with 10.2 cm of diameter; it is provided of a flange (A - Ø 7.5 cm) and holes (Ø 2.0 cm) for the passage of power supply cable (F).
- 2°) Cast iron junction cast in a single piece, height 115 mm.
- 3°) A ring in hot-galvanized steel for lower support of the suspension brackets. It is secured to the supporting tube (1°) with two M8 grubs.
- 4°) A ring in hot-galvanized steel for upper support of the suspension brackets. The ring has four holes (B - Ø 1.8 cm) for the passage of power supply cable. It is secured to the supporting tube (1°) with two M8 grubs.
- 5°) A suspension bracket height 155 cm, with a protrusion of 93 cm. Structurally the bracket is composed of a tube in steel (Ø 4.2 cm), decorations in cast iron and support attachments (C) in spheroidal cast iron. The entire assembly is hot galvanized. The brackets is fixed to the support rings 3° - 4° with four M8 screws. At the end of each suspension bracket there is a connection (D) in cast iron with internal thread G3/4" for attaching the light fixture. The power cables pass inside each suspension brackets (F).
- 6°) A cast iron finial in the form of a sphere with a tall point (height 67 cm), decorated with leaves in the central section (Ø 20 cm). The finial is fitted onto element (1°) and is secured with three M8 screws (E).
- 7°) Two decorative elements in cast iron. Each element is secured with two M8 screws to support rings (3°) and (4°).

## Dimensions and weight

Height 255 cm; width 93 cm.

Weight 69 kg.

## Protection of surfaces

Please refer to the specification on painting procedures of the materials.

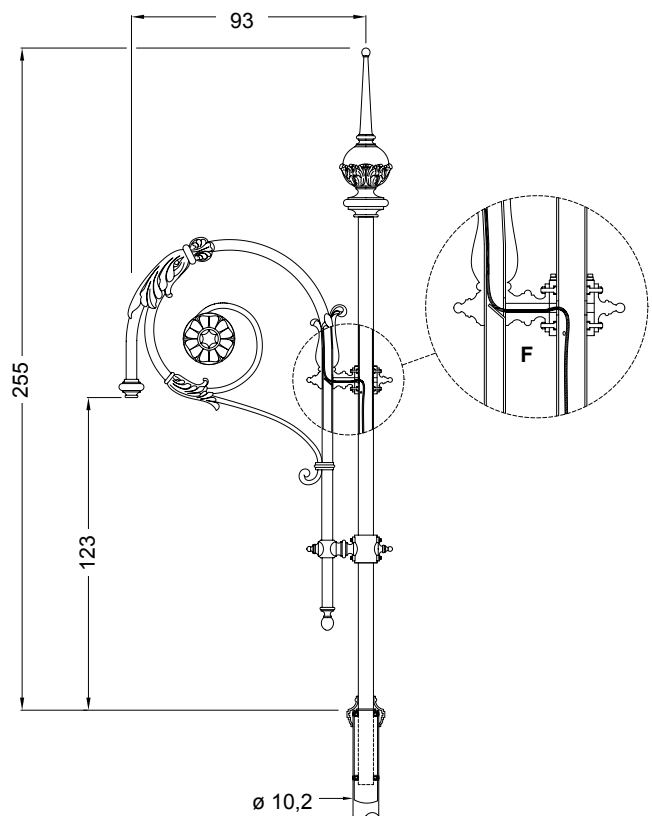
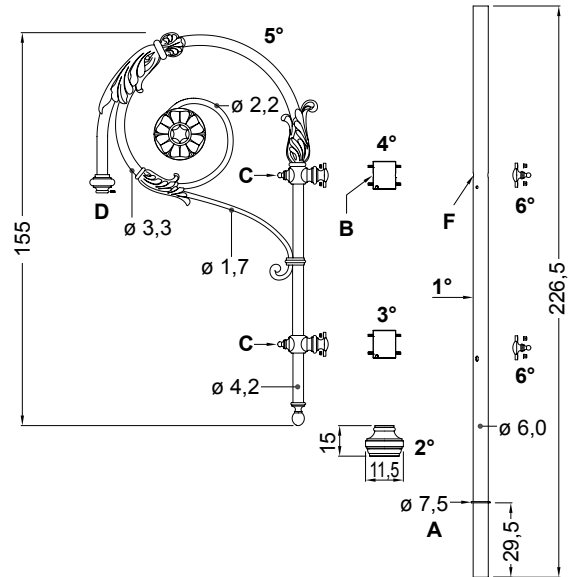
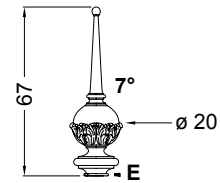

**NB:** The measurements are in millimeters.

**Neri S.p.A. Property** - Any reproduction and use for its own purposes is forbidden.

Project location:			
Project name:			
Model code #:		Date	

## DESCRIPTION:

Circular light fixture in cast and sheet aluminium with suspended connection. Tilting bottom frame for access to auxiliary and optic compartment. Electrical components on removable plate. Optic system asymmetric with refractive lens in polycarbonate UV resistant, screen in frosted acrylic moulded in a single piece. Light source with LED module (power led's), combined to a internal large heat sink in aluminium for optimal control of temperature and self regulating power rated for a operative life of over 80,000 hours (15 years). The Light 600, require low-maintenance thank to Leds sources and IP66 protection rating in optic compartment, and is ideally for illuminating urban area, cycle paths or pedestrian walkways, parks and gardens. The suggested height of installation from 11.5' to 16.5'.

## LIGHT 600

**LED Source - Comfort range - Heritage**

**Voltage = 120-277,50/60 Hz**

EPA = 1.41 ft²

Weight = 28.66 lb (13 Kg)

Height = 3' - 1 5/6"

Diameter = 1' - 6 1/2"

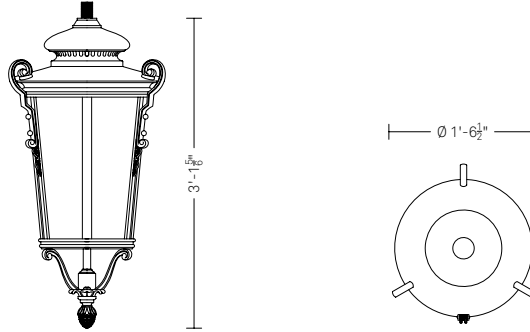

Compliance:  
UL Standard 1598 CSA C22.2 no.250.0-8

## MODEL:

code sample: **SU600L021P202**

Mounting	Series	Optic system	CCT	Lumen output	Driver function
SU = Suspended	600L = Series 600	02 = type III Very Short 06 = type V Short	1 = 3,000K 3 = 4,000K	P2 = 2,500 lm P4 = 3,500 lm P6 = 4,500 lm	02 = 1-10V + NCL 06 = DALI + NCL 14 = 6 hours. aut. flux red. + NCL 71 = Manual Dimming

## SPECIFICATIONS:

### Construction:

- Upper tilting frame in cast aluminium.
- Tilting lower frame composed of two rings, three uprights and a three-armed bracket with flange.
- Suitable for wet location (IP 43).

### Materials:

- Cast aluminium (ASTM B179-82)
- Sheet aluminium
- Hot galvanized steel
- Screen in frosted acrylic in a single piece (shock resistance IK06)
- Brass and stainless steel screws

### Finish:

- Standard colour is dark grey NERI type.
- Information about paint steps used on this product in specific technical sheet.

### Fastening:

- Suspended installation with threaded tube (G 3/4" - UNI 338; ISO 228/1).

### Operation and maintenance:

- Follow the instructions for operation and maintenance.
- No maintenance is required, except a periodic cleaning of the screen from dust.

## TECHNICAL DATA:

### Electrical:

- Voltage: 120-277V (universal)
- Rated power: from 26W to 53W
- Frequency: 50/60Hz.
- Protection rating: IP43
- Operating temp.: -22F°+104F°(-30°C +40°C).
- Electronic ballast with self-diagnostic functions and monitoring of over temperatures.
- Estimate life :B10 at 80.000 hours.

### Optical Features:

- Light source: power leds.
- Lumen output: from 2.500 to 4.500 lm
- Colour temperature: 3.000K or 4.000K
- Chromatic Rendering Index: CRI>70.
- Estimated life: 80.000 hours (L85 - Ta 25°C).
- Protection rating: IP66 (Optic).
- Heat sink in aluminium extruded for a optimal control of temperature with electronic sensor on LED plate for the control of over temperatures.
- Refractive lens in PC (UV resistant).
- IES classification: cat off.
- Shock resistance of screen: IK10

### On demand features

- Painting: colour of RAL range.
- Information about paint steps used on this product in specific technical sheet.

## CONFIGURATION TABLES:

### Configuration tables of luminous fluxes.

The efficacy (lm/W) on table refers to the complete system.

3,000 K - Colour temperature			
Code	lm output	Watt	lm/W
1P2	2,500	27	79
1P4	3,500	39	76
1P6	4,500	53	72

4,000 K - Colour temperature			
Code	lm output	Watt	lm/W
3P2	2,500	26	82
3P4	3,500	36	82
3P6	4,500	48	80

### Configuration of driver functions

Code	Driver function
02	1-10V control + constant flux control (1-10V + NCL)
06	DALI control + constant flux control (DALI + NCL)
14	6 hours aut. flux reduction -30% + constant flux control (6H NVL + NCL)
71	Optional: Internal manual dimming control allowing up to 50% light reduction. Setup by qualified operator and with powerline disconnected.

### Note:

- NCL: constant flux control is standard with all driver functions.

Project location:			
Project name:			
Model code #:		Date	

## LIGHT 600

LED Source - Comfort range  
Heritage

### PHOTOMETRIC VALUE

LM-79 test and reports are performed in accordance with IESNA standards.

OPTIC 02 - Type III short Cutoff

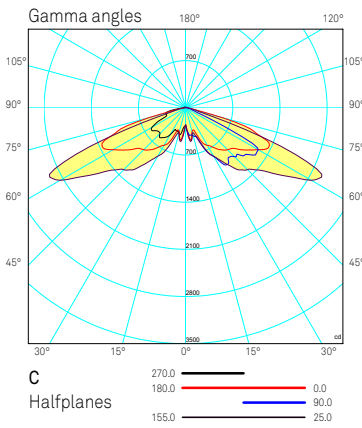

OPTIC 06 - Type V short Cutoff

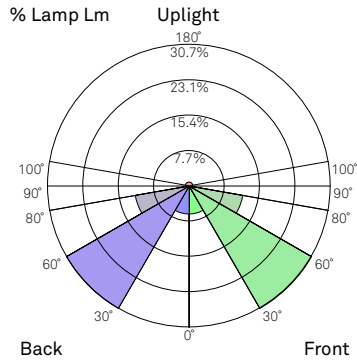
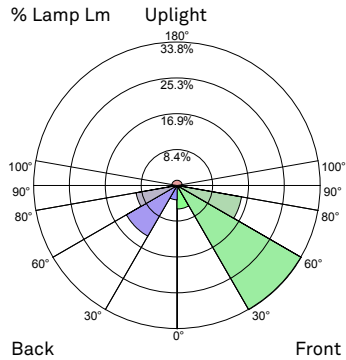
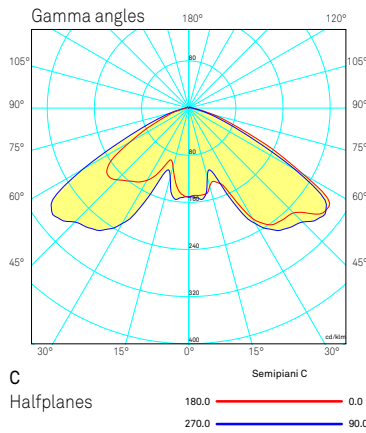

Luminaire Classification System (LCS)			
LCS Zone	Angles	% Lamp	% Lum
FL	0° - 30°	5.5%	6.5%
FM	30° - 60°	33.8%	39.8%
FH	60° - 80°	15.4%	18.2%
FVH	80° - 90°	0.6%	0.7%
BL	0° - 30°	3.4%	4.0%
BM	30° - 60°	13.8%	16.3%
BH	60° - 80°	9.8%	11.6%
BVH	80° - 90°	0.8%	0.9%
UL	90° - 100°	0.5%	0.6%
UH	100° - 180°	1.2%	1.5%
Totals		84.8%	100%
P2 - BUG: B1 U2 G1			
P4 - BUG: B1 U2 G1			
P6 - BUG: B1 U3 G1			

Luminaire Classification System (LCS)			
LCS Zone	Angles	% Lamp	% Lum
FL	0° - 30°	6.1%	6.1%
FM	30° - 60°	30.7%	30.7%
FH	60° - 80°	11.9%	11.9%
FVH	80° - 90°	0.6%	0.6%
BL	0° - 30°	6.1%	6.1%
BM	30° - 60°	30.7%	30.7%
BH	60° - 80°	11.9%	11.9%
BVH	80° - 90°	0.6%	0.6%
UL	90° - 100°	0.5%	0.5%
UH	100° - 180°	0.8%	0.8%
Totals		100.0%	100.0%
P2 - BUG: B1 U2 G1			
P4 - BUG: B1 U2 G1			
P6 - BUG: B2 U2 G1			

## Use

Suitable support for suspended light fixtures.

## Materials

Made in UNI EN 1561 cast iron, UNI EN 1563 nodular cast iron and S235J UNI EN 10219-1 steel, hot dip galvanized according to UNI EN ISO 1461.

Screws in stainless steel.

## Description

The top section is made up of the following elements:

- 1°) A hot-galvanized steel tube height 226.5 cm (Ø 6.0 cm) for the coupling on the posts with 10.2 cm of diameter; it is provided of a flange (A - Ø 7.5 cm) and holes (Ø 2.0 cm) for the passage of power supply cable (F).
- 2°) Cast iron junction cast in a single piece, height 115 mm.
- 3°) A ring in hot-galvanized steel for lower support of the suspension brackets. It is secured to the supporting tube (1°) with two M8 grubs.
- 4°) A ring in hot-galvanized steel for upper support of the suspension brackets. The ring has four holes (B - Ø 1.8 cm) for the passage of power supply cable. It is secured to the supporting tube (1°) with two M8 grubs.
- 5°) A suspension bracket height 155 cm, with a protrusion of 93 cm. Structurally the bracket is composed of a tube in steel (Ø 4.2 cm), decorations in cast iron and support attachments (C) in spheroidal cast iron. The entire assembly is hot galvanized. The brackets is fixed to the support rings 3° - 4° with four M8 screws. At the end of each suspension bracket there is a connection (D) in cast iron with internal thread G3/4" for attaching the light fixture. The power cables pass inside each suspension brackets (F).
- 6°) A cast iron finial in the form of a sphere with a tall point (height 67 cm), decorated with leaves in the central section (Ø 20 cm). The finial is fitted onto element (1°) and is secured with three M8 screws (E).
- 7°) Two decorative elements in cast iron. Each element is secured with two M8 screws to support rings (3°) and (4°).

## Dimensions and weight

Height 255 cm; width 93 cm.

Weight 69 kg.

## Protection of surfaces

Please refer to the specification on painting procedures of the materials.

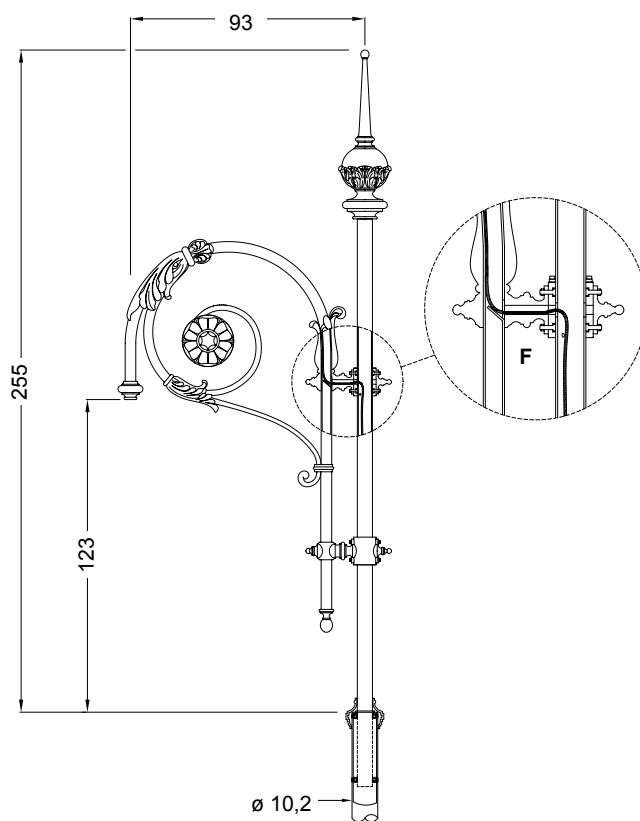
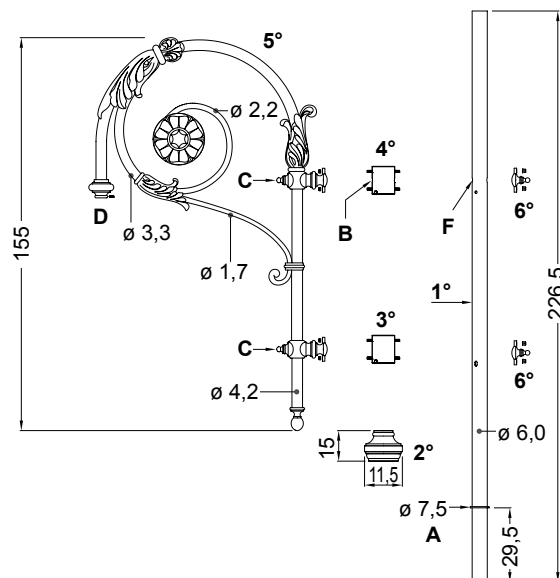
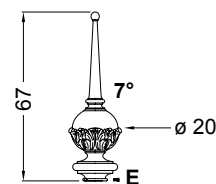

**NB:** The measurements are in millimeters.

**Neri S.p.A. Property** - Any reproduction and use for its own purposes is forbidden.